

MONITORING AND CONTROL OF PROCESS AND POWER SYSTEMS : TOWARDS NEW PARADIGMS

Status report prepared by the IFAC Coordinating
committee on Process and Power Systems

Denis Dochain ^{*,1} Wolfgang Marquardt ^{**}
Sang Chul Won ^{***} Om Malik ^{****} Michel Kinnaert [†]

^{*} *CESAME, Université Catholique de Louvain
4-6 avenue G. Lemaître, 1348 Louvain-la-Neuve, Belgium
e-mail : dochain@csam.ucl.ac.be, fax : 32-10-472180*

^{**} *RWTH Aachen, Lehrstuhl fr Prozesstechnik
Templergraben 55, 52056 Aachen, Germany*

^{***} *Dept Electr. Eng., Pohang Univ. of Science of Technol.
San 31 Hyojadong Namku, Pohang 790-784, Korea*

^{****} *ECE Dept. University of Calgary
Calgary, AB. T2N 1N4 Canada*

[†] *Control Engineering Department, ULB
CP 165/55, 50 av. F.D. Roosevelt, 1050 Brussels, Belgium*

Abstract: Process and power plant control, along with fault detection/isolation are being addressed by significant on-going research with many theoretical developments focused on improvements for all of these major industrial applications. This report provides an overview of the current key problems, recent accomplishments and trends, as well as a forecast of anticipated developments within this very important field of industrial applications. *Copyright © 2005 IFAC*

Keywords: Process systems, power systems, fault detection and isolation

1. INTRODUCTION

Most major industrial systems in today's economy use automation and control systems technology. These industrial systems focus on many diverse and very important fields including many process control industries, of which Chemical Processing is a major example. Likewise, Power Plants and Power Systems as well as Mining, Mineral, and Metal processing are similarly important throughout the entire industrial world. A critically important support technology which impacts virtually

all control-related industry is Fault Detection and Isolation.

Process and power plant control, along with fault detection/isolation are being addressed by significant on-going research with many theoretical developments focused on improvements for all of these major industrial applications. This report provides an overview of the current key problems, recent accomplishments and trends, as well as a forecast of anticipated developments within this very important field of industrial applications.

¹ Partially supported by the Roman Senate

2. CURRENT KEY PROBLEMS

Most of the key problems in chemical, mining, mineral, metal, power generation/distribution, and other processing industries stem from the paradigm shift that can be observed throughout the power and process industries. Two areas have to be roughly distinguished in the context of the process industries : (1) manufacturing of well-established bulk chemical products and (2) development and production of specialties as well as particulate and functional products. Specific key problems can also be identified for power plants and power systems related to restructuring due to de-regulation and development of distributed generation from renewable, and in the field of Fault Detection and Isolation (FDI).

2.1 Bulk Chemical Manufacturing

The production of well-established bulk chemical products faces increasing economical pressure due to saturating markets, maturing technologies, and a steadily growing number of potential suppliers in the developing countries who are offering high quality products at competitive prices. Production can only be successful economically if the processes are driven to their true potential in order to reduce the production cost and at the same time achieve a maximum of flexibility. High performance multivariable control is a key to drive the processes closer to their constraints in order to achieve the desired high profits. Any reduction of the variance in the control loop will ultimately allow operators to move the process closer to quality, equipment or safety constraints. Variance reduction directly translates into improved economics because in most cases, economically operating points are typically located on one or more of the process constraints. The technology for the design and realization of high performance model-based constrained control systems, e.g. typically linear model-predictive controllers, for large-scale continuous plants with a large number of manipulated and controlled variables at reasonable engineering effort is one of the key challenges faced by industrial practice. The embedding of such controllers in the automation hierarchy as well as the monitoring and continuous improvement of such controllers remains a major challenge. In this context, model-based supervisory control systems that bridge the gap between the human operator and the automation system to guarantee economical and safe operation even in abnormal situations are of significant interest.

Model-based control of large-scale continuous plants has to evolve from set-point following and disturbance rejection to any-time economically optimal despite the highly dynamic environment

determined by the supply chain. Obviously, the duration of close to stationary steady-state plant operation is going to be reduced. Numerous transient phases, for example due to grade or load changes, are more and more required to achieve the required agility of the plant to meet demands of flexible just-in-time production. Typical examples are refineries, bulk petrochemical and bulk polymer plants. Linear control technology often is not sufficient to achieve the objectives of agile plant operation. Hence, model-based control and operation support systems based on rigorous nonlinear and large-scale physico-chemical process models are more appropriate in these situations. This shift in control technology results in a number of well-known challenges including development and maintenance of rigorous process models of sufficient closed-loop predictive capabilities, nonlinear model reduction technologies, nonlinear estimation and reconciliation techniques, nonlinear optimal control algorithms, and highly efficient numerical methods for the solution of large-scale nonlinear dynamic optimization problems to name only the most important. Ultimately, discrete decisions have to be taken by the control system together with the determination of the control profiles which are continuous in time. These discrete degrees of freedom stem on the one hand from the control logic, for example superimposed by the supervisory control system, and on the other hand from the purely discrete decisions which characterize plant operation. The scheduling of campaigns for the production of various process grades is a typical example of this kind. Consequently, more systematic methods for hybrid (discrete-continuous) nonlinear control as well as improved numerical algorithms for the solution of mixed-integer dynamic optimization problems are required.

2.2 Specialty chemicals manufacturing

The manufacturing of specialty chemicals, particulate or even functional materials requires related but different technologies. Time to market as well as the low volume often suggests batch rather than continuous production processes. The effort and time which can be spent for modelling is limited, uncertainty in first principles models is inevitable and has to be accounted for in a systematic way during the development of model-based solutions. Ideally, the control technology should be refined from very simple control schemes to more sophisticated model-based solutions in parallel to the process development from bench to production scale. An appropriate integration of process and control systems development should account for the accumulation of process knowledge and systematically transfer this knowledge not only into

the improvement of the product and the manufacturing plant but also into the improvement of the control and operations support systems. Ideally, the process and its control and operations support system should mature simultaneously, driven by the continuously evolving process understanding.

The control technologies required for batch processes have a lot in common with those for continuous processes operated in a large envelope of operating conditions. Nonlinearities and transient operations are key characteristics which have to drive the development of control technology and operation support system.

Because of the high added value and complexity of these products, quality control is often more important and also more difficult to achieve for speciality, particulate or functional products. This is due to the fact that the direct measurement of quality relevant process quantities is even more difficult than in the manufacturing of bulk chemicals. Sophisticated measurement techniques stemming from analytical chemistry have to continue to move into the process environment. Obviously, appropriate algorithms calibration and estimation algorithms have to be added to get valid information of the state of the process materials.

2.3 Mining, Mineral and Metal (MMM) processing

There have been various efforts for controlling processes and modeling the MMM operations. However, it is necessary to develop more optimized techniques of managing the information gathered or required from these systems which could reuse to look for continuous improvement to better tuning these systems, collaboration between departments (operations, productions, quality), maintaining the process equipment and systems, business calculations in real time and managing a complex metallurgical site. The steel industry is now facing with drastic environmental changes. While enjoying an rapidly increasing demand, steel companies have to maximize the productivity of existing facilities to cope with massive orders from customers.

2.4 Power Plants and Power Systems

Power plants and power systems (PP&PS) are generally considered to be mature technologies. However, recent major structural changes have created significant challenges from the control point of view. These structural changes are a result of two developments: (i) restructuring due to de-regulation, and (ii) development of distributed generation from renewable resources in response to environmental concerns. Both of these have

emerged in parallel, over the past less than fifteen years. They present new but different challenges as they use different technologies, their operational philosophies are different and they invariably operate at different voltage levels.

In the case of the deregulated electricity market, control at the system level will become much more important in the future as generating companies may have clients dispersed over a geographically diverse area. They produce electricity using the standard central station type of facilities and the energy is transported at the high voltage transmission level. This may require development of new centralized control strategies to avoid bottlenecks due to congestion in the event of a lack of transmission capacity. To maintain successful and reliable system operation, it offers additional challenge of the co-ordination of controls between the various independent bodies, each having different objectives and goals. Distributed generation using renewable resources is connected to the system at lower voltage levels. It requires development of a whole new set of local/distributed control strategies because of the different operational characteristics than the common large hydro and fossil fuel generating plants. Wind power and solar cells may be considered as intermittent sources. Development of suitable controls to integrate such sources with the conventional power systems and the safety aspects of connecting the distributed generation to the interconnected large system still require considerable attention.

The recent incidents of a number of major black-outs in various parts of North America (see <http://pserc.org> for a website with the report on the August 2004 blackout in USA and Canada) and Europe raise another problem that will draw significant attention. They have already resulted in rethinking and in some cases slowed the march towards de-regulation. Measures, such as wide area control employing GPS technology (Choo *et al.*, 2003) may be required to gain more up-to-date knowledge of the state of the system so that predictive measures can be taken to minimize the area to be affected adversely in case of major disturbances.

2.5 Fault detection and isolation (FDI) systems

There are two main research communities dealing with fault diagnosis. One of them originates from computer scientists trained in artificial intelligence. These are developing diagnostic systems based on qualitative models (de Kleer and Kurien, 2003). The other is composed of researchers trained in control and system engineering who initially dealt more with methods based on analytical models (Basseville, 2003) (Kinnaert,

2003), the so-called fault detection and isolation community (FDI), but have more recently started to deal with qualitative models as well. Interaction between the two communities has been fostered thanks to co-location of the last DX Symposium, organized by the AI community, and the SAFE-PROCESS Symposium (June 2003, Washington DC), organized by the FDI community. One of the current key problems facing the two communities is to combine the existing tools and/or develop new approaches for fault detection and isolation of hybrid (discrete/continuous) systems subject to both continuous and discrete degradations.

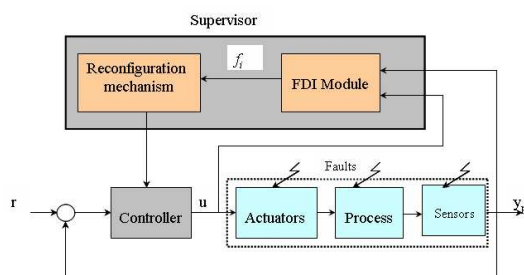

Fig. 1. Fault Detection and Isolation scheme

Missed and false detection rates, false isolation rate, detection and isolation delays are often mentioned as performance criteria for model based diagnostic systems. However, in the vast majority of the literature, such criteria are not considered in the design algorithms for FDI systems. Besides, with the exception of a few benchmarks, performance analysis of FDI systems with regard to the above mentioned properties are not often conducted. A partial explanation for this situation is the fact that diagnostic systems are made of two parts: residual generation² and decision system. A significant portion of the research work focuses on the design of one of the two modules with specific intermediate objectives. However, it is not clear that fulfillment of such intermediate objectives guarantees appropriate performance when the residual generator and the decision system are put together. More work is thus needed on design methods that account for modeling uncertainties and/or process nonlinearities while taking into account user requirements on false detection and isolation rates and detection/isolation delays.

With regard to fault tolerant control (FTC), one may distinguish passive and active methods. For the first ones, the effect of faults on the process behaviour is described as modeling uncertainties, and a robust controller is designed. This may lead to sluggish closed loop systems that do not fulfill the required performance specification under healthy working conditions. To alleviate this prob-

² Residuals are signals that are equal to zero (or have zero mean) in the absence of faults, and exhibit significant deviations from zero upon occurrence of specific fault(s).

lem, active methods can be used. They consist in performing controller reconfiguration on the basis of the information provided by a diagnostic system (Kanev, 2004). Although several case studies and benchmarks have appeared in the scientific literature over the last years, much work remains to be done for understanding precisely the interplay between the diagnostic system and the control reconfiguration mechanism. Design methods for reconfiguration mechanisms that account for factors such as fault detection and isolation delays and uncertainty in fault estimates are just starting to be developed and many open issues remain in that framework.

3. RECENT ACCOMPLISHMENTS AND TRENDS

3.1 Chemical process control

There have been numerous interesting developments in recent years which have advanced the field of chemical process control. Some important developments are merely listed in the following without trying to be comprehensive.

- Numerical methods for dynamic optimization and control (large-scale linear and nonlinear MPC algorithms, parametric programming, dynamic optimization of hybrid continuous-discrete systems, adaptive parameterization methods in dynamic optimization);
- Linear and nonlinear MPC algorithms (design for nominal stability of nonlinear MPC, robustness of linear and nonlinear MPC, decentralization of MPC, offset-free tracking of MPC, output feedback MPC, feedback MPC schemes, integration of predictive control, dynamic real-time optimization and scheduling (INCOOP project));
- Nonlinear estimation (design of nonlinear constrained estimators for stability (in the sense of convergence), techniques based on system inversion, robust estimators);
- Control system performance assessment (single and multi-loop techniques, multivariable control, stationary as well as transient operation);
- Tuning procedures for linear controllers (single loop PID, tuning rules and self-tuning algorithms, multi-loop PID schemes, tuning rules for specific configurations, multivariable (predictive) controllers);
- Monitoring and fault detection (further development and application of statistical techniques (PLS, PCA etc.) to batch and continuous processes, multi-scale monitoring methods, data mining and process visualization techniques);

- Batch process control (batch-to-batch control, NOC tracking to facilitate optimal control implementation, statistical process control methods, iterative learning control, particulate process control (e.g. crystallization), polymerisation reactor control, fed-batch fermentation control);
- New sensor technologies (image processing for feedback quality control in combustion, food processing and multiphase processes, spectroscopic techniques for in-line concentration measurement in closed-loop applications, particle size distribution measurement in closed-loop quality control);
- New areas of applications (biotechnology, biomedical, electronics processing, advanced materials, pharmaceuticals).

3.2 Mining, Mineral and Metal (MMM) processing

Since 1991, the intelligent control algorithms and the artificial intelligence methods have been successfully applied to the MMM area. Furthermore, the hybrid system modeling and control, control methodologies based on online optimization, model-on-demand or Just-in-Time modeling are among technologies which have been supported next-generation MMM control processes. They are used in nearly 40% of all applications reviewed in (Jamsa-Jounela, 2001) and therefore represent the most important methods applied in the control of the MMM process.

3.3 Power Plants and Power Systems

Wherever de-regulation has been implemented, market forces are affecting the normal operation of the power system and the nature of certain traditional functions, such as generation scheduling, economic dispatch, unit commitment, etc. is being affected significantly. Instead of performing these functions through optimal load flow, etc., the system operator will have to manage the network according to market requirements dictated by supply contracts, bids for available generation and the location of the load. The system operation function will change to that of managing the transmission network. Instead of the power flowing over the network according to the laws of nature, the power flow will have to be managed by incorporating new control devices based on power electronics. A number of new high power control devices are being developed to control the flow of active power and reactive volt-amps over the network while maintaining phase stability and voltage stability.

Distributed generation is starting to make inroads even in systems that have not been de-regulated

as such. Integration of such generation in the network is a challenging task. Wind power has already become a very significant component of the total generation in some countries.

Restructuring due to de-regulation and distributed generation has led to a number of new developments. Let us mention some examples.

3.3.1. System stability aspects in de-regulated inter-connected systems (Kurth and Welfonder, 2003).

The inter-connection of individual power systems gave rise to inter-area oscillations and they have been present since the early stages of the inter-connections. With deregulation of the energy market and expansion of the power systems, e.g. the integration of the power systems of Eastern Europe with that of the Western Europe, the oscillation behaviour has gained additional importance. It is necessary to develop techniques for the analysis of this oscillatory behaviour, effective measurement and new control technologies to improve oscillation damping.

3.3.2. Control concepts based on power electronic devices, such as FACTS for load flow adjustments, voltage quality, network stability (Cai and Erlich, 2003). With the deregulation of the electricity market, the traditional concepts and practices of power systems have changed. Better utilization of the existing power systems by installing FACTS devices is becoming imperative and such devices have started to increasingly play a major role in the operation and control of power systems. Some of the functions for which FACTS devices can be used are load flow adjustment to avoid congestion, increased capacity by higher loading of the transmission system, improved voltage quality and network stability. Techniques for the integration of these devices in the power systems and their coordination with existing controllers are being developed.

3.3.3. Emerging control schemes in distributed generation (DG) (Yokoyama and Nara, 2003) (Chung et al., 2003).

Move of the electric utilities towards deregulation has led to many new concepts being proposed for un-bundled power quality systems and their functions based on the application of DG sources, e.g. distributed power storage systems, power electronics and information technology. A few examples of these are:

- flexibility in grid structure to adjust to normal operations, outages, etc.
- highly reliable power supply using power generated by DG sources at different substations and power storage systems.

- load leveling and electricity conservation using DG power storage technology.
- advanced demand side management.

This will require the development of many new control schemes, analysis of their effectiveness and the development of individual technologies required for the new systems.

3.3.4. Development of adaptive and AI based controllers for power systems (Zhou et al., 2003) (Malik, 2004). Power systems are typical multi-variable systems with non-linear complex coupling, operate over a range of operating conditions and are subject to random disturbances, which enhance the non-linear characteristics. Also, there are a lot of uncertain factors and it is difficult to describe the process dynamics. Using the conventional linear, fixed parameter controllers, the same quality of performance under all conditions cannot be maintained.

Adaptive controllers based on the analytical and/or artificial intelligence techniques can provide improved dynamic performance of the plant by allowing the parameters of the controller to adjust as the operating conditions change. Many new schemes based on this approach have been proposed recently and many investigators are working in this area at present. One example of an adaptive controller, combining analytical and artificial intelligence techniques, and applied as a power system stabilizer (PSS) is shown in Fig. 2. It can be used to improve the stability margin of the power system compared to a conventional PSS as shown in Fig. 3.

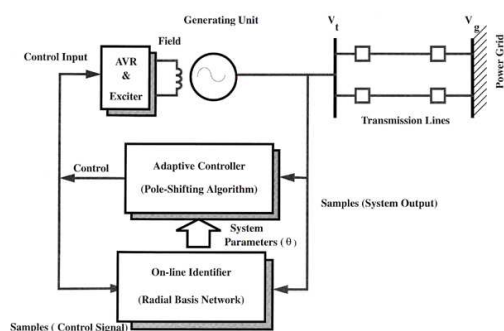

Fig. 2. Adaptive PSS with RBF NN identifier and a pole shift controller

3.3.5. New data handling schemes (Sabzevary and Iwamoto, 2003) (Tada et al., 2003). The possible interplays among independent power producers, large consumers, co-generators and utility owned generation in the power utility restructured environment requires that control systems have the ability of better assessment of all possible control actions through devices in place in the power system or by design and installation

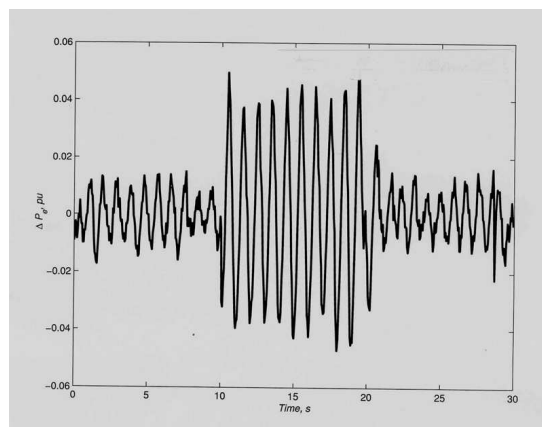

Fig. 3. Enhancement of power system stability using an adaptive PSS

of new and more flexible controls. In any control scheme, data play an extremely important role and in the new emerging environment the importance of proper data handling for power system analysis cannot be over emphasized. In addition, the amount of data to be handled has also increased many fold. New and improved techniques to enhance data handling are required to be investigated. Electrical energy is becoming the primary energy in more and more applications. New opportunities are being developed to generate electricity from renewable sources which provide energy with minimum pollution. As an example, environmental concerns are driving the automotive industry to develop hybrid and fully electric vehicles. All of these will further increase the importance of the electric power systems.

3.4 Fault detection and isolation (FDI) systems

It is not possible to provide a complete picture of the whole FDI area. We shall here mention certain of the achievements and the trends that appeared since the year 2000.

- Progress has been made in the design of diagnostic systems based on nonlinear models. The so-called fundamental problem of residual generation has been stated and solved for bilinear, state affine and control affine systems by developing appropriate tools from differential geometry and combining them with design methods for nonlinear observers. The parity space approach to residual generation has been extended to polynomial nonlinear systems by resorting to elimination theory (Groebner basis, characteristic sets and Ritts algorithm,). New developments have also appeared in nonlinear adaptive observers, which have been directly exploited in the framework of fault detection and isolation systems.

- For dealing with modeling uncertainties, various tools that appeared in the control literature have been exploited in fault detection methods. Among the recent developments, model invalidation approaches based on models that are subject to structured uncertainties, or uncertainties represented by an integral quadratic constraint can be mentioned. Kharitonov polynomials have been considered to handle transfer function models with parameters in intervals. Adaptive threshold computations have also been further developed in order to take into account the modeling uncertainties in the decision system.
- With regard to FDI based on stochastic models, residual generation methods combining subspace-based identification algorithms and statistical methods, such as the statistical local approach have been recently developed. Detection and localization of damages for monitoring the integrity of structural and mechanical systems is one of the topics for which such an approach has been used. The changes in the eigenvalues and mode shapes of the linear model describing the structure can be detected by processing the residual via a chi-square test.
- Computer intensive methods have recently started to be used for fault detection and isolation. Indeed, such methods allow one to estimate the likelihood functions and/or their gradients needed for statistical change detection tests, even for complex nonlinear dynamical systems and Markov chains. They resort to Monte Carlo simulations to achieve this goal, as exemplified in the particle filter. Bayesian estimation algorithms have also been used for fault detection and isolation in so-called multiple model structures. Such algorithms exploit both quantized and continuous data. Multiple model adaptive estimators based on a bank of linear models are linked to the above approach and have been exploited for some time for sensor and/or actuator fault detection in aerospace applications.
- With regard to active fault tolerant control, the multiple model methods are still the focus of new developments and applications. They can be associated in a natural way to the FDI methods based on multiple models. A bank of models is used, each one being associated to different operating conditions. To each model corresponds a specifically designed controller. The global control action is determined as a weighted combination of the different controller outputs, the weights indicating which models describe best the present working mode of the system as determined from the available measurements.

The way to deal with unanticipated faults in this framework has been the object of recent progress.

- Controller switching is an alternative approach in which no combination of control actions is performed. A bank of controllers is designed, each one achieving the required performance for the healthy working mode or for a pre-defined faulty situation. The most appropriate controller is placed in the loop at each time instant. Switching can be based on the information from a diagnostic system or on controller falsification based on closed-loop performance monitoring.
- More computationally demanding algorithms are developed to perform on-line optimization redesign. Once a fault has been detected and isolated (most often an actuator fault), an optimization problem is solved to determine how best to use the remaining healthy part of the process (including actuators and sensors) to achieve possibly degraded objectives. Model predictive control is one approach which has been developed and used to handle such problems.

Numerous recent papers and reports describe monitoring, diagnostic and/or fault tolerant control applications for a wide variety of devices and processes: induction motors (electrical and mechanical faults), air conditioning system (fouling and sensor monitoring), (bio)reactors, global positioning system (GPS), various automotive devices (air path of the engine, throttle control system, active suspension,), robotic manipulators, rolling mills, nuclear power plant sensors and field devices, automatic blood pressure control via anesthetics. This indicates that monitoring, diagnosis and FTC systems can be used for a broad range of applications (Murray *et al.*, 2003) (Mc. Avoy *et al.*, 2004).

4. FORECAST

4.1 Chemical process control

In the near future, industry will continue to aim at better utilization of their existing assets. Any systems and control technology supporting this objective will be of continuous and growing interest by industrial practitioners.

Performance improvement for linear multi-loop control systems: Most of the process control systems in industrial practice comprise multi-loop linear control systems. Though there is a significant demand in appropriate systematic methods to design such multi-loop (plant wide) control structures, neither significant progress nor impact on industrial practice is expected. Rather,

improved techniques and software tools for periodic control performance assessment of single and multi-variable control loops, improved methods for controller tuning as well as improved self-tuning procedures for single-loop and multi-loop controllers will continue to be of significant interest to industrial practitioners and applications oriented researchers. In addition, diagnosis methods for detecting the malfunctioning of actuators (valves in particular) will see increasing attention. Multivariable constrained control (linear MPC) will be employed more routinely. Proper embedding of such controllers into the automation hierarchy will be of increasing interest.

Modelling for monitoring and control: Data-driven and (combined data-driven and first-principles based) hybrid modelling techniques as well as grey-box closed-loop identification will be further developed to cut down model development effort but still enabling the application of largely linear model-based control techniques. Rigorous first-principles based modelling and model reduction will continue to present a challenge to the control community. These models are essential for the implementation of agile and high performance automation systems for bulk production processes operating in a large envelope of operating conditions. Besides feedback control, such models will see continuous application for soft sensor applications, monitoring and fault detection.

Model-based process operations: There is no doubt regarding the immense economical benefit of model-based techniques for operations and control in particular for nonlinear processes which have to be operated in a large region of the operational envelope. However, the cost of modelling will continue to be the major bottleneck of industrial application. Hence, there will be increasing emphasis on systematically dealing with uncertainty in first-principles models and with the adaptation of the model to the process during operation. The traditionally separate areas of set-point tracking and disturbance rejection, real-time optimization to maximize an economical profit function, and even scheduling and planning will continue to merge.

Sophisticated sensor and intelligent actuator technologies: We will see a continuing trend towards the use of process analyzers, image processes, and other high sophisticated sensors in closed loop applications. These new sensing technologies not only will provide us with more information on the process and quality variables. Rather, they will have a significant impact on the whole control system structures since they provide measurements that had to be inferred in the past via estimation. The consequences of this development for process control have still to be experienced in the near

future. A similar situation can be observed in the area of actuators. Intelligent actuators comprise of significant sensing and computing technology to perform a number of activities that traditionally had to be handled somewhere else in the automation hierarchy. For example, status information will be available for fault detection and interpretation, performance monitoring of the actuator but also of whole control loop becomes possible. Again these developments will have an impact on the architectural design of the automation and operation support systems.

Application domains: The process control community will continue to broaden its base and to shift its interest from the classical core areas of activity in the petrochemical industries towards specialty chemicals, pharmaceutical, advanced materials, particulate and even functional products as well as to food, water, energy, and waste processing plants. There will be a lot of attention towards biological systems not only in biotechnological production but also in biomedical applications. Systems biology is an emerging field that can greatly benefit from the skills in the analysis of nonlinear complex network-like systems that have been cultivated to a high level of maturity in the process systems engineering and control community. The focus will shift from the plant which is traditionally largely viewed in isolation to the larger systems envelope including the supply chain, the infrastructure systems as well as the environment. Processes in transient mode of operation (such as batch processes or continuous processes in transient phases) will see increasing interest.

Contributions to systems and control theory: The characteristics of process systems (in particular, nonlinearity, large scale, and network-like nature) are drivers for the further development of theoretical methods. Major developments in the process control community aiming at contributions to systems and control theory are to be expected in :

- nonlinear optimal control,
- combined state and parameter estimation for nonlinear systems,
- robustness analysis and robust synthesis methods for nonlinear systems,
- cross-functional integration across the vertical layers of the automation hierarchy,
- spatial decomposition, decentralization and horizontal coordination of large-scale nonlinear network-like processes,
- hybrid discrete-continuous control theory emphasizing systems with equally complex discrete as well as continuous parts.

Drivers for control and operation support systems technologies. Information technology will continue to be one of the key drivers of process control

and operation. Increasing computing power and storage capacity will facilitate the implementation of resource demanding nonlinear optimal control techniques. High bandwidth communication networks allow for remote monitoring, diagnosis, benchmarking and control of processing plants on a global scale. The entirety of production plants of multi-national industrial conglomerate become more and more a logically uniform virtual production facility which allows for any-time, any-place delivery of high quality product at the desired capacity.

4.2 Mining, Mineral and Metal (MMM) processing

Several survey papers in the Mining, Mineral and Metal (MMM) processing area have been published (Bergh *et al.*, 2001) (Craig *et al.*, 2001) (Hodouin *et al.*, 2001) (Jamsa-Jounela, 2001) (McAvoy *et al.*, 2004) that can serve as a basis for the forecast in the field. In the controller design area, an increase in applications of AI methods is noticeable. Fault diagnosis and process monitoring techniques are expanding their application in the MMM field. This includes process optimization and managing various process parameters. Recent communication and network techniques have also merged into the process monitoring systems.

MMM field techniques are focusing on building a system which can gather more information, make accurate automatic decisions and send the decisions to lower systems rapidly. Vision techniques take more important roles continuously. They can measure various materials in the process as instrumental equipment and help to monitor the process. Sensor technology based on nanotechnology will improve the accuracy and ability of systems dramatically. Environmental pollution monitoring, developing new medicine and safety techniques are examples of sensor technology applications. Moreover, using various information of the sensor helps to simplify the structure of control strategies and to improve performance. An integrated advanced control system makes a decision which includes several reasoning algorithms, modeling and analyzing techniques of the process, controller design architecture and so on. This advanced control system creates a schedule, manages various factors of the process optimally, and extends its application area to monitor and control of industrial emissions. More powerful computation ability for handling increased data of an entire plant every few seconds also becomes an issue. Internet and other fast communication techniques can change control system structure. Those are good applications for time delay control and fault-tolerant control techniques. Monitoring and managing of the plane in a remote control

room improve safety and efficiency of the system. RFID and other intelligent tag techniques have applications for automatic transportation systems. Recycling is a new field in the MMM area. Design and control of the recycling process is important to guarantee profits and preserve the environment. Detection and isolation of environmental problems has a new research area for sensor and FDI techniques.

4.3 Power Plants and Power Systems

Power systems have the unique characteristics that they are large-scale, multi-input multi-output, non-linear systems distributed over large geographical areas. The demands of de-regulation tend to be in conflict with the flow of energy that follows the laws of nature.

A direct result of the restructuring of the electric utility industry over the past 10 to 15 years is that electric power industry is now facing many problems and challenges. These challenges also present opportunities for new and innovative approaches. This coupled with the catastrophic events of 2003 in both North America and Europe has exacerbated the situation to levels that will require even more innovative solutions.

Electric power delivery system has become increasingly more complex. Management of such a system will increasingly rely on data communication network and equipment that will enable improved energy delivery and consumer services while at the same time improving the electric power security, quality, reliability and availability.

A direct result of the geographical spread of the power systems is that the required signals (directly measured or actuator computed) are available locally and they need to be sent to far locations. Controllers are also dispersed geographically and the implementation of centralized control schemes becomes expensive as it requires the transmission of signals to and from the controller locations in a fast and reliable manner. Excessive computation requirements and unavailability of dedicated, robust, high bandwidth communication links is an impediment.

From the control perspective, some of the areas in which advances are likely to occur in the near future are:

4.3.1. Integrated energy and communication systems architecture. The scope of such an architecture will include but not be limited to advancements in power system automation, more dynamic interaction with consumers, concepts such as self-healing grid that is better able to respond to fault conditions.

4.3.2. Decentralized controls possibly with some co-ordination provided by multilevel hierarchical control schemes providing centralized real-time and on-line coordination of decentralized controllers.

4.3.3. Development of transducers and communication schemes for fast signal transmission.

Some of the schemes are starting to involve satellite technology for the synchronization of control and protection actions at the geographically dispersed locations.

4.3.4. Advances in the automation of electric distribution systems.

Developments in distributed generation are placing many new demands on distribution systems. With more reliable and higher quality power expected by the consumers, the leading challenge is to balance the consumer needs with the cost of upgrading the system. One approach is to develop new architecture for distributed energy resources. This will require the development of new control systems to take care of the grid integration complexities and new power quality standards.

4.3.5. Monitoring and assessment of system security.

Secure operation is of paramount importance in the safe and economic operation of power systems. To ensure that a power system is sufficiently reliable, it must be properly designed and monitored during operation to ensure that sufficient security margin exists at all times. The traditional approach has been to study the steady state and dynamic performance of the system in an off-line operation and planning environment.

The uncertainty of predicting future operating conditions in the restructured competitive environment requires security assessment to be conducted on-line. Such assessment can provide the operator with early indication of probable trouble and provide the opportunity to take remedial action.

For accurate security assessment on-line, speed of computation becomes one major key issue. The other is the measurement of the required quantities directly from the grid. Although phasor based wide area measurements are now available, on-line dynamic security assessment will require real-time monitoring, control and protection of the power system.

Normal control actions may be classified as preventive actions taken to optimize the power system operation for the present and conditions expected in the near future. Emergency corrective control is required to prevent the power system from going unstable. Integration of phase mea-

surement units with wide area monitoring, control, and on-line dynamic security assessment requires development of new solutions in the near future.

4.3.6. New control requirements to meet demands of deregulation.

Deregulation is creating an all new set of control objectives and requirements compared to the traditional control objectives. This aspect of the power system control is still in a state of flux. The requirements are still evolving and changing continuously as more experience is gathered. Controls will not only have to meet the strictly technical requirements for efficient and reliable control and operation of the traditional vertically integrated power systems but also the additional economic objectives of profit maximization. Although at this time it may be a bit difficult to predict the shape of controls in the future from the point of view of de-regulated electricity markets, the control philosophies will certainly change.

4.4 Fault detection and isolation (FDI) systems

Three issues regarding the perspectives for fault detection and isolation and fault tolerant control systems are discussed successively, namely the influence of the advances in sensor and actuator technologies, the importance of reliability issues, and the link with maintenance policies and cost benefit analysis.

4.4.1. Influence of the advances in sensor and actuator technologies.

Self validating sensors and intelligent actuators, such as control valves equipped with internal fault detection system, will progressively penetrate the whole process industries, but also complex control systems appearing in transportation applications for instance. The diagnostic information will then be transmitted to a possibly distributed monitoring system via data networks. Hence, as far as fault diagnosis is concerned, one can foresee that the activities of the FDI community will be more oriented towards detection and isolation of process malfunction than towards sensor and actuator monitoring. Significant developments are also expected in fault accommodation and reconfiguration strategies that account for diagnostic uncertainties, detection and isolation delays, As information will be traveling over data networks, tolerance with respect to dropped or lost sensor or actuator packets will have to be considered.

4.4.2. Reliability issues.

One of the ultimate goals is to take reliability requirements into account in the design of a device or a process, including its control and monitoring system. Indeed, car

control manufacturers wish to obtain control architectures that achieve specific performance with a given reliability. Starting from the knowledge of the reliability of each component, one needs to design a device with suitable hardware and software redundancy and a control architecture including reconfiguration mechanisms that meet these objectives.

4.4.3. Maintenance policies and cost benefit analysis. From a wider perspective, requirements for safer, more reliable technical processes will increase. Stricter environmental laws and workers protection, as well as energy saving measures call for a more widespread use of on-line monitoring and reconfiguration systems. Indeed, the latter are able to detect faults before they develop into failures and to take appropriate measures to reach safe operating mode or stop the process in due time, hence decreasing the risk of pollution or casualties.

One of the limiting factors for the penetration of this technology in the process industries and in power plants may be due to the difficulty to perform cost benefit analysis. Indeed the benefits of more efficient maintenance scheduling, a reduction in downtime and the possible avoidance of an incident are difficult to quantify. More involvement of our community in the evaluation of various maintenance policies, and operating costs might help reaching more convincing arguments.

REFERENCES

- Basseville M. (2003). Model-based statistical signal processing and decision theoretic approaches to monitoring. *Preprints 5th IFAC Symp. on Fault Detection, Supervision and Safety of Technical Processes*, pp 1-12.
- Bergh L. Gl., S.L. Jamsa-Jounela and D. Hodouin (2001). State of the art in copper hydrometallurgical process control. *Control Engineering Practice*, 9, 1007-1012.
- Cai L. and I. Erlich (2003). Coordination between transient and damping controller for series Facts devices using ANFIS technology. *Preprints IFAC Symp. Power Plants and Power Systems Control, Seoul, Korea*, pp. 797-802.
- Choo J. B., K.H. Kim, D.H. Jeon, J.W. Lee, I.K. Lee and S.H. Yoon (2003). Development of wide area monitoring system using GPS. *Preprints IFAC Symp. Power Plants and Power Systems Control, Seoul, Korea*, pp. 220-223.
- Chung I-Y., S-W. Park, J-H. Choi, S-I. Moon and J-E. Kim (2003). Control schemes of utility interactive multifunctional dispersed generation. *Preprints IFAC Symp. Power Plants and Power Systems Control, Seoul, Korea*, pp. 891-896.
- Craig I. K., F.R. Camisani-Calzolari and P.C. Pistoriu (2001). A contemplative stance on the automation of continuous casting in steel processing. *Control Engineering Practice*, 9, 1013-1020.
- Hodouin D., Sl. L. Jamsa-Jounela and M.T. Carvalho (2001). State of the art and challenges in mineral processing control. *Control Engineering Practice*, 9, 995-1005.
- Jamsa-Jounela Sl. L. (2001). Current status and future trends in the automation of mineral and metal processing. *Control Engineering Practice*, 9, 1021-1035.
- Kanev S. (2004). *Robust Fault-Tolerant Control*. PhD Thesis, University of Twente, The Netherlands.
- Kinnaert M. (2003). Fault diagnosis based on analytical models for linear and non linear systems a tutorial. *Preprints 5th IFAC Symp. Fault Detection, Supervision and Safety of Technical Processes*, pp 37-50.
- de Kleer J. and J. Kurien (2003). Fundamentals of model-based diagnosis. *Preprints 5th IFAC Symp. on Fault Detection, Supervision and Safety of Technical Processes*, pp 25-36.
- Kurth M., and E. Welfonder (2003). Oscillation behaviour of the enlarged European power system under deregulated energy market conditions. *Preprints IFAC Symp. Power Plants and Power Systems Control, Seoul, Korea*, pp. 924-930.
- Malik O. P. (2004). Amalgamation of adaptive control and AI techniques: Application to generator excitation control. *Annual Reviews in Control, Vol. 28, 2004*, pp. 97-106.
- Murray R.M., K.J. Astrom, S.P. Boyd, R.W. Brockett and G. Stein (2003). Future directions in control in an information rich world. *IEEE Control Systems Magazine*, pp 20-33.
- Mc. Avoy Th., S.L. Jamsa Jounel, R. Patton, M. Perrier, H. Weber and C. Georgakis (2004). Milestone report for area 7 industrial applications. *Control Engineering Practice*, 12, pp 113-119.
- Sabzevary A. S., and S. Iwamoto (2003). Robust digital control for multi-machine power systems with data transmission delays. *Preprints IFAC Symp. Power Plants and Power Systems Control, Seoul, Korea*, pp. 856-860.
- Tada Y., T. Yamada, T. Takazawa, Y. Takahara and T. Shishido (2003). Enhancement of data handling in integrated power system analysis package, named Impact, using information technologies. *Preprints IFAC Symp. Power Plants and Power Systems Control, Seoul, Korea*, pp.823-828.
- Yokoyama R. and K. Nara (2003). Emerging control scheme and systems for practical use

of distributed generators. Panel Session 3.
*Preprints IFAC Symp. Power Plants and
Power Systems Control, Seoul, Korea*, pp.
1045-1072.

Zhou L-H., P. Han, H. Sun and Q. Guo (2003).
The application of neural network generalized
predictive control in power plant. *Preprints
IFAC Symp. Power Plants and Power Sys-
tems Control, Seoul, Korea*, pp. 1151-1154.