

*Tutorial Paper***Two-Degree-of-Freedom PID Controllers****Mituhiko Araki and Hidefumi Taguchi**

Abstract: Important results about two-degree-of-freedom PID controllers are surveyed for the tutorial purpose, including equivalent transformations, various explanations about the effect of the two-degree-of-freedom structure, relation to the preceded-derivative PID and the I-PD controllers, and an optimal tuning method.

Keywords: PID, two-degree-of-freedom control systems, process control, equivalent transformation, optimal tuning.

I. INTRODUCTION

The degree of freedom of a control system is defined as the number of closed-loop transfer functions that can be adjusted independently [1]. The design of control systems is a multi-objective problem, so a two-degree-of-freedom (abbreviated as 2DOF) control system naturally has advantages over a one-degree-of-freedom (abbreviated as 1DOF) control system. This fact was already stated by Horowitz [1], but did not attract a general attention from engineers for a long time. It was only in 1984, two decades after Horowitz's work, that a research to exploit the advantages of the 2DOF structure for PID control systems was made [2].

In [2-4], various 2DOF PID controllers were proposed for industrial use and detailed analyses were made including equivalent transformations, inter-relationship with previously proposed "advanced-type" PID (i.e., the preceded-derivative PID and the I-PD) controllers, explanations of the effects of the 2DOF structure, and a list of optimal parameters. Consequently, the results obtained were adopted by vendors [5-7], and further studies were made about optimal tuning [8-10], methods for digital implementation with magnitude and/or slope limiters [11], an anti-reset-windup method [11], and other topics arising in industrial applications [12-14].

Most of the above researches were published in Japanese and have not been translated into English

yet. The purpose of this article is to survey recent results on 2DOF controllers, so that engineers interested in this topic can easily exploit the results.

2. PRELIMINARIES

A general form of the 2DOF control system is shown in Fig.1, where the controller consists of two compensators $C(s)$ and $C_f(s)$, and the transfer function $P_d(s)$ from the disturbance d to the controlled variable y is assumed to be different from the transfer function $P(s)$ from the manipulated variable u to y . $C(s)$ is called the serial (or main) compensator and $C_f(s)$ the feedforward compensator. The closed-loop transfer functions from r to y and d to y are, respectively, given by

$$G_{yr2}(s) = \frac{P(s)\{C(s) + C_f(s)\}}{1 + P(s)C(s)H(s)}, \quad (1)$$

$$G_{yd2}(s) = \frac{P_d(s)}{1 + P(s)C(s)H(s)}. \quad (2)$$

Here, the subscript "2" means that the quantities are of the 2DOF control system.

It can be shown that the steady-state error to the unit step change of the set-point variable, $\varepsilon_{r,step}$, and the steady-state error to the unit step disturbance, $\varepsilon_{d,step}$, become zero robustly if

$$\lim_{s \rightarrow 0} C(s) = \infty, \quad \lim_{s \rightarrow 0} \frac{C_f(s)}{C(s)} = 0, \quad (3)$$

$$\lim_{s \rightarrow 0} H(s) = 1, \quad (4)$$

$$\lim_{s \rightarrow 0} P(s) \neq 0, \quad \lim_{s \rightarrow 0} \left| \frac{P_d(s)}{P(s)} \right| < \infty. \quad (5)$$

Manuscript received October 29, 2003; revised November 10, 2003; accepted November 15, 2003. Recommended by Editor Keum-Shik Hong.

Mituhiko Araki is with the Department of Electrical Engineering, Kyoto University; Kyotodaigaku-katsura, Nishikyoku, Kyoto 615-8510, Japan (e-mail: araki@kuee.kyoto-u.ac.jp).

Hidefumi Taguchi is with the Department of Mechanical Engineering, Kobe City College of Technology; 8-3 Gakuen-Higashimachi, Nishi-ku, Kobe 651-2194, Japan (e-mail: taguchi@kobe-kosen.ac.jp).

(3) imposes conditions on the controller. The simplest case that satisfies these conditions is the one that $C(s)$ includes an integrator and $C_f(s)$ does not. (4) requires that the detector is accurate in the steady state. When this condition is violated, the steady-state error given by

$$\varepsilon_{r,step} = \frac{H(0) - 1}{H(0)}, \tag{6}$$

arises, provided that (3) and (5) are satisfied. (5) is the conditions on the plant, where the first equation requires that $P(s)$ is not of differentiating and the second that the disturbance is not integrated more times than the manipulated variable. Strictly speaking, this statement is correct only when the plant is described by the minimum realization of the transfer matrix $[P(s), P_d(s)]$. From the mathematical standpoint, (3)-(5) are nothing but sufficient conditions that make the steady-state errors zero robustly. But from the industrial viewpoint they can be regarded as necessary.

3. 2DOF PID CONTROLLER AND ASSUMPTIONS ON CONTROL SYSTEMS

A 2DOF PID controller is the controller of Fig.1 with $C(s)$ being the conventional PID element and $C_f(s)$ being some appropriate element satisfying the second criterion in (3). Considering that the major advantage of the PID controller lies in its simplicity, it was proposed to include only the proportional and/or the derivative components in $C_f(s)$ [2-4]. In this case, $C(s)$ and $C_f(s)$ are given by

$$C(s) = K_P \left\{ 1 + \frac{I}{T_I s} + T_D D(s) \right\}, \tag{7}$$

$$C_f(s) = -K_P \{ \alpha + \beta T_D D(s) \}, \tag{8}$$

where $D(s)$ is the approximate derivative given by

$$D(s) = \frac{s}{I + \tau s}. \tag{9}$$

Note that the minus sign appears in $C_f(s)$ due to the reason that will be explained in Section 5. The three parameters of $C(s)$, i.e., the proportional gain K_P , the integral time T_I , and the derivative time T_D , will be referred to as “basic parameters,” and the two parameters of $C_f(s)$, i.e., α and β , as “2DOF parameters.” In the following, these five parameters will be treated as adjustable parameters. The τ in the approximate derivative (9) is set as $\tau = T_D/\delta$, where δ is called the derivative gain. It has been a traditional practice to use a fixed value of δ . We follow this tradition, partly because it has been done traditionally because of engineering convenience and partly because our numerical experiments indicated that the change of δ does not influence the optimal values of the other five parameters drastically, where some care must be taken for certain types of plants.

In order to simplify the problem, we introduce the next two assumptions that are appropriate for many practical design problems with some exceptions.

Assumption 1: The detector has sufficient accuracy and speed for the given control purpose, i.e.,

$$H(s) = 1, \quad d_m = 0. \tag{10}$$

Assumption 2: The main disturbance enters at the manipulating point, i.e.,

$$P_d(s) = P(s). \tag{11}$$

Under these assumptions, (4) and (5) are satisfied for non-differentiating plants. Since (7) and (8) satisfy (3) when T_I is finite, the 2DOF PID controller makes the steady-state errors to a step reference and a

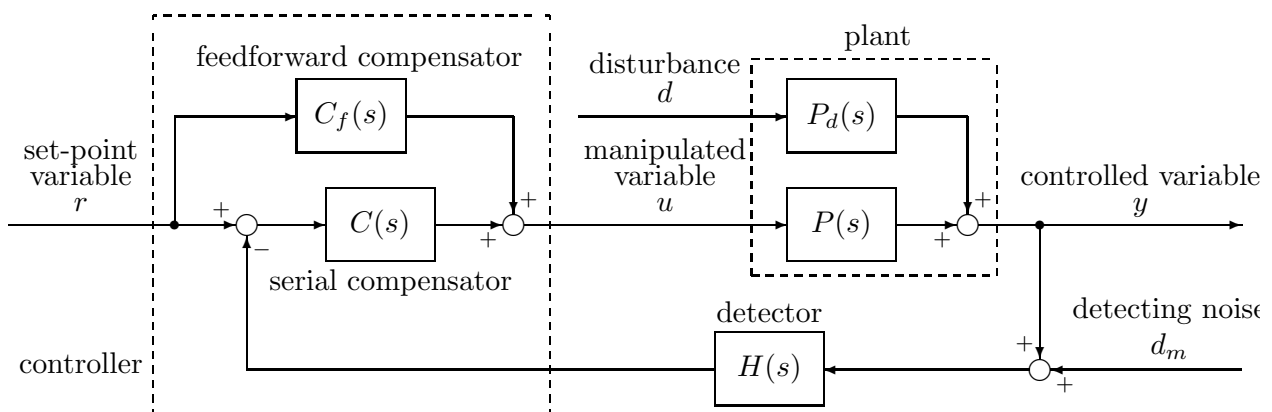

Fig. 1. Two-degree-of-freedom (2DOF) control system.

step disturbance robustly 0 if it is used in the PID or the PI action.

4. EQUIVALENT FORMS OF 2DOF PID CONTROLLERS

Fig. 2 shows a 2DOF PID control system under Assumptions 1 and 2. The controller part is a two-input one-output system where the set-point variable r and the controlled variable y are the input signals and the manipulated variable u is the output signal. Transforming this controller part, Fig. 2 can be changed equivalently to Fig. 3 - Fig. 6. The controllers in these figures are nothing but different expressions of the same 2DOF PID controller. They shall be referred to as follows:

Fig. 2 is feedforward type (FF type), because it is obtained by adding a feedforward path from y to u to the conventional PID. Fig. 3 is feedback type (FB type), because it is obtained by adding a feedback path from y directly to u to the conventional PID, where $C_b(s)$ will be called "feedback compensator." Fig. 4 is set-point filter type (Filter type), because it is obtained by inserting a filter in the set-point path of the conventional PID controller, where $F(s)$ will be called "set-point filter." Fig. 5 is filter

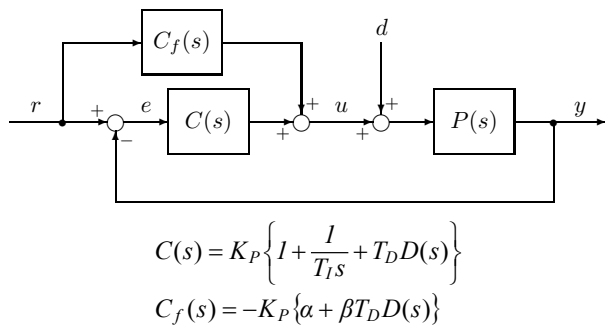

Fig. 2. Feedforward type (FF type) expression of the 2DOF PID control systems under Assumptions 1 and 2.

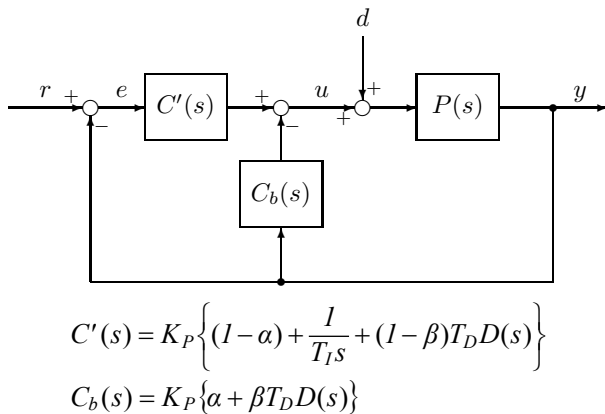

Fig. 3. Feedback type (FB-type) expression of the 2DOF PID control system.

and preceded-derivative type, because it is obtained by inserting a filter in the set-point path of the preceded-derivative type PID controller. And finally, Fig. 6 is component-separated type, because the three functional components (i.e., proportional, integral and derivative components) are separately built in.

The above equivalent transformations give basic understanding regarding the effects of the 2DOF structure from various viewpoints (see the next section). At the same time it is useful for developing an efficient algorithm in digital implementation [5, 8, 9, 11, 12], introducing nonlinear operations on the manipulated variable such as magnitude limitation, rate limitation, directional gain adjustment, etc. [5, 11, 13], realizing bumpless switching, implementing an anti-reset-windup mechanism, managing the feedforward signals coming from other systems, utilizing predictable disturbances, etc. [5, 8, 9, 11, 12], and converting the conventional PID controller already built in to the 2DOF PID [5, 8, 12, 14].

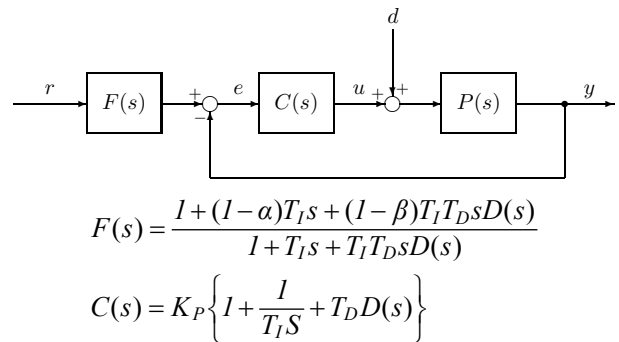

Fig. 4. Set-point filter type (Filter type) expression of the 2DOF PID control system.

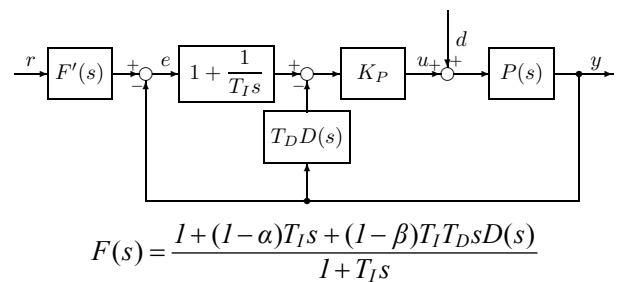

Fig. 5. Filter and preceded-derivative type expression of the 2DOF PID control systems.

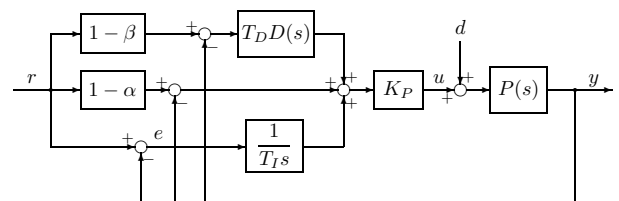

Fig. 6. Component-separated type expression of the 2DOF PID control systems.

5. EXPLANATIONS ON THE EFFECTS OF THE 2DOF STRUCTURE

The responses of the controlled variable y to the unit change of the set-point variable r and to the unit step disturbance d are called “set-point response” and “disturbance response,” respectively. They have been traditionally used as measures of the performance in tuning the PID controllers. We will use these responses in our consideration, too, and see how they are improved as a whole by the introduction of the 2DOF structure. Note that these responses are nothing but the indicial responses of the closed-loop transfer functions $G_{yr2}(s)$ and $G_{yd2}(s)$ given by (1) and (2), respectively. Here, note that Assumptions 1 and 2 are adopted so that $H(s)$ of (1) and (2) is 1 and $P_d(s)$ of (2) is $P(s)$. The simulation studies carried out for this section were made assuming that the approximate derivative (9) is nearly ideal, i.e., the derivative gain δ was set to 1000.

5.1. Problem of the conventional PID controller

Consider the conventional control system of Fig. 7, which has the 1DOF structure, under Assumptions 1 and 2. The closed-loop transfer function of this control system from the set-point variable r to the controlled variable y and that from the disturbance d to y are, respectively, given by

$$G_{yr1}(s) = \frac{P(s)C(s)}{1 + P(s)C(s)}, \quad (12)$$

$$G_{yd1}(s) = \frac{P(s)}{1 + P(s)C(s)}. \quad (13)$$

Here, the subscript “1” means that the quantities are of the 1DOF control system. These two transfer functions include only one tunable element, i.e., $C(s)$, so they cannot be changed independently. To be concrete, the two functions are bound by

$$G_{yr1}(s)P(s) + G_{yd1}(s) = P(s). \quad (14)$$

This equation shows explicitly that for a given $P(s)$ $G_{yr1}(s)$ is uniquely determined if $G_{yd1}(s)$ is chosen, and vice versa. This fact causes the following difficulty. Namely, if the disturbance response is optimized, the set-point response is often found to be poor, and vice versa. For this reason, some of the classical researches [15, 16] on the optimal tuning of PID controllers gave two tables: one for the “disturbance optimal” parameters, and the other for the “set-point optimal” parameters.

Let us see the above fact by a numerical example. Suppose the controller $C(s)$ of Fig. 7 is the PID

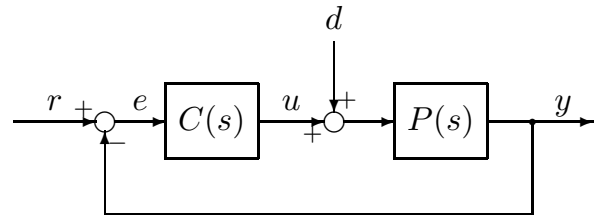
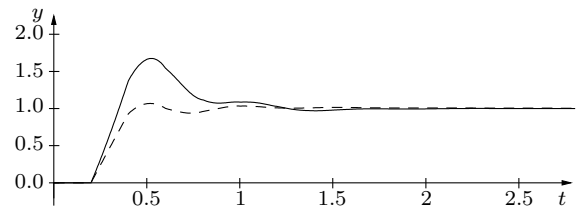
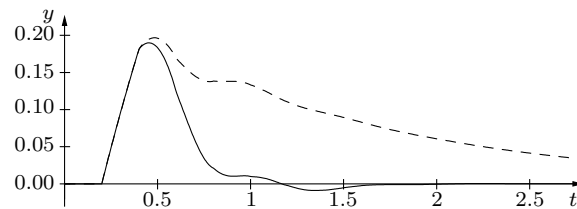

Fig. 7. Conventional 1DOF PID control system under Assumptions 1 and 2.



(a) Set-point response.



(b) Disturbance response.

Fig. 8. Responses of the conventional 1DOF PID control system.

element given by (7) and the plant is

$$P(s) = \frac{1}{1+s} e^{-0.2s}. \quad (15)$$

The disturbance optimal parameters obtained by the Chien-Hrones-Reswick (abbreviated as CHR) formula [15] are

$$K_P = 0.6, \quad T_I = 0.40, \quad T_D = 0.084. \quad (16)$$

For the above parameter setting, the closed-loop responses become as given by the solid lines in Fig. 8. They show that the disturbance response is optimal but the set-point response suffers from the overshoot larger than 50%. On the other hand, the set-point optimal parameters by the CHR formula are

$$K_P = 4.75, \quad T_I = 1.35, \quad T_D = 0.094. \quad (17)$$

For this parameter setting, the closed-loop responses become as given by the dotted lines in Fig. 8. Now, the set-point response is fine with a small overshoot but the disturbance response deteriorates substantially.

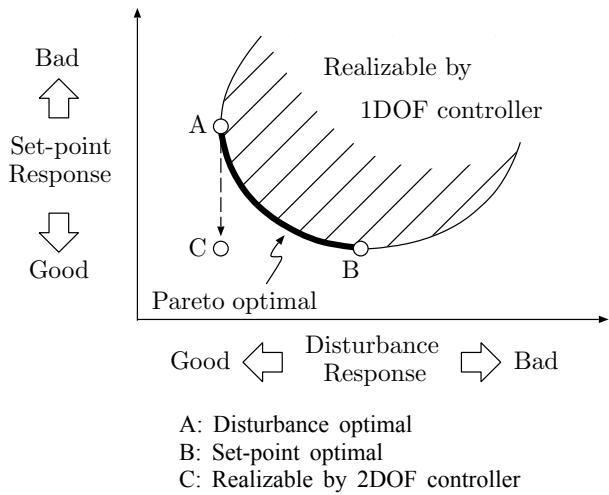

Fig. 9. Conceptual illustration of the effect of the 2DOF structure.

The situation described above can be illustrated, conceptually, as shown in Fig. 9. Only the hatched area is realizable by the conventional 1DOF PID controller. So, we cannot optimize the set-point response and the disturbance response at once. This situation has forced the engineers to choose one of the next alternatives:

- (i) to choose one of the Pareto optimal point (on the bold line of Fig. 9), or
- (ii) to use the disturbance optimal parameters and impose limitation on the change of the set-point variable (i.e., to use a rate limiter for r).

Under the process engineering situation of early days, when the set-point variable was not changed very often, the second alternative was satisfactory enough. Therefore, many of the optimal tuning methods [17-23] gave only the “disturbance optimal” parameters. However, the situation has changed in the last few decades and the process control systems are required to change the set-point variable frequently nowadays. The 2DOF PID controller offers a powerful means to cope with such a situation. Namely, it enables us to make both the set-point response and the disturbance response practically optimal at once within the linear framework, as explained in the next subsection.

5.2. Explanation based on the feedforward type expression

By comparing (1) and (2) with (12) and (13) (note that Assumptions 1 and 2 are adopted here), we obtain that the closed-loop transfer functions of the 2DOF control system are related to those of the 1DOF control systems, in terms of the FF type compensators, by

$$G_{yr2}(s) = G_{yr1}(s) + \frac{P(s)C_f(s)}{I + P(s)C(s)}, \tag{18}$$

$$G_{yd2}(s) = G_{yd1}(s), \tag{19}$$

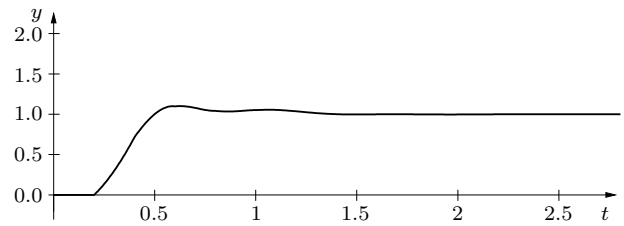

(a) Set-point response.

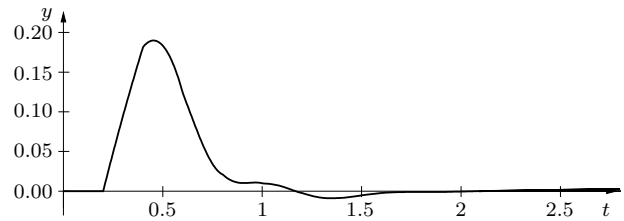

(b) Disturbance response.

Fig. 10. Responses of the 2DOF PID control system.

assuming that $C(s)$ is the same in both control systems. From this, we can observe that

- (i) the disturbance responses of the two PID control systems are the same, and
- (ii) the set-point responses differ by the amount of the second term of (18), which can be changed by $C_f(s)$.

Thus, it is expected that the set-point response is improved without deteriorating the disturbance response if we use the 2DOF controller and tune $C_f(s)$ appropriately.

Let us see a numerical example. Consider the 2DOF system in Fig. 2 and assume $P(s)$ is given by (15). Let the basic parameters K_P , T_I and T_D be as given by (16) (i.e., the disturbance optimal values of the 1DOF system), and the 2DOF parameters α and β be

$$\alpha = 0.60, \quad \beta = 0.63. \tag{20}$$

Then, we obtain the responses as shown in Fig. 10. Comparing Fig. 10 with Fig. 8, we find that the overshoot in the set-point response of the 1DOF system is completely suppressed and that the set-point response becomes practically optimal (in the sense that it is close to the optimal response of the 1DOF system). This improvement is from the effect of the second term of (18). Actually, the indicial response of the second term is shown in Fig. 11 (note that the minus sign is included in (8)). This waveform matches almost exactly to the overshoot part of the set-point response of the 1DOF control system shown in Fig. 8. By superposing these two waveforms, the set-point response of the 2DOF system becomes as given in Fig. 10.

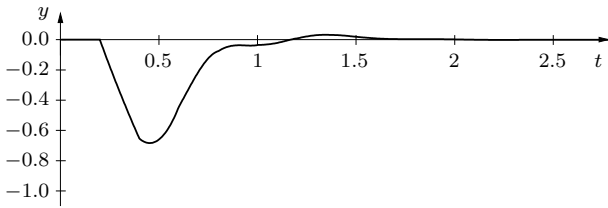

Fig. 11. Indicial response of the second term of (18).

As illustrated above, the effect of the 2DOF structure can be interpreted as a “superposition of a new term (to be exact, the second term of (18)) to the set-point response.” We studied numerically how this superposition works for the cases of representative test batches (i.e., the integrator, the first-order lag, the integrator & first-order lag, and the second-order lag all with a pure delay) which appeared in classical researches about PID tuning. As a result, we observed the following in most cases [10]:

- (i) If a 1DOF PID control system is tuned to optimize the disturbance response, the set-point response tends to have a large overshoot, and
- (ii) the overshoot can be suppressed almost completely without deteriorating the settling time by the second term of (18) in the 2DOF PID control system (the worst overshoot was 20 %).

Based on the above result, we determined to include the “minus sign” in the standard form of $C_f(s)$ (see (8)). At this point, it may be possible to say that the effect of 2DOF structure roughly appears as “cutting-off the overshoot of the set-point response,” though this interpretation does not necessarily apply to all cases.

5.3. Explanation based on the feedback type expression

The formulae of the feedback type compensators given in Fig. 3 indicate that the 2DOF control system is obtained by moving some portions of the proportional and the derivative components of the conventional PID controller to the feedback path $C_b(s)$ and the amount of the portions to be moved are given by α and β . This observation offers us another explanation about the effect of the 2DOF structure. Namely, at the beginning of control action to the step change of the set-point variable, the proportional component conveys the change as it is and the derivative component amplifies it by the factor of the derivative gain δ , if they are located in $C(s)$. This naturally causes a large overshoot of the set-point response. By moving certain portions of those components from $C(s)$ to $C_b(s)$, the overshoot is suppressed. Fig. 12 illustrates this situation, in which the set-point response of the 2DOF system is shown where the plant and the basic parameters are the same

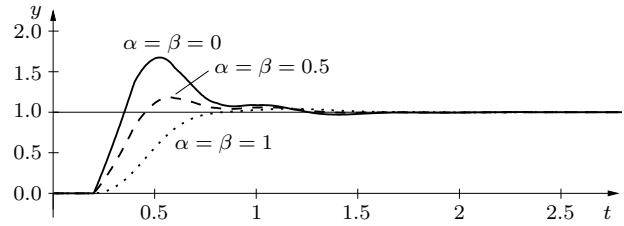

Fig. 12. Set-point responses as $\alpha = \beta$ changes.

as the previous subsection and the 2DOF parameters are changed keeping the relation $\alpha = \beta$. This figure explicitly shows that the set-point response changes from the large-overshoot waveform to the overdamped one as $\alpha = \beta$ increases.

The idea to move the proportional and/or the derivative components from $C(s)$ to $C_b(s)$ existed (and practiced) before the proposal of the 2DOF PID controller. Namely, the “preceded-derivative” PID, which has the structure of Fig. 3 with the following $C'(s)$ and $C_b(s)$

$$C'(s) = K_P \left\{ I + \frac{I}{T_I s} \right\}, \quad C_b(s) = K_P T_D D(s), \quad (21)$$

was used already in 1970's [24]. The I-PD controller, which has the structure of Fig. 3 with the following $C'(s)$ and $C_b(s)$

$$C'(s) = K_P \frac{I}{T_I s}, \quad C_b(s) = K_P \{ I + T_D D(s) \}, \quad (22)$$

was proposed by Kitamori [25] and claimed to be more suitable for parameter adjustment. These “advanced-type” PID controllers as well as the conventional PID controller can be obtained from the 2DOF PID controllers as special cases by choosing 2DOF parameters appropriately. Namely, the conventional PID controller is obtained by setting $\alpha = \beta = 0$, the preceded-derivative PID by setting $\alpha = 0$ and $\beta = 1$, and the I-PD by setting $\alpha = \beta = 1$.

5.4. Explanation based on the set-point filter type expression

As explained in Subsection 5.1, one of the alternatives to solve the tuning problem of the conventional PID controller was to use the disturbance optimal parameters and limit the rate of the change in the set-point variable. Namely, when a step-change of the controlled variable y is requested, the set-point variable r is changed as given in Fig. 13 in the actual operation. The set-point filter type expression reveals that the same sort of operation is carried out in the 2DOF PID controller, too. Fig. 14 gives the indicial response of the set-point filter $F(s)$ of Fig. 4,

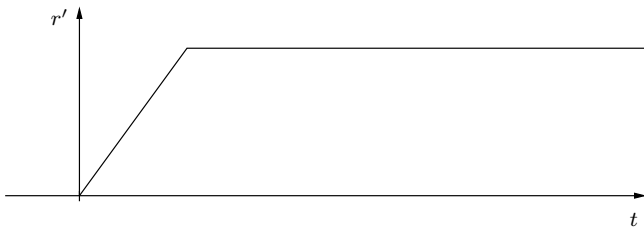
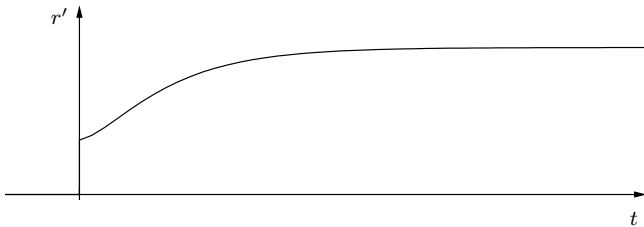

Fig. 13. Conventional "rate-limiting" operation.

Fig. 14. Indicial response of the set-point filter $F(s)$.

where the basic parameters and the 2DOF parameters are given by (16) and (20), respectively. Comparing Fig. 14 with Fig. 13, we can see that the basic strategy to avoid the large overshoot is the same in the case of the 2DOF PID method and in the case of the operational method for the conventional PID. However, the two methods sharply differ in that the 2DOF PID realizes this strategy within the linear framework whereas the operational method for the conventional PID implements it as a nonlinear (conditional) operation.

5.5. Remarks about the effect of the 2DOF structure

As explained in Subsection 5.3, the idea of removing the proportional and/or derivative components from the serial path $C(s)$ to the feedback path $C_b(s)$ existed before the proposal of the 2DOF PID controller. In addition, as explained in Subsection 5.4, the strategy which is employed in the 2DOF PID is basically the same with the one used in the classical method of operation which has been practiced in application of the conventional PID. These facts might give an impression that the 2DOF PID does not involve anything novel. But it must be noted that the idea of the 2DOF PID controller enables us to view the classical contrivances in a unified way, i.e.:

- (i) It was clarified that the conventional PID, the preceded-derivative PID, and the I-PD controllers are nothing but special cases of one general class of controllers (i.e., the 2DOF PID). In other words, these 3 controllers were homotopically connected by the introduction of the idea of 2DOF PID structure.
- (ii) It was clarified that the "rate limiting" operation rule given in Fig. 13 can be realized within the linear framework, and essentially has the same sort of effect with the preceded-derivative and the I-PD structure. Thus, we are given the freedom of trans-

forming the controller equivalently in a various fashion and facilitated with many ways of introducing other necessary nonlinear operations such as magnitude limitation, rate limitation, bumpless switching, anti-reset windup operation, etc.

Some remarks from the modern theoretic point of view are to be made. The effect of the 2DOF structure is obtained by re-allocation of the zeros of the transfer function from the set-point variable r to the controlled variable y . It must be also noted that the 2DOF structure is realized by the feedforward compensator $C_f(s)$, so is effective only in the range where the sensitivity function is small enough. This means that it is fruitless to try to adjust minute parts of the response waveform by $C_f(s)$. This fact justifies the strategy to use a simple element as $C_f(s)$.

6. OPTIMAL TUNING

In this section, we study the tuning problem of the 2DOF PID controllers using the feedforward type expression of Fig. 2. We employ the set-point response and the disturbance response, defined in the previous section, to evaluate the performance of the control system as have been traditionally done in the tuning of conventional PID controllers.

6.1. Basic strategy

The set-point response is nothing but the indicial response of the closed-loop transfer function $G_{yr2}(s)$ given by (1), and the disturbance response is that of $G_{yd2}(s)$ given by (2), as stated in the previous section. Equation (1) tells that the disturbance response is completely determined by the serial compensator $C(s)$. On the other hand, equation (2) tells that the set-point response depends on both $C(s)$ and $C_f(s)$, so can be still adjusted by $C_f(s)$ even after $C(s)$ is fixed. This observation suggests the next tuning method.

Two-step Tuning Method:

Step 1: Optimize the disturbance response by tuning $C(s)$ (i.e. by adjusting the basic parameters K_P , T_I , and T_D).

Step 2: Let $C(s)$ be fixed and optimize the set-point response by tuning $C_f(s)$ (i.e. by adjusting the 2DOF parameters α and β).

The above method has advantages that the classical result about PID tuning can be utilized in Step 1, that the number of parameters to be optimized at once is not large (i.e., 3 and 2), and that we can maintain intuitive understanding about what are going on in each

step. On the other hand, this method does not necessarily guarantee to give the “overall optimal.” To be concrete, the major characteristics (for instance, poles) of the system are determined at the first step, and, if that is chosen too extremely, tuning in the second step becomes difficult so that we can only attain a very poor set-point response. This phenomena are actually observed if we remove Assumption 2 of Section 3 and apply the two-step tuning method to the case where $P_d(s)$ has a longer time constant than $P(s)$. In such a case, we have two alternatives: to maintain the two-step strategy and modify the result appropriately, or to carry out the overall tuning (i.e., to optimize the 5 parameters at once). This sort of problem is studied in [26]. In the following, we use the above two-step tuning method to calculate optimal parameters under Assumption 2.

6.2. Frequency Domain Performance Index for PID Tuning

In this subsection, we explain a tuning method that uses a frequency domain performance index. As explained before, we can use the results of classical researches [15-23] for Step 1. However, criteria used in those researches are under influence of intuitive judgment of the researchers and are not easy to be extended to Step 2. So, the following alternative [10] will be adopted. Namely, first, such a performance index is constructed that the optimized results match with the classical “optimal” for the case of the conventional PID control systems. Then, that performance index will be used for optimization of Steps 1 and 2.

As a general form of the performance index, consider the functional

$$J[\lambda, p; H(s)] = \int_0^\infty \left| \lambda(\omega) \left\{ \frac{d^p H(s)}{ds^p} \right\}_{s=j\omega} \right|^2 d\omega. \quad (23)$$

Here, $H(s)$ is the function, such as $G_{yd}(s)/s$ or $G_{er}(s)/s$, which gives the response of the “error e ” to a step input in the Laplace domain. Equation (23) can be understood as follows. When $\lambda(\omega) = 1$, the next equation can be derived via Parseval’s formula:

$$J[1, p; H(s)] = \pi \int_0^\infty \left\{ t^p e_{step}(t) \right\}^2 dt. \quad (24)$$

This type of squared time-weighted integral error has been used in many literatures on PID tuning. A distinctive feature in (23) is introduction of the frequency weight $\lambda(\omega)$. By using $\lambda(\omega)$ that has larger values in the high frequency domain, we can suppress the feedback gain in the high frequency range

and, in most cases of the PID control applications, prevent the system to become oscillatory. By applying the above type of performance index with various $\lambda(\omega)$ and p to representative test batches, it was found [10] that

$$\lambda(\omega) = \omega^{1/4}, \quad p = 2 \quad (25)$$

makes the conventional PID control systems the “optimal” in the classical sense, which implies

- (i) the overshoot is less than 20 %, and
- (ii) the settling time is almost the same with or less than that of the “optimal” system tuned by the CHR method.

We will use the performance index (23) with $\lambda(\omega)$ and p given by (25) for tuning the 2DOF PID control system as follows:

Step 1: Adjust the basic parameters K_P , T_I and T_D so that $J[\lambda, p; G_{ed2}(s)/s]$ is minimized.

Step 2: Keeping the basic parameters be fixed, adjust the 2DOF parameters α and β so that $J[\lambda, p; G_{er2}(s)/s]$ is minimized.

Here, G_{ed2} is the closed-loop transfer function from the disturbance d to the error e and G_{er2} is that from the set-point variable r to e , respectively, given by

$$G_{ed2}(s) = -G_{yd2}(s), \quad G_{er2}(s) = 1 - G_{yr2}(s). \quad (26)$$

6.3. Optimal parameters

The optimal parameters were calculated for the next 7 types of test batches assuming that the derivative element $D(s)$ is an ideal one (i.e., the derivative gain δ is infinite).

$$P_1(s) = \frac{e^{-Ls}}{1 + Ts}, \quad (27)$$

$$P_2(s) = \frac{e^{-Ls}}{(1 + Ts)^2}, \quad (28)$$

$$P_3(s) = \frac{e^{-Ls}}{(1 + Ts)^3}, \quad (29)$$

$$P_4(s) = \frac{e^{-Ls}}{s}, \quad (30)$$

$$P_5(s) = \frac{e^{-Ls}}{s(1 + Ts)}, \quad (31)$$

$$P_6(s) = \frac{e^{-Ls}}{s(1 + Ts)^2}, \quad (32)$$

Table 1. Optimal parameters for $P(s) = \frac{e^{-Ls}}{1+Ts}$.

L/T	K_P	T_I/T	T_D/T	α	β
0.1	12.57	0.22	0.04	0.64	0.66
0.2	6.32	0.40	0.08	0.61	0.64
0.4	3.21	0.69	0.16	0.56	0.61
0.8	1.68	1.09	0.30	0.47	0.54

Table 2. Optimal parameters for $P(s) = \frac{e^{-Ls}}{(1+Ts)^2}$.

L/T	K_P	T_I/T	T_D/T	α	β
0.1	47.58	0.40	0.19	0.66	0.84
0.2	15.18	0.72	0.31	0.64	0.81
0.4	5.52	1.19	0.47	0.60	0.76
0.8	2.34	1.74	0.64	0.52	0.67

Table 3. Optimal parameters for $P(s) = \frac{e^{-Ls}}{(1+Ts)^3}$.

L/T	K_P	T_I/T	T_D/T	α	β
0.1	12.76	0.98	0.86	0.64	0.79
0.2	6.65	1.44	0.89	0.62	0.77
0.4	3.58	1.93	0.94	0.57	0.73
0.8	1.98	2.43	1.04	0.50	0.65

Table 4. Optimal parameters for $P(s) = \frac{e^{-Ls}}{s}$.

$K_P \cdot L$	T_I/L	T_D/L	α	β
1.253	2.39	0.414	0.66	0.68

Table 5. Optimal parameters for $P(s) = \frac{e^{-Ls}}{s(1+Ts)}$.

L/T	K_P	T_I/T	T_D/T	α	β
0.1	41.31	0.42	0.22	0.67	0.85
0.2	12.04	0.81	0.38	0.66	0.84
0.4	3.93	1.55	0.62	0.66	0.82
0.8	1.50	2.87	0.90	0.66	0.78

Table 6. Optimal parameters for $P(s) = \frac{e^{-Ls}}{s(1+Ts)^2}$.

L/T	K_P	T_I/T	T_D/T	α	β
0.1	5.72	1.17	1.30	0.67	0.81
0.2	2.97	1.95	1.33	0.67	0.80
0.4	1.60	3.01	1.41	0.67	0.79
0.8	0.88	4.57	1.55	0.67	0.77

$$P_7(s) = \frac{e^{-Ls}}{1+Ts+T^2s^2} \tag{33}$$

Table 7. Optimal parameters for $P(s) = \frac{e^{-Ls}}{1+Ts+T^2s^2}$.

L/T	K_P	T_I/T	T_D/T	α	β
0.1	40.69	0.41	0.22	0.66	0.85
0.2	11.45	0.74	0.40	0.64	0.84
0.4	3.39	1.17	0.67	0.57	0.80
0.8	1.06	1.38	1.06	0.35	0.69

The results are as listed in Tables 1 - 7, while formulae giving those values are given in [27]. In concern with those numerical results, we can observe the following.

By carrying out simulation study, we could find the following.

- (i) Generally, change of the 2DOF parameters α and β are not very large.
- (ii) Sensitivity of the response to the change of the controller parameters is not very high at the optimal point except the case of the oscillatory plant (33). So, Tables 1-6 are expected to work fairly well so long as the type of the real plant fits one of the test batches (27)-(32).
- (iii) For the oscillatory plant given by (33), sensitivity of the responses to the change of the controller parameters was found considerably high. So, it is recommended not to rely upon Table 7 for this class of plants, but to carry out deliberate tuning.
- (iv) If the derivative gain δ is finite and decreases, the optimal values tend to change as follows, where the change is small for the cases of the plants (27) and (30) but is significant, specifically about the proportional gains, for (28), (29), (31), and (32).

K_P becomes smaller, T_I becomes larger, and T_I becomes smaller.

α becomes larger, and β becomes smaller.

7. CONCLUSIONS

In this paper, some of the researches on the two-degree-of-freedom PID controllers were surveyed for the tutorial purpose, including the optimal parameter values of the controller in the three term (i.e., PID) action for 7 classes of test batches. As for the optimal parameter values in the case of the PI action, the readers are referred to [27]. To determine the optimal parameter values for the case of the PD action, we cannot extend the method as explained in Section 6 directly, but need to make a little more consideration, because the steady state error, $\varepsilon_{d,step}$, to the step disturbance does not become 0 in this case. Such

consideration is made in [28]. If the readers want to be more acquainted with theoretical results on the PID controller in general, they are referred to [29] and [30]. As for the conditions (3)-(5) that guarantee zero steady-state errors, they are referred to [31].

The 2DOF PID controller can solve the problem of the conventional PID controller that the optimal tuning for the disturbance response and the one for the set-point response are not compatible in most cases of practical importance. This problem was not very important in the early days of PID application when the change of the set-point variable was not required very often, but is very important in the modern practice of process control where the change of the set-point variable is frequently required. This article is intended to be a handy reference for engineers who are faced to such a problem.

REFERENCES

- [1] I. M. Horowitz, *Synthesis of Feedback Systems*, Academic Press, 1963.
- [2] M. Araki, "PID control system with reference feedforward (PID-FF control system)," *Proc. 23rd SICE (Society of Instrument and Control Engineers) Annual Conference*, pp. 31-32, 1984.
- [3] M. Araki, "On two-degree-of-freedom PID control systems," *SICE Research Committee on Modeling and Control Design of Real Systems*, 1984.
- [4] M. Araki, "Two-degree-of-freedom control system: part I," *Systems and Control*, vol. 29, pp. 649-656, 1985.
- [5] K. Hiroi, "Two-degree-of-freedom PID control system and its application," *Instrumentation*, vol. 29, pp. 39-43, 1986.
- [6] M. Namie, T. Ueda, T. Tsukabe, and H. Taguchi, "Two-degree-of-freedom PID controller used for temperature control: Simultaneity reference response and disturbance response," *OMRON Technics*, vol. 28, pp. 285-291, 1988.
- [7] OMRON Corporation, *Electrical Temperature Controller*, Catalog No. SCSS-045, 1988.
- [8] K. Hiroi and K. Yonezawa, "Reference-filter type two-degree-of-freedom PID control system," *Proc. 24th SICE Annual Conference*, pp. 217-218, 1985.
- [9] K. Hiroi and Y. Yamamoto, "Component-separated type two-degree-of-freedom PID control system," *Proc. 24th SICE Annual Conference*, pp. 219-220, 1985.
- [10] H. Taguchi, M. Doi, and M. Araki, "Optimal parameters of two-degree-of-freedom PID control systems," *Trans. SICE*, vol. 23, pp. 889-895, 1987.
- [11] K. Hiroi and K. Nagakawa, "Improvement of a digital PID algorithm with rate limitation on MV change," *Proc. 28th SICE Annual Conference*, pp. 243-244, 1989.
- [12] K. Hiroi, A. Nomura, A. Yoneya, and Y. Togari, "Advanced two-degree-of-freedom PID algorithm," *Proc. 29th SICE Annual Conference*, pp. 49-50, 1990.
- [13] M. Kanda and K. Hiroi, "Super two-degree-of-freedom PID algorithm," *Proc. 30th SICE Annual Conference*, pp. 465-466, 1991.
- [14] S. Yamazaki and K. Hiroi, "Application of reference-filter type 2DOF PID to boiler control," *Instrumentation*, vol. 30, pp. 114-119, 1987.
- [15] K.L. Chien, J. A. Hrones, and J. B. Reswick, "On the automatic control of generalized passive systems," *Trans. ASME*, vol. 74, pp. 175-185, 1952.
- [16] R. Kuwata, "An improved ultimate sensitivity method and PID: characteristics of I-PD control," *Trans. SICE*, vol. 23, pp. 232-239, 1987.
- [17] G. H. Cohen and G. A. Coon, "Theoretical consideration of retarded control," *Trans. ASME*, vol. 75, pp. 827-834, 1953.
- [18] P. Hazebroek and B. L. van der Waerden, "Theoretical considerations on the optimal adjustment of regulators," *Trans. ASME*, vol. 72, pp. 309-315, 1950.
- [19] P. Hazebroek and B. L. van der Waerden, "The optimal adjustment of regulators," *Trans. ASME*, vol. 72, pp. 317-322, 1950.
- [20] A. M. Lopez, J. A. Miller, C. L. Smith, and P. W. Murrill, "Tuning controllers with error-integral criteria," *Instrumentation Technology*, vol. 14, pp. 57-62, 1967.
- [21] J. A. Miller, A. M. Lopez, C. L. Smith, P. W. Murrill, "A comparison of controller tuning techniques," *Control Engineering*, vol. 14, pp. 72-75, 1967.
- [22] Y. Takahashi, *Automatic Control*, Kagaku-Gijutsu-Sha, 1949.
- [23] W. A. Wolfe, "Controller settings for optimum control," *Trans. ASME*, vol. 73, pp. 413-418, 1951.
- [24] S. Miyazaki, "The practice of process control (19th): Direct digital control and its merits," *Automation*, vol. 26, pp. 102-107, 1981.
- [25] T. Kitamori, "A method of control system design based upon partial knowledge about controlled processes," *Trans. SICE*, vol. 15, pp. 549-555, 1979.
- [26] H. Taguchi and M. Araki, "On tuning of two-degree-of-freedom PID controllers with consideration on location of disturbance input," *Trans. SICE*, vol. 38, pp. 441-446, 2002.
- [27] H. Taguchi and M. Araki, "Two-degree-of-freedom PID controllers: Their functions and optimal tuning," *Proc. IFAC Workshop on Digital Control: Past, Present and Future of PID Control*, pp.91-96, 2000.

- [28] H. Taguchi and M. Araki, "Optimal tuning of two-degree-of-freedom PD Controllers," *The 4th Asian Control Conference*, pp.268-273, 2002
- [29] K. J. Åström and T. Hägglund, *PID Controllers: Theory, Design, and Tuning (2nd Edition)*, Instrument Society of America, 1985.

- [30] N. Suda, *PID Control*, Asakura Shoten, 1992.
- [31] M. Araki and H. Taguchi, "Two-degree-of-freedom PID controllers," *Systems, Control and Information*, vol. 42, pp. 18-25, 1998.



Mituhiko Araki was born on September 25, 1943. He received the B.E., M.E., and Ph.D. degrees, all in electronic engineering, from Kyoto University, Kyoto, Japan, in 1966, 1968, and 1971, respectively. Since 1971 he has been with the Department of Electrical Engineering,

Kyoto University, where he is currently a Professor. His research interests have been in systems and control theory and their industrial applications, but recently he is applying modern control technologies, in corporation with medical doctors, to medical problems such as hypnosis control during surgery. Dr. Araki is the editor of *Automatica* for control system applications.



Hidefumi Taguchi was born on November 10, 1959. He received the B.Eng. degree in 1982 and the M.Eng. degree in 1984, both in mechanical engineering, from Nagaoka University of Technology. From 1984 to 1992. He worked for OMRON Corporation, where he was engaged in

developments of thermo-controllers and electric-power steering systems. Currently, he is an Associate Professor at the Department of Mechanical Engineering, Kobe City College of Technology. His research interests include PID control systems and advanced process control.