

5. REFRIGERATION PROCESS CONTROL: A PRAGMATIC DESIGN APPROACH

The simulation model described in Chapter 4, is used here to examine the control performance of the two-stage refrigeration system. Several control configurations are examined. These configurations were chosen by heuristics and common engineering practice. These choices will be evaluated later by comparing their performance to that of the choices recommended by comprehensive control analysis in Chapter 6. Performance is compared on the basis of ISE value of process stream outlet temperature TP_{1o} .

5.1. CONTROL OBJECTIVES

An analysis of the relationships in the two-stage refrigeration system shows the availability of 5 degrees of freedom for control purposes, i.e. up to 5 control loops can be implemented on the system.

Examining the open loop responses for all potential controlled variables after a disturbance shows that liquid levels in the vessels are non-self-regulatory. Therefore two of the levels must be controlled to prevent the vessels from emptying or filling completely. Since it is also necessary to ensure that the tubes are submerged in the evaporators above a certain value, an obvious choice is to control the levels L1 and L2 in the two evaporators.

This leaves up to three candidate controlled variables still to be chosen. Obvious targets are the pressures and temperatures in the vessels and in the condenser. In this model, the vapour pressure and temperature in each vessel are related via the Antoine Equation. Consequently controlling one of these variables fixes the other automatically. Here, the three pressures are chosen as the three remaining controlled variables.

In the current work, the main control objective has been chosen as the control of the process stream output temperature TP1o leaving the LP evaporator. However, with the 5 degrees of freedom available already used controlling two levels and three pressures, the implementation of this objective requires either cascading this temperature control to another controller, or replacing another controlled variable with this one.

5.2. CONTROL CONFIGURATIONS

With five degrees of freedom in the two-stage refrigeration system available for control, the total possible control configurations is large. For example, with a specific set of five controlled and five manipulated variables, 120 possible pairings exist. This issue was discussed earlier in Chapter 2, Based on heuristics and common engineering practice and taking into account the control objectives, the number of workable / practical configurations can be reduced significantly. The chosen configurations will be validated later by a comprehensive control analysis (see Chapter 6). In this study, the control configurations considered were classified into three main approaches. Under each approach, several cases were examined to assess their performance, and to determine whether they can improve the control.

5.2.1. Approaches

Several approaches were explored in designing suitable control schemes for the two-stage refrigeration system. Initial studies (e.g. Wilson and Jones, 1994; Dacey, 1994) did not consider the control of the process stream temperatures as a primary objective and thus approached the control problem from a different perspective

compared to the situations in which the control of this temperature is more important. Three approaches have been examined in this thesis: a conventional approach, a direct temperature control approach, and a cascade temperature control approach.

5.2.1.1. Conventional Approach

The term “conventional” means the control schemes in which the process stream temperature TP_{1o} is not of a primary control objective, and therefore is not controlled directly, rather is controlled indirectly by controlling both the pressure $P1$ and the level $L1$ in the LP vessel, and by the manual input of the operator who usually controls the temperature manually by adjusting the set-point of the $P1$ control loop.

The basic control scheme applied on the system is simply composed of five control loops controlling the two levels in the evaporators and the three pressures. This scheme is shown in Figure 5.1, and is referred to as the five-loop Base Case in subsequent discussions.

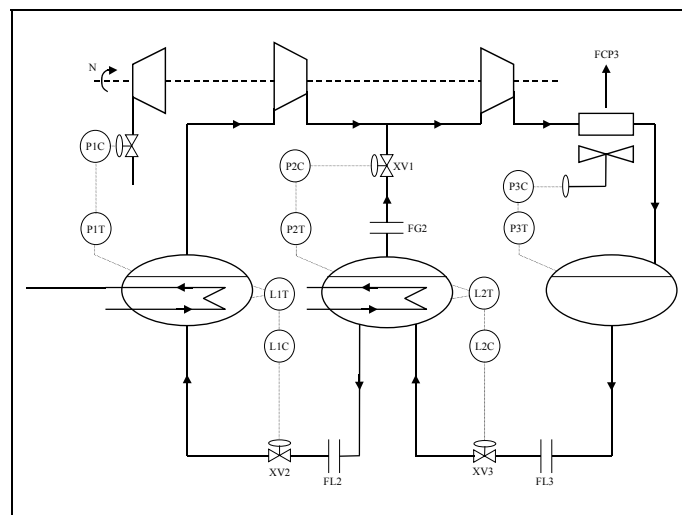

Figure 5.1: Conventional Control Approach

These five control loops are paired as follows:

1. The level in the LP evaporator $L1$ is paired with the control valve $XV2$
2. The level in the IP evaporator $L2$ is paired with the control valve $XV3$

3. The pressure in the LP evaporator P1 is paired with the compressor speed N
4. The pressure in the IP evaporator P2 is paired with the vapour control valve XV1
5. The pressure in the condenser/receiver P3 is paired with the condenser cooling FCP3

Applying this approach, this scheme has been used previously by Dacey (1994), Wilson and Jones (1994), and Asmar *et al.* (1997; 1998a). In this study, it is used as a basis for comparison with all control cases applied using each alternative approach.

5.2.1.2. Direct Temperature Approach

In this approach, controlling the process stream temperature TP1o is the primary objective. The control configuration applied here is simply the basic conventional control scheme described earlier, but with the control loop P1-N removed and replaced by TP1o-N loop. This scheme is shown in Figure 5.2. In this control arrangement, the temperature measurement is sent to a temperature controller, which then manipulates the compressor speed N to respond to the disturbance.

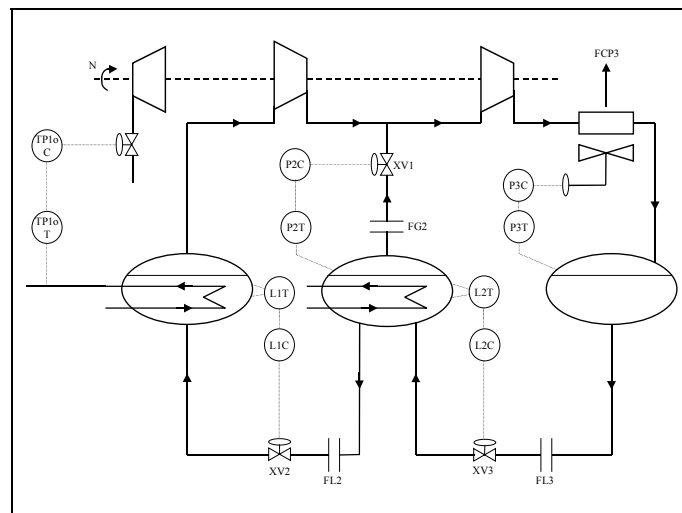

Figure 5.2: Direct Temperature Control Approach

5.2.1.3. Cascade Temperature Approach

In this method, an additional process measurement, closely related to the expected disturbance, is taken as “fast acting control” on this variable incorporated as an inner loop. The inner controlled variable should have a significant effect on the main controlled variable and be cheap to measure.

the Five-Loop Base Case, four additional cases were examined. A description of these cases is given in the subsequent sections, and in Figures 5.4 to 5.7.

5.2.2.1. Cascade Liquid Flow (Case C/Liq)

An earlier study by Asmar *et al.* (1997) showed that using the liquid flowrates into the evaporators as manipulated variables to control the levels in these evaporators will reduce the interaction exhibited within the system. To achieve the recommendation, a cascade control arrangement is introduced by manipulating the set points of cascade flow controllers instead of the control valves (see Figure 5.4). This is a common practice in level control as the flow dynamics are much faster than the level dynamics, and therefore the flow measurement is used to enhance the level control. It is used usually to make the operation easier for the operator when the cascade is opened (Marlin, 1995).

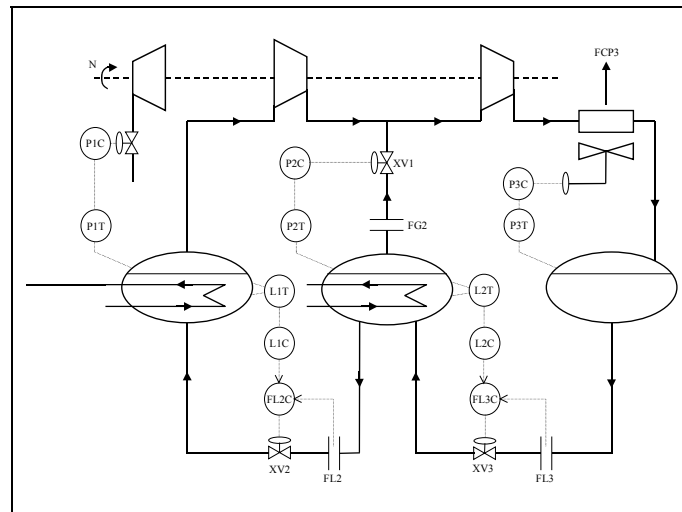

Figure 5.4: Cascade Liquid Flow Case (C/Liq)

The cascaded control structure used here replaces the two conventional control loops with cascade liquid flow control loops, where the flow set points are set by the level (master) control loops. In this scheme, the flow (slave) control is assumed to be perfect, and this can be justified as the flow response is much faster than the level response. Hence any upstream pressure deviation does not affect the liquid flow delivered by the control valve, as the valve opening will adjust rapidly to any change in the pressure maintaining the same flowrate.

5.2.2.2. Cascade Vapour Flow (Case C/Vap)

The cascaded control structure used here replaces intermediate pressure P2 loop with a cascade vapour flow control loop, where the flow set point is set by the pressure (master) control loops (see Figure 5.5). In this scheme also, the flow (slave) control is assumed to be perfect. All other four basic loops are left unchanged.

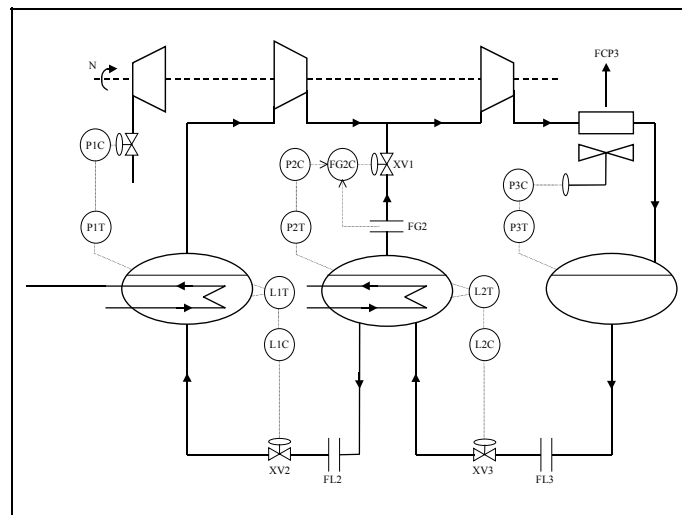

Figure 5.5: Cascade Vapour Flow Case (C/Vap)

5.2.2.3. Case L1/L3

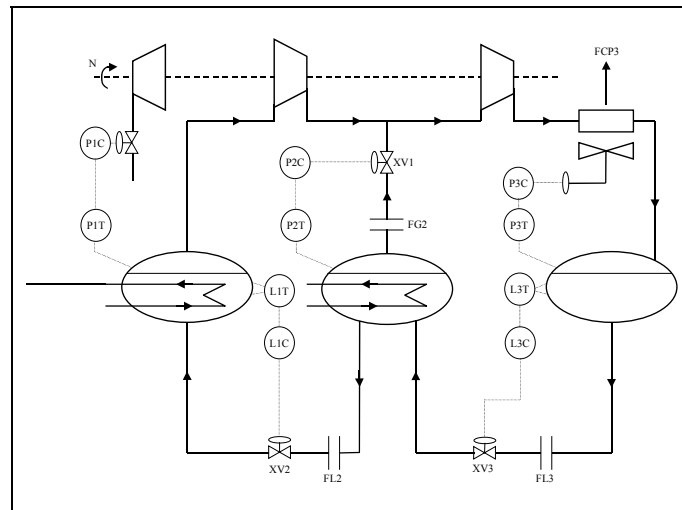

Figure 5.6: Case L1/L3

In this scheme (Figure 5.6), the level in the IP evaporator L2 is left uncontrolled. Instead, the level in the receiver L3 is controlled, and is paired with the valve XV3. All other four basic loops are left unchanged as in the Base Case.

1. **Controlled variable performance:** here, a performance criterion is chosen as a basis for the comparison of alternative control designs, and to evaluate which design exhibits better performance. Numerous criteria exist, which lead to different control designs.

Simple performance criteria are based on some characteristic features of the closed loop response of the system. They include the settling time, the overshoot, the rise time, the decay ratio, and the oscillation of the transient. Each one of these characteristics can be used as a basis on which to tune the controller. However, designing controllers based on more than one criterion leads to conflicting response characteristics, and therefore, a compromise is needed.

More complicated performance criteria use the entire closed loop response to evaluate the performance. The most often used are:

- a. Integral square error (ISE)
- b. Integral absolute error (IAE)
- c. Integral time-weighted absolute error (ITAE)

2. **Manipulated variable performance:** here, the variation in the manipulated variables is set within defined limits to prevent saturation.

To evaluate the control performance, a specific performance criterion is chosen, which shows the best performance for the controlled variables, while living within the performance specifications of the manipulated variables at the same time.

In this work, several methods were examined before a final tuning procedure was determined. In examining the methods, the controlled variable performance objective chosen was to minimise the ISE of the process output temperature in the LP evaporator TP10, while ensuring all other controlled variables perform satisfactorily relative to a set criterion, and none of the manipulated variables is pushed against its limits. To ensure this, the dimensionless controller gain was set to 10, which is the maximum range on most conventional control instruments. Thus the maximum controller gains were limited by the following relationship:

$$K_c \leq 10 \frac{\text{manipulated variable range}}{\text{measurement (controlled variable) range}} \quad (5.1)$$

This is a common practice in control design (Marlin, 1995), which ensures the physical limitations of the measurement instruments and manipulated variables such as valves are respected. The ranges specified here depend on the physical dimensions of the vessels when specifying the level ranges and on common engineering practice in specifying the pressure and temperature ranges. Tables 5.1 and 5.2 show the ranges for all potential manipulated and measured variables in the two stage refrigeration system.

Table 5.1: Ranges for measured variables

| Variable | L1 | L2 | L3 | P1 | P2 | P3 | TP1o | FL2 | FL3 | FG2 |
|----------|----------------|----------------|----------------|-----|-----|-------|---------|--------|--------|--------|
| | m ³ | m ³ | m ³ | bar | bar | bar | K | kg/s | kg/s | kg/s |
| Range | 2.9-6.4 | 0.6-1.6 | 6.9-13.7 | 0-2 | 3-6 | 12-18 | 200-300 | 0-5.47 | 0-7.18 | 0-6.31 |

Table 5.2: Ranges for manipulated variables

| Variable | XV1 | XV2 | XV3 | N | FCP3 |
|----------|-----|-----|-----|---------|---------|
| | - | - | - | - | J/(s K) |
| Range | 0-1 | 0-1 | 0-1 | 0.9-1.1 | 116-348 |

5.3.1. SISO Tuning

As a first simple tuning method, empirical tuning methods such as **Ziegler-Nichols** and **Cohen-Coon** were examined in tuning this system. However, the system dynamic responses cannot be approximated as first order with dead time responses, as the level responses are not self-regulatory, and the pressure responses are almost instantaneous, therefore, these methods could not be applied.

Secondly, the **root-locus** plots for all potential control loops were obtained. Figure 5.8 shows the results of root-locus analysis of the system obtained in MATLAB using the linear model. From the figure it is clear that applying a simple criterion such as the 4:1 decay ratio cannot obtain a unique tuning for each loop, as the individual loops are not oscillatory. The controller zero must be chosen to force

oscillation, then the controller gain can be determined.

Tuning the controllers using the **dominant pole cancelling** method is then performed (for full description, see D’Azzo and Houpis, 1995). Examining the poles in all selected loops (see Figure 5.8) shows that the dominant pole(s) lies on the origin, as a result, the nearest pole to the origin is the one to be cancelled by placing the controller zero on top of it. As can be seen from the figure, this method results in tuning in which identical integral times and maximum gains are used in all loops. The integral time used in all loops is 37.61 seconds. Table 5.3 shows the gain factors applied to all loops examined in the subsequent sections.

Table 5.3: Maximum allowable gain factors on potential control loops

| Loop | Gain factor | Gain Sign |
|-------------|--------------------|------------------|
| L1 – XV2 | 2.86 | +ve |
| L1 – N | 0.57 | -ve |
| L1 – XV3 | 2.86 | -ve |
| L1 – P1 | 5.71 | +ve |
| L1 – FL2 | 15.63 | +ve |
| L2 – XV3 | 10.0 | +ve |
| L2 – XV2 | 10.0 | -ve |
| L2 – FL3 | 70.18 | +ve |
| L3 – XV3 | 1.47 | -ve |
| L3 – P1 | 2.94 | -ve |
| P1 - N | 1.0 | -ve |
| P1 – XV2 | 5.0 | +ve |
| P2 – XV1 | 3.33 | -ve |
| P2 – FG2 | 21.03 | -ve |
| P3 – FCP3 | 386.67 | -ve |
| TP1o - N | 0.02 | -ve |
| TP1o – P1 | 0.20 | +ve |
| TP1o – XV2 | 0.10 | -ve |
| FL2 - XV2 | 15.63 | +ve |
| FL3 - XV3 | 70.18 | +ve |
| FG2 - XV1 | 21.03 | -ve |

An attempt to **optimise the ISE** of each individual loop was also performed. Figure 5.9 shows an example of the result of optimising the tuning for the P1-N loop. In most cases, the results obtained from this method hit the specified limits for both gains and integral times, as well as exceeding the limits on the manipulated variables when implemented as a single loop on the non-linear time domain model. Also, when closing all the five loops in the full scale non-linear models, the model came unstable with some of the tuning settings. As a result, this method was discarded.

5.3.2. Multi SISO Tuning

In multi SISO loop systems, as interaction affects the stability of the control system, the controller tuning must consider interaction as well as single-loop feedback dynamics. In general, interaction demands a reduction in the allowable values for the controller gains. Three main approaches are usually used to tune multi SISO loop controllers (Marlin, 1995):

1. **Trial and error:** this is the method often used in practice. Initial values used are the single-loop tuning. The final tuning must be conservative (i.e. not very close to the stability margins). This method is usually quick, and leads to good results if the interaction is not strong. In this system, this method was not adopted as it cannot lead to a systematic method of tuning all controllers.
2. **Optimisation:** in this method the tuning is determined by optimising the performance of a specific control objective, usually the ISE values of one or more controlled variables. This method requires extensive computations, and is justified only if interaction within the process is strong (Marlin, 1995).

Using Simulink, and the linear version of the model, attempts to tune the controllers simultaneously were performed. In these attempts, the five loops were all closed, their integral action factor was determined using the dominant pole cancelling method, and the controllers gains were determined by minimising the ISE of TP1o. The starting point for the optimisation process was chosen randomly each time, and the process continued until all five loops were tuned.

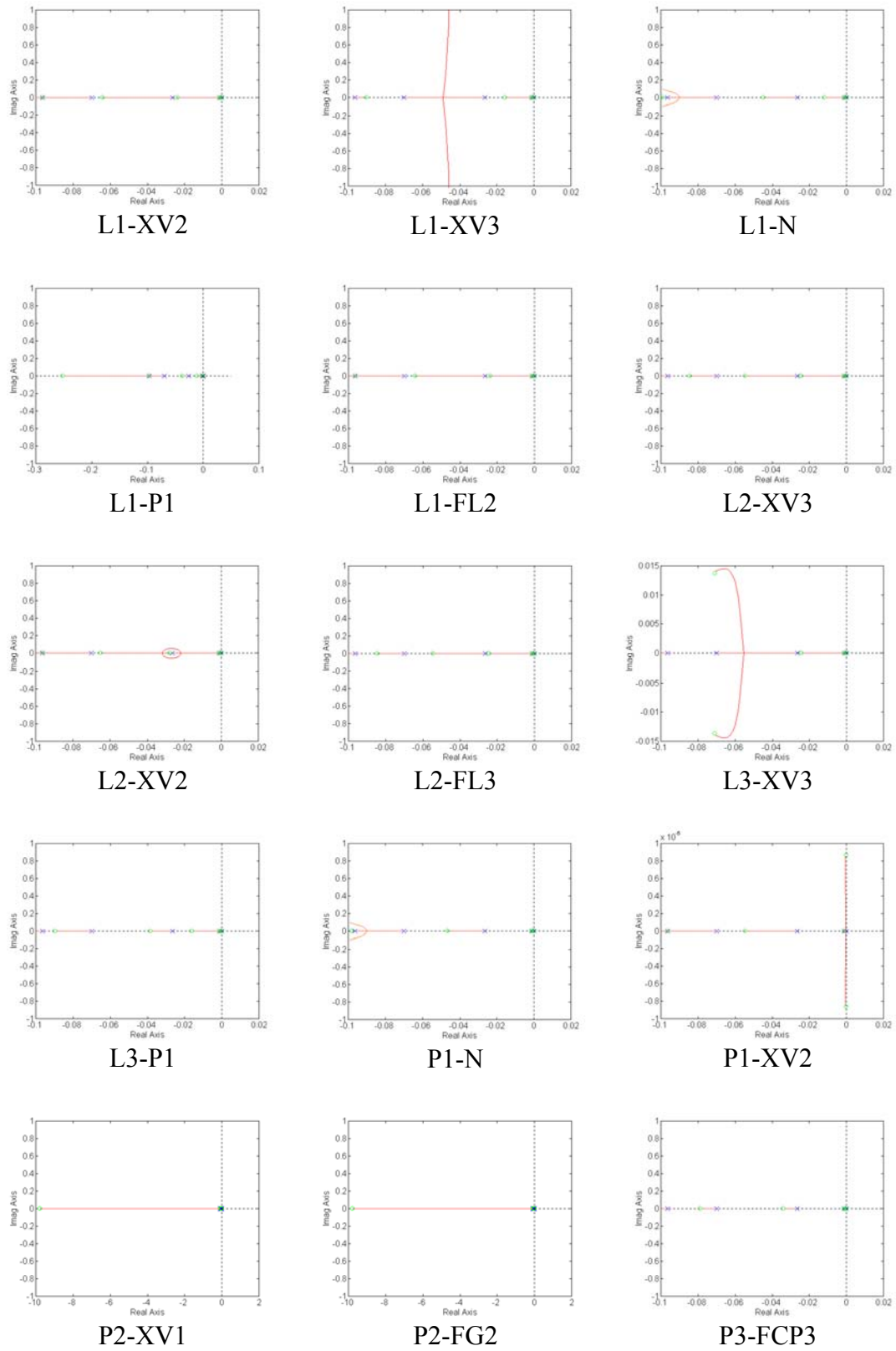

Figure 5.8: Root locus plots for the candidate control loops

contd.../

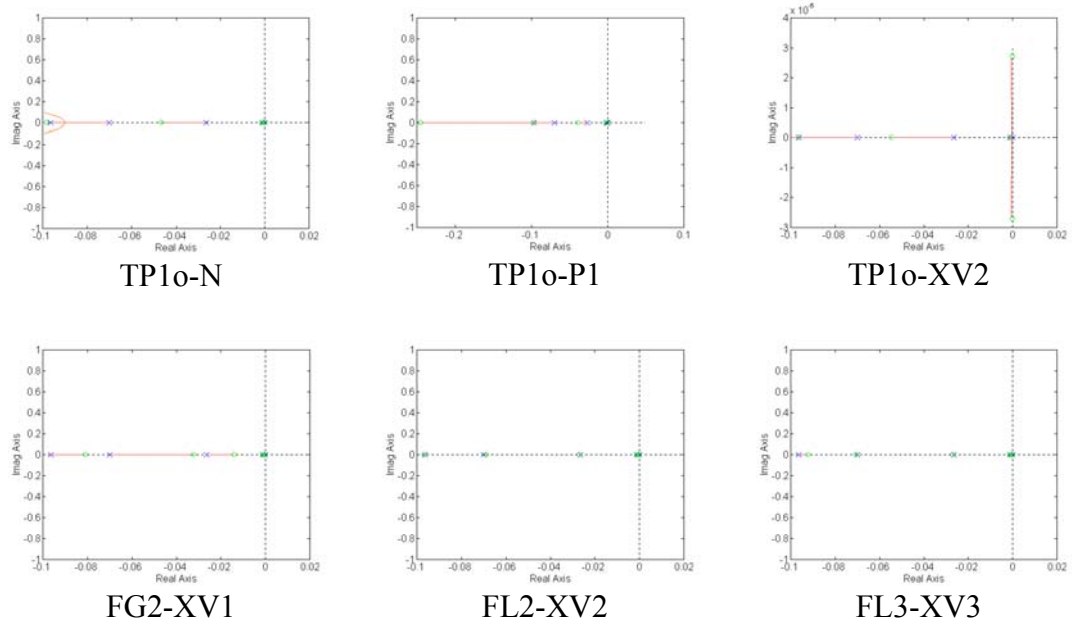
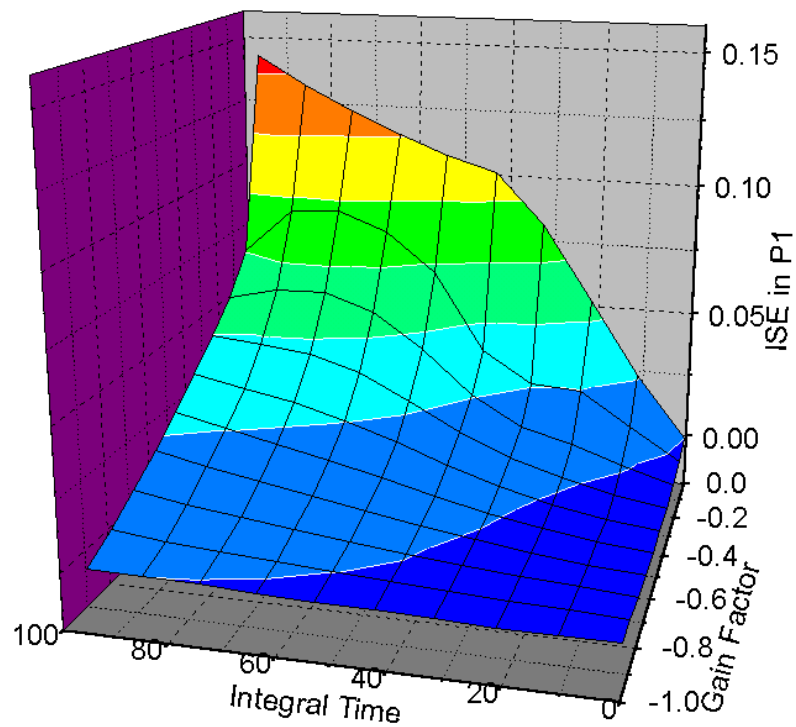
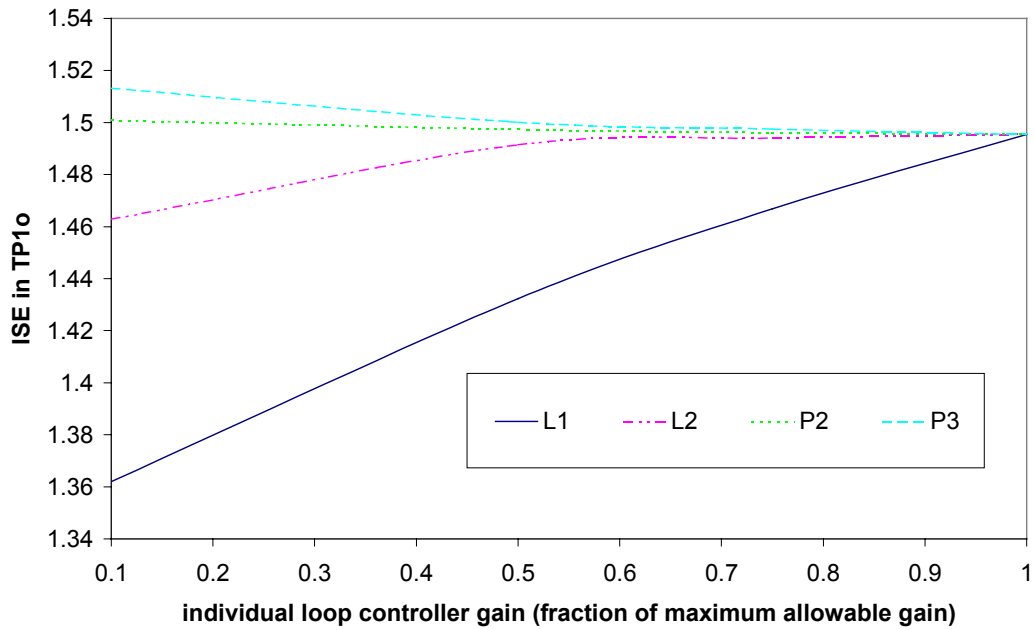

Figure 5.8 (Continued): Root locus plots for the candidate control loops



Integral time in seconds, gain factor in bar^{-1}
 Colours indicate ISE axis in eight equal divisions

Figure 5.9: Example of obtaining tuning parameters based on optimising individual control loops (P1-N loop)



(a) Variation of ISE values of TP1o for control of L1, L2, P2 and P3 (gain expressed as a fraction of its maximum value)

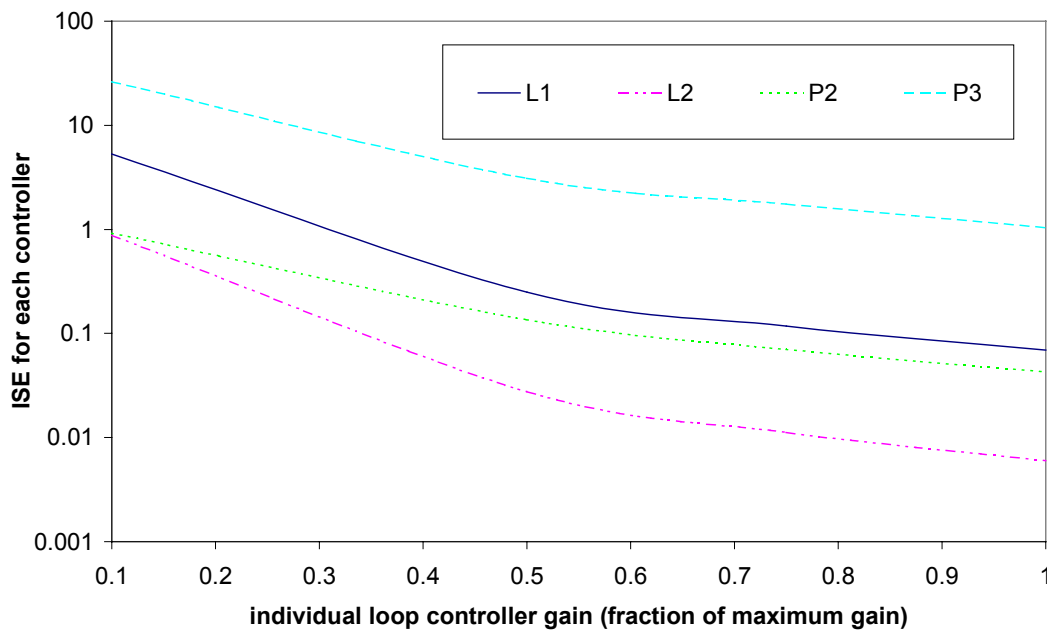

(b) Variation of ISE values for control of L1, L2, P2 and P3 (gain expressed as a fraction of its maximum value)

Figure 5.10: Loops Tuning based on optimisation of ISE in TP1o

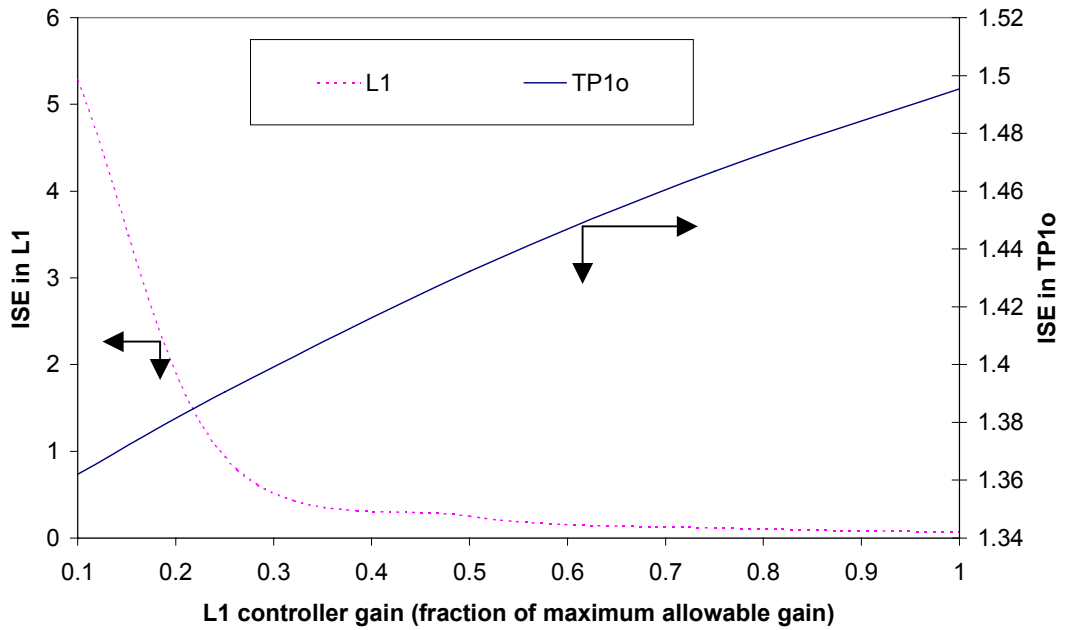

Figure 5.11: Effect of changing the gain of L1 loop on the ISE of L1 and TP1o (gain expressed as a fraction of its maximum value)

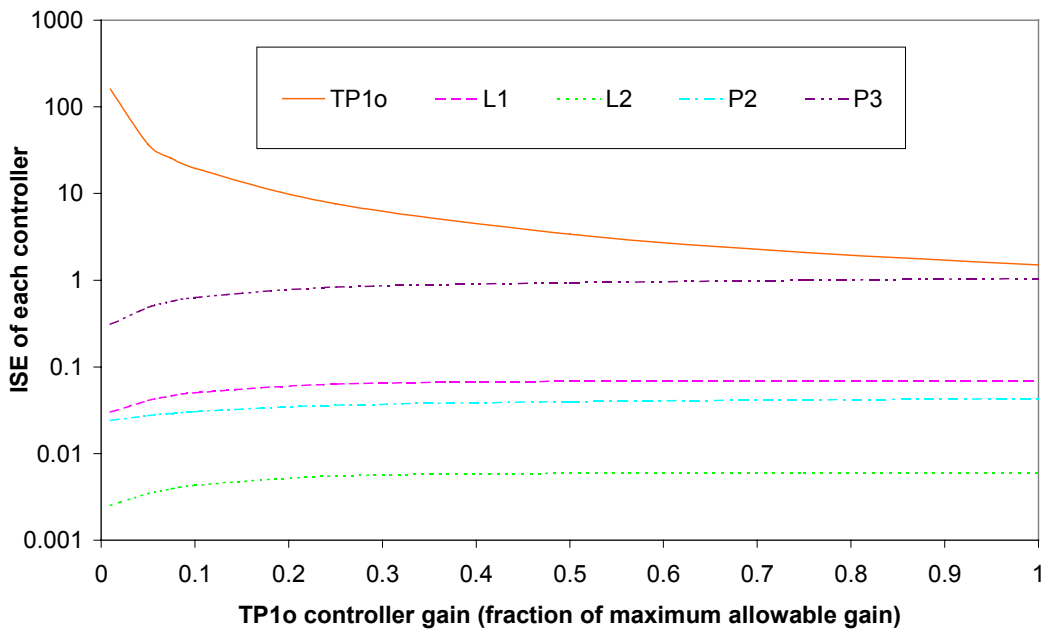

Figure 5.12: Variation of ISE of each control loop as a result of changing the TP1o gain factor (gain expressed as a fraction of its maximum value)

(gain expressed as a fraction of its maximum value)

The tuning obtained from this method, called for maximum gain to be used on pressure loops, a gain factor above 5 for L2, with virtually no difference in ISE values above that, and a minimum gain on L1 loop (see Table 5.3 for maximum gain values). However, applying these recommendations means that the oscillation in L1 will be large, and has no guarantee that the tubes in the LP evaporator will be submerged all the time, therefore, the tunings from this method were not adopted. Figure 5.10 shows the effects of changing the gain factor on 4 individual loops on the value of ISE of the individual loops and of TP1o. It is clear from the figure that although tightening the control settings for each individual loop improved its performance measured by its ISE, it led to the deterioration of the ISE of TP1o when the gain on both L1 and L2 was increased. The effect is small on L2 gain, but is relatively significant on L1. Figure 5.11 shows the values of ISE in L1 and TP1o against changing the gain on L1 from 10% to 100% of its allowable value. It can be seen clearly that an inverse relationship exists between the two. In fact, as shown in Figure 5.12, the main factor in reducing the ISE of TP1o is to tighten its own settings.

3. Analytical and non-iterative approaches: several methods were suggested in the literature (e.g. Ogunnaike and Ray (1994)) to estimate the multi-loop tuning analytically or approximately. These methods were mostly for 2×2 systems, involved a great amount of calculations, and were very difficult to extend to higher order systems. No general method has yet been found. In this study, these methods were not used to obtain systematic tuning.

5.4. DISTURBANCES

In examining the performance of the different configurations, a common disturbance was introduced in all cases. The disturbance is a step change of +2 K in the process stream input temperature in the LP evaporator TP1i.

In addition to that, two other disturbances were used examine the robustness of the temperature cascade control schemes:

1. A step change of -2 K in the process stream input temperature in the LP evaporator TP1i.
2. A step change of $+10$ K in the process stream input temperature in the IP evaporator TP2i.
3. A step change of -5 K in the cooling air input temperature TP3i to the condenser.

5.5. SIMULATION RESULTS

The performance of all different control cases is presented in this section. In presenting the results, a consistent method is used to allow for a wider comparison and better understanding of the results. In the text that follows, the term “potential” controlled variables refers to the variables controlled in any of the examined cases though not all are controlled in each case. This includes the levels in the evaporators L1 and L2, the level on the receiver L3, the pressures in both evaporators P1 and P2, the pressure in the condenser P3, and the process stream outlet temperature in the LP evaporator TP1o.

To verify the suitability of the controller tuning obtained earlier, the performance of the conventional Base Case is evaluated using two different settings: the tuning obtained from the dominant pole cancelling (DPC) method described in Section 5.3.1 and the tuning used by Dacey (1994). Figure 5.13 (page 95) shows the transient responses of the potential controlled variables, using both settings. From the figure, it is obvious that the DPC method yields better results compared to Dacey's method. The numerical values of the ISE of the variables are found in Table 5.4, and show clearly that the DPC tuning improves the performance of all the loops significantly between 6.3% to 97%. On the other hand, there is no improvement in the TP1o response where an offset is sustained. It should be noted, however, that this temperature is not controlled here directly.

The control schemes described in Section 5.2 were all applied to the system under all control approaches. Table 5.5 shows the ISE results of the potential controlled variables.

Table 5.4: ISE values of controlled variables in conventional control approach, Base Case, using DPC. and Dacey's tuning settings

| Case | L1 | L2 | P1 | P2 | P3 |
|--------------|---------|---------|---------|---------|---------|
| DPC | 0.02674 | 0.00224 | 0.00568 | 0.02296 | 0.25858 |
| Dacey | 0.19303 | 0.07531 | 0.00606 | 1.02048 | 2.09331 |
| Ratio | 0.139 | 0.030 | 0.937 | 0.022 | 0.124 |

Table 5.5: ISE values of controlled variables in all cases applying the three control approaches^(*)

| Case | TP1o | L1 | L2 | L3 | P1 | P2 | P3 |
|---|--------------|-----------|-----------|--------------|--------------|---------|---------|
| Conventional Control Approach | | | | | | | |
| Base | (∞) | 0.02674 | 0.00224 | (0.09471) | 0.00568 | 0.02296 | 0.25858 |
| L1/L3 | (∞) | 0.02698 | (0.00298) | 0.08590 | 0.00564 | 0.01860 | 0.25363 |
| L2/L3 | (∞) | (0.05469) | 0.00235 | 0.08171 | 0.00441 | 0.01763 | 0.24861 |
| C/Liq | (∞) | 0.01489 | 0.00182 | (0.06047) | 0.00583 | 0.02238 | 0.26443 |
| C/Vap | (∞) | 0.02720 | 0.00223 | (0.09550) | 0.00566 | 0.00236 | 0.25859 |
| Direct Temperature Control Approach | | | | | | | |
| Base | 34.8659 | 0.03781 | 0.00314 | (∞) | (∞) | 0.02605 | 0.46471 |
| L1/L3 | 34.7328 | 0.03828 | (0.03917) | 0.12281 | (∞) | 0.02009 | 0.45689 |
| L2/L3 | 34.1677 | (0.11251) | 0.00329 | 0.11251 | (∞) | 0.01873 | 0.44725 |
| C/Liq | 35.1567 | 0.02118 | 0.00253 | (∞) | (∞) | 0.02520 | 0.46852 |
| C/Vap | 34.8253 | 0.03831 | 0.00313 | (∞) | (∞) | 0.00317 | 0.46433 |
| Cascade Temperature Control Approach | | | | | | | |
| Base | 1.49541 | 0.06904 | 0.00599 | (∞) | (∞) | 0.04281 | 1.03994 |
| L1/L3 | 1.49395 | 0.06929 | (0.05495) | 0.21645 | (∞) | 0.02919 | 1.00588 |
| L2/L3 | 1.44514 | (0.19030) | 0.00562 | 0.19803 | (∞) | 0.02542 | 0.96007 |
| C/Liq | 1.52533 | 0.04262 | 0.00515 | (∞) | (∞) | 0.04203 | 1.07433 |
| C/Vap | 1.49213 | 0.06969 | 0.00601 | (∞) | (∞) | 0.00579 | 1.02889 |

^{*} *Italic numbers in brackets indicate variables which are not under direct control*

It should be noted that in the control loops, the ISE values are calculated reference to the set points. For the uncontrolled variables, the ISE values are calculated reference to the error from the steady state values of the Base Case with no disturbances, which are treated as set points for the calculation purposes. In cases where the response results in an offset, the ISE value is ∞ .

As can be seen from Table 5.5, the ISE values of TP1o are distinguishable between the control approaches used. The differences are very high between the corresponding cases in each approach. However, the differences in the ISE values of TP1o between the different cases within each approach are very small, and are all within a range of 5.3%. This makes the comparison between the different cases difficult, and calls to include other factors in the comparison process. This is discussed in Section 5.5.2.

Based on the obvious distinction on ISE values between the three approaches, it is clear that the favourable control approach is the cascade temperature control approach. The explanation for this is fairly straightforward. In the conventional approach, the process stream outlet temperature TP1o is not controlled directly, rather its value is determined indirectly via the level L1 and the pressure P1 controllers. This strategy maintains an offset in the final response of the temperature (unless there is operator intervention), which is translated into an infinity ISE value. When the temperature TP1o is controlled directly, the temperature is forced to go back to the set point by the integral action of the temperature controller, thus the ISE value is reduced significantly.

Using the cascade temperature approach achieved a 95.7% improvement in the ISE of TP1o relative to the direct temperature approach. In this approach, the cascade arrangement performed very successfully. The pressure (slave) control loop in this arrangement has faster dynamics than the temperature control loop; as a result, any disturbance that affects the system is detected first by the pressure measurement, which starts its corrective response immediately. The corrective action from the temperature controller then adjusts the set point of the pressure controller to bring the temperature back to its set point as desired.

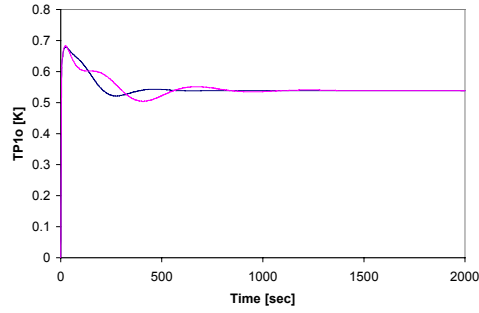

(a) TP1o perturbation

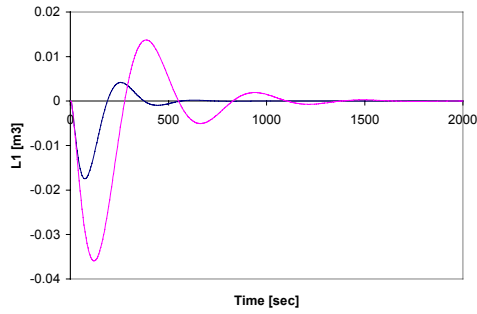

(b) L1 perturbation

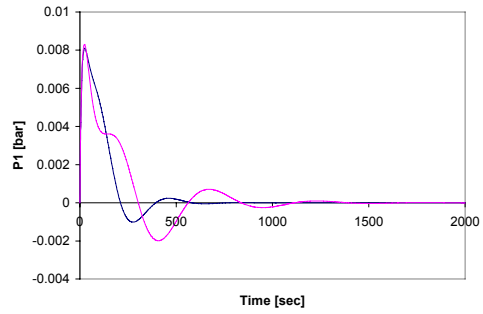

(c) P1 perturbation

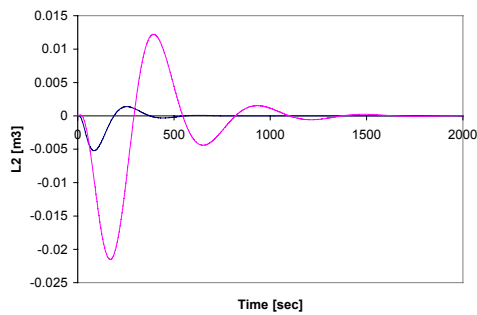

(d) L2 perturbation

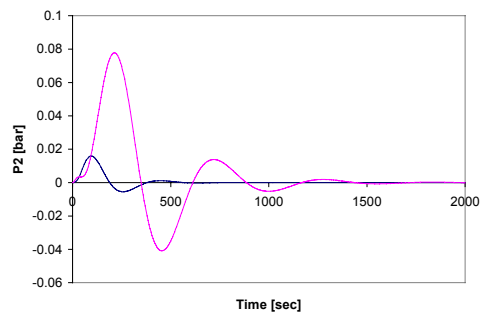

(e) P2 perturbation

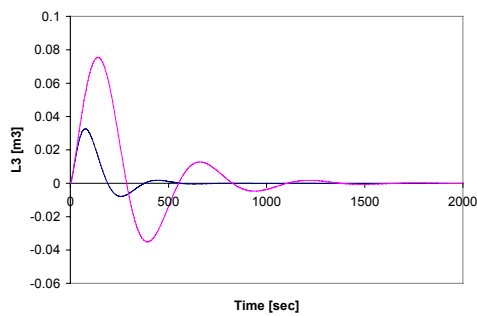

(f) L3 perturbation

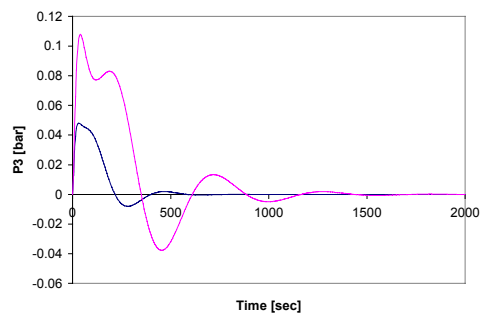

(g) P3 perturbation

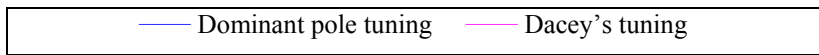
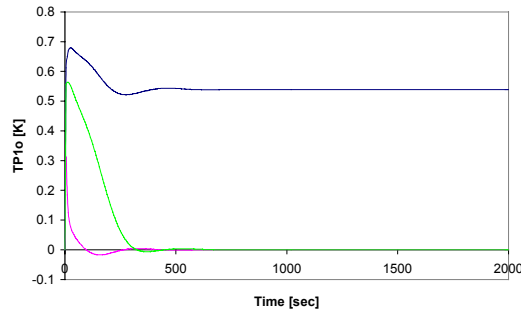
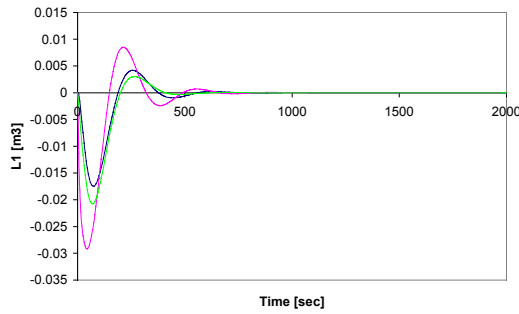

Figure 5.13: Performance of the two-stage refrigeration system with the conventional approach using dominant pole tuning and Dacey's tuning



(a) TP1o perturbation



(b) L1 perturbation

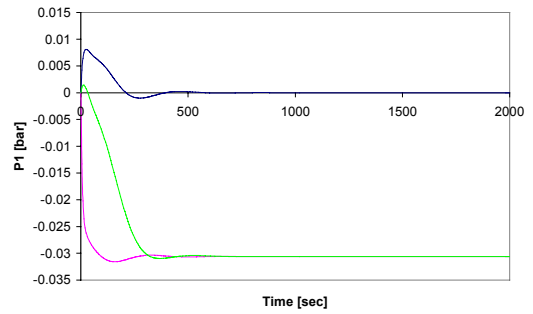

(c) P1 perturbation

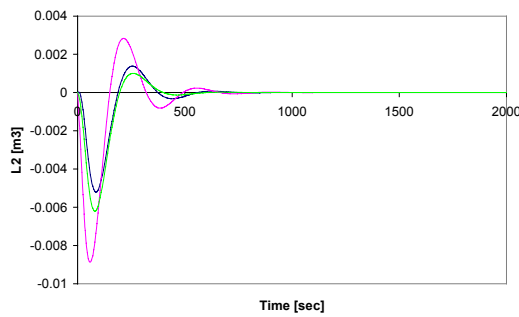

(d) L2 perturbation

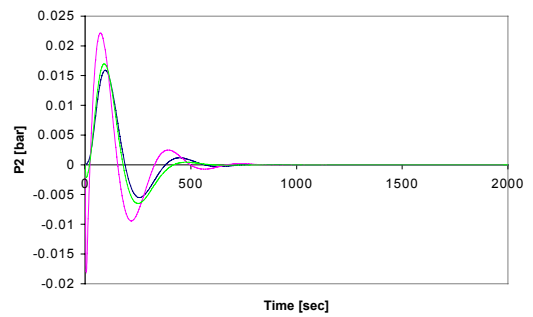

(e) P2 perturbation

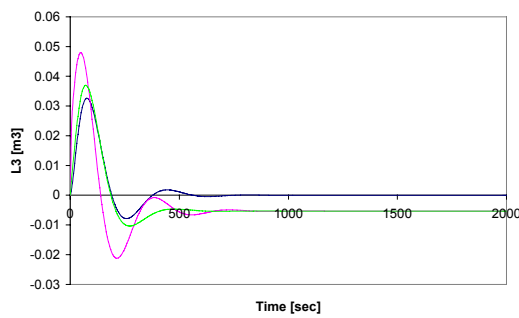

(f) L3 perturbation

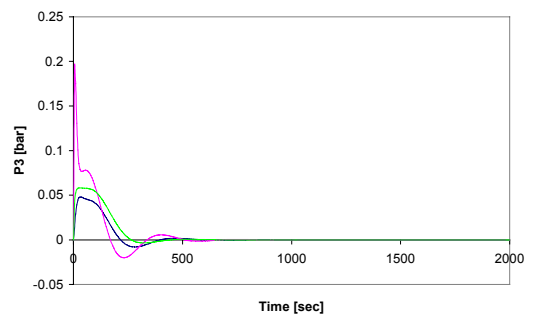

(g) P3 perturbation

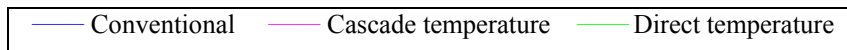

Figure 5.14: Performance of the two-stage refrigeration system comparing the conventional, cascade temperature and direct temperature control approaches

Figure 5.14 shows the transient responses of the potential controlled variables for the Base Case under the three different approaches. Note that the LP pressure P1 is not controlled applying the direct temperature approach, but still, its transient response is very similar to the controlled pressure in the cascade temperature approach, and both reach the same steady state. This further illustrates that the role played by the pressure controller is only enhancing the temperature controller by speeding its response, thus reducing its ISE value. This behaviour is obvious looking at the temperature TP1o response in Figure 5.14, where it is clear that the transient response is faster in the cascade temperature control approach and the temperature takes less time to reach its set point.

Based on ISE values of TP1o, the results above showed clearly that the cascade temperature control approach is favourable. It should be noted however, that this is achieved at the expense of all other loops whose performance is the best in the conventional approach. This performance is worse in the direct temperature approach, and deteriorates further in the cascade temperature approach. However, the values of the ISE for the other controlled variables are all smaller compared to the ISE value of TP1o, and the relative change in their values, although it seems big, is insignificant when compared to the improvement achieved in the temperature control.

5.5.1. Performance Comparison of Different Cases with Cascade Temperature Control Approach

As a result of the above recommendation, it is only necessary to examine the performance of different cases under the temperature cascade approach. However, for comparison purposes, the results of the different cases under both other approaches were also reported. The ISE results are shown in Table 5.5.

Case L2/L3 shows the best ISE value in TP1o. It shows an improvement of 3.4% compared to the cascade temperature approach Base Case. It should be noted that in this case the level in the LP evaporator L1 is not controlled, but it reaches its steady state level as a result of other controlled variables reaching their steady state. In some cases this may be undesirable, as it cannot be guaranteed that the transient

level response does not fall below the minimum level accepted. The improvement in the ISE value of TP1o in this case agrees with the behaviour observed when the multi SISO optimal tuning was attempted, where the smaller the gain on the level L1 controller, the better (i.e. the smaller) the ISE value of TP1o is.

Another improvement in the ISE value for TP1o is observed in Case L1/L3 under cascade temperature approach. The improvement is negligible (0.1%) compared to the improvement in Case L2/L3. This is due to the fact that most of the refrigerant inventory is under direct control in this case, as L3 and L1 are both controlled, which means that the transients in the levels respond faster, and hence result in smaller ISE values. However, in this case, the liquid level in the IP evaporator is also uncontrolled, and this cannot guarantee that its transient will not fall below the minimum level under some conditions.

In both cases, the control of P2 is also improved, where ISE values decrease by 40.6% and 31.8% respectively. This is due to the fact that controlling L3 minimises disturbance effects to P2 thus improving its performance.

Earlier studies performed on this system (Dacey, 1994; Asmar *et al.*, 1998a) suggested that using cascade liquid flowrate controllers in controlling the levels in both evaporators results in improvement to the ISE value of TP1o. In both studies, the tuning used was similar. In this study, the cascade liquid flow arrangement does not show any improvement in terms of ISE value of the process temperature TP1o. On the contrary, it deteriorates by 2%. However significant improvement is achieved in controlling L1 and L2 with ISE values decreasing by 38.3% and 14.0% respectively, which is expected. Figure 5.15 shows that the responses of the two cases lie almost on top of each other. The difference between the two cases is even less in the other two approaches. The behaviour can be explained as the dynamic responses of the flowrates are much faster than the levels, the flow measurements will sense the disturbance first, and thus the flow controllers will start a corrective action. The level controllers will then set new set points for the flow controllers once they sense the disturbance.

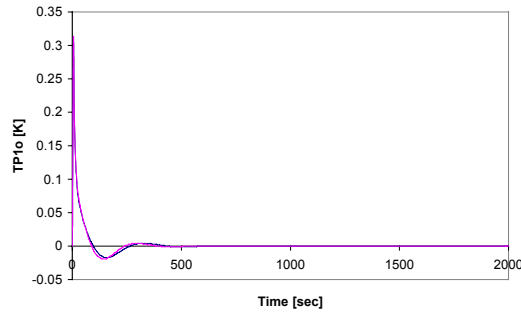

(a) TP1o perturbation

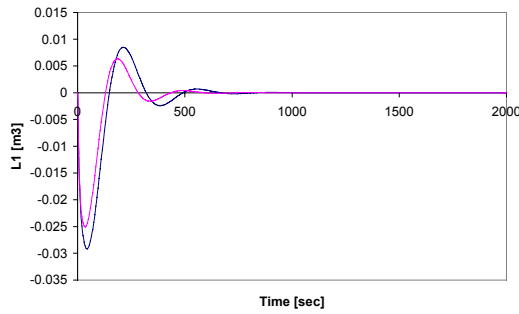

(b) L1 perturbation

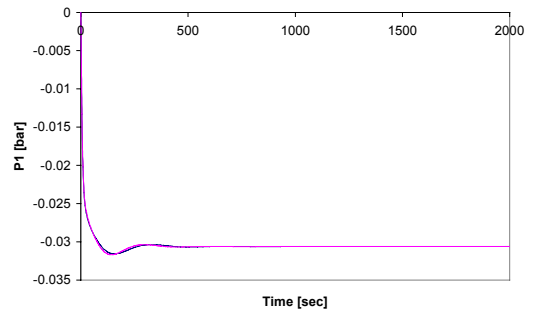

(c) P1 perturbation

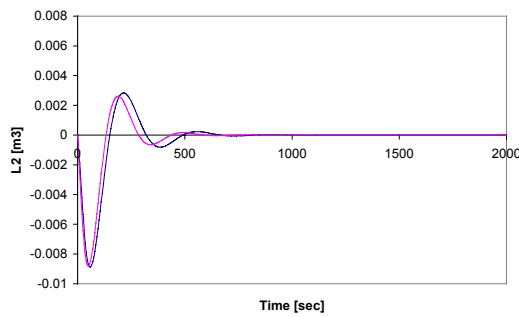

(d) L2 perturbation

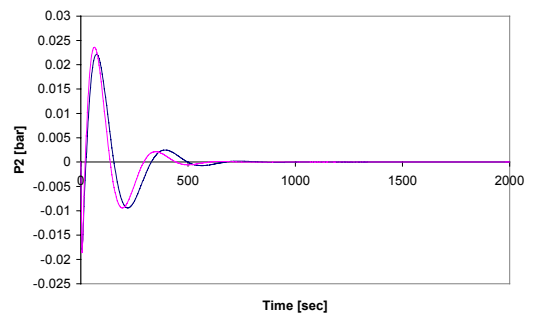

(e) P2 perturbation

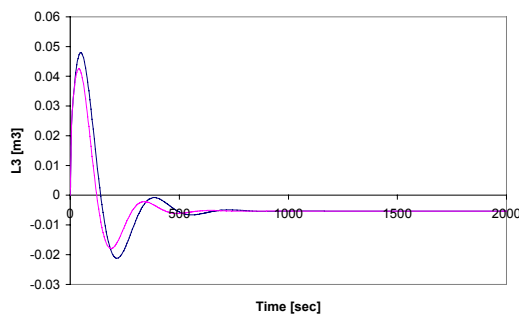

(f) L3 perturbation

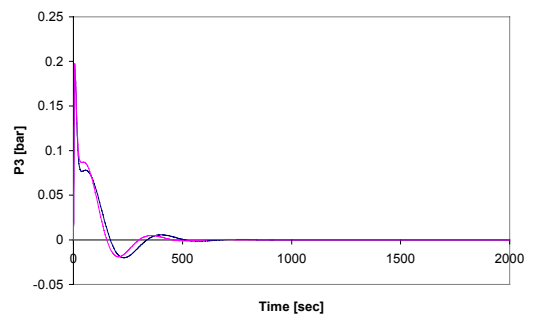

(g) P3 perturbation

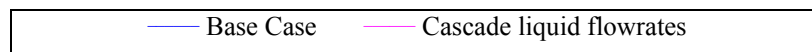

Figure 5.15: Performance of the two-stage refrigeration system with the cascade temperature control approach using Base 5-loop Case and cascade liquid flowrates

However, since in this case, tight control for the level L1 increases the values of ISE of TP1o, this approach will increase the ISE value as a result of L1 controller. The improvement in ISE value of TP1o due to better L2 control is made negligible by the undesirable effect of the L1 controller.

The performance of the Cascade Vapour Flow Case shows negligible change concerning the ISE value of TP1o compared to the cascade temperature Base Case. The change is 0.2%, and is almost the same magnitude in both other approaches. The only loop that improves in this case is the P2 loop itself, where it improves by 86.5%, which is completely expected. This illustrates that the cascade arrangement makes no difference in this case in this application as no enhancement can be seen. This is explained as the relative speeds of the dynamic responses of the pressure and the vapour flow do not differ significantly. In this case, the additional flow measurement does not cause the system to react faster as the pressure measurement senses the same effect at the same time or even faster. Consequently, the additional flow loop will add only extra costs to the control system, and can be rejected as a possible scheme.

5.5.2. Performance Comparison Using Weighted-Performance Functions

It can be seen that comparing the performance of the five feasible cases using cascade temperature control is very difficult based on ISE values of TP1o. The values are very close to each other within a range of less than 2%. Although this may be enough, it was decided to include more control loops in the comparison procedure. Two weight functions are proposed. In these functions the ISE of TP1o is given a 50% weight, while other loops included in the function comprise the other 50%.

The general form of the weight functions proposed is defined as:

$$PF = \frac{ISE_r^{TP1o}}{2} + \frac{\sum_1^m ISE_r^{wcv}}{2m} \quad (5.2)$$

where PF is the performance factor, wcv is the weighted controlled variable, m is the

number of controlled variables included, and ISE_r is the normalised integral square error, which is defined as:

$$ISE_r = \frac{ISE \text{ (any case)}}{ISE \text{ (Base Case)}} \quad (5.3)$$

The performance factor PF gives in reality the ratio of the ISE values of the desired controlled loop for each case to the their Base Case values. Any value below one indicates improvement, and any value above one means deterioration in the performance.

The first weight function proposed includes the performance of the two levels controlled. These levels are L1 and L2, L1 and L3 or L2 and L3 depending on the case examined. Thus each level is given effectively 25% of the weight in the performance factor.

The second weight function includes the performance of all the five control loops, each given an equal weight, and all combined add up to 50% of the weight of the performance factor.

Table 5.6 shows the results of the comparison based on comparing ISE of TP1o only, and based on the performance factors of the weight functions.

Table 5.6: Comparison of the control cases performance based on several performance factors

| Case | TP1o | 2 level loops | All loops |
|--------------|-------------|----------------------|------------------|
| Base | 1.0000 | 1.0000 | 1.0000 |
| L1/L3 | 0.9990 | 0.9647 | 0.9383 |
| L2/L3 | 0.9664 | 0.9139 | 0.8882 |
| C/Liq | 1.0200 | 0.8796 | 0.9467 |
| C/Vap | 0.9978 | 1.0024 | 0.8912 |

The comparison based on the weight function gives a clearer picture of the

improvement or deterioration of the system performance. For example, the performance improvement of 3.4% of Case L2/L3, is 8.6% when the two levels are included, and 11.2% when all loops are included. In Cases L1/L3 and L2/L3, the weight factors reached the same conclusions reached based on comparing ISE of TP1o only, but with bigger margins thus clearing the picture.

In the cascade flow cases, the picture changed depending on the performance factor used. When TP1o and the two levels controlled were included, Case C/Liq came the best performing, and with all loops included it still performed better than the Base Case but worse than the other 3 cases. In Case C/Vap, the opposite happens, it performs slightly worse when only two levels are included in the performance factor, but it is the second best when all loops are included.

5.6. REDUCED CONTROL LOOPS

An investigation to examine the effect of leaving some control loops on manual is performed. In this system, the two level control loops are essential in all cases to prevent the levels from filling or emptying the vessels completely. In addition to that, the cascade temperature control arrangement does not permit the opening of the pressure loop. As a result only two control loops, namely the intermediate pressure P2 and the high pressure P3 can be placed on manual.

Table 5.7: ISE values of potential controlled variables in cascade temperature control approach, basic case with reduced number of closed loops ^(*)

| Case | TP1o | L1 | L2 | P1 | P2 | P3 |
|-------------|---------|---------|---------|---------|---------|---------|
| Base | 1.49541 | 0.06904 | 0.00599 | 0.06339 | 0.04281 | 1.03994 |
| 4-P2 | 1.50051 | 0.06783 | 0.00554 | 0.06421 | (∞) | 0.99972 |
| 4-P3 | 1.52272 | 0.06873 | 0.00457 | 0.06618 | 0.05836 | (∞) |
| 3 | 1.52721 | 0.06675 | 0.00426 | 0.06710 | (∞) | (∞) |

^{*} *Italic numbers in brackets indicate variables which are not under direct control*

The interaction analysis confirmed that not controlling either P2 and /or P3 loops will reduce interaction (Asmar *at al.*, 1997). The investigation was carried on in the

form of three different cases: Case 4-P2 in which P2 control loop is open, Case 4-P3 in which P3 control loop is open, and Case 3 in which both P2 and P3 control loops are open simultaneously. The results of the ISE values of all arrangements are shown in Table 5.7.

The effect of opening the P2 loop resulted in a slight deterioration (0.3%) in the ISE value of TP1o. This was in addition to a slight deterioration in P1 control performance, but a better performance for the two levels and the P3 control loops. The effect of opening the P3 loop was in the same direction of all controlled loops in the system, with a deterioration of 1.8% in the ISE of TP1o.

Opening both loops simultaneously resulted in a repeat of the performance observed when either P2 or P3 was placed on manual. The improvement or deterioration was higher compared to the cases of only one loop open. Thus, the deterioration in the ISE of TP1o was 2.1%. The reason for that is as the responses of both changes are in the same direction, the effect of opening both loops results in an additive effect.

Figure 5.16 shows the transient responses of the potential controlled variables. As can be seen, the differences are insignificant in the closed control loops. However the differences are obvious in the uncontrolled variables which, as you would expect, settle at different steady states. The process temperature TP2o for fluid exiting the IP vessel tubes settles at different steady state values following the described step change disturbance. This is a direct consequence of the uncontrolled intermediate pressure P2, which if not controlled floats on the compressor inter-stage pressure. But since the high pressure P3 settles at different values whether it is controlled or not, the intermediate pressure P2 will reach different steady state, settling on higher values when P3 is not controlled. This difference is insignificant in cases where a single process stream passes through the tubes of both the LP and IP evaporators in series, where only the final process temperature is of importance. However, in cases which involve an independent secondary process stream, this deviation may be undesirable.

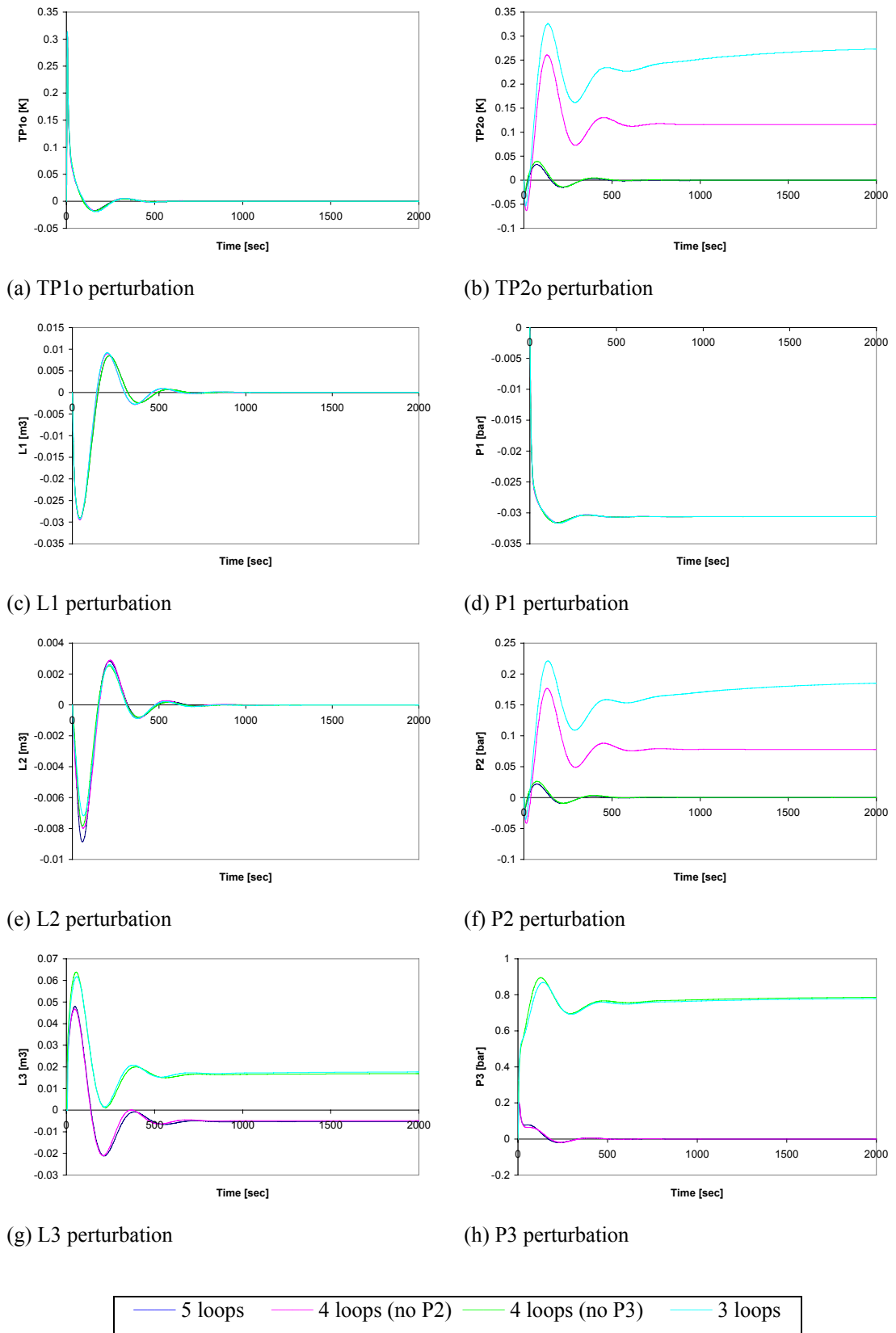

Figure 5.16: Performance of the two-stage refrigeration system with the cascade temperature control approach, but with a reduced number of control loops

5.7. ROBUSTNESS OF THE CONTROL SCHEME

To assess the robustness of the cascade temperature approach, three different disturbances were examined. These disturbances were previously explained in Section 5.5. The ISE results for the potential controlled variables are shown in Table 5.8, and the transient responses of these variables are shown in Figures 5.17 – 5.19

As can be seen from Table 5.8, the control system is robust as it can perform satisfactorily against the introduced disturbances. The severest disturbance is in the process stream temperature TP1i. This is expected as this change will directly affect the outlet process stream temperature TP1o. However, a reduction in the inlet temperature has a smaller disturbance effect compared to the same disturbance in the reverse direction.

A disturbance in the process stream temperature TP2i has very minor effect on the performance of the system. The reason is the relatively small size of the second evaporator and thus its heat load. Consequently, its effects are minor in the process.

A disturbance in the temperature of air coolant has also negligible effects on the outlet process stream temperature control. The only variable that it has a significant effect on is the condenser pressure, but its control is still acceptable.

Table 5.8: ISE values of all potential controlled variables in cascade temperature control approach, basic case, with different disturbances

| Disturbance | TP1o | L1 | L2 | P1 | P2 | P3 |
|--------------------|-------------|-----------|-----------|-----------|-----------|-----------|
| +2K TP1i | 1.49541 | 0.06904 | 0.00599 | 0.06339 | 0.04281 | 1.03994 |
| -2K TP1i | 1.33507 | 0.06875 | 0.00595 | 0.04972 | 0.04197 | 0.96368 |
| +10K TP2i | 0.00062 | 0.00001 | 0.00016 | 0.00007 | 0.01394 | 0.01699 |
| -5K TP3i | 0.01239 | 0.00003 | 0.00002 | 0.00004 | 0.00152 | 2.27137 |

Figure 5.20 is a repetition of some responses in Figure 5.17 with a lower gain factor (0.02) on TP1o-P1 loop to illustrate clearly the non-linearity of the system as an identical disturbance in both directions did not result in identically opposite transient responses in the responses of TP1o and P3.

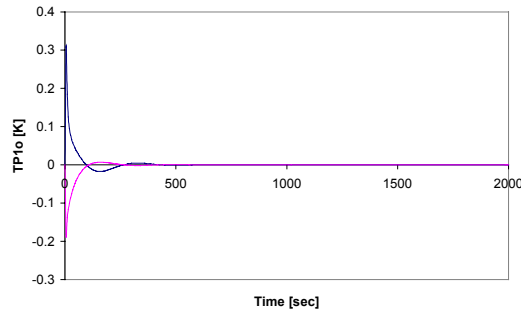

(a) TP1o perturbation

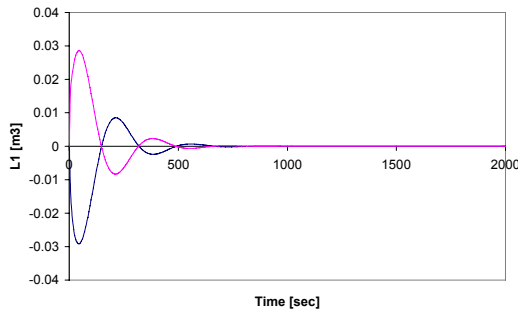

(b) L1 perturbation

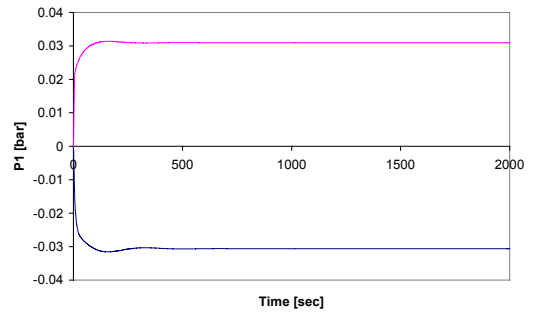

(c) P1 perturbation

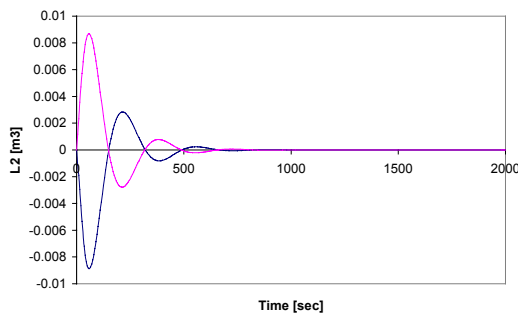

(d) L2 perturbation

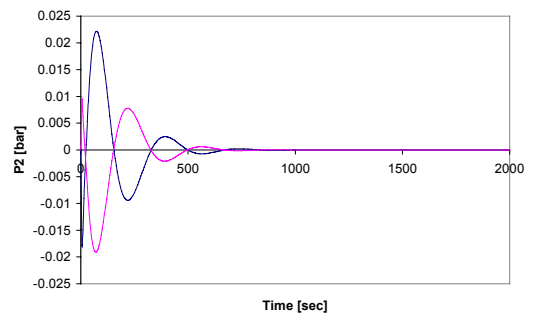

(e) P2 perturbation

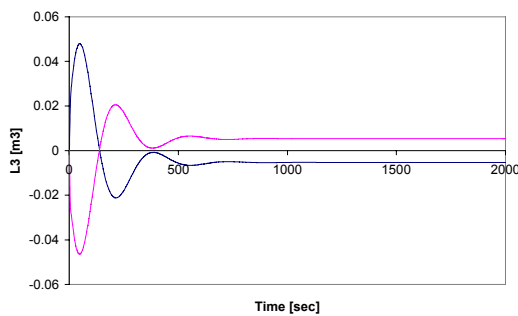

(f) L3 perturbation

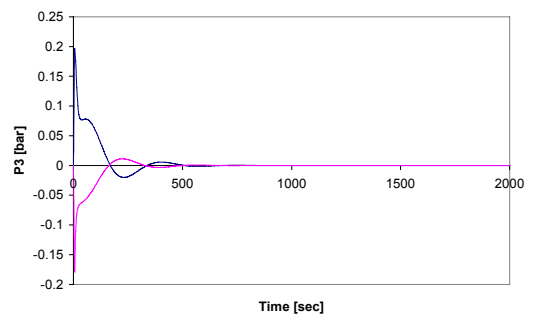

(g) P3 perturbation

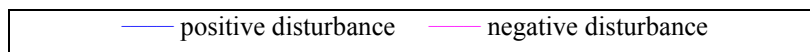

Figure 5.17: Performance of the two-stage refrigeration system with the cascade temperature control approach with positive and negative step change of 2 K in $TP1i$

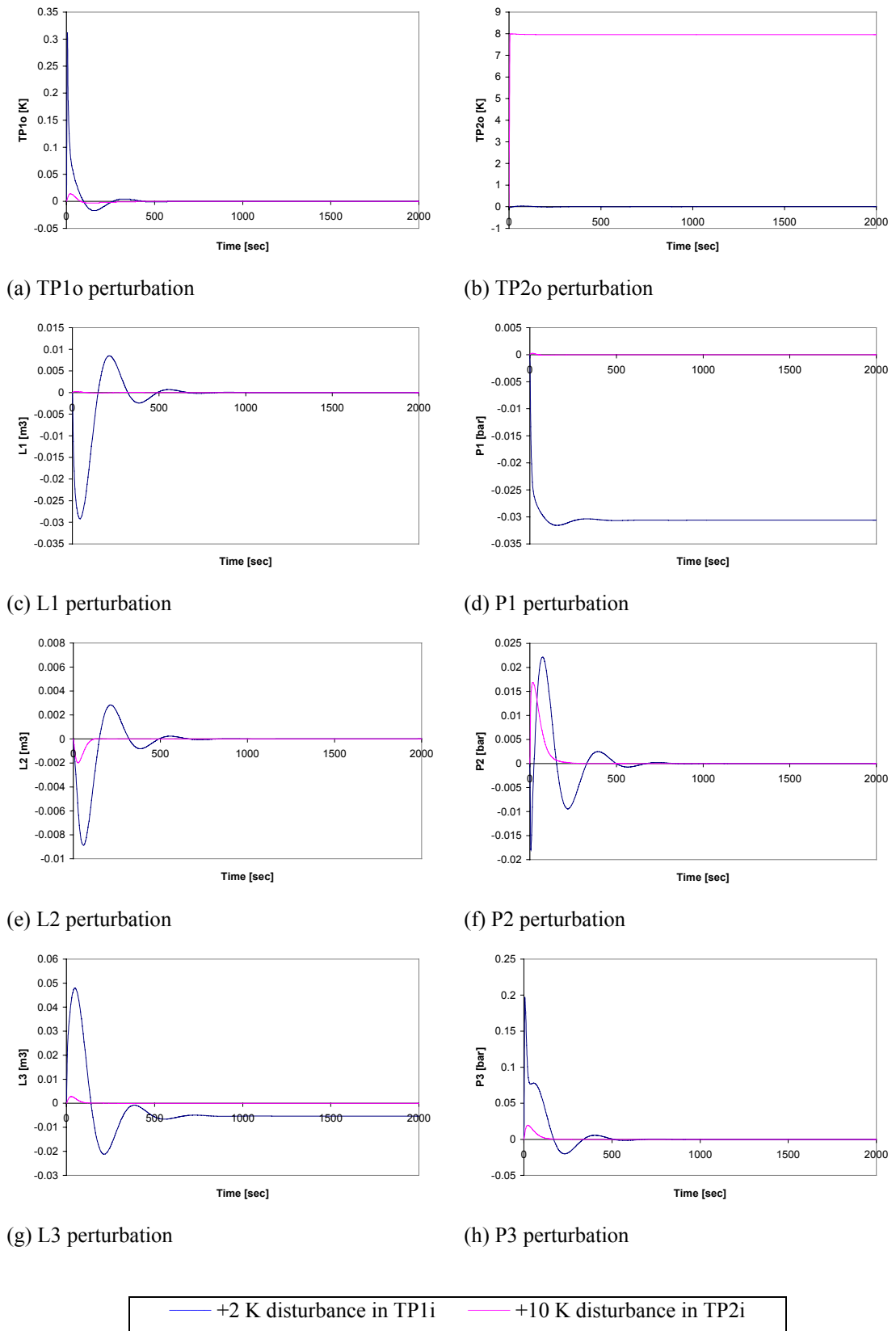
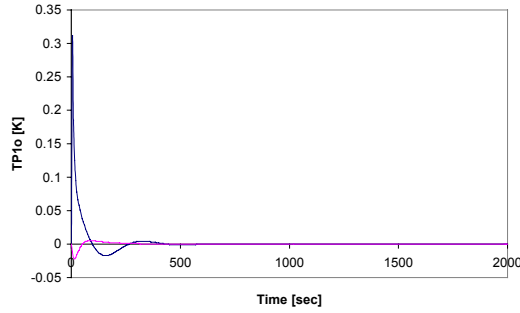
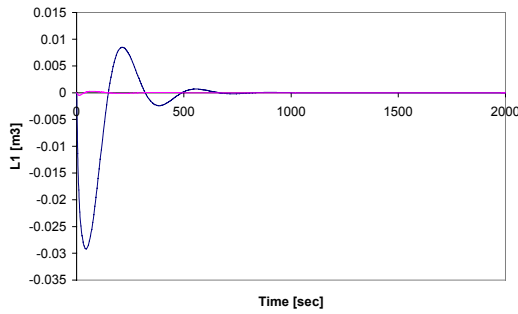

Figure 5.18: Performance of the two-stage refrigeration system with the cascade temperature control approach with disturbances in TP1_i and TP2_i



(a) TP1o perturbation



(b) L1 perturbation

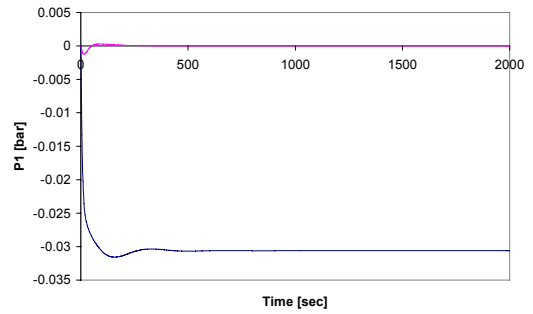

(c) P1 perturbation

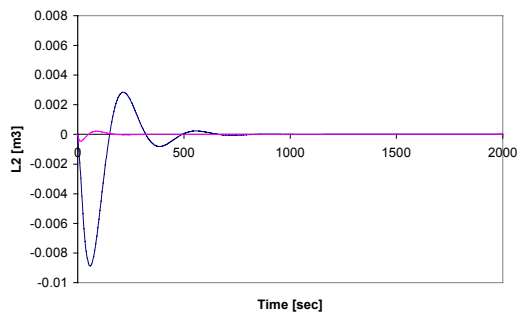

(d) L2 perturbation

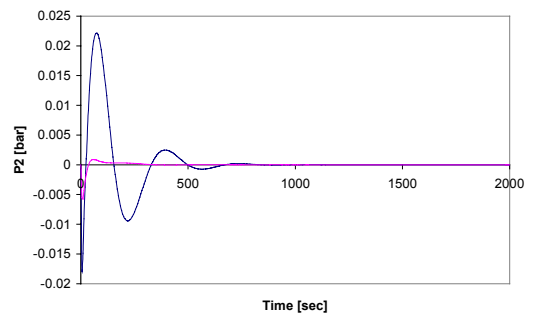

(e) P2 perturbation

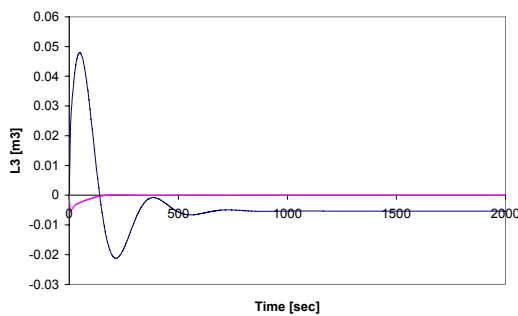

(f) L3 perturbation

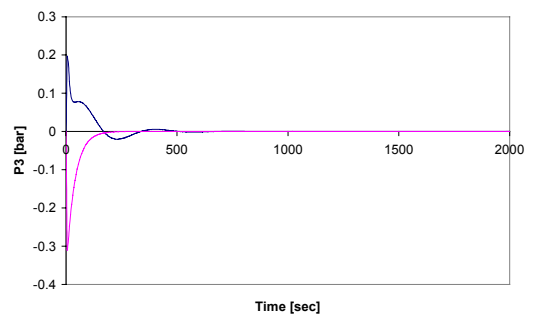

(g) P3 perturbation

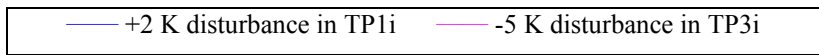
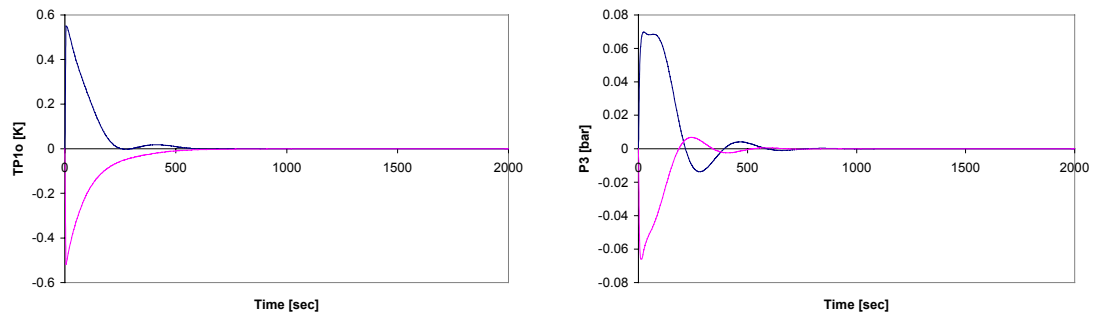

Figure 5.19: Performance of the two-stage refrigeration system with the cascade temperature control approach with disturbances in TP1i and TP3i



(a) TP1o perturbation

(b) P3 perturbation

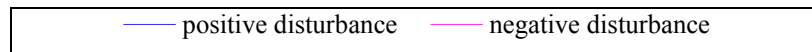

Figure 5.20: Non-linear effects in the two-stage refrigeration system with the cascade temperature control approach with positive and negative step change of 2 K in TP1i, gain factor on TP1o-P1 loop = 0.02

5.8. DISCUSSION

In this chapter, the controlled performance of the two-stage refrigeration system was investigated. With five degrees of freedom available for control and seven candidate control variables, heuristics were used to determine three major control approaches, and several cases within each approach were tested. The comparison between cases was based on introducing disturbances in the process stream inlet temperature to the LP evaporator TP1i, and assessing the ISE of the response in the process stream outlet temperature TP1o as a performance criterion. The main conclusions drawn are as follows:

- The process stream outlet temperature TP1o must be directly controlled to achieve acceptable performance.
- Two level control loops must be used to guarantee the system stability against disturbances
- Tuning the five control loops to minimise the ISE in TP1o is an awkward task, as it requires significantly relaxing the control of the level loops, which may lead to unacceptable transients in the levels response, so a compromise is essential. This illustrates clearly the interactive nature of the process.

-
- Improving the control of TP1o results in slight deterioration in the performance of other control loops.
 - The cascade temperature control approach performs significantly better than the both the conventional and the direct temperature approaches in terms of the ISE of TP1o, although the performance of the other control loops deteriorates slightly.
 - The inclusion of L3 as a controlled variable instead of L1 or L2 improves the performance of the process, with the best performance if L1 is excluded. However, this cannot guarantee effective heat transfer in the evaporators.
 - Using cascade liquid flow or cascade vapour flow arrangements does not result in any significant performance improvement based on the ISE of TP1o. However if the performance criterion included 50% weight to the other 4 loops controlled, significant improvement is achieved.
 - Reducing the number of control loops to three by eliminating P2 or P3 results in slight deterioration in the process performance based on ISE in TP1o. However, the performance of the level loops improves.
 - The cascade temperature control system is robust as it performs well in response to different disturbances. Its non-linear nature is evident by the non-identical response to an equal disturbance in TP1i in positive and negative terms.