



Profitable and dynamically feasible operating point selection for constrained processes



M. Nabil^a, Sridharakumar Narasimhan^{a,*}, Sigurd Skogestad^b

^a Indian Institute of Technology Madras, Chennai 600036, India

^b Norwegian University of Science and Technology, Trondheim, Norway

ARTICLE INFO

Article history:

Received 6 July 2013

Received in revised form 4 February 2014

Accepted 11 February 2014

Available online 1 April 2014

Keywords:

Feasibility

Dynamic back-off

Linear matrix inequality

Profit control

ABSTRACT

The operating point of a typical chemical process is determined by solving a non-linear optimization problem where the objective is to minimize an economic cost subject to constraints. Often, some or all of the constraints at the optimal solution are active, i.e., the solution is constrained. Though it is profitable to operate at the constrained optimal point, it might lead to infeasible operation due to uncertainties. Hence, industries try to operate the plant close to the optimal point by “backing-off” to achieve the desired economic benefits. Therefore, the primary focus of this paper is to present an optimization formulation for solving the dynamic back-off problem based on an economic cost function. In this regard, we work within a stochastic framework that ensures feasible dynamic operating region within the prescribed confidence limit. In this work, we aim to reduce the economic loss due to the back-off by simultaneously solving for the operating point and a compatible controller that ensures feasibility. Since the resulting formulation is non-linear and non-convex, we propose a novel two-stage iterative solution procedure such that a convex problem is solved at each step in the iteration. Finally, the proposed approach is demonstrated using case studies.

© 2014 Elsevier Ltd. All rights reserved.

1. Background

Profitability is the major concern of a chemical plant and one approach to achieve this is to operate the plant at the optimal point obtained from a non-linear steady state optimizer. The optimizer minimizes a suitable cost function subject to equality and inequality constraints. Often, the solution of the optimizer is constrained at some of the inequalities, that is, there are several active constraints. Typically, it is assumed that these active constraints should be controlled at their limiting values to achieve economic benefits. However, the presence of uncertainties in the form of measurement noise, modeling error, parametric uncertainties and disturbances might cause constraint violations. Therefore, it is important to find an operating point close to the active constraints such that the plant remains feasible for the expected range of uncertainties. Thus, the focus of our work is to propose an optimization formulation that obtains the best trading-off between feasibility and profitability.

Optimal process operations depend on process design and safety thresholds, etc. These constraints define the feasible operating window to the optimizer. To ensure feasible operation under uncertain

conditions, it may be necessary to “back-off” from the active constraints which however results in loss of achievable profit. Hence, the optimizer minimizes a loss function for backing – off from the active constraints. The term “back – off” is defined as,

$$\text{Back – off} = |\text{Actual steady state operating point} - \text{Nominally optimal steady state operating point}| \quad (1)$$

Based on the notion of back-off, Narraway et al. [15] presented a method to assess the economic performance of the plant in the presence of disturbances. To ensure feasibility, the maximum amplitude of the disturbance for a certain range of frequency was used to determine the necessary back-off and alternate designs were evaluated. They assume the set of measurements are perfectly controlled and controllability is tested after obtaining the solution. Later, Narraway and Perkins [16] extended their frequency response based method of estimating the closed loop constraint back off on the assumption of perfect control hypothesis to select the optimal set of measurements and manipulated inputs. This was accomplished by introducing the binary decision variable into the bounds of all possible measurements and manipulations. Also, the method was extended for the case of realistic PI controllers. Although the formulation is an Mixed Integer Linear Program

* Corresponding author. Tel.: +91 4422574177.

E-mail address: sridharkrn@iitm.ac.in (S. Narasimhan).

(MILP), the dimension of the problem is very high owing to the number of frequencies considered for each of the constraints. To solve this, a solution algorithm was presented where the obtained solution is compared with the open loop (without control) solution to quantify the profitability that would be achieved by the controller and the controller with less benefits are eliminated [7]. All of the above methods were developed to handle single disturbance only.

To address the case of multiple disturbances, Bahri et al. [2] addressed the back off problem for control of active constraints in the regulatory layer by solving the open loop problem. Figueroa et al. [5] extended the above approach to the closed-loop case where the figure of merit “maximum percentage recovery” is defined to choose between alternative control configurations. In summary, disturbance is the only source of uncertainty considered in evaluating the different control structures. However, in some cases measurement noise and control error also play a significant role.

Disturbances are typically categorized based on the time scale or frequency of occurrence as fast or high-frequency disturbance and slow or low-frequency disturbance. The lower regulatory layer generally handles the fast disturbances whereas the slow disturbances are handled by the steady state optimizer. The objective of the optimization layer is to provide set points to the control layer. These set points depend on the set of design variables and measurements selected for estimating the model parameters. And, the choice of measurements have a profound impact in the steady state economics. In this regard, de Hennin et al. [8] presented a method for estimating the likely economic benefit that could be achieved by implementing a steady state optimizer. The cost of instrumentation is also included in addition to the operational cost to determine the best optimal measurements. Some of the other works that use the concept of economic back-off in the area of controllability analysis are Young et al. [20] and Bahri et al. [1].

Loeblein and Perkins [10] proposed a measure of average deviation from optimum that allows the estimation of economic value of different online optimization structures. In addition to measurement selection, their work addressed the impact of model uncertainty on the economics of the optimizer. To analyze this issue, the authors considered a simple model, approximate model and rigorous model and concluded that approximate model is appropriate for on-line optimization. Later, Loeblein and Perkins [11,12] extended their method of average deviation from optimum to analyze the dynamic economics of regulatory layer which is assumed to be implemented using Model Predictive Control (MPC) system. However, fixed control structures are assumed to rank between the alternatives.

Peng et al. [19] proposed a stochastic formulation for the determination of back-off points based on the notion of expected dynamic operating region. The basic idea in their approach is that the simultaneous selection of controller and back off point will find an optimal controller that minimizes the variability of the active constrained variables. Since the disturbances are assumed to be stochastic, the dynamic operation is defined in terms of variance. Extensions of the method to discrete time and partial state information case do not alter the formulation. Despite this, the final form of the optimization problem contains a set of reverse convex constraints which make the problem difficult to solve. Therefore, a branch and bound type algorithm was proposed. Sensor selection for control purposes are addressed in this framework [14,18]. Chmielewski and Mantharwar [4] have found that the obtained optimal multivariable feedback controller can be used to tune the objective function weights of the MPC controller.

In this work, we propose a stochastic formulation of the dynamic back-off problem that ensures feasible operation for the prescribed confidence limit. Following Peng et al. [19], the dynamic operating region is defined for the given disturbances which follow from

the closed loop covariance analysis of the state space model of the process. Under rather general conditions, this dynamic region can be characterized as an ellipsoid. The loss function, is a measure of departure from optimality and we develop a theoretically and conceptually sound loss function. Controller selection also plays a crucial role in shaping the dynamic operating region while the size of the region is characterized by the prescribed confidence limit and variance of the disturbance considered. Thus, consideration of the controller gain as a decision variable is important in determining the optimal operating point which minimizes the loss in profit. Therefore, the focus of our work is to propose an optimization formulation that determines the economic backed-off operating point by finding at the same time a suitable controller gain.

The current formulation contains an explicit representation of the ellipsoid to describe the system dynamics and can handle partially constrained cases. Unlike our previous work [13], in the current formulation, the back-off can be viewed as a slack variable in the feasibility constraints. Furthermore, a novel and computationally efficient solution methodology has been presented to solve the non-linear non-convex problem.

This paper is organized as follows. In the next section, we define the problem and present a development of stochastic formulation and convex relaxations of the constraints. Next, a solution algorithm has been developed. Finally, illustrations are provided to demonstrate the approach.

2. Formulation of dynamic back-off problem

The objective of this section is to present an optimization formulation that determines the most profitable steady state operating point given that the plant has to remain feasible for the expected set of disturbances affecting the process. Hence, the optimization formulation should also include differential constraints that characterize the dynamic operating region of the plant. The feasibility becomes an important issue while operating the plant at the constrained optimal point. Therefore, we need to solve a dynamic back-off problem.

2.1. Optimization formulation

We start by determining the Optimal steady state Operating Point (OOP) by minimizing the economic cost (the negative of the operating profit) $J(x_0, u_0, \bar{d}_0)$ where x_0, u_0 and \bar{d}_0 denote the states, manipulated inputs and nominal value of disturbances. Thus, the steady state optimizer solves the non-linear steady state optimization problem of the form,

$$\min_{x_0, u_0} J(x_0, u_0, \bar{d}_0) \quad (2a)$$

$$s.t. \quad g(x_0, u_0, \bar{d}_0) = 0 \quad (2b)$$

$$h(x_0, u_0, \bar{d}_0) \leq 0 \quad (2c)$$

At OOP, the states and manipulated inputs are denoted as x_0^* and u_0^* , respectively. At OOP, there are three possible cases: unconstrained optimum (no active constraints), partially constrained (the number of active constraints is less than the number of manipulated inputs) and fully constrained (the number of active constraints equals the number of manipulated inputs). Peng et al. [19] have addressed the problem for fully constrained case and the back-off from the linearized optimal solution is determined. In the present work, the focus is on the more general partially constrained case. In contrast to the fully constrained case where a linear approximation of the cost function around the optimal point is valid, the partially constrained case requires one to include a quadratic penalty for the inputs to account for the unconstrained degrees of freedom.

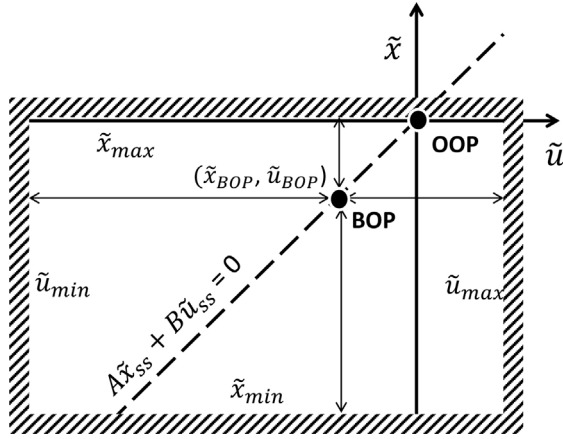

Fig. 1. Feasible region: dynamic (box) and steady state (dashed line).

As mentioned previously, operating at OOP is usually not possible because of disturbances leading to infeasible operation. Therefore it is necessary to back off from the OOP. We introduce the deviation variables with respect to the nominally optimal point: $\tilde{x} = x_0 - x_0^*$, $\tilde{u} = u_0 - u_0^*$ and $\tilde{d} = d_0 - \bar{d}_0$. In the deviation variable space, the optimal operating point is the origin as shown in Fig. 1. Now, linearizing the steady state process models (2b) yield,

$$A\tilde{x}_{ss} + B\tilde{u}_{ss} = 0 \quad (3)$$

where A and B are the partial derivative of g evaluated at $(x_0^*, u_0^*, \bar{d}_0)$. Eq. (3) defines the set of feasible back-off operating points $(\tilde{x}_{ss}, \tilde{u}_{ss})$. This is shown as the dashed line in Fig. 1 for a single input and single output system. Now, the inequality performance limits (2c) are linearized around $(x_0^*, u_0^*, \bar{d}_0)$ and writing in bounded form by defining a new variable z_0 as:

$$z_0 = Z_x x_0 + Z_u u_0 + Z_d \bar{d}_0 \quad (4a)$$

$$z_{\min} \leq z_0 \leq z_{\max} \quad (4b)$$

where Z_x , Z_u and Z_d are the partial derivative of h evaluated at $(x_0^*, u_0^*, \bar{d}_0)$. Re-writing in terms of deviation variables, we get

$$\tilde{z} = Z_x \tilde{x} + Z_u \tilde{u} + Z_d \tilde{d} \quad (5a)$$

$$\tilde{z}_{\min} \leq \tilde{z} \leq \tilde{z}_{\max} \quad (5b)$$

where $\tilde{z}_{\min} = z_{\min} - Z_x x_0^* - Z_u u_0^* - Z_d \bar{d}_0$ and $\tilde{z}_{\max} = z_{\max} - Z_x x_0^* - Z_u u_0^* - Z_d \bar{d}_0$. It is important to note that, $\tilde{d} = 0$ at steady state.

In order to formulate the dynamic back-off problem, we need to define the system dynamics around the back-off point which has to be determined such that the economic loss is minimum. We assume that disturbances are rejected by the linear multivariable controller and full information about the state is available. Now, the dynamic model is rewritten in terms of the new deviation variables around the BOP $(\tilde{x}_{ss}, \tilde{u}_{ss}, \tilde{d})$ and is given by

$$\dot{x} = Ax + Bu + Gd \quad (6)$$

$$x(0) = x_0 \quad (7)$$

$$z = Z_x x + Z_u u + Z_d d \quad (8)$$

$$\tilde{z}_{\min} - \tilde{z}_{ss} \leq z \leq \tilde{z}_{\max} - \tilde{z}_{ss} \quad (9)$$

where $x = \tilde{x} - \tilde{x}_{ss}$, $u = \tilde{u} - \tilde{u}_{ss}$ and $d = \tilde{d} - \tilde{d}_0$. The above set of equations define the dynamic operating region around the BOP.

The optimal operating point determined using (2) is the maximum achievable profit. As mentioned previously, we need to back-off from this optimal point to ensure dynamic feasibility. Hence, we need to define the loss function that minimizes the loss in achievable profit due to backing-off from the non-linear

constrained optimal point. Therefore, we propose a linear approximation of the cost plus a quadratic penalty term to account for input usage,

$$J_x^T \tilde{x}_{ss} + J_u^T \tilde{u}_{ss} + \tilde{u}_{ss}^T J_{uu} \tilde{u}_{ss} \quad (10)$$

where J_x , J_u and J_{uu} are the partial derivatives of J evaluated at $(x_0^*, u_0^*, \bar{d}_0)$. This is contrary to the linear cost function proposed by Peng et al. [19], where the optimal steady state operating point is the result of the linearized model and not the non-linear optimal solution. This quadratic term forces the backed-off point to be closer to the non-linear optimal solution. It is also important to note that the cost function considers only the steady state effect on economics to determine the dynamically feasible steady state operating point. Now, we can pose the dynamic back-off problem for linear systems as

$$\min J_x^T \tilde{x}_{ss} + J_u^T \tilde{u}_{ss} + \tilde{u}_{ss}^T J_{uu} \tilde{u}_{ss} \quad (11)$$

$$\text{s.t. } 0 = A\tilde{x}_{ss} + B\tilde{u}_{ss} \quad (12)$$

$$\dot{x} = Ax + Bu + Gd \quad \forall d \in \mathcal{D} \quad (13)$$

$$x(0) = x_0 \quad \forall x_0 \in \mathcal{X} \quad (14)$$

$$z = Z_x x + Z_u u + Z_d d \quad (15)$$

$$\tilde{z}_{ss} = Z_x \tilde{x}_{ss} + Z_u \tilde{u}_{ss} \quad (16)$$

$$\tilde{z}_{\min} - \tilde{z}_{ss} \leq z \leq \tilde{z}_{\max} - \tilde{z}_{ss} \quad (17)$$

$$u = Lx \quad (18)$$

where \tilde{x}_{ss} , \tilde{u}_{ss} , \tilde{z}_{ss} , L , x and u are the decision variables. \mathcal{D} and \mathcal{X} are the admissible sets of disturbances and initial values. This problem finds the new operating point that is close to the optimal operating point, in the economic sense, with the help of linear controller design as a part of the formulation. It is important to note that the new operating point would be different from the optimal steady state to ensure feasibility caused by some disturbances. The formulation is still semi-infinite dimensional due to differential constraints and non-linear due to the inclusion of controller design. Therefore, in the next section, we present a stochastic framework for addressing the dynamic back-off problem.

2.2. Stochastic framework

In this section, we develop a stochastic formulation that ensures feasible operation modulo, a prescribed confidence limit, i.e., the probability that the constraints are satisfied is greater than or equal to the confidence limit [19]. We make the following assumptions in formulating the problem:

- Disturbances are the only source of uncertainty considered and they are characterized by Gaussian white noise process with zero mean and known variances.
- A linear multi-variable controller with full state information ($u = Lx$) is available for feedback.
- A linear state space model to describe the dynamic operation of the system is given.

The differential equations that define the dynamic operating region can be expressed using the closed loop covariance analysis of the state space model of the process. Under the above-mentioned assumptions, the dynamic operating region can be expressed as ellipsoids with the BOP as center and the size and orientation determined by the covariance. Therefore, the current objective is to formulate the optimization problem that aims at determining the center of the ellipsoid (back-off operating point) and also orient the ellipsoid (i.e., finding a suitable controller) such that the dynamic

operating region remains feasible for the given confidence limit while minimizing the loss in profit.

Following Peng et al. [19], we develop closed loop covariance expressions that describe the expected dynamic operating region (EDOR). In this framework, the EDOR is a region such that the probability that the system is confined to the EDOR is greater than the prescribed confidence limits. This covariance matrix depends on the process dynamics, controller and also on the set of measurement. Assuming full state information and linear feedback, $u = Lx$, the closed-loop steady state covariance matrix of the state vector ($\Sigma_x := \lim_{t \rightarrow \infty} \mathbf{E}[x(t)x(t)^T]$) is given by the Lyapunov equation

$$(A + BL)\Sigma_x + \Sigma_x(A + BL)^T + G\Sigma_dG^T = 0 \quad (19)$$

where Σ_x is the symmetric positive semi-definite solution to the Lyapunov equation. Correspondingly, the covariance of the output signal z is given by

$$\Sigma_z = (Z_x + Z_uL)\Sigma_x(Z_x + Z_uL)^T + Z_d\Sigma_dZ_d^T \quad (20)$$

Given the center, \tilde{z}_{ss} , and the covariance $\Sigma_z = P^2$, the ellipsoidal EDOR is expressed as

$$\mathcal{E} = \{\tilde{z}_{ss} + \alpha Pz \mid \|z\|_2 \leq 1\} \quad (21)$$

where P is the positive square root of Σ_z and α depends on the confidence limit (e.g., for a confidence limit of 95%, $\alpha = 2$). It is important to note that $\tilde{z} = \tilde{z}_{ss} + \alpha Pz$. Therefore, we describe the dynamic feasibility as finding the ellipsoid within the performance bounds which is given by

$$\mathcal{E} = \{(\tilde{z}_{\min} \leq \tilde{z}_{ss} + \alpha Pz \leq \tilde{z}_{\max}) \mid \|z\|_2 \leq 1\} \quad (22)$$

This representation ensures that the whole ellipsoid should lie within the performance bounds defined by (5b). These bounds can be written as $h_i^T \tilde{z} + t_i \leq 0$; $i = 1, \dots, m$ where h_i , t_i are the respective rows and elements of the matrix $H = [I; -I]$ and vector $t = [\tilde{z}_{\max}; -\tilde{z}_{\min}]$. Thus, the problem can be restated as finding the center of the ellipsoid close to the optimal operating point such that the ellipsoid is contained within performance bounds. Thus, we write the EBOP selection problem as

$$\min J_x^T \tilde{x}_{ss} + J_u^T \tilde{u}_{ss} + \tilde{u}_{ss}^T J_{uu} \tilde{u}_{ss} \quad (23a)$$

$$\text{s.t. } 0 = A\tilde{x}_{ss} + B\tilde{u}_{ss} \quad (23b)$$

$$(A + BL)\Sigma_x + \Sigma_x(A + BL)^T + G\Sigma_dG^T = 0 \quad (23c)$$

$$\Sigma_z = (Z_x + Z_uL)\Sigma_x(Z_x + Z_uL)^T + Z_d\Sigma_dZ_d^T \quad (23d)$$

$$P = \Sigma_z^{1/2} \quad (23e)$$

$$\tilde{z} := \tilde{z}_{ss} + \alpha Pz \quad \forall \|z\|_2 \leq 1 \quad (23f)$$

$$h_i^T \tilde{z} + t_i \leq 0; \quad i = 1, \dots, m \quad (23g)$$

where \tilde{x}_{ss} , \tilde{u}_{ss} , \tilde{z}_{ss} , L , $\Sigma_x \geq 0$, $\Sigma_z \geq 0$ and $P \geq 0$ are the decision variables. There are specifically two factors that make the above optimization problem challenging. First, equations (23c)–(23e) are non-linear in the decision variables. Second, the formulation is infinite-dimensional due to the explicit description of the ellipsoid (23f). In other words, we need to find the ellipsoid centered at the BOP for an infinite set of z . Hence, we present convex relaxations of the constraints in the next section.

2.3. Convex relaxations

Convex optimization tools are highly useful in transforming “difficult-to-solve” non-linear constraints into solvable Linear Matrix Inequality (LMI) forms [3]. First, we present some facts from convex optimization and control theory.

Fact 01 Schur complement [3]. If C is positive-definite, i.e., $C > 0$, then the matrix $S = A - BC^{-1}B^T$ is called the Schur complement of C in the matrix $X = \begin{bmatrix} A & B \\ B^T & C \end{bmatrix}$. Then the condition for positive semi-definiteness of block X is: If $C > 0$, then $X \geq 0$ if and only if $S \geq 0$.

Fact 02 S – procedure [3]. The implication

$$x^T F_1 x + 2g_1^T x + h_1 \leq 0 \Rightarrow x^T F_2 x + 2g_2^T x + h_2 \leq 0,$$

where $F_i \in \mathbf{S}^n$, $g_i \in \mathbf{R}^n$, $h_i \in \mathbf{R}$, holds if and only if there exists a τ such that

$$\tau \geq 0; \quad \begin{bmatrix} F_2 & g_2 \\ g_2^T & h_2 \end{bmatrix} \leq \tau \begin{bmatrix} F_1 & g_1 \\ g_1^T & h_1 \end{bmatrix},$$

provided there exists a point \hat{x} with $\hat{x}^T F_1 \hat{x} + 2g_1^T \hat{x} + h_1 < 0$.

Theorem 1. [19] \exists stabilizing L , $\Sigma_x \geq 0$ s.t. $(A + BL)\Sigma_x + \Sigma_x(A + BL)^T + G\Sigma_dG^T = 0$ and $\Sigma_z = (Z_x + Z_uL)\Sigma_x(Z_x + Z_uL)^T + Z_d\Sigma_dZ_d^T$ if and only if $\exists Y, X > 0$ and $Z > 0$ s.t. $(AX + BY) + (AX + BY)^T + G\Sigma_dG^T < 0$,

$$\begin{bmatrix} Z - Z_d\Sigma_dZ_d^T & Z_xX + Z_uY \\ (Z_xX + Z_uY)^T & X \end{bmatrix} > 0.$$

For proof of the above theorem, the reader is referred to Chmielewski and co-workers [19].

Corollary 1. The controller gain is recovered as $L = YX^{-1}$ and the covariance matrix of the states is $\Sigma_x = X$.

Theorem 2. [3] Eq. (23f)–(23g) can be expressed as a set of second order cone constraints of the form $\|\alpha Ph_i\|_2 + h_i^T \tilde{z}_{ss} + t_i \leq 0$

Proof. Recall that the feasibility condition, $h_i^T \tilde{z} + t_i \leq 0 \quad \forall \alpha Pz + \tilde{z}_{ss} \mid \|z\|_2 \leq 1$. This can be rewritten as

$$\begin{aligned} & \sup_{\|z\|_2 \leq 1} h_i^T (\alpha Pz + \tilde{z}_{ss}) + t_i \leq 0, \quad i = 1, \dots, m \\ & \Leftrightarrow \sup_{\|z\|_2 \leq 1} (h_i^T \alpha Pz) + h_i^T \tilde{z}_{ss} + t_i \leq 0, \quad i = 1, \dots, m \\ & \Leftrightarrow \|\alpha Ph_i\|_2 + h_i^T \tilde{z}_{ss} + t_i \leq 0, \quad i = 1, \dots, m \end{aligned}$$

□

Let us consider the covariance constraint (23d) of the output z

$$\Sigma_z = (Z_x + Z_uL)\Sigma_x \Sigma_x^{-1} \Sigma_x (Z_x + Z_uL)^T + Z_d\Sigma_dZ_d^T \quad (24)$$

Taking Σ_x within brackets, we get

$$\Sigma_z = (Z_x \Sigma_x + Z_uL \Sigma_x) \Sigma_x^{-1} (Z_x \Sigma_x + Z_uL \Sigma_x)^T + Z_d\Sigma_dZ_d^T \quad (25)$$

This form allows one to write it as an LMI using change of variables and Schur complement (see Fact 01). Next, let us consider the ellipsoidal constraint (23f) and the output bounds defined by the polytopic constraint (23g). As mentioned previously, these two constraints make the EBOP selection problem as an infinite dimensional one. However, we can represent them as finite number of second order cone constraints using Theorem 2

$$\|\alpha Ph_i\|_2 + h_i^T \tilde{z}_{ss} + t_i \leq 0, \quad i = 1, \dots, m \quad (26)$$

Now the EBOP selection problem is reformulated in terms of LMI constraints as:

$$\min J_x^T \tilde{x}_{ss} + J_u^T \tilde{u}_{ss} + \tilde{u}_{ss}^T J_{uu} \tilde{u}_{ss} \quad (27a)$$

$$\text{s.t. } 0 = A\tilde{x}_{ss} + B\tilde{u}_{ss} \quad (27b)$$

$$\tilde{z}_{ss} = Z_x \tilde{x}_{ss} + Z_u \tilde{u}_{ss} \tag{27c}$$

$$(AX + BY) + (AX + BY)^T + G \Sigma_d G^T < 0 \tag{27d}$$

$$\begin{bmatrix} Z - Z_d \Sigma_d Z_d^T & Z_x X + Z_u Y \\ (Z_x X + Z_u Y)^T & X \end{bmatrix} \geq 0 \tag{27e}$$

$$P = Z^{1/2} \tag{27f}$$

$$\|\alpha P h_i\|_2 + h_i^T \tilde{z}_{ss} + t_i \leq 0, \quad i = 1, \dots, 2n_z \tag{27g}$$

where $\tilde{x}_{ss}, \tilde{u}_{ss}, \tilde{z}_{ss}, Y, X \geq 0, Z \geq 0$ and $P \geq 0$ are the decision variables. The objective function and all the constraints in the above formulation (27) except (27f) are convex. Thus, the formulated minimum back off operating point selection problem is a non-linear non convex program. However, this problem is solved using the solution methodology developed in Section 3.

Remarks.

- The formulation presented in [19] differs from our formulation in many ways: (1) there is no explicit ellipsoidal constraints, (2) the dynamic feasibility of the ellipsoid is ensured by the reverse convex constraints and, (3) a branch and bound type of algorithm was proposed.
- Note that this cost function considers only the steady state effect on economics. Since the disturbances are assumed to be Gaussian and zero mean, this implies that the cost accounts only for the nominal steady state value of disturbances.
- The linear terms in the cost function could be interpreted as the sum of the product of back-off variables and their Lagrange multipliers.
- By direct comparison of (27g) with the robust Linear Programming with random constraints [3],

$$\Phi^{-1}(\eta) \|P h_i\|_2 + h_i^T \tilde{z}_{ss} + t_i \leq 0 \tag{28}$$

we can choose the parameter α using the inverse of the cumulative distribution function $\Phi^{-1}(\eta)$ where η denotes the probability level of a particular constraint being satisfied.

- The term $\|\alpha P h_i\|_2$ denotes the amount of required back-off. Hence, given the controller design, we can directly compute the back-off from the covariance estimates.
- An equivalent LMI representation of the second order cone constraints (27g) is given by S-procedure (see Fact 02) [13],

$$\begin{bmatrix} -\tau_i - h_i^T \tilde{z}_{ss} - t_i & \frac{\alpha}{2} h_i^T P \\ \left(\frac{\alpha}{2} h_i^T P\right)^T & \tau_i I \end{bmatrix} \geq 0; \quad \tau_i > 0; \quad i = 1 \dots 2n_z \tag{29}$$

- Hard and soft constraints could be handled within the proposed formulation by selecting different values α for each of the constraints. Higher value of α is chosen for a hard constraint which signifies that probability of violating that constraint should be less. On the other hand, lower values of α are chosen for soft constraints to achieve the appropriate tolerance level.

3. Solution methodology

The main challenge in obtaining solution to the proposed formulation is the non-linearity in Z . In our formulation, the objective was to orient the ellipsoid (i.e., controller gain, L) such that the center of the ellipsoid is close to optimal operating point (i.e., EBOP, \tilde{z}_{ss}). In this section, we present a solution technique to solve the proposed formulation using the geometrical inference of the solution space. In this regard, we develop a two-stage iterative procedure where a convex problem is solved in each stage.

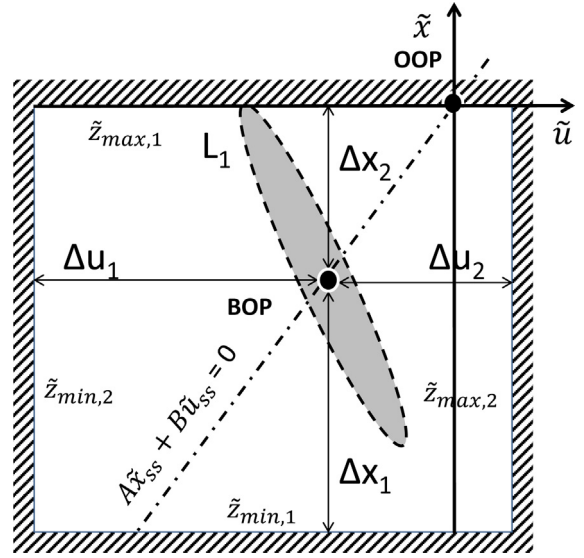

Fig. 2. Non-optimal controller design (solution from stage 1).

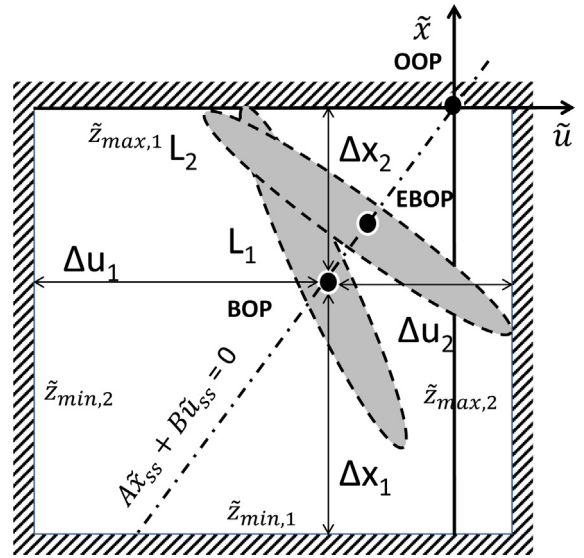

Fig. 3. Optimal controller design (after convergence).

The basic idea of the solution strategy is illustrated in Fig. 2 where we first determine a feasible covariance ellipsoid Z_1 that describes the dynamic operating region for the given confidence limit (say 95%). Next, we determine the backed-off operating point for the computed Z_1 . However, the solution obtained may not be economically optimal as no cost information is included in stage 1. In other words, the backed-off operating point depends critically on the computed Z_1 (solution from stage 1). It can be seen from Fig. 3 that choosing a different covariance ellipsoid Z_2 leads to a better economically backed-off operating point. It should also be noted that at the economic back-off point, the dynamic operating region touches the manipulated input constraint and the active constraint (controlled variable). This illustrates the fact that the dynamic back-off required is due to imperfect control caused by the input constraints for the assumed disturbance magnitude. Hence, the covariance ellipsoid Z_1 is approached toward Z_2 on subsequent iterations by creating lower bounds on the individual variances based on the available manipulated inputs.

3.1. Stage 1

In the first stage, we find the smallest (in terms of trace) feasible ellipsoid Z that describes the dynamic operating region for the considered disturbance magnitude. In other words, we have designed a controller ($L = YX^{-1}$) that result in a minimum variance. At the first stage, we impose the following constraints on the individual variances to determine the Z (and hence L) that ensures feasibility in the second stage,

$$\sigma_{z,i}^2 < \frac{1}{4\alpha^2} (\tilde{z}_{\max,i} - \tilde{z}_{\min,i})^2; \quad i = 1 \dots n_z \tag{30}$$

where $\sigma_{z,i}^2$ is the variance of the i th component of z , viz., z_i . For the given confidence interval (assume 95%), $2\sigma_i$ should be within the performance bounds. This enables us to determine the feasible ellipsoid. Additionally, we define the following constraints with respect to variance of the j th variable $\sigma_{z,j}^2$,

$$\sigma_{z,i}^2 > \frac{\delta_{i,j}^2}{\alpha^2} \sigma_{z,j}^2; \quad i = 1, \quad j - 1, \quad j + 1, \quad n_z \tag{31}$$

where the iterative parameters $\delta_{i,j}^2$ are chosen such that the BOP selected in stage 2 is used to select the new minimum variance ellipsoid that forces the BOP close to OOP. The parameter $\delta_{i,j}$ is defined as

$$\delta_{i,j} = \frac{\text{distance of variable } i \text{ from its closest bound}}{\text{distance of variable } j \text{ from its closest bound}} \tag{32}$$

The δ for the case shown in Fig. 2 is given by

$$\delta_{i,j} = \frac{\min(\Delta u_1, \Delta u_2)}{\min(\Delta x_1, \Delta x_2)} \tag{33}$$

Physically, the solution tries to exploit the available manipulated input space to be utilized to find the economic back-off point and the optimal multi-variable controller. Hence, we solve the following problem to find the dynamic operating region:

$$\min_{X \geq 0, Z \geq 0, Y} \text{Tr}(Z) \tag{34a}$$

$$\text{s.t. } (AX + BY) + (AX + BY)^T + G \Sigma_d G^T < 0 \tag{34b}$$

$$\begin{bmatrix} Z - Z_d \Sigma_d Z_d^T & Z_x X + Z_u Y \\ (Z_x X + Z_u Y)^T & X \end{bmatrix} \geq 0 \tag{34c}$$

$$\sigma_{z,i}^2 < \frac{1}{4\alpha^2} (\tilde{z}_{\max,i} - \tilde{z}_{\min,i})^2; \quad i = 1 \dots n_z \tag{34d}$$

$$\sigma_{z,i}^2 > \frac{\delta_{i,j}^2}{\alpha^2} \sigma_{z,j}^2; \quad i = 1, \quad j - 1, \quad j + 1, \quad n_z \tag{34e}$$

The solution of stage 1 results in a feasible covariance ellipsoid Z_1 . The upper bound on the individual variances ensure that Z_1 is feasible in the second stage. If the solution from stage 1 is infeasible, then the solution to the original problem is infeasible. The parameter δ is used to create lower bounds on the individual variances such that the economically optimal ellipsoid is approached on subsequent iterations. The parameter δ is initialized to zero during the start of the algorithm which defines that the individual variances should be non-negative. Hence, on solving the first stage problem, we obtain Z and letting $P = Z^{1/2}$, a second optimization problem is solved to obtain the back-off point. This would yield an approximation to the economic back-off point.

3.2. Stage 2

$$\min_{\tilde{x}_{ss}, \tilde{u}_{ss}, \tilde{z}_{ss}} J_x^T \tilde{x}_{ss} + J_u^T \tilde{u}_{ss} + \tilde{u}_{ss}^T J_{uu} \tilde{u}_{ss} \tag{35a}$$

$$\text{s.t. } A \tilde{x}_{ss} + B \tilde{u}_{ss} = 0 \tag{35b}$$

Table 1

Algorithm for selecting economic back-off operating point.

1	Initialize the parameter $\delta_{ij} = 0$
2	Find Z by solving the stage 1 convex problem Eq. (34). If no feasible Z can be found, exit
3	Compute $P = Z^{1/2}$. Find the BOP (\tilde{z}_{ss}) by solving the stage 2 convex problem Eq. (35)
4	Terminate on convergence. Otherwise, update δ_{ij} using (32) and proceed to Step 2

$$\tilde{z}_{ss} = Z_x \tilde{x}_{ss} + Z_u \tilde{u}_{ss} \tag{35c}$$

$$\|\alpha P h_i\|_2 + h_i^T \tilde{z}_{ss} + t_i \leq 0, \quad i = 1, \dots, 2n_z \tag{35d}$$

In the second stage, we determine a backed-off operating point (\tilde{z}_{ss}) that is close to the optimal point for the predetermined ellipsoid (solution from the first stage). However, the closeness to the economically optimal point depends on the orientation of the covariance ellipsoid. As we have written the inequalities as box constraints, the surface of the ellipsoid should touch the box at optimality. Hence, we need to re-orient the ellipsoid such that dynamic operating region touches the box constraint. This is accomplished by creating lower bounds for the individual variances using the parameter δ . The δ s are updated based on the newly found backed-off point. This information is used to recompute Z (and hence L) in the first stage. This process is iterated until convergence. And, the recomputed solution approaches the economically optimal operating point. It should be noted that P is not a decision variable since Z is known from the first stage. Now, it can be easily recognized that both stages contains only convex constraints, which could be easily solved using `cvx`, a package for specifying and solving convex programs [6]. Initializing $\delta_{i,j}$ to zero and given two successive iterates, \tilde{z}_{ss}^{iter-1} and \tilde{z}_{ss}^{iter} this process is iterated until the convergence criteria $\|\tilde{z}_{ss}^{iter} - \tilde{z}_{ss}^{iter-1}\|_2 \leq \epsilon$ is satisfied where ϵ being the prescribed tolerance limit. The solution algorithm is presented in Table 1.

4. Examples

4.1. Mass spring damper system

The purpose of this example is to illustrate the proposed backed-off operating point selection algorithm in a single-input two-output system.

Description. Consider the mass-spring-damper system depicted in Fig. 4. Let r denote the mass position, v the velocity, g the gravitational force, f the manipulated input force, and w a disturbance force. The system dynamics are described by linear differential equations [19]:

$$\frac{dr}{dt} = v \tag{36}$$

$$\frac{dv}{dt} = -3r - 2v - g + f + w \tag{37}$$

We will further assume that the system is constrained by the following inequalities $r_{min} \leq r \leq r_{max}$ and $f_{min} \leq f \leq f_{max}$. Hence, the signal matrices are given by $Z_x = \begin{bmatrix} 1 & 0 \\ 0 & 0 \end{bmatrix}$; $Z_u = \begin{bmatrix} 0 \\ 1 \end{bmatrix}$; $Z_d = \begin{bmatrix} 0 \\ 1 \end{bmatrix}$.

BOPs. The economic objective is to bring the mass as close as possible to the upper bound on position. Thus, it can be easily realized that the optimal operating point (OOP) is constrained at the mass position, $r^* = r_{max}$, $v^* = 0$ and $f^* = 3r_{max} + g$ (assuming $f_{max} \geq 3r_{max} + g$). Rewriting in deviation form, the system matrices are $A = \begin{bmatrix} 0 & 1 \\ -3 & -2 \end{bmatrix}$; $B = \begin{bmatrix} 0 \\ 1 \end{bmatrix}$; $G = \begin{bmatrix} 0 \\ 1 \end{bmatrix}$ and the corresponding BOPs which define the steady state feasible points are $\tilde{v}_{ss} = 0$,

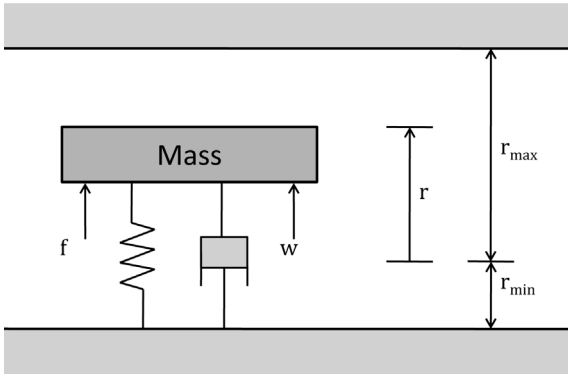

Fig. 4. Mass spring damper system.

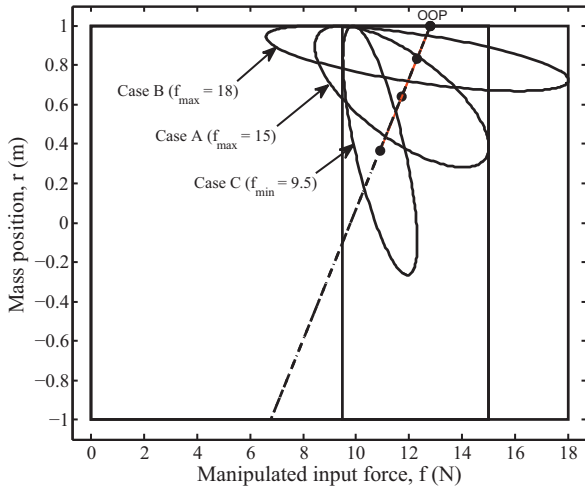

Fig. 5. Impact of change in constraint for mass spring damper system.

$\tilde{f}_{ss} = 3\tilde{r}_{ss}$. The dynamic feasible region is defined by box constraints: $\tilde{r}_{min} \leq \tilde{r} \leq \tilde{r}_{max}$ and $\tilde{f}_{min} \leq \tilde{f} \leq \tilde{f}_{max}$.

Results. If $r_{min} = -1$, $r_{max} = 1$, $f_{min} = 0$, $f_{max} = 15$, $g = 9.8$ and $\Sigma_w = 10$, the OOP is $r^* = 1$, $v^* = 0$ and $f^* = 12.8$ (since $f_{max} = 15 \geq 3r_{max} + g = 12.8$). The data presented here are the base case values (Case A). For the current system, we have assumed a confidence level of 63% (i.e., $\alpha = 1$). The economic backed-off operating point determined is ($r_{EBOP} = 0.64$, $f_{EBOP} = 11.72$) which results in a loss of 0.36. The multi-variable controller ($u = Lx$) designed to operated feasibly at the economic backed-off operating point is $L = [-6.4319 \ -2.1066]$. The results obtained here are in agreement with the results presented in Peng et al. [19]. The impact of change in the constraint polytope is shown in Fig. 5 by increasing the f_{max} to 18 N (Case B) and f_{min} to 9.5 N (Case C). The results are tabulated in Table 2. We see that increasing the upper limit in input force reduces the necessary back-off because this extra input force is used to compensate for the disturbances and hence pushes the mass position close to the optimal point. Whereas increasing the lower bound requires more back-off as it reduces the available

Table 2
EBOP values for change in constraint polytope.

Case	Constraint	(r^*, f^*)	L
A	$f_{max} = 15$	(0.64, 11.72)	[-6.4319 -2.1066]
B	$f_{max} = 18$	(0.83, 12.30)	[-22.883 -5.0544]
C	$f_{min} = 9.5$	(0.36, 10.90)	[-1.6327 -0.6952]

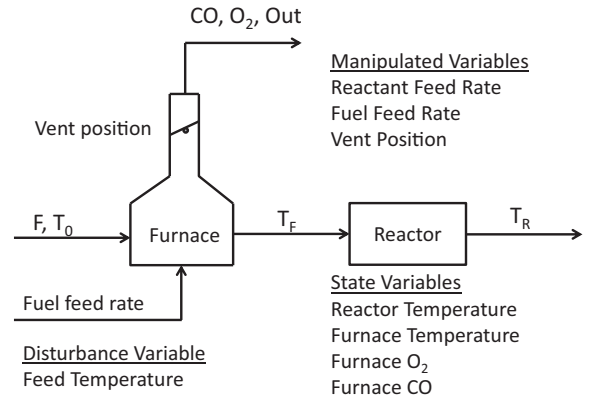

Fig. 6. Preheating furnace reactor system.

dynamic feasible region. Hence, increasing the dynamic feasible region on the input will result in keeping the mass close to the true optimal point.

4.2. Preheating furnace reactor system

This example illustrates the proposed back-off approach in a multi-input multi-output system which is fully constrained at the nominal optimal point.

Description. Consider the preheating furnace reactor system shown in Fig. 6. The system matrices are given by [19]

$$A = \begin{bmatrix} -8000 & 0 & 0 & 0 \\ 2000 & -1500 & 0 & 0 \\ 0 & 0 & -5000 & 0 \\ 0 & 0 & 0 & -5000 \end{bmatrix};$$

$$B = \begin{bmatrix} -75 & 75000 & 0 \\ -25 & 0 & 0 \\ 0 & -8500 & 8.5 * 10^5 \\ 0 & 0 & -5 * 10^7 \end{bmatrix} \text{ and } G = \begin{bmatrix} 10000 \\ 0 \\ 0 \\ 0 \end{bmatrix} \quad (37)$$

where states 1 and 2 correspond to the temperature of the reactor and furnace, T_R and T_F , respectively, and states 3 and 4 correspond to the O_2 and CO concentrations in the furnace, respectively. The manipulated inputs are the changes in the feed flow rate (F_R), fuel flow rate (F_F) and furnace vent position (V_P). Feed temperature, T_0 is assumed as the disturbance input with mean zero and variance $\Sigma_d = (0.13975)^2$. Feasibility is defined by the following state constraints

$$\begin{bmatrix} 355 \\ 495 \\ 3 \\ 70 \end{bmatrix} \leq \begin{bmatrix} T_F \\ T_R \\ C_{O_2} \\ C_{CO} \end{bmatrix} \leq \begin{bmatrix} 395 \\ 505 \\ 5 \\ 130 \end{bmatrix}$$

and input constraints

$$\begin{bmatrix} 9900 \\ 8 \\ 0.09 \end{bmatrix} \leq \begin{bmatrix} F_R \\ F_F \\ V_P \end{bmatrix} \leq \begin{bmatrix} 10100 \\ 12 \\ 0.11 \end{bmatrix}$$

Nominal point. The nominally optimal operating point (OOP) obtained [19] is $x^* = [372, 495, 4.79, 70]^T$ and $u^* = [10100, 9.83, 0.103]^T$. At this point, the active constraints

Table 3
Nominal values and EBOP solution.

Variables	Description	Units	Nominal value	EBOP (closed loop)
<i>States (x)</i>				
T_R	Reactor temperature	°C	495	496.45
T_F	Furnace temperature	°C	372	373.09
C_{O_2}	O ₂ concentration	ppm	4.79	4.2517
C_{CO}	CO concentration	ppm	70	90.083
<i>Inputs (u)</i>				
F_R	Feed flow rate	bbbl/day	10100	10100
F_F	Fuel flow rate	bbbl/day	9.83	9.9458
V_P	Furnace vent position	%	0.103	0.10099

are at the lower limit of CO concentration and furnace temperature and at the upper limit of feed flow rate. In this case, the number of active constraints equal the number of manipulated inputs. Therefore, the system is fully constrained at the optimal point. Hence, the first order approximation of the cost would be suffice for further analysis. The linearized negative profit function (in \$/h) is $J_x = [0, 0, 0, 0.01]^T$; $J_u = [-10, 30, 0]^T$. Next, the performance signal z is defined by the matrices, $Z_x = [I_{4 \times 4} | 0_{4 \times 3}]^T$; $Z_u = [0_{4 \times 3} | I_{3 \times 3}]^T$; $Z_d = [0]$ and the bound constraints written in the form of $h_i^T \tilde{z}_{ss} + t_i \leq 0$ are obtained from the rows of the matrix H and elements of vector t , $H = [I_{7 \times 7} | -I_{7 \times 7}]^T$; $t = [-23, -10, -0.21, -60, 0, -2.17, -0.007, -17, 0, -1.79, 0, -200, -1.83, -0.013]^T$.

Results. The economically optimal operation of the preheating furnace reactor system can be achieved if we control the active constraints (i.e., furnace temperature and CO concentration) and keep the feed flow rate at its upper limit. For the assumed disturbance variances, there is no feasible backed off operating point in the open loop case (without the controller). However, with the help of controller design as a part of the formulation, we find the economic backed off operating point for the system as tabulated in Table 3. At the economic backed off point, the input constraint on feed flow rate is still at its bound which means that the economic value of this input is very high relative to other inputs and hence other inputs are used to achieve profitability. The dynamic operating region along with the economic back-off point for the assumed confidence level is shown in Figs. 7–12. We can see that, in order to ensure dynamic feasibility, the furnace temperature and CO concentration are backed-off from the active constraints whereas feed flow rate requires no back-off. However, increasing the disturbance magnitude may demand the feed flow rate to be backed-off. The optimal multivariable controller gain L designed using our approach is given by

$$L = \begin{bmatrix} 0.001 & 0.008 & 0.010 & 0.000 \\ -0.538 & -4.038 & 5.608 & 0.099 \\ -0.001 & -0.013 & -33.498 & 1.249 \end{bmatrix}$$

It is important to note from the first row of the L matrix that the feed flow rate is hardly adjusted under dynamic conditions. In other words, the feed flow rate should be kept at its limiting value to achieve optimality. Therefore, other inputs (fuel flow rate and vent position) are manipulated to ensure feasible operation under dynamic conditions. The lost profit for operating the system at the economic backed-off operating point is \$3.93 per day.

4.3. Evaporation process

In this example, we illustrate the backed-off operating point selection problem in a partially constrained system, that is, when there exists some unconstrained degrees of freedom at the nominal

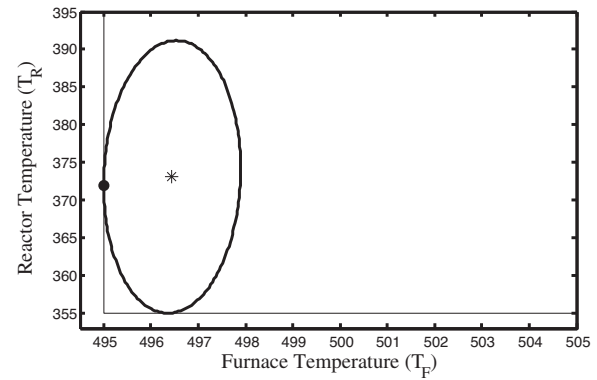

Fig. 7. Furnace temperature vs reactor temperature.

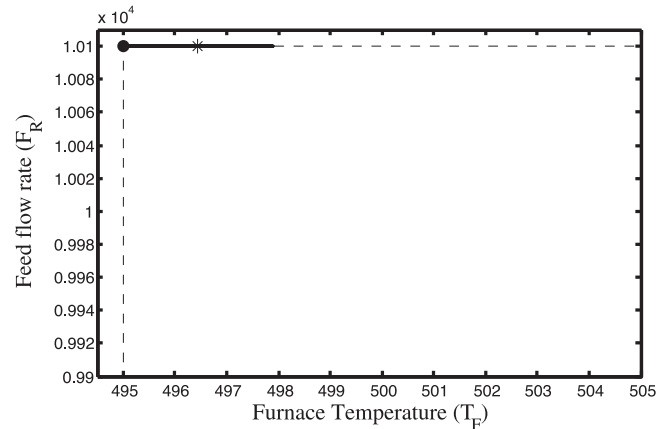

Fig. 8. Furnace temperature vs feed flow rate.

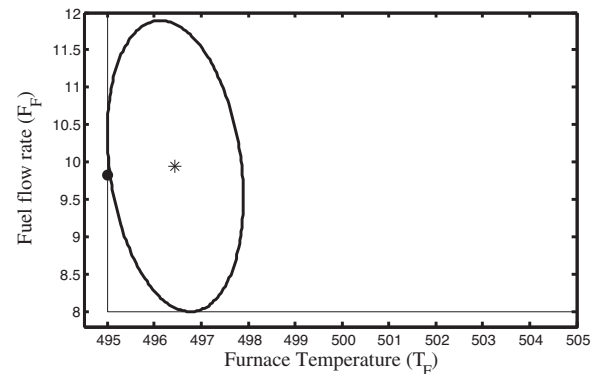

Fig. 9. Furnace temperature vs fuel flow rate.

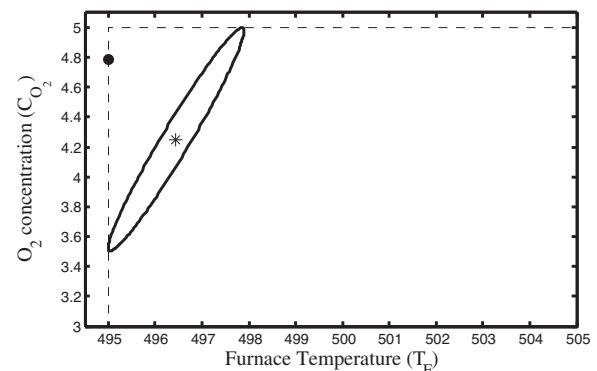

Fig. 10. Furnace temperature vs O₂ concentration.

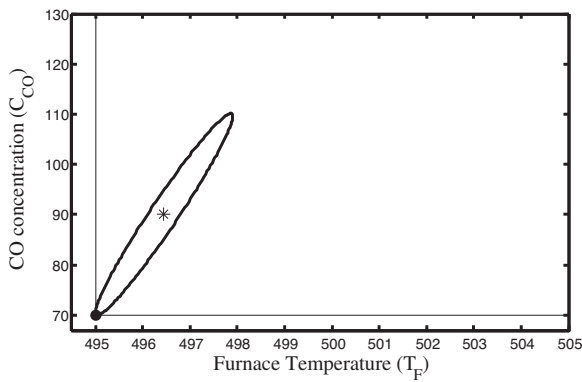

Fig. 11. Furnace temperature vs CO concentration.

optimal point. Further, the economic impact of controller design is addressed.

Description. The forced-circulation evaporator system is depicted in Fig. 13, where the concentration of the feed stream is increased by evaporating the solvent through a vertical heat exchanger with circulated liquor [17]. The overhead vapor is condensed by the use of process heat exchanger. The details of the mathematical model can be found in the original reference. The separator level is assumed to be perfectly controlled using the exit product flow rate F_2 which also eliminates the integrating nature of the state. The economic objective is to maximize the operational profit [\$/h], formulated as a minimization problem of the negative profit [9]. The first three terms of (38) are utility costs relating to steam, coolant and pumping, respectively. The fourth term is the raw material cost, whereas the last term is the product value.

$$J = 600F_{100} + 0.6F_{200} + 1.009(F_2 + F_3) + 0.2F_1 - 4800F_2 \quad (38)$$

The process has the following constraints related to product specification, safety, and design limits:

$$X_2 \geq 35\% \quad (39)$$

$$40 \text{ kPa} \leq P_2 \leq 80 \text{ kPa} \quad (40)$$

$$P_{100} \leq 400 \text{ kPa} \quad (41)$$

$$0 \text{ kg/min} \leq F_{200} \leq 400 \text{ kg/min} \quad (42)$$

$$0 \text{ kg/min} \leq F_1 \leq 20 \text{ kg/min} \quad (43)$$

$$0 \text{ kg/min} \leq F_3 \leq 100 \text{ kg/min} \quad (44)$$

Nominal operating point. The nominal steady state values are obtained by solving a non-linear optimization problem for the nominal values of disturbances and the profit is found to be $J = \$693.41/\text{h}$

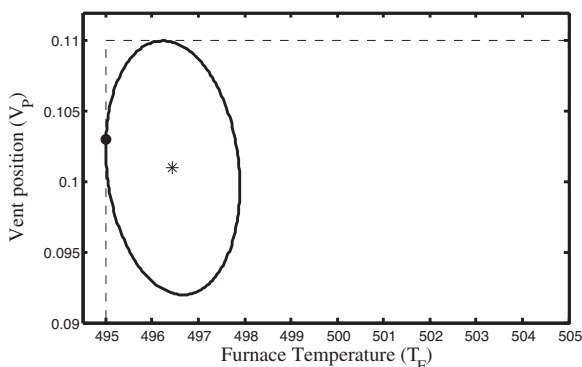

Fig. 12. Furnace temperature vs vent position.

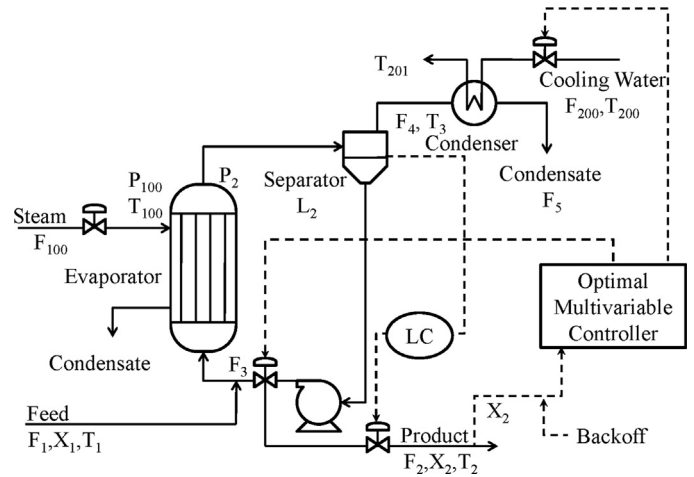

Fig. 13. Evaporator system.

Table 4
Variables and nominal optimal values.

Variables	Description	Nominal value
<i>States (x)</i>		
X_2	Product composition	35.00%
P_2	Operating pressure	56.15 kPa
<i>Inputs (u)</i>		
F_3	Recirculating flow rate	27.70 kg/min
P_{100}	Steam pressure	400 kPa
F_{200}	Cooling water flow rate	230.57 kg/min
<i>Disturbances (d)</i>		
F_1	Feed flow rate	10.00 kg/min
X_1	Feed composition	5.00%
<i>Dependent variables</i>		
F_2	Product flow rate	1.43 kg/min
F_4	Vapor flow rate	8.57 kg/min
F_5	Condensate flow rate	8.57 kg/min
F_{100}	Steam flow rate	9.99 kg/min
Q_{100}	Heat duty	365.63 kW
Q_{200}	Condenser duty	330.00 kW

and the nominal values are shown in Table 4. At the nominal optimal point, there are two active constraints: product composition, $X_2 = 35\%$ and steam pressure, $P_{100} = 400 \text{ kPa}$. The corresponding Lagrange multipliers are $229.36\$/\% \text{ h}$ and $-0.096685\$/\text{kPa h}$, respectively.

Degree of freedom analysis. The process model has seven degrees of freedom. Inlet conditions of the feed (flow rate, composition, temperature) and inlet temperature of the condenser are considered as disturbances (i.e., $d = [F_1 X_1 T_1 T_{200}]^T$). There are three manipulated inputs, $u = [F_3 P_{100} F_{200}]^T$. The disturbance range is assumed to be 10% variation of the nominal value (i.e., $\Sigma_d = \text{diag}([1 \ 0.25 \ 166.25])^2$) and the set of active constraints do not change in the whole range of disturbances. It is important to note that there is one unconstrained degrees of freedom.

Linearized steady state model. A linear approximation of the process model at the nominal optimum yields,

$$A = \begin{bmatrix} -0.16709 & -0.17185 \\ -0.013665 & -0.043132 \end{bmatrix};$$

$$B = \begin{bmatrix} 0.44083 & 0.04217 & 0 \\ 0.062976 & 0.0060243 & -0.0016249 \end{bmatrix};$$

$$G = \begin{bmatrix} -1.2211 & 0.5 & 0.031818 & 0 \\ 0.039837 & 0 & 0.0045455 & 0.03665 \end{bmatrix}$$

The output z are defined by the matrices,

$$Z_x = [I_{2 \times 2} | 0_{2 \times 3}]^T; \quad Z_u = [0_{3 \times 2} | I_{3 \times 3}]^T; \quad Z_d = [0_{4 \times 5}]^T$$

and the bound constraints written in the form of $h_i^T \bar{z}_{ss} + t_i \leq 0$ are obtained from the rows of the matrix H and elements of vector t , $H = [I_{5 \times 5} - I_{5 \times 5}]^T$; $t = [-5, -23.849, -72.299, 0, -169.43, 0, -16.151, -27.701, -200, -230.57]^T$. The linearized negative profit function is

$$J_x = [-293.23, -526.8]^T; \quad J_u = [1368.9, 130.85, 0.6]^T$$

As the input P_{100} is constrained, the quadratic penalty is included only for the unconstrained inputs and the numerical perturbation of inputs F_3 and F_{200} yield,

$$J_{uu} = \begin{bmatrix} 4.4953 & 0.00010226 \\ 0.00010226 & 0.0052699 \end{bmatrix}$$

Results. For the case of full state information, the amount of back off required to remain feasible for a 10% variation in the nominal disturbances is tabulated in Table 5. It is to be noted that the amount of back-off for steam pressure (P_{100}) is zero as expected as it is a input variable. However, the assumed disturbances have significant effect on product exit composition, X_2 . The EBOP solution and EDOR for the open loop and closed loop case are shown as ellipses in Figs. 14–17. The loss obtained for operating the evaporator at this backed off operating point is \$58.65/h which corresponds to the achievable profit of \$634.76/h. In other words, the loss we incur to ensure feasible operation with 95% confidence interval is \$58.65/h. Indeed, the back-off estimated is the best possible lower bound for the product composition to ensure feasibility because of the simultaneous consideration of controller in the formulation. This could be inferred from Table 5 by comparing the closed loop solution with the open loop solution. The multivariable feedback controller ($u = Lx$) to be implemented to operate the system profitably is

$$L = \begin{bmatrix} -108.5643 & 0.3868 \\ -0.0606 & 0.0002 \\ -123.2216 & 97.3625 \end{bmatrix}$$

Without the controller (open loop case), the amount of back off required is higher and the process would incur a loss of \$414.92/h. Note that the optimal controller is using both F_3 and F_{200} to control the product composition with the aim of minimizing the overall cost. The corresponding state feedback gain could be used to determine the appropriate objective function weights using the inverse optimality results of [4] and could then be implemented using model predictive control. The back off operating point determined above is given as set point to the control system. It is important to note that without the quadratic term, the EBOP solution obtained by solving formulation (27) is $[x^T u^T] = [35.41, 76.53, 35.80, 399.99, 0.01]$. Note that for instance, F_{200} is changed from 230.57 to 0.01 kg/min, which is unrealistic. This corresponds to the lower left corner in Fig. 17. Hence, the quadratic term in the cost function is important in the partially constrained case to get a meaningful solution.

Computational issues. In order to study the computational complexity of the algorithm, we present the number of iterations and total CPU time taken by the proposed two-stage iterative solution scheme in Table 6. The algorithm is implemented on a Windows machine with Intel(R)Core(TM)i7 processor @ 3.4 GHz CPU and 4 GB of RAM. At each iterating step, two convex problems are solved. The size of the problem (number of states and inputs) and the feasible

Table 5
Nominal and back-off operation.

Variables	Units	Nominal value	EBOP solution	
			Closed loop (proposed)	Open loop ($u=0$)
<i>States</i>				
X_2	%	35.00	35.26	39.75
P_2	kPa	56.15	56.10	55.16
<i>Inputs</i>				
F_3	kg/min	27.70	27.78	29.12
P_{100}	kPa	400.00	400	400
F_{200}	kg/min	230.57	232.71	271.65
Profit	\$/h	693.41	634.76	-414.92

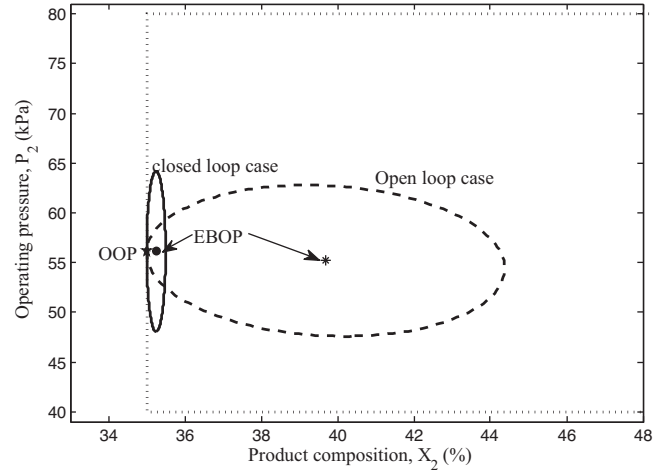

Fig. 14. Product composition vs operating pressure. (a) Open loop case: F_3 and F_{200} are constant. (b) Closed loop case: F_3 and F_{200} are used for control of X_2 .

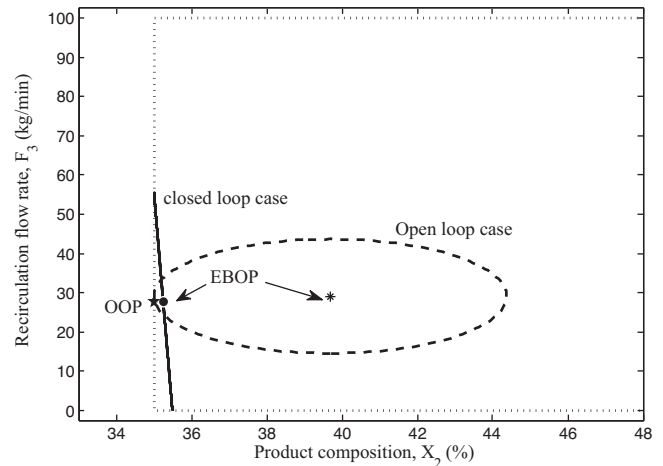
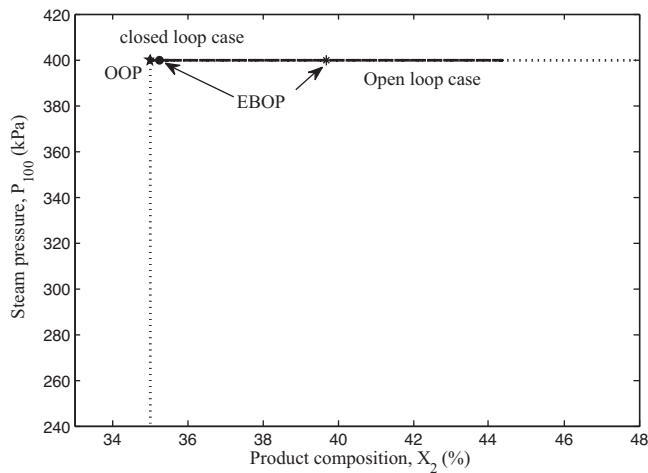
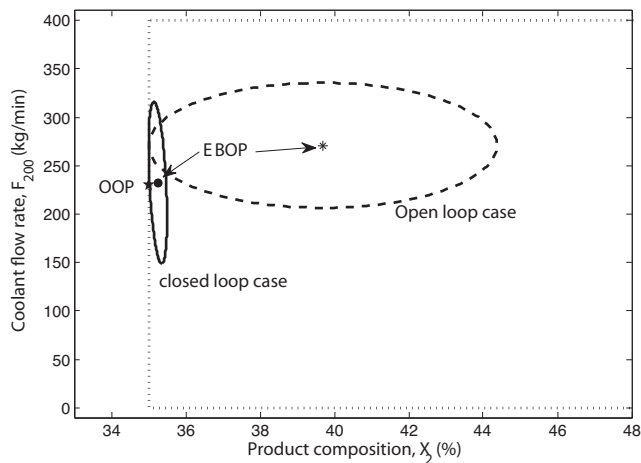

Fig. 15. Product composition vs recirculation flow rate.

input space (as defined by the bounds) determines the fastness of the algorithm. From the results of mass spring damper system presented in Table 6, it can be inferred that for all three cases the time taken per iteration are almost the same. This could be attributed to the size of the problem solved at each iteration being the same. The increase in size increases the time taken per iteration, as seen from the results of pre-heater furnace reactor system and evaporator system. On the other hand, the number of iterations depends on the size of the feasible input space as the solution progresses along the iteration by redefining the bounds on the variance of inputs.

Table 6
Computational efficiency.

Case study	States	Inputs	CPU time (s)	No. of iterations	Time/iter (s)
Mass spring damper system – Case A	2	1	4.0747	8	0.5093
Mass spring damper system – Case B	2	1	7.0932	14	0.5066
Mass spring damper system – Case C	2	1	6.4460	14	0.4604
Pre-heater reactor furnace system	4	3	6.6480	6	1.1080
Evaporator system	2	3	5.7975	9	0.6441

**Fig. 16.** Product composition vs steam pressure.**Fig. 17.** Product composition vs coolant flow rate.

5. Conclusions

A stochastic formulation to compute the most profitable and feasible operating point for Gaussian white noise type disturbances has been presented. A two-stage iterative algorithm has been proposed to solve the dynamic back-off problem. Several case studies here demonstrate the generality of the formulation (i.e., applicability to both fully constrained and partially constrained cases). In particular, the evaporator system demonstrated the need for quadratic cost function in partially constrained systems to achieve meaningful economic backed-off point. Since the controller is a decision variable in the formulation, the most economical operating point is determined which, in fact, gives the best possible lower

bound of the achievable profit. The formulation can be extended to include measurement noise as an additional source of uncertainty.

Acknowledgements

The first author acknowledges the financial support received from the Research Council of Norway through the Yggdrasil Grant Project Number 210897/F11.

References

- [1] P. Bahri, J. Bandoni, G. Barton, J. Romagnoli, Back-off calculations in optimising control: a dynamic approach, *Computers & Chemical Engineering* 19 (Suppl. 1) (1995) 699–708.
- [2] P. Bahri, J. Bandoni, J. Romagnoli, Effect of disturbances in optimizing control: steady state open loop backoff problem, *AIChE Journal* 42 (1996) 983–994.
- [3] S. Boyd, L. Vandenberghe, *Convex Optimization*, Cambridge University Press, New York, USA, 2004.
- [4] D.J. Chmielewski, A.M. Manthanwar, On the tuning of predictive controllers: inverse variance optimality and the minimum variance covariance constrained control problem, *Industrial & Engineering Chemistry Research* 43 (2004) 7807–7814.
- [5] J. Figueroa, P. Bahri, J. Bandoni, J. Romagnoli, Economic impact of disturbances and uncertain parameters in chemical processes – a dynamic back-off analysis, *Computers & Chemical Engineering* 20 (1996) 453–461.
- [6] M. Grant, S. Boyd, *CVX: Matlab Software for Disciplined Convex Programming*, Version 1. 21, 2011.
- [7] J.A. Heath, I.K. Kookos, J.D. Perkins, Process control structure selection based on economics, *AIChE Journal* 46 (2000) 1998–2016.
- [8] S. de Hennin, J. Perkins, G. Barton, Structural decisions in on-line optimization, in: *Proceedings of PSE '94*, Kyongju, Korea, 1994, pp. 297–302.
- [9] V. Kariwala, Y. Cao, S. Janardhanan, Local self-optimizing control with average loss minimization, *Industrial & Engineering Chemistry Research* 47 (2008) 1150–1158.
- [10] C. Loeblein, J. Perkins, Economic analysis of different structures of on-line process optimization systems, *Computers & Chemical Engineering* 22 (1998) 1257–1269.
- [11] C. Loeblein, J.D. Perkins, Structural design for on-line process optimization: I. Dynamic economics of MPC, *AIChE Journal* 45 (1999) 1018–1029.
- [12] C. Loeblein, J.D. Perkins, Structural design for on-line process optimization: II. Application to a simulated FCC, *AIChE Journal* 45 (1999) 1030–1040.
- [13] M. Nabil, S. Narasimhan, S. Skogestad, Economic back-off selection based on optimal multivariable controller *Advanced Control of Chemical Processes*, vol. 8, 2012, pp. 792–797.
- [14] M. Nabil, S. Skogestad, S. Narasimhan, Optimal selection of sensor network and backed-off operating point based on economics, in: *European Control Conference (ECC)*, 2013, pp. 4472–4477.
- [15] L. Narraway, J. Perkins, G. Barton, Interaction between process design and process control: economic analysis of process dynamics, *Journal of Process Control* 1 (1991) 243–250.
- [16] L.T. Narraway, J.D. Perkins, Selection of process control structure based on linear dynamic economics, *Industrial & Engineering Chemistry Research* 32 (1993) 2681–2692.
- [17] R.B. Newell, P. Lee, *Applied Process Control: A Case Study*, Prentice Hall, New York, 1989.
- [18] J. Peng, D. Chmielewski, Optimal sensor network design using the minimally backed-off operating point notion of profit, in: *American Control Conference*, 2005, pp. 220–224.
- [19] J.K. Peng, A.M. Manthanwar, D.J. Chmielewski, On the tuning of predictive controllers: the minimum back-off operating point selection problem, *Industrial & Engineering Chemistry Research* 44 (2005) 7814–7822.
- [20] J. Young, C. Swartz, R. Ross, On the effects of constraints, economics and uncertain disturbances on dynamic operability assessment, *Computers & Chemical Engineering* 20 (Suppl. 1) (1996) S677–S682.