

Control structure selection for three-product Petlyuk (dividing-wall) column

Deeptanshu Dwivedi^a, Ivar J. Halvorsen^b, Sigurd Skogestad^{a,*}

^a Department of Chemical Engineering, Norwegian University of Science and Technology, N-7491 Trondheim, Norway

^b SINTEF ICT, Applied Cybernetics, N-7465 Trondheim, Norway

ARTICLE INFO

Article history:

Received 2 August 2012

Received in revised form 21 October 2012

Accepted 14 November 2012

Available online 23 November 2012

Keywords:

Energy efficient distillation
Thermally coupled distillation
Control structure design
Dividing-wall columns
Petlyuk Column

ABSTRACT

This paper deals with selecting control structures for a three-product Petlyuk (dividing-wall) column with an objective to achieve desired product purities with minimum use of energy (V). We consider four alternate control structures with and without the vapor split as a degree of freedom. This work also demonstrates the usefulness of the graphical V_{\min} diagram to visualize minimum boilup requirement and choose the appropriate control structure.

© 2012 Elsevier B.V. All rights reserved.

1. Introduction

For three-product separations, the Petlyuk (see Fig. 1 [23]) or divided-wall arrangements [14] offer significant savings in both energy and capital costs, as also shown by Cahn and DiMiceli [5], and Stupin [28]. The German company, BASF has more than 100 dividing-wall columns [14]. However, operation and control is challenging and this paper proposes some new control schemes which are workable for varying feed composition disturbances.

Halvorsen and Skogestad [11,13] have developed a graphical tool, the “ V_{\min} diagrams”, to visualize the minimum energy requirement for sharp and non-sharp separations in conventional and thermally coupled columns. This tool can be used for designing such arrangements [7] and we will also demonstrate its use to give some insights into control and operation.

In terms of operation, several works have been published. Mutalib and Smith [20] reported simulation studies on the divided-wall columns. In their second work, Mutalib et al. [21] reported experimental studies conducted on a pilot plant and recommended a two point control of the system. Wolff and Skogestad [29] did a steady state study and operability analysis on a three-product Petlyuk column and conclude that the simultaneous specification of both impurities in the side-product is generally infeasible. Further, the liquid and vapor split ratios between pre-fractionator and the main column should be manipulated to get the optimal energy

benefits. If the vapor split is not available as a degree of freedom, which is normally the case, one cannot control both ends of the pre-fractionator at the same time. Christiansen and Skogestad [6], Halvorsen and Skogestad [10] therefore proposed to use the liquid split to control the key impurity in the least pure end of the pre-fractionator. Ling and Luyben [18] explained that the liquid split valve (R_L) must be manipulated and proposed a control structure with the use of four composition loops with the liquid split controlling the heavy key at the top stage of the pre-fractionator. In their second work, Ling and Luyben [19] studied the effectiveness of temperature control for BTX columns. Similar to Ling and Luyben [18], Kiss and Rewagad [15] and Rewagad and Kiss [24] suggested that control of the heavy key at the pre-fractionator top together with three composition loops in the main column may be sufficient to yield high-purity products and “implicitly” minimize the energy usage. Niggemann et al. [22] conducted simulation and experimental studies for separation of a mixture of fatty alcohols into three high-purity products. They reported that the heat transfer across the dividing wall can be a factor in design and operation. Lestak et al. [16] argued that in some cases the heat transfer across the dividing wall may decrease the overall energy consumptions. In non-beneficial regions however, the wall should be insulated. Some other works on the suitability of Model Predictive Control for dividing-wall columns have also been reported [24,4,1]. Ling et al. [17] suggested a control structure to avoid remixing of the intermediate component for optimal operation.

In this paper, we study the separation of a feed with components A (lightest), B and C (heaviest) in a Petlyuk column as shown in Fig. 1. Note that the letter B is also used to denote the bottom product. To

* Corresponding author. Tel.: +47 735 94154.

E-mail address: skoge@ntnu.no (S. Skogestad).

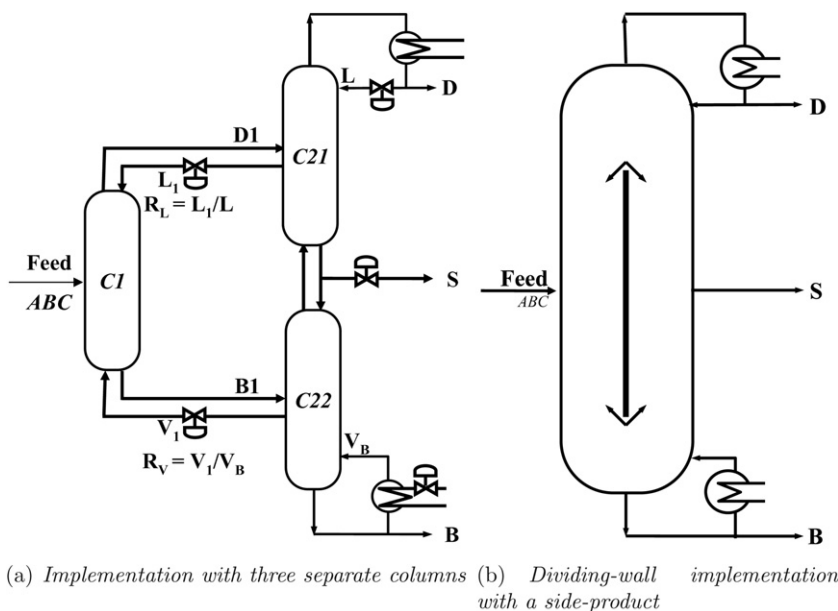

Fig. 1. Thermodynamically equivalent implementations of three-product Petlyuk column.

avoid confusion, we will use subscripts for components and superscripts for products. For example, x_A^D denotes the mole fraction of component A in product D.

With a given feed, the three-product Petlyuk column in Fig. 1 has a total of five steady-state degrees of freedom, if we include an adjustable vapor split (R_V). To obtain minimum energy operation, two of these degrees of freedom (R_L and R_V) must be used to control the purity of the two “products” in the prefractionator (C1 in Fig. 1) [10]. This leaves three degrees of freedom D , S and B in the main column (C21 and C22 in Fig. 1), but we have four key impurities to control:

1. Heavy key or component B in product D (x_B^D).
2. Light key or component A in product S (x_A^S).
3. Heavy key or component C in product S (x_C^S).
4. Light key or component B in product B (x_B^B).

In agreement with Wolff and Skogestad [29], we find that these four compositions cannot be specified independently, but we find that there is a possibility to over-purify one product, with the other products at their specifications. The aim of this work is to find some simple single-loop (decentralized) PI control structures that are workable for large feed disturbances.

2. Case study

The data for the case study are given in Table 1. The process is modeled in Matlab using the simplifying assumptions of constant relative volatility and constant internal molar flows in column sections. This may seem unrealistic but similar results are obtainable for real mixtures. The three hypothetical components A, B and C have relative volatilities similar to the mixture of ethanol, propanol and *n*-butanol. We assume constant pressure, negligible vapor holdup, a total condenser and equilibrium on all stages. We assume linearized liquid flow dynamics. Compared to the product purities given in Table 1, we have a large number of stages in each sub-column. This implies that the required energy is close to the minimum energy using an infinite number of stages. The nominal composition profiles are shown in Fig. 2. Note that the nominal

Table 1

Input data and nominal conditions for the three-product Petlyuk column model.

Relative volatilities [A, B, C]	[4.22.11]
Number of stages in C1	20+20
Number of stages in C21	20+20
Number of stages in C22	20+20
Nominal feed flow rate (F)	1 kmol/min
Nominal feed composition [A, B, C]	[33.3 33.3 33.3] (mol%)
Nominal liquid reflux (L)	1.0033 kmol/min
Nominal boilup (V)	1.3381 kmol/min
Nominal distillate flow rate (D)	0.3348 kmol/min
Nominal bottom flow rate (B)	0.3333 kmol/min
Nominal side-product (S)	0.3318 kmol/min
Nominal liquid split (R_L)	0.3465
Nominal vapor split (R_V)	0.5982
Nominal purity of distillate (x_A^D)	99.5 (mol%)
Nominal purity of side-product (x_B^S)	99.45 (mol%)
Nominal light impurity of side-product (x_C^S)	0.05 (mol%)
Nominal heavy impurity of side-product (x_C^S)	0.5 (mol%)
Nominal purity of bottom product (x_C^B)	99.5 (mol%)
Nominal heavy impurity of prefractionator top (x_C^{D1})	0.29 (mol%)
Nominal light impurity of prefractionator bottoms (x_A^{B1})	0.08 (mol%)

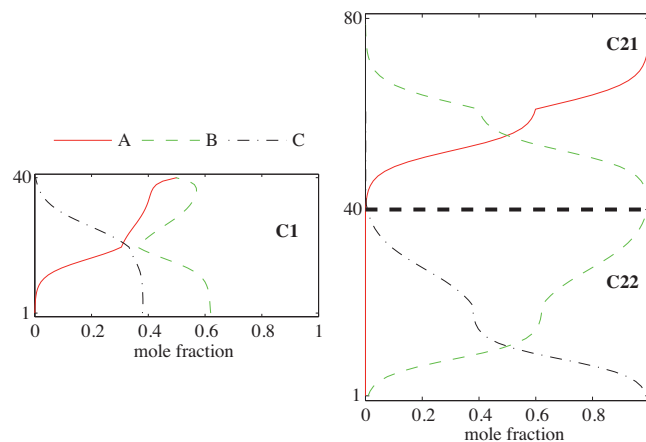

Fig. 2. Nominal composition profiles of components: A (ethanol), B (propanol) and C (*n*-butanol) in sub-columns C1, C21 and C22.

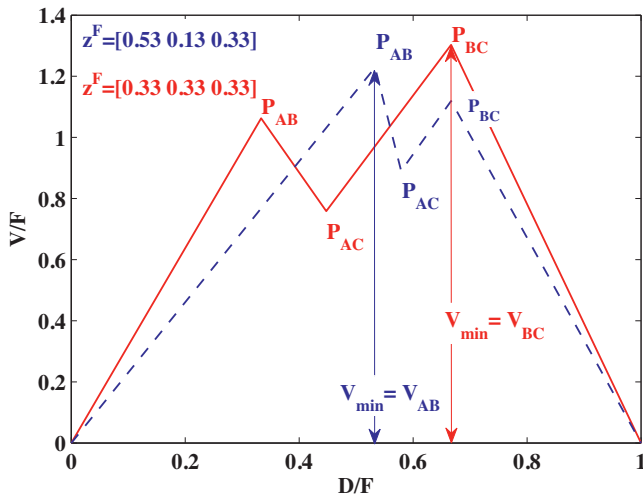

Fig. 3. V_{\min} diagrams for nominal equimolar feed (solid-red line) and for feed composition, z_2^F (mol%) = [53.33 13.33 33.33] (dashed-blue line). Relative volatilities, $\alpha = [4.2 \ 2.1 \ 1]$ and feed liquid fraction, $q_f = 1$. (For interpretation of the references to color in this figure legend, the reader is referred to the web version of the article.)

data in Table 1 (with $V = 1.3381$ kmol/min) do not correspond to minimum energy operation ($V = 1.3322$ kmol/min) for the given product specifications. As explained in more detail in Section 3.2, we choose to “overpurify” the prefractionator as a safeguard against disturbances. We also operate with an overpurified side stream with only 0.05% A, which is well below the allowed 0.5% A.

Fig. 3 shows the V_{\min} diagram for our A–C mixture with a liquid feed. The y-axis shows the normalized minimum boilup (V/F) and the x-axis shows the net product withdrawal (D/F) in a conventional two-product column. The red-solid line is for the nominal equimolar feed and the blue-dashed line is for a feed composition disturbance where the ratio of components A and B is changed from 1:1 to about 4:1.

For Petlyuk arrangements, the minimum energy requirement to separate a multi-component feed is equal to the “most difficult binary separation” [8,12].

$$V_{\min, \text{Petlyuk}} = \max(V_{AB}, V_{BC}) \quad (1)$$

Here, V_{AB} and V_{BC} are the vapor flows corresponding to the peaks P_{AB} and P_{BC} , respectively, in Fig. 3. For the nominal case with an equimolar feed, the P_{BC} peak is the highest. This implies that nominally, B/C is the most difficult binary split in terms of energy usage. However, for the feed composition disturbances, the A/B split becomes the most difficult split. Depending on whether A/B or B/C is the more difficult split, we will have excess energy in one of the sections (C21 or C22, respectively) of the main column. Therefore, there is a possibility to over-purify in one of these two sections with only minor penalty in terms of energy usage. When A/B is the more difficult split, we may choose to over-purify the bottom product or the heavy component (C) in the side-product, and when B/C is the more difficult split, we may choose to over-purify the top product or the light component (A) in the side-product.

3. Control structures for three-product Petlyuk column

3.1. Control objectives

We assume that the operational objective for a given feed is to minimize the energy consumption subject to satisfying purity

constraints on the three products. That is, the cost function to be minimized is:

$$J = \text{Energy } (V) \quad (2)$$

A more general cost function would be to take into account also the prices and amounts of products and of heat input and cooling, but this is not considered here. The purity constraints are assumed to be given in terms of the amount of key impurity in each product:

$$\begin{aligned} \text{Impurity in top product (D): } & x_B^D \leq x_{B,s}^D \quad (= 0.5\%) \\ \text{Light impurity in side product (S): } & x_A^S \leq x_{A,s}^S \quad (= 0.5\%) \\ \text{Heavy impurity in side product (S): } & x_C^S \leq x_{C,s}^S \quad (= 0.5\%) \\ \text{Impurity in bottom product (B): } & x_B^B \leq x_{B,s}^B \quad (= 0.5\%) \end{aligned} \quad (3)$$

Note that the side-product contains the two impurities (A and C). The resulting minimum purity of the main component in each product is 99.5% for the distillate, 99.0% for the side-product and 99.5% for the bottom product.

We assume that these four constraints are always optimally active, meaning that the energy consumption ($J = V$) is minimized by having equality for the four specifications in (3).¹ However, as discussed by Wolff and Skogestad [29], their may be “holes” in the operating range making it difficult or impossible in practice to control all four compositions simultaneously. Instead of controlling four compositions, we therefore, consider two options for controlling three compositions:

1. *Option I:* Control the total impurity in the side stream $x_A^S + x_C^S$ (as done in structure CS1, see Fig. 4(a)).
2. *Option II:* Over-purify one of the products (as done in structure CS2, see Fig. 4(b)). This will come at some loss in terms of energy (V) but as discussed in the previous section, the loss may be very small.

To satisfy three of the specifications in (3) using “Option I” or “Option II”, we need three degrees of freedom (e.g., L , S and V).² There are then two unconstrained degrees of freedom (e.g., R_L and R_V) left for minimizing the energy ($J = V$) and these need to be translated to control objectives.

One may think that a good approach would be to set the energy input (boilup) V directly and try to minimize it, but this is not a workable solution as it may lead to infeasibility because the product specifications cannot be met if V is set lower than its optimal (minimum) value. The concept of “self-optimizing control” [25] provides a general theory for obtaining good control objectives. In this paper, we assume that good self-optimizing variables are the two “product” compositions in the prefractionator (C1) [10]. This is reasonable because the prefractionator will then operate very close to its “preferred” split. Thus, we use the following controlled variables (specifications):

$$\begin{aligned} \text{Heavy key (C) in top “product” of prefractionator (D1): } & x_C^{D1} = x_{C,s}^{D1} \\ \text{Light key (A) in bottom “product” of prefractionator (B1): } & x_A^{B1} = x_{A,s}^{B1} \end{aligned} \quad (4a)$$

¹ Alstad et al. [3] have shown that in some cases it may be possible to obtain some minor energy savings by over-purifying the top product (for the case when B/C is the difficult split) or the bottom product (for the case when A/B is the difficult split), because this simplifies the separation in the side-product by increasing the amount of component B in the side-product. However, the effect is small, and we here assume that all product purity specifications are optimally active.

² It may seem strange that the cost variable $J = V$ is also a degree of freedom, but this is correct.

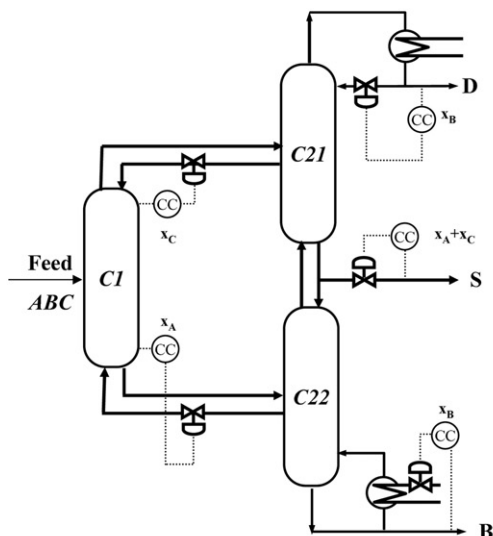

(a) CS1: control of x_A+x_C in sidestream (*Not recommended for dynamic reasons*).

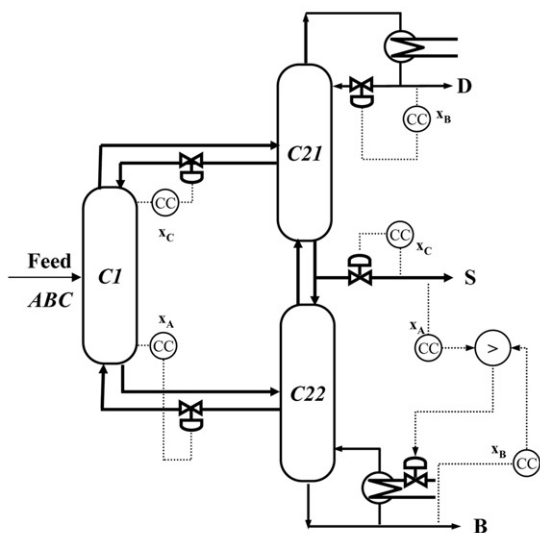

(b) CS2: control of x_C in sidestream and max-selector to avoid x_A in side stream (*Recommended for all feed compositions*).

Fig. 4. Control structures with active use of vapor split (R_V).

3.2. Setpoints for the controlled variables

The setpoints for the compositions in the main column are determined by the product specification as given in (3). For the prefractionator, the setpoint values in (4a) should ideally be the optimal values that minimize the energy consumption (V). The optimal value may vary depending on the feed composition and product purity specifications (for D , S and B), but since the prefractionator performs the “easy” A/C-split, we usually have enough stages to “over-purify” in the prefractionator, with only a slight penalty in terms of increased energy (V). Some over-purification in prefractionator is also good from operational perspective, as we can then avoid the problem of infeasibility of purity specifications in the main column, in the event of disturbances. This is equivalent to the introducing a “back-off” from the

self-optimizing variable as also described by Govatsmark and Skogestad [9].

In our case study, we use for in all simulations and control studies (and for the nominal point) the following specifications for the prefractionator:

$$\begin{aligned} x_{C,S}^{D1} &= 0.29\% \\ x_{A,S}^{B1} &= 0.08\% \end{aligned} \quad (4b)$$

How did we arrive at these values? This is quite a long story, but let us first repeat that the exact values are not critical because the A/C split performed in the prefractionator is relatively easy. We started by obtaining the optimal solution for the nominal feed composition: For the constraints in (3) and the objective (2) we found a minimum boilup (V) of 1.3322 kmol/min with all the four impurity constraints in (3) optimally active. However, this “optimal” solution has some undesirable features. First, we find that the amount of component C over the top in the prefractionator is high (0.83%) given that we want less than 0.5% C in the side-product. Second, this “optimal” solution does not over-purify any of the products, in spite of the fact that we know from the V_{\min} diagram in Fig. 3 (where we see that A/B is the easier split at nominal feed conditions) that we can over-purify either the top product or the side product with almost no extra energy (V). In some sense we can say that the “optimal” solution is going against the “natural” product distribution, which is to over-purify one of the products. Which product should we over-purify? This is mainly an operational issue, and we choose to over-purify A in the side stream. This makes control of the side stream easier, since we at least nominally need not consider the amount of A in the side-product. So we reduced the impurity of A in the side stream from its specification of 0.5–0.1%, and re-optimized the operation. The resulting boilup (V) increased only marginally from 1.3322 kmol/min to 1.3325 kmol/min, so we can indeed over-purify for free. The resulting optimal values for the “product” compositions in the prefractionator were: $x_{C,\text{opt}}^{D1} = 0.58\%$ and $x_{A,\text{opt}}^{B1} = 0.16\%$. However, this is for the nominal feed composition, and to handle feed compositions changes, we choose divide these values by a factor 2 and ended up with the final specifications in (4b). Using the specifications in (4b), resulted in a slight further increase in boilup (V) from 1.3325 kmol/min to 1.3381 kmol/min, and it gave a further reduction of A-impurity in the side stream from 0.10% to 0.05%. The final nominal flows and purities are given in Table 1.

So far, we have assumed that the vapor split (R_V) is a degree of freedom. Unfortunately, this is not the case with most (if not all) Petlyuk columns in operation. Thus, for practical columns, where R_V is not a degree of freedom, we generally need to use extra energy, and the result is that we will get over-purification (inequality) for yet one more of the purities in (3) and (4).

3.3. Control structures

With this introduction to the control objectives and setpoints, we now consider four alternative control structures; CS1 and CS2 (Fig. 4) are for the next-generation dividing-wall columns where the vapor split (R_V) is available as a degree of freedom, whereas CS3 and CS4 (Fig. 5) are for the more realistic case today where R_V is not a degree of freedom.

Note that in all cases, we use the standard “LV-configuration” where the distillate flow (D) is used for level control of the condenser and the bottoms flow (B) is used for level control of the reboiler, so that reflux (L) and boilup (V) remain as degree of freedom for composition control.

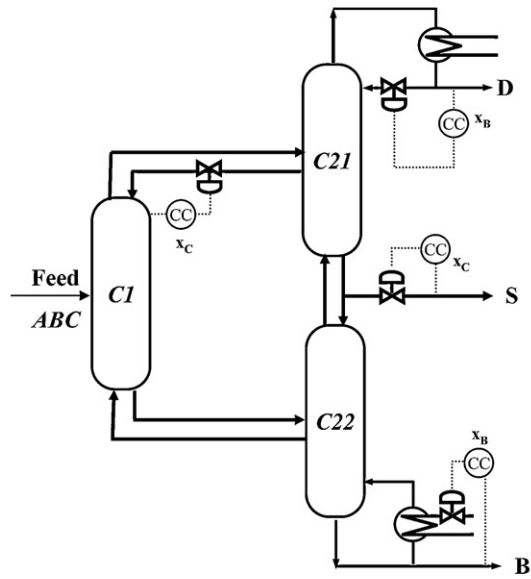

(a) CS3: No control of x_A in sidestream and in bottom of prefractionator [18] (*Recommended when A/B is the easy split*).

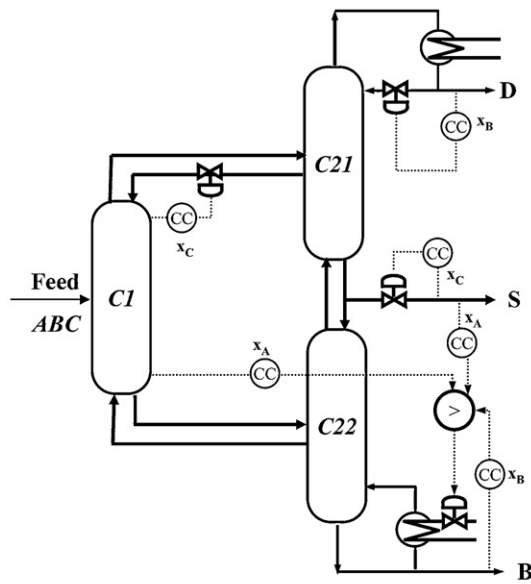

(b) CS4: Max-selector to avoid large x_A in sidestream and in bottom of prefractionator (*Recommended for all feed compositions*).

Fig. 5. Control Structures without use of vapor split (R_V).

3.3.1. Control structure 1 (CS1)

In this structure, we use “Option I” and control the sum of the impurities ($x_A^S + x_C^S$) with the side-product (S). Since the vapor split (R_V) is available for manipulation, we then have two degrees of freedom left and can control both “products” in the prefractionator (see Fig. 4(a)). This will guarantee operating the prefractionator at its preferred split [12]. For control loop pairings, we use the most obvious “close-by” manipulated variables as shown in Fig. 4(a).

This scheme is workable at steady state but performs poorly for some feed disturbances. The reason is that the sign of the initial gain of the molar flow rate of side-product on the two key

impurities is opposite. Depending upon the dominant impurity in the side-product, the input (S)-output ($x_A^S + x_C^S$) relationship will change, making it very difficult to work under transient conditions. We will demonstrate using closed-loop simulations that structure CS1 has poor dynamic response properties to feed composition disturbances and CS1 is therefore *not* recommended.

3.3.2. Control structure 2 (CS2)

In structure CS2, we use “Option II” where we overpurify one of the products. We use the side-product (S) to control the heavy key impurity (x_C^S). This means that the amount of light component, A (x_A^S) is left uncontrolled which is acceptable as long as it is overpurified. However, if x_A^S becomes large then we need to increase the vapor flow in section C21 and instead overpurify the bottom product. To achieve this we pair the boilup (V) with two composition controllers (both x_B^D and x_A^S) and use a max-selector. This means that one of the two products (bottoms or side-product) will be overpurified for any disturbance. However, as explained earlier this will only slightly increase the energy usage (V).

3.3.3. Control structure 3 (CS3)

We also study two structures for the case when the vapor split is not available as a degree of freedom. Control structure CS3 in Fig. 4, has been suggested by Ling and Luyben [18] and a similar control structure was reported by Alstad [2] and Kiss and Rewagad [15]. Since the vapor split is not available for control, the prefractionator column C1 can have only one-point control and the light component (A) at C1 bottoms is left uncontrolled. In the main column, the side-product is paired with the heavy key (C) while the light key (A) in side-product remains uncontrolled. This is acceptable as long as there is little light component A in the side-product (over-purified). As confirmed in the simulations, this structure fails if the feed composition is such that A/B split is the most difficult one.

3.3.4. Control structure 4 (CS4)

This is an improvement of CS3, which is workable also when A/B is the more difficult split. It is based on the same idea as structure CS2, but the boilup now also looks after the amount of A in the prefractionator C1 bottoms. To ensure sufficient vapor flow, we use a maximum-select controller and pair the boilup with the largest boilup resulting from controlling the following three impurities:

1. Component A in bottom of prefractionator (x_A^{B1}).
2. Component A in side-product (x_A^S).
3. Component B in bottom-product (x_B^D).

This implies that two of these compositions will be overpurified at any given time, and it is expected that the energy usage (V) may be large for some disturbances.

4. Closed loop simulation results

The four control structures were simulated for the nominal case, for a $\pm 20\%$ feed rate change and for six feed composition disturbances of which four cases are shown in Figs. 6–9. All the control structures could handle the feed rate disturbance of $\pm 20\%$ but for the feed composition disturbances, some responses using structures CS1 and CS3 were poor.

Nominally, the column is operated at a point where both splits A/B and B/C are “difficult” and none of the products are overpurified. However, for feed composition disturbances, z_1^F , z_2^F and z_3^F , the B/C split is the most difficult one and for feed composition disturbances z_4^F , z_5^F and z_6^F , the A/B split is more difficult. The results of the closed-loop simulations feed rate and all six compositions are

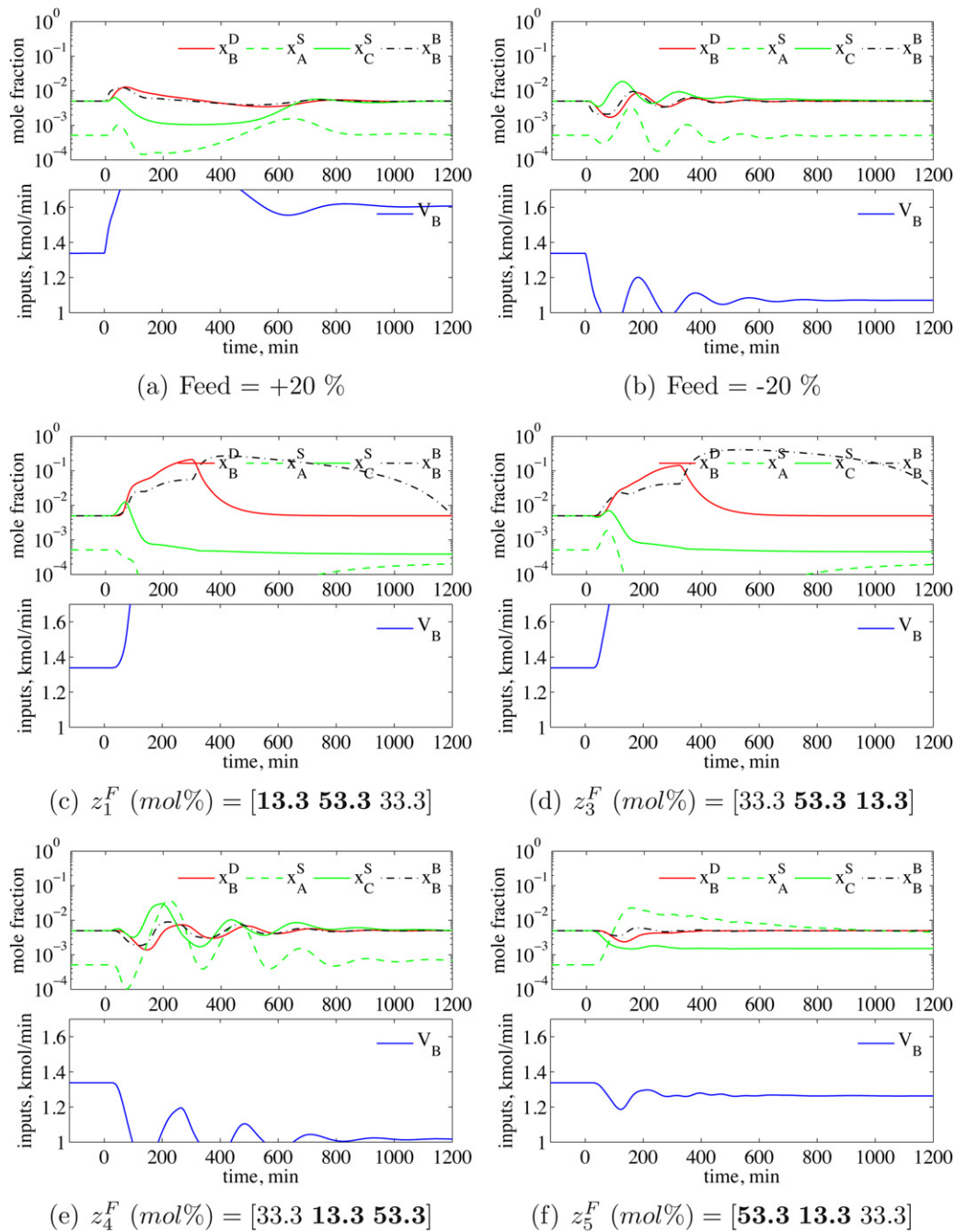

Fig. 6. CS1: closed-loop results for feed rate and composition disturbances (not acceptable for feed composition disturbance z_1^F , z_3^F and z_4^F as the transient response is poor).

summarized in Table 2 and we see that structure CS3 fails when the A/B split is more difficult.

Simple decentralized proportional-integral (PI) controllers with SIMC tuning [25] were used. Step changes in the manipulated variables were made to identify the input–output steady state gain and effective time delay. The SIMC tuning parameter, τ_c was selected to get a smooth response (see Table 3). Note that the tuning was straight forward. The energy loop involving the maximum-select controllers were detuned for a smooth response.

In addition, logarithmic transformations of compositions were used to reduce the effect of non-linearity [26,27]. Therefore, the controlled composition variables are actually $\ln x_i$, where x_i is the key impurity being controlled.

4.1. Simulation of structure CS1

Fig. 6 shows closed-loop responses using CS1 for a $\pm 20\%$ feed rate changes and feed composition disturbances. We use a semi-log scale to plot the compositions of the key impurities in the main products D, S and B. The side-product has two key impurities, A and C. We observe that the closed-loop responses for feed disturbances, z_1^F and z_3^F (Fig. 6(c) and (d)) show poor transient responses. After a long time (not shown in simulations), the impurities are restored to their steady-state values. However, this structure is not recommended, as during the transient conditions, the inputs saturate and there are very large changes in the product compositions.

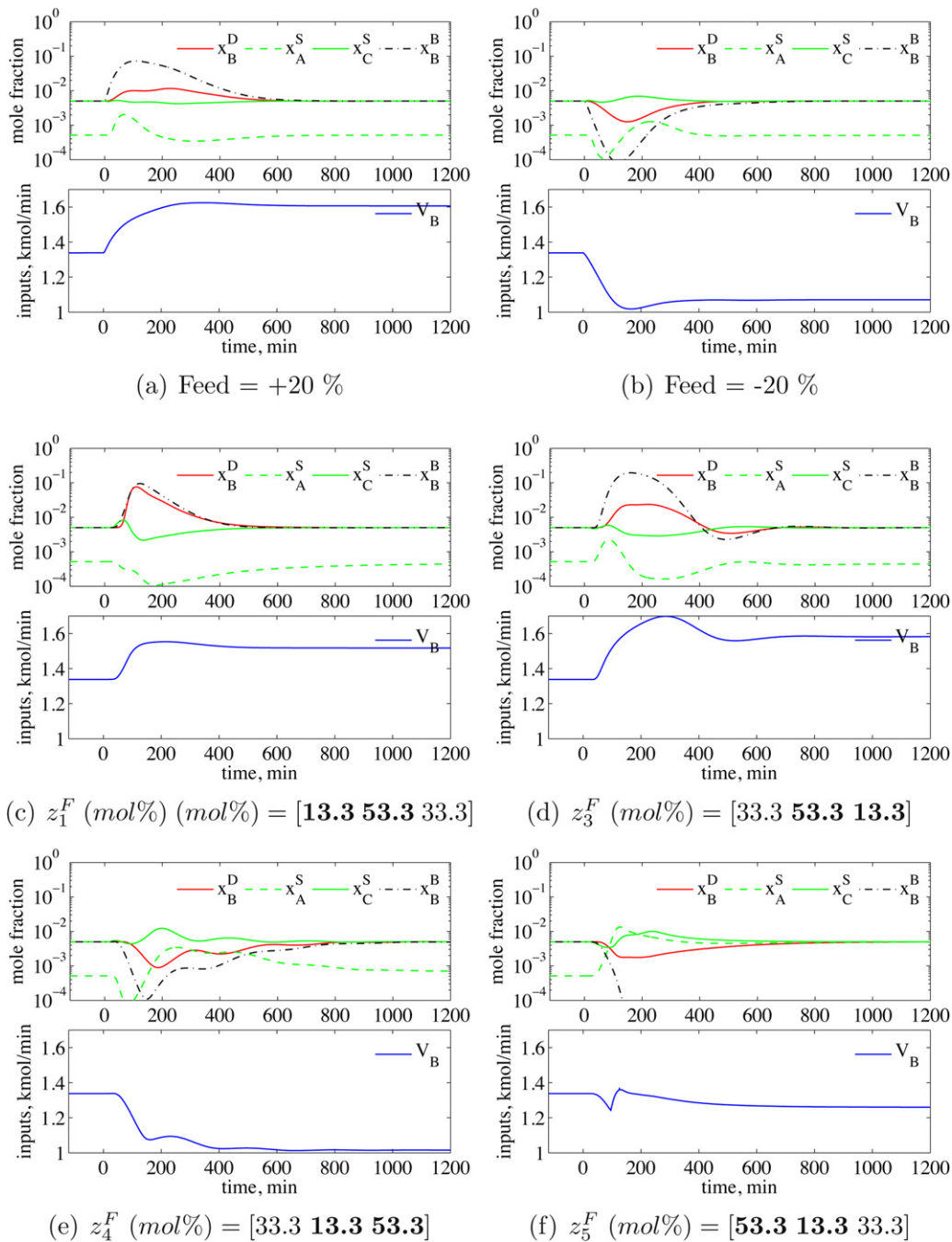

Fig. 7. CS2: closed-loop results for feed rate and composition disturbances (acceptable for all disturbances).

4.2. Simulation of structure CS2

Control structure CS2 shows good dynamic responses for the $\pm 20\%$ feed rate changes and the feed composition disturbances as shown in Fig. 7. The steady state impurities of the products are better than the specifications (3). For feed compositions when the B/C split is more difficult (Fig. 7(c) and (d)), the light impurity (A) in side-product is not controlled and is over-purified. For feed compositions when A/B is the more difficult split, the maximum-select controller pairs the boilup with the light key in side-product and the bottom product is over-purified (Fig. 7(e) and (f)). Note that for

these cases, both key impurities in the side-product are controlled simultaneously.

4.3. Simulation of structure CS3

We next consider the case when the vapor split (R_V) is not a degree of freedom. Control structure CS3 does not attempt to control A in the side product and is workable for cases where B/C is the most difficult split (disturbances z_4^F and z_5^F , see Fig. 8(c) and (d)). However, for disturbances when A/B is the more difficult split (Fig. 8(e) and (f)). We have “breakthrough” of A in the bottom

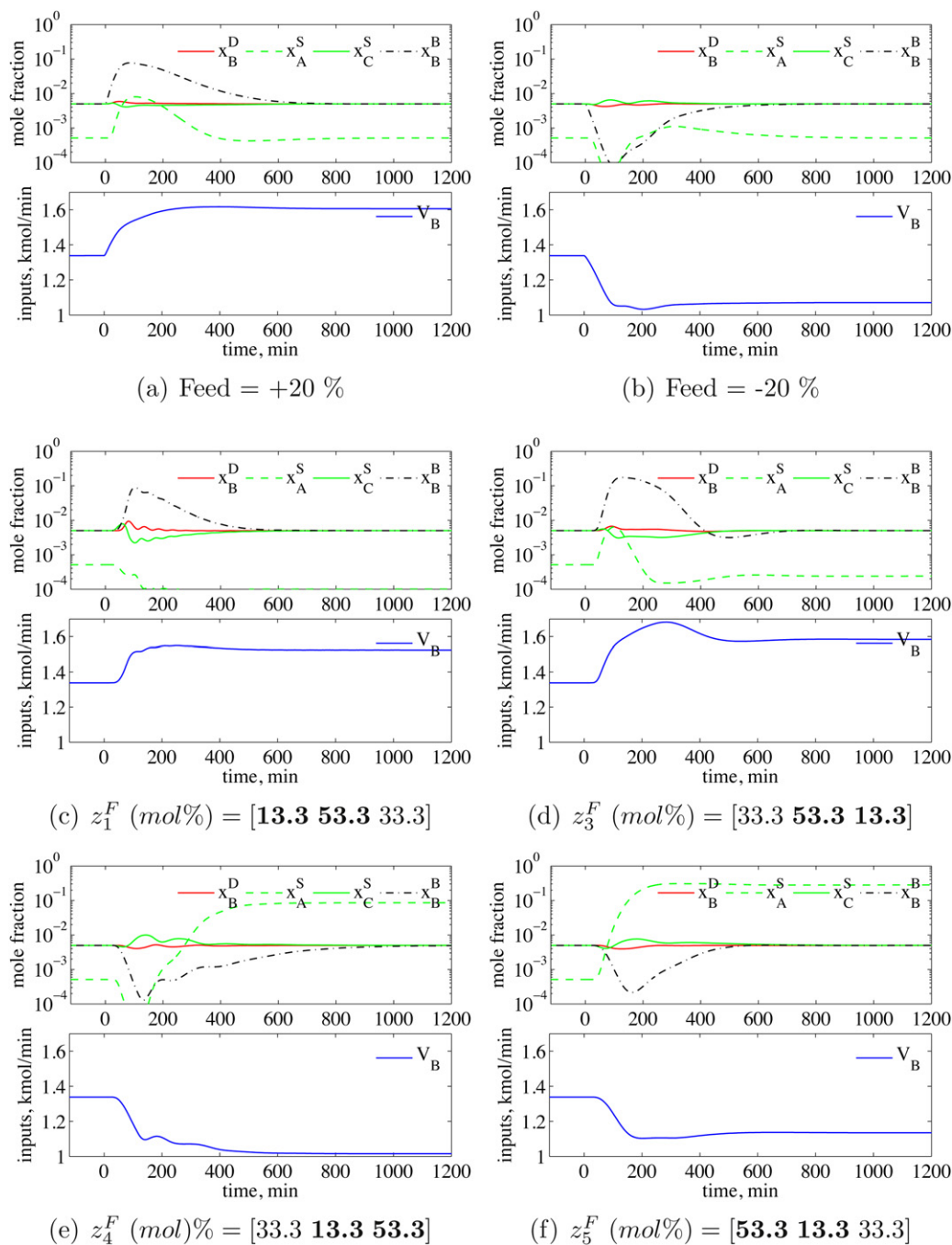

Fig. 8. CS3: closed-loop results for feed rate and composition disturbances (not acceptable for disturbances z_4^F and z_5^F as x_A^S goes out of bounds).

of the prefractionator (see, for example, Fig. 10) and the impurity constraint ($x_A^S, x_C^S < 0.5\%$) is violated both dynamically and at steady-state.

4.4. Simulation of structure CS4

Fig. 9 shows closed-loop responses using control structure CS4. The product purities of all products can be controlled within the constraints (3) at steady state in all cases. When A/B is the more difficult split, the boilup is not paired with the bottom light key and therefore the bottom product is over-purified (Fig. 9(e) and (f)).

5. Analysis of energy usage

We have found in the simulations that control structures CS2 and CS4 give good composition control in all cases, but in addition we want the structures to achieve minimum energy usage, or at least close to minimum energy usage. We have plotted the energy usage (V) in all simulations, but to say how good it is we need to compare with the minimum energy usage for the various feed compositions. This is shown in Table 4 where we compare the steady-state energy usage for control structures CS2 and CS4 with the optimal for each case, that is, with and without the vapor split (R_V) as a degree of freedom, respectively. The results show that control structure CS2 is close to the optimal for all feed

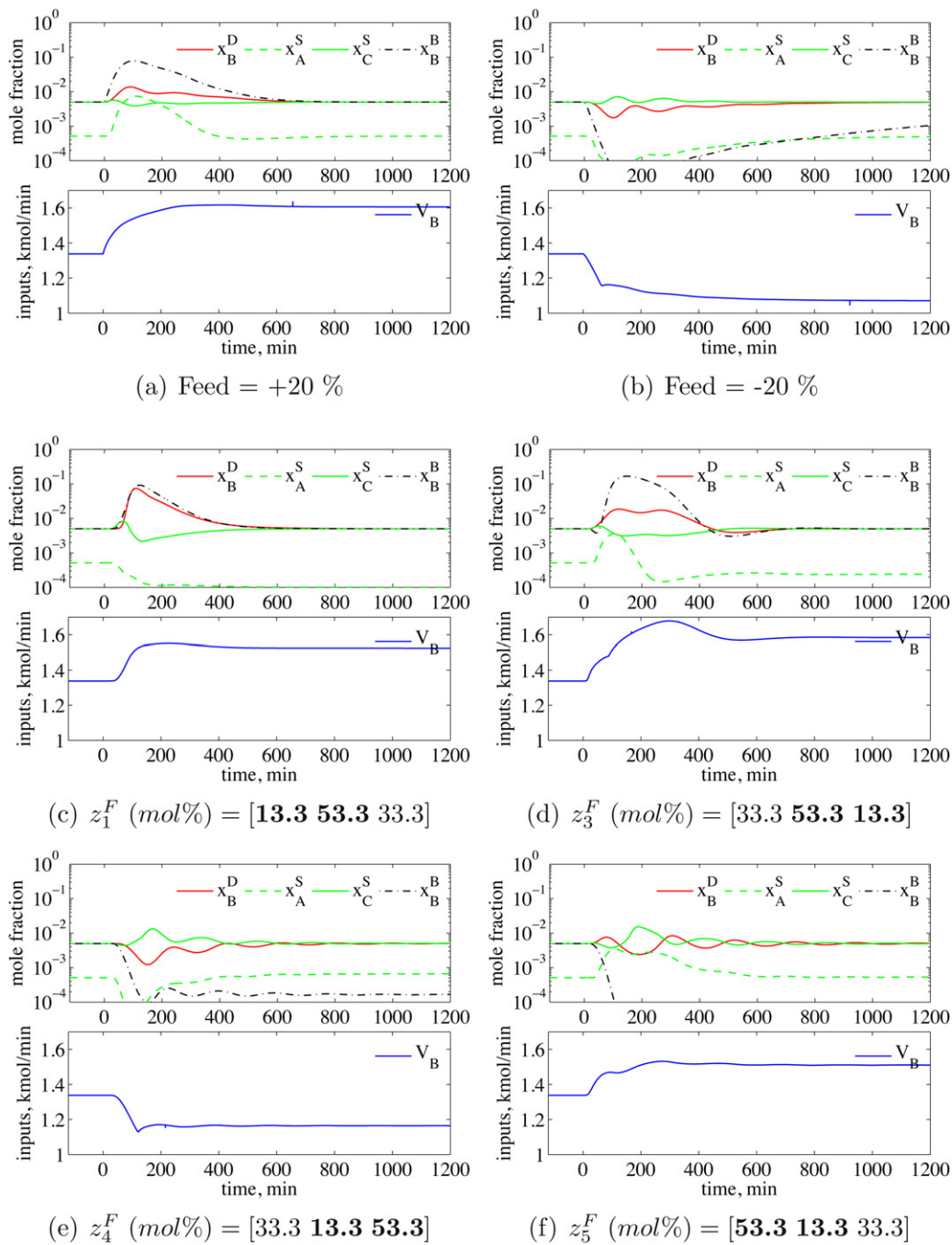

Fig. 9. CS4: closed-loop results for feed rate and composition disturbances (acceptable for all disturbances).

compositions, with a maximum energy loss of 1.01% for feed composition z_6^F . Control structure CS4 is also close to the optimal for all feed compositions, with a maximum energy loss of 2.27% for feed composition z_6^F . Note that the optimal energy usage is generally higher for structure CS4 than for CS2 (up to about 19.88% for z_5^F), but this is an inevitable loss caused by operating with a fixed vapor split (R_V). The reason for the (albeit small) energy losses for control structures CS2 and CS4 is mainly because the prefractionator setpoints in (4b) are not the optimal ones as explained earlier in Section 3.2. This is also why the energy usage is 0.42% above the minimum even for the nominal feed composition.

6. Discussion

6.1. Change in difficult split

Fig. 3 shows how the V_{\min} diagram depends on the feed composition. As explained earlier, the minimum boilup for sharp separation is set by the “most difficult binary split”, which are given in Fig. 3 by the peaks P_{AB} and P_{BC} . For the nominal feed (red solid line), the peak P_{BC} is highest. This implies that the B/C split is more difficult. It is then acceptable to leave A uncontrolled in the side stream as in structure CS3. However, for a feed composition making A/B the more difficult split (blue dashed line in

Table 2
Summary of closed-loop composition responses^{a,b,c,d} using different control structures (superscript numbers refer to corresponding figure numbers).

Disturbance	CS1	CS2	CS3	CS4
Feed, +20%	OK ^{6(a)}	OK ^{7(a)}	OK ^{8(a)}	OK ^{9(a)}
Feed, -20%	OK ^{6(b)}	OK ^{7(b)}	OK ^{8(b)}	OK ^{9(b)}
z_F^F (mol%) = [13.3 53.3 33.3]	Poor ^{6(c)}	OK ^{7(c)}	OK ^{8(c)}	OK ^{9(c)}
z_F^{B1} (mol%) = [13.3 33.3 53.3]	OK	OK	OK	OK
z_F^{B2} (mol%) = [33.3 53.3 13.3]	Poor ^{6(d)}	OK ^{7(d)}	OK ^{8(d)}	OK ^{9(d)}
z_F^{B3} (mol%) = [33.3 13.3 53.3]	Poor ^{6(e)}	OK ^{7(e)}	Fail ^{8(e)}	OK ^{9(e)}
z_F^{B4} (mol%) = [53.3 13.3 33.3]	OK ^{6(f)}	OK ^{7(f)}	Fail ^{8(f)}	OK ^{9(f)}
z_F^G (mol%) = [53.3 33.3 13.3]	OK	OK	Fail	OK

^a OK: closed-loop stable and purities all products are either restored/over-purified and the transient responses are not very severe.

^b Fail: closed-loop stable but purity of side-product is not maintained (x_B^S dropped considerably).

^c Poor: although steady state purities may be restored, the transient response is poor and shows valve saturation.

^d Nominal feed rate: $F=1$ kmol/min. Nominal feed composition, z_F (mol%) = [33.3 33.3 33.3]

Table 3
SIMC tuning parameter (τ_c) used in the four control structures.^{a,b}

Loop	CS1	CS2	CS3	CS4
R_L	10 min	10 min	10 min	40 min
R_V	40 min	40 min	–	–
L	20 min	10 min	10 min	40 min
S	80 min	40 min	40 min	10 min
V_B	10 min	40 and 40 min ^a	40 min	40, 40 and 10 min ^b

^a τ_c for V_B paired with B in reboiler and τ_c for V_B paired with A in side-product respectively.

^b τ_c for V_B paired with B in reboiler, τ_c for V_B paired with A in side-product and τ_c for V_B paired with A in sub-column C1 bottoms respectively.

Fig. 3), the boilup should be increased, for example, using a selector to avoid A in the bottoms of the main column section C21 (A/B split) and as well as bottom of the prefractionator (A/C split, see Fig. 10).

The magnitude of feed composition disturbance in this study is large. However, simulations show that structure CS3 fails and there is a breakthrough of light impurity (A) in the side product also for smaller feed disturbances. The reason is that the nominal operating point is quite close to a region where A/B may become the more difficult split.

6.2. Multivariable control (MPC)

In this work, we have studied performance of decentralized control schemes based on PI-controllers and max-selectors as this is the preferred solution in industry, whenever it is found to be workable. We found that its performance is acceptable, but tuning the controllers was difficult in some cases. Thus, this may be a case where

Table 4
Energy usage at steady state for control structures CS2 and CS4 as compared against optimum energy usage with and without the vapor split (R_V) for different feed composition disturbances.

Disturbance	Boilup (V), kmol/min			
	With R_V		Without R_V	
	Optimal	CS2	Optimal	CS4
z_F^F (mol%) = [13.3 53.3 33.3]	1.5070	+0.7%	1.5072	+1.2%
z_F^{B1} (mol%) = [13.3 33.3 53.3]	1.2528	+0.33%	1.2551	+0.37%
z_F^{B2} (mol%) = [33.3 53.3 13.3]	1.5713	+0.68%	1.5722	+0.76%
z_F^{B3} (mol%) = [33.3 13.3 53.3]	1.0151	+0.06%	1.1434	+1.88%
z_F^{B4} (mol%) = [53.3 13.3 33.3]	1.2571	+0.23%	1.4769	+2.27%
z_F^G (mol%) = [53.3 33.3 13.3]	1.4533	+1.01%	1.6406	+0.87%
z_F (mol%) = [33.3 33.3 33.3]	1.3325	+0.42%	1.3325	+0.42%

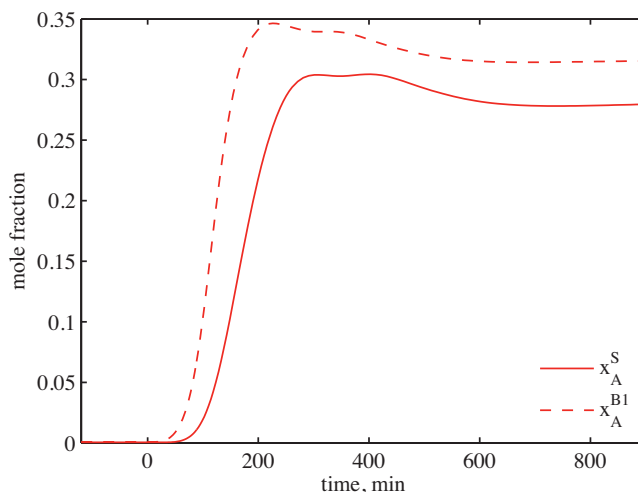

Fig. 10. Failure of control structure CS3 for feed composition disturbance z_F^F (mol%) = [53.3 13.3 33.3] caused by breakthrough of component in bottoms of prefractionator (x_A^{B1}) resulting in contaminated side product (x_A^S).

multivariable control (e.g., MPC) should be considered to reduce interactions and improve performance.

One may think that the max-select controllers can easily be replaced by a constrained multivariable controllers, like MPC. However, a more careful evaluation reveals that this is not so clear, because when we switch using the PI-controllers, we use controllers tuned in different operating regions, for example, with and without A in the side product. Thus, to get acceptable control with MPC, one probably would need to include model information from different operating regions, which may difficult to handle in a conventional linear MPC framework. Possibly, this could be a case where non-linear MPC based on physical models may be the preferred solution.

6.3. Other control structures

In principle, there are many other possible control structures with selectors, in addition to CS2 and CS4, but these have not been studied. To see this, note that we are attempting to control six compositions, which include two for the two “products” in the prefractionator and four for the three products in the main column, see (3) and (4). However, we only have five degrees of freedom for the case when R_V is a manipulated variable, and four degrees of freedom for the case when R_V is fixed during operation, respectively. Thus, we have too few degrees of freedom to control all six compositions and to satisfy the six specifications we need to overpurify some products. For the case when R_V is fixed, we are lacking two degrees of freedom and we propose in control structure

CS4 to always control *three* of the compositions, and to overpurify *two* of the remaining *three* compositions using a selector. However, it is not given which *three* compositions to include in the selector, and it is not given that boilup should be used in the selector. Specifically, for the split A/B we may choose to overpurify x_B^D (B in distillate) rather than x_A^S (A in sidestream), and for the split B/C we may choose to overpurify x_C^S (C in side stream) rather than x_B^B (B in bottom). Similarly, for the prefractionator, we may for the split A/C choose to overpurify x_C in the top rather than x_A in the bottom. Some of these alternatives may be worthwhile considering, in particular, if overpurification of some product is desirable, whenever possible. Nevertheless, of all these possible alternative structures, it seems that structure CS4 is a good choice, mainly because the boilup (V) has a direct effect on the three compositions used by the selector, and because the three remaining manipulated variables have a direct effect on the three remaining compositions. Indeed, it was found to give good composition control with close to minimum energy usage for a wide range of feed composition changes.

7. Conclusions

In this work, we study decentralized control structures when the objective is to achieve desired purities for the three products with close to minimum use of energy (V). For the case where the vapor split (R_V) is a degree of freedom, we propose to use structure CS2 as shown in Fig. 4(a). It will generally lead to overpurification of either the side stream or bottom product, but this will cost very little in terms of extra energy usage. For the more realistic case where the vapor split is not a degree of freedom, the energy usage will be higher for some disturbances. This is inevitable, but otherwise the proposed structure CS4 (see Fig. 5(a)) achieves the desired purities with use of close to minimum energy. The simpler structure CS3 may be used instead of CS4 for cases where the A/B split is relatively simple so that we always have low concentration of A (“overpurification”) in the side stream.

References

- [1] T. Adrian, H. Schoenmakers, M. Boll, Model predictive control of integrated unit operations: control of a divided wall column, *Chemical Engineering and Processing* 43 (3) (2004) 347–355.
- [2] V. Alstad, Studies on selection of controlled variables, Ph.D. thesis, Norwegian University of Science and Technology, Department of Chemical Engineering, 2005 (Chapter 9).
- [3] V. Alstad, I.J. Halvorsen, S. Skogestad, Optimal operation of a Petlyuk distillation column: energy savings by over-fractionating, in: *Escape-14*, Lisbon, Portugal, 2004.
- [4] C. Buck, C. Hiller, G. Fieg, Applying model predictive control to dividing wall columns, *Chemical Engineering & Technology* 34 (5) (2011) 663–672.
- [5] R.P. Cahn, A.G. DiMiceli, Separation of multicomponent mixture in single tower, United States Patent Office, US 3,058,893 (1962).
- [6] A.C. Christiansen, S. Skogestad, Energy savings in complex distillation arrangements: importance of using the preferred separation, in: *AIChE Annual Meeting*, Los Angeles, November 1997, 1997, paper 199d.
- [7] I. Dejanovic, L. Matijasevic, I.J. Halvorsen, S. Skogestad, H. Jansen, B. Kaibel, Z. Olujic, Designing four-product dividing wall columns for separation of a multicomponent aromatics mixture, *Chemical Engineering Research and Design*, 89 (8) (2011) 1155–1167.
- [8] Z. Fidkowski, L. Królikowski, Minimum energy requirements of thermally coupled distillation systems, *AIChE Journal* 33 (4) (1987) 643–653.
- [9] M.S. Govatsmark, S. Skogestad, Selection of controlled variables and robust setpoints, *Industrial & Engineering Chemistry Research* 44 (7) (2005) 2207–2217.
- [10] I.J. Halvorsen, S. Skogestad, Optimal operation of Petlyuk distillation: steady-state behavior, *Journal of Process Control* 9 (5) (1999) 407–424.
- [11] I.J. Halvorsen, S. Skogestad, Minimum energy consumption in multicomponent distillation. 1. V_{\min} diagram for a two-product column, *Industrial & Engineering Chemistry Research* 42 (3) (2003) 596–604.
- [12] I.J. Halvorsen, S. Skogestad, Minimum energy consumption in multicomponent distillation. 2. Three-product Petlyuk arrangements, *Industrial & Engineering Chemistry Research* 42 (3) (2003) 605–615.
- [13] I.J. Halvorsen, S. Skogestad, Minimum energy consumption in multicomponent distillation. 3. More than three products and generalized Petlyuk arrangements, *Industrial & Engineering Chemistry Research* 42 (3) (2003) 616–629.
- [14] G. Kaibel, Distillation columns with vertical partitions, *Chemical Engineering & Technology* 10 (1) (1987) 92–98.
- [15] A.A. Kiss, R.R. Rewagad, Energy efficient control of a BTX dividing-wall column, *Computers & Chemical Engineering* 35 (12) (2011) 2896–2904.
- [16] F. Lestak, R. Smith, V. Dhile, Heat transfer across the wall of dividing wall columns, in: *Trans. Inst. Chem. Eng.*, vol. 72A, 1994, pp. 639–644.
- [17] H. Ling, Z. Cai, H. Wu, J. Wang, B. Shen, Remixing control for divided-wall columns, *Industrial & Engineering Chemistry Research* 50 (22) (2011) 12694–12705.
- [18] H. Ling, W.L. Luyben, New control structure for divided-wall columns, *Industrial & Engineering Chemistry Research* 48 (13) (2009) 6034–6049.
- [19] H. Ling, W.L. Luyben, Temperature control of the BTX divided-wall column, *Industrial & Engineering Chemistry Research* 49 (1) (2010) 189–203.
- [20] M.I.A. Mutalib, R. Smith, Operation and control of dividing wall distillation columns. Part 1: degrees of freedom and dynamic simulation, *Chemical Engineering Research and Design* 76 (3) (1998) 308–318.
- [21] M.I.A. Mutalib, A.O. Zeglam, R. Smith, Operation and control of dividing wall distillation columns. Part 2: simulation and pilot plant studies using temperature control, *Chemical Engineering Research and Design* 76 (3) (1998) 319–334.
- [22] G. Niggemann, C. Hiller, G. Fieg, Experimental and theoretical studies of a dividing-wall column used for the recovery of high-purity products, *Industrial & Engineering Chemistry Research* 49 (14) (2010) 6566–6577.
- [23] F. Petlyuk, V. Platonov, D. Slavinskii, Thermodynamically optimal method for separating multicomponent mixtures, *International Chemical Engineering* 5 (3) (1965) 555–561.
- [24] R.R. Rewagad, A.A. Kiss, Dynamic optimization of a dividing wall column using model predictive control, *Chemical Engineering Science* 68 (1) (2012) 132–142.
- [25] S. Skogestad, Simple analytic rules for model reduction and pid controller tuning, *Journal of Process Control* 13 (4) (2003) 291–309.
- [26] S. Skogestad, The do's and don't's of distillation column control, *Chemical Engineering Research and Design* 85 (1) (2007) 13–23.
- [27] S. Skogestad, M. Morari, LV-control of a high-purity distillation column, *Chemical Engineering Science* 43 (1) (1988) 33–48.
- [28] W. Stupin, Thermally coupled distillation – a case history, *Chemical Engineering Progress* 68 (10) (1972).
- [29] E.A. Wolff, S. Skogestad, Operation of integrated three-product (Petlyuk) distillation columns, *Industrial & Engineering Chemistry Research* 34 (6) (1995) 2094–2103.