

PROCESS DESIGN AND CONTROL

Steady-State Operational Degrees of Freedom with Application to Refrigeration Cycles

Jørgen Bauck Jensen[†] and Sigurd Skogestad*

Department of Chemical Engineering, Norwegian University of Science and Technology, Trondheim, Norway

An important issue for optimal operation and plantwide control is to find the degrees of freedom available for optimal operation. A previously published systematic approach to determine the steady state degrees of freedom is expanded to take into account the active charge as a possible degree of freedom in cyclic processes. Additional degrees of freedom related to the composition of the circulating refrigerant are also discussed. Two liquified natural gas (LNG) processes of current interest, the C3MR process from Air Products and the mixed fluid cascade (MFC) process developed by Statoil-Linde LNG Technology Alliance, are studied with respect to operational degrees of freedom.

1. Introduction

This paper considers degrees of freedom for optimal operation of refrigeration processes. Skogestad¹ points out that it is normally the steady-state that affects the plant economics, so we will consider only steady-state operation. A list of the potential steady-state degrees of freedom for some typical process units is published by Skogestad² with an updated version by Araujo and Skogestad.³ We wish to extend this list to also include degrees of freedom that are special for closed cycles.

Glemmestad et al.⁴ discuss degrees of freedom for heat exchanger networks (HEN). The review paper on plantwide control by Larsson et al.⁵ discusses degrees of freedom as this is an important step in plantwide control. A more recent study on degrees of freedom is that of Konda et al.⁶

Processes for liquefaction of natural gas are very cost intensive and require large amounts of energy in operation. It is therefore important that the plants are both well-designed and later operated close to optimum, also for changing conditions. The optimal design of liquified natural gas (LNG) processes has been studied extensively by several companies such as Air Products, Shell, Phillips, and Statoil-Linde LNG Technology Alliance. It seems, however, that the subsequent operation of LNG plants has been less studied. This is a bit surprising considering the large throughputs which make even small improvements economically attractive. There are some publications regarding control of LNG plants,^{7,8} but they consider the dynamic performance and controllability rather than the optimal steady-state operation. Zaim⁹ looked into dynamic optimization of a plant with several trains in parallel.

Degrees of freedom for refrigeration processes are covered in section 2, and in the last part of the paper, we apply the findings to some case studies, including two LNG processes:

- The propane precooled mixed refrigerant (C3MR) process from Air Products
- The mixed fluid cascade (MFC) process from Statoil-Linde LNG Technology Alliance

* To whom correspondence should be addressed. E-mail: skoge@chemeng.ntnu.no. Tel.: +47 73 59 41 54. Fax: +47 73 59 40 80.

[†] Current affiliation: ABB, Enhanced Operations & Production, Oslo, Norway.

2. Degrees of Freedom

An important issue in plantwide control is to find the degrees of freedom that may be used for economic optimization¹ which in our case is equal to the number of steady-state degrees of freedom N_{ss} . This is an important number for several reasons. First, it determines the degrees of freedom available for solving the optimization problem. However, more importantly in terms of operation, it determines the number of steady-state controlled variables (N_{ss}) that need to be selected. This is because optimal operation is implemented by keeping the selected controlled variables at constant set points.

Rule (Actual Degrees of Freedom). The number of steady-state degrees of freedom (N_{ss}) may be obtained by counting the number of dynamic manipulated variables N_{MV} and subtracting the number of degrees of freedom (N_0) with no steady-state effect, including:^{2,10}

- Manipulated variables with no steady-state effect on the operation, e.g. extra bypasses of heat exchangers (only used to improve dynamic performance)
- Variables with no steady state effect that need to be controlled, e.g. liquid holdups with no steady state effect.

Thus, $N_{ss} = N_{MV} - N_0$.

2.1. Potential (Maximum) Steady-State Degrees of Freedom. Based on the above rule, Skogestad² derived the *potential* number of degrees of freedom N_{ss}^{\max} for some typical process units with an updated version published by Araujo and Skogestad.³ In Table 1, the list is further updated to include also the potential degrees of freedom for cyclic processes.

The additions are shown in italics in the table. First, note that a valve should normally not be counted, unless it affects a pressure that has a steady-state effect. An example of the latter is a choke valve which is installed to lower the pressure, and it has therefore been added explicitly as a degree of freedom in the table. In addition, we have potentially $N_C - 1$ degrees of freedom related to the fluid composition in the cycle. Finally, the active charge in the cycle is a potential degree of freedom. For example, it may change the pressure level. This is explained in more detail below.

2.2. Actual Steady-State Degrees of Freedom. Many designs will have fewer actual degrees of freedom than the potential given in Table 1. For example, a heat exchanger will

Table 1. Potential Steady-State Operational Degrees of Freedom (N_{ss}^{\max}) for Some Typical Process Units

process unit	potential DOF
feed	1 (feed rate)
splitter	number of exit streams - 1
mixer	0
compressor, turbine, pump	1 (work)
adiabatic flash tank	0 ^a
liquid phase reactor	1
gas phase reactor	0 ^a
heat exchanger	1 (bypass or flow)
column (excluding heat exchangers)	0 ^a + number of side streams
valve	0 ^a
choke valve	1
Each closed cycle	
active charge (holdup fluid)	1 ^b
composition of fluid	$N_C - 1^c$

^a Pressure is normally assumed to be given by the surrounding process and is then not a degree of freedom. However, one must add one degree of freedom for each extra pressure that is independently set and which has a steady-state effect (need a manipulated input not already counted, e.g. a valve). ^b The active charge in the equipment is a potential degree of freedom, but it may not be available in some designs. ^c N_C is the number of components in the working fluid (refrigerant).

Potential degrees of freedom

1 Compressor
2 Heat exchangers
1 Choke valve
+ 1 "Active charge"
$N_{ss}^{\max} = 5$ degrees of freedom

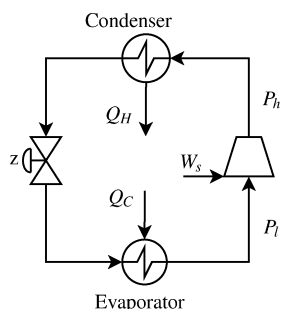
**Figure 1.** Simple refrigeration cycle with $N_{ss}^{\max} = 5$ potential degrees of freedom. However, if the flowsheet shows the actual process there will only be $N_{ss} = 4$ degrees of freedom, because there is no means of changing the active charge for example by filling or removing refrigerant.

not have any degrees of freedom if all flows are given and there is no bypass or other means of affecting the heat transfer. For example, this is usually the case for the main exchanger in a LNG process. Similarly, one may not be able to adjust the total active charge or fluid composition in practice. Nevertheless, knowing the potential (maximum) degrees of freedom is useful for understanding the operation of a given process, and the possible limitations on operation imposed by not having all degrees of freedom.

Example. From Table 1, the simple cooling cycle shown in Figure 1 with a pure refrigerant fluid ($N_C = 1$) has five potential degrees of freedom ($N_{ss}^{\max} = 5$) related to the following: one compressor, two heat exchangers, one choke valve opening (z), and the active charge. Exactly how these degrees of freedom may be changed in practice depends on the case. For example, for a compressor, the actual manipulated variable (MV) is typically the rotational speed or the fraction of time the compressor is on (home or automotive installations). The active charge in Figure 1 may be changed by filling or removing refrigerant to the cycle, but since this possibility is not included, the actual process does not have a degree of freedom related to the active charge and thus has only 4 degrees of freedom ($N_{ss} = 4$).

2.3. Remark on Active Charge or "Feed" for Closed Cycles. The active charge is defined as the total mass accumulated in the process equipment in the cycle, mainly in the

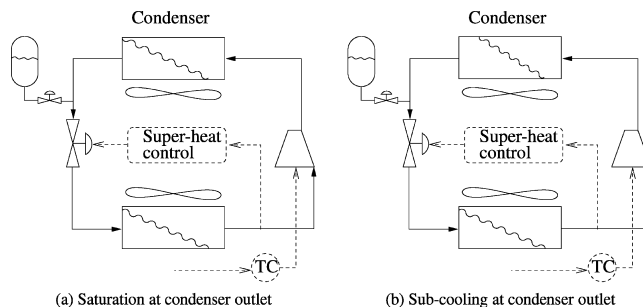
**Figure 2.** Simple (not closed) refrigeration cycle. The external filling/emptying system illustrates the degree of freedom related to the active charge.**Table 2. Actual Steady-State Degrees of Freedom for Refrigeration Cycles, $N_{ss} = N_{MV} - N_0$**

process unit	actual DOF
Each MV (valve, heat exchanger, compressor, turbine etc.)	1
For each cycle subtract variables with no steady-state effect (N_0):	
pure fluid liquid receivers exceeding the first ^a	-1
multicomponent liquid receiver exceeding the N_C first ^b	-1

^a The first receiver is not subtracted in a closed cycle as this has a steady state effect. ^b The number of degrees of freedom is less if the N_C first receivers does not have different compositions.

condenser and evaporator, but excluding any adjustable mass in liquid receivers (tanks).¹¹

The degree of freedom related to the total active charge is not obvious, so we here discuss this "extra" degree of freedom that may occur in closed cycles. Consider the closed process shown in Figure 2 with five degrees of freedom: (1) We have included an external tank with a valve for filling refrigerant into the closed cycle to change the active charge. (2) A temperature controller adjusts the compressor speed to ensure that the cooling load is constant. (3) The choke valve is a thermostatic expansion valve (TEV) that controls the degree of superheating at the evaporator outlet. (4, 5) The heat transfer in the heat exchangers can be adjusted by the fan speed, and we here assumed fixed fan speeds (e.g., at maximum).

To understand the effect of active charge, assume first that the process is operated with just enough charge (refrigerant in the closed cycle) to obtain saturation out of the condenser; see Figure 2a. We then open the external valve for some time and then close it again to fill more refrigerant into the cycle. We then get to the operating condition shown in Figure 2b where the added amount of refrigerant has accumulated in the condenser. This follows since the evaporator will not change its holdup (significantly) due to the thermostatic expansion valve that indirectly sets the area available for superheating so the only place the extra refrigerant can go is to the condenser. The increased charge in the condenser will lead to a higher pressure P_h , which again leads to larger mean temperature difference and thus more heat transfer, and the liquid at the outlet from the condenser will be subcooled, as illustrated in Figure 2b. It has been shown that this may reduce the necessary compressor power in some cases,¹¹ but the main point here is to note that the charge in the system has an effect on the steady state operation.

Remark 1. Note that Table 2 discussed below does not apply because the cycle in Figure 2 is not closed.

Remark 2. If we add a liquid receiver to the cycle in Figure 2, then we lose one degree of freedom (as we have a level with no steady-state effect that needs to be controlled). To regain this degree of freedom we would need to add another valve.

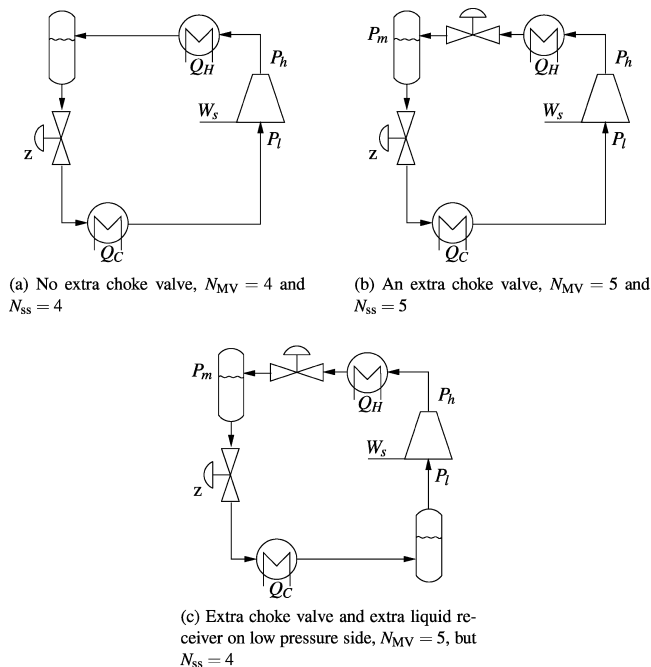

Figure 3. Simple cycle with liquid receiver on the high pressure side.

2.4. Actual Degrees of Freedom for Refrigerant Cycles.

For a closed cycle, in order to adjust the active charge during operation we need a liquid receiver (variable holdup) in the cycle. However, for a pure refrigerant adding additional (two or more) receivers will not increase the number of degrees of freedom, as the holdup has no steady-state effect and needs to be controlled (actually, it may reduce the number unless we also add a valve for this purpose). In general, for a multicomponent (mixed) refrigerant, the holdup of the N_C first tanks *do* have a steady-state effect provided the tanks have different compositions, as they provide an indirect means of adjusting the fluid composition. Only liquid receivers exceeding the N_C first will have no steady-state effect. These arguments are the basis for Table 2 which gives the actual (rather than the potential in Table 1) degrees of freedom for closed vapor compression cycles.

Let us apply Table 2 to the process in Figure 1 which has $N_{MV} = 4$ (two heat exchangers, one valve, and one compressor). Since there are no liquid receivers, there are no variables that need to be subtracted ($N_0 = 0$). Thus, $N_{ss} = 4$ degrees of freedom, which confirms our earlier findings.

Note that adding a liquid receiver somewhere in this cycle will not change the number of steady-state degrees of freedom. In order to change the number of degrees of freedom, we also need to add a valve, for example upstream of the receiver. The addition of a liquid receiver to the cycle is shown in Figure 3. We have from Table 2 the following degrees of freedom for the three cases in Figure 3:

Figure 3(a)	Figure 3(b)	Figure 3(c)
$N_{MV} = 4$	$N_{MV} = 5$	$N_{MV} = 5$
$-N_0 = 0$	$-N_0 = 0$	$-N_0 = 1$
$N_{ss} = 4$	$N_{ss} = 5$	$N_{ss} = 4$

For the two first cases, the liquid level does not need to be subtracted as it has a steady-state effect (see Figure 2) and also does not need to be controlled in a closed cycle.

The design in Figure 3a with no extra valve always gives saturation at the condenser outlet. The design in Figure 3b with an extra choke valve has an additional degree of freedom. This

may be more optimal¹¹ since it allows for the condenser outlet to be subcooled. This is because the pressure in the receiver is equal to the saturation pressure and the extra valve gives $P > P_{sat}$ (subcooling) at the condenser outlet.

In Figure 3c, we have added also a liquid receiver on the low pressure side. Since the flow leaving the tank is saturated vapor, this guarantees that the compressor feed is always vapor. However, by adding the tank we have lost one degree of freedom compared to Figure 3b, because one of the liquid levels need to be controlled. Another way of understanding why there is one less degree of freedom is that we now always have saturated vapor at the inlet to the compressor, whereas it before could be superheated or even contain liquid.

Remark. Note that a loss of a degree of freedom does not mean that the process is less optimal. In fact, in this case it is opposite, because for a simple cycle (without internal heat exchange) it is optimal to have saturation (no superheating) before the compressor. Thus Figure 3c is optimal by design, whereas in Figure 3b one needs to adjust one of the degrees of freedom to get optimality, and this may be difficult to achieve in practice.

3. Case Studies

We will here present some more complex case studies. First we look at two processes that are not directly related to LNG plants: a two-pressure level refrigeration cycle and a heat integrated distillation column (two different configurations). Then, we will consider three LNG case studies: a small scale LNG process with a single mixed refrigerant, the propane precooled mixed refrigerant (C3MR) process from Air Products, and the mixed fluid cascade (MFC) process from Statoil-Linde LNG Technology Alliance.

3.1. Two-Pressure Level Refrigeration. Figure 4a shows a refrigeration system with two-stage expansion using a pure refrigerant ($N_C = 1$). The process stream is first cooled by the intermediate-pressure refrigerant (evaporator 1) and then by the low-pressure refrigerant (evaporator 2). The evaporators are kettle type boilers so there is no superheating of the vapor. The temperature profile in the evaporators is illustrated in Figure 4b. Control of such cycles is discussed by Wilson and Jones.¹² The two compressors are usually driven with a common driver, so there is only one manipulated variable for the two compressors (1). There are three valves, (2), (3) and, (4), shown in Figure 4a. The valve between evaporator 1 and the second compressor, (4), is present to limit the amount of cooling in evaporator 1 if necessary. In addition, we may manipulate the flow of coolant in the condenser (5) and the process stream (6). Thus, this two-pressure level cycle has $N_{MV} = 6$ manipulated variables.

The two evaporators in Figure 4a will function as liquid receivers so there are in total three variable liquid levels. Two of the liquid levels, typically the evaporators, need to be controlled to avoid emptying or overflowing, and since the refrigerant is pure, the set points for these (levels) has no steady-state effect (see also Table 2) (at least if the level is sufficiently high such that all the heat-transfer area is being utilized). Thus, we end up with $N_{ss} = N_{MV} - N_0 = 6 - 2 = 4$ steady-state degrees of freedom. To operate the system, we need to decide on four controlled variables (in addition to the two levels). In general, these should be selected as the active constraints (e.g., max cooling, (5) fully open) plus “self-optimizing” variables for the remaining unconstrained degrees of freedom.

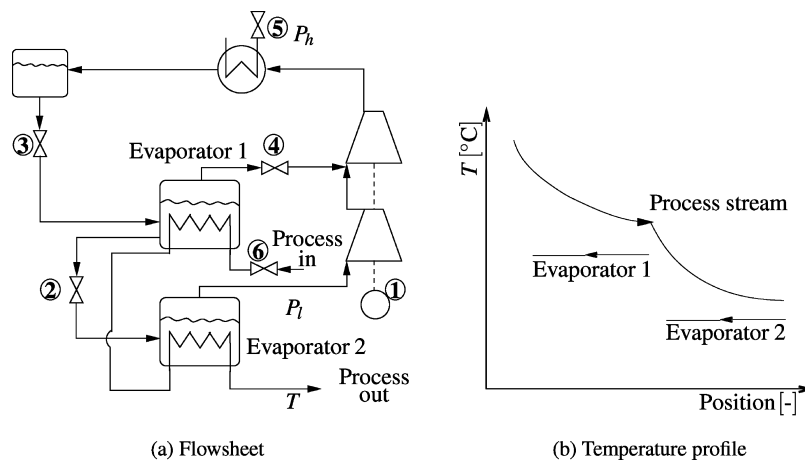

Figure 4. Cooling at two pressure levels, $N_{ss} = 4$.

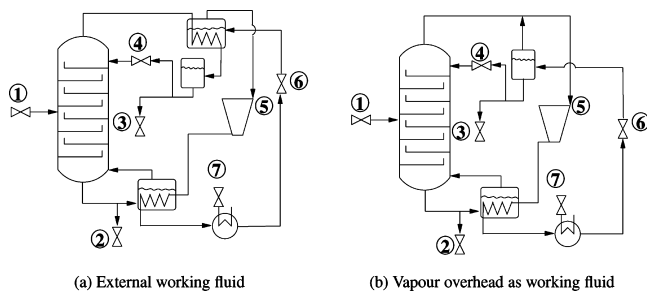

Figure 5. Two ways of using a heat pump to integrate the reboiler with the condenser in a distillation column.

It is interesting to compare the *actual* degrees of freedom with the *potential* degrees of freedom according to Table 1. We have for Figure 4a:

Actual DOF	Potential DOF
$N_{MV} = 6$	1 Feed
$-N_0 = 2$	1 Compressors
$N_{ss} = 4$	3 Heat exchangers
	3 Valve
	+ 1 Active charge
	$N_{ss}^{max} = 9$ degrees of freedom

The 5 “lost” degrees of freedom are related to:

- 1 No subcooling in the condenser (not optimal)
- 2,3 No superheating in the two evaporators (optimal)
- 4,5 No bypasses for the two evaporators (optimal)

Thus, four of the five lost degrees of freedom are “optimal by design” in this case. The only possible loss is related to not allowing for subcooling of the stream leaving the condenser. To fix this would require an additional valve between the condenser and the liquid receiver.

3.2. Heat Integrated Distillation. To reduce the energy consumption in distillation, one may use a heat pump between the condenser and the reboiler.¹³ Two possible designs are shown in Figure 5.

(a) With external working fluid. Control of such columns have been studied by Jørgensen and co-workers^{14–17} who also have an experimental setup.

(b) With the vapor overhead as working fluid (not a closed cycle).¹⁸

There are in total 7 manipulated variables for both systems (see Figure 5): feed flow rate (1), bottom product flow rate (2), top product flow rate (3), reflux flow rate (4), compressor (5), choke valve (6), cooling water flow rate (7).

On the column side, there are two liquid levels with no steady-state effect that must be controlled:

- Condenser liquid level (e.g., may be controlled by the reflux flow rate (4))
- Reboiler liquid level (e.g., may be controlled by the bottom product flow rate (2))

Using the method in Table 2 combined with the general rule we get the actual steady-state degrees of freedom:

Figure 5(a)

$$\begin{array}{r} N_{MV} = 7 \\ -N_0 = 2 \\ \hline N_{ss} = 5 \end{array}$$

Figure 5(b)

$$\begin{array}{r} N_{MV} = 7 \\ -N_0 = 2 \\ \hline N_{ss} = 5 \end{array}$$

Thus, in both cases there are five steady-state degrees of freedom when the feed rate and column pressure are included. This is one more than for an “ordinary” distillation column.

Govatsmark¹⁹ studied the process with external working fluid (Figure 5a) and found that the top composition and the column pressure are optimally at their constraints for the case where the top product is the valuable product. Assuming a given feed flow rate, there are then two unconstrained degree of freedom left. These unconstrained degrees of freedom could then be used to control the following: (1) a temperature in the bottom section of the column, which is found to be a good self-optimizing controlled variable¹⁹ and (2) the degree of subcooling before the choke valve, which has also been shown to be a good self-optimizing controlled variable.¹¹ Alternatively, the common design with zero subcooling before the choke valve may be utilized.

It is interesting to compare the *actual* degrees of freedom with the *potential* (maximum) degrees of freedom according to Table 1:

Figure 5(a)

$$\begin{array}{r} 1 \text{ Feed} \\ 0 \text{ Column} \\ 1 \text{ Pressure (in column)} \\ 1 \text{ Compressor} \\ 3 \text{ Heat exchanger} \\ 1 \text{ Choke valve} \\ + 1 \text{ Active charge} \\ \hline N_{ss}^{max} = 8 \text{ degrees of freedom} \end{array}$$

Figure 5(b)

$$\begin{array}{r} 1 \text{ Feed} \\ 0 \text{ Column} \\ 1 \text{ Pressure (in column)} \\ 1 \text{ Compressor} \\ 2 \text{ Heat exchanger} \\ 1 \text{ Choke valve} \\ + 1 \text{ Pressure (in condenser)} \\ \hline N_{ss}^{max} = 7 \text{ degrees of freedom} \end{array}$$

In Figure 5a, the three lost degrees of freedom are related to:

- 1,2 No bypasses of two heat exchangers (optimal)
- 3 No superheating (saturation) before the compressor (optimal)

From Table 2

$$N_{MV} = 6$$

$$-N_0 = 0^*$$

$$N_{ss} = 6$$

*No subtraction of liquid receivers because of multicomponent working fluid with $N_C \geq 2$

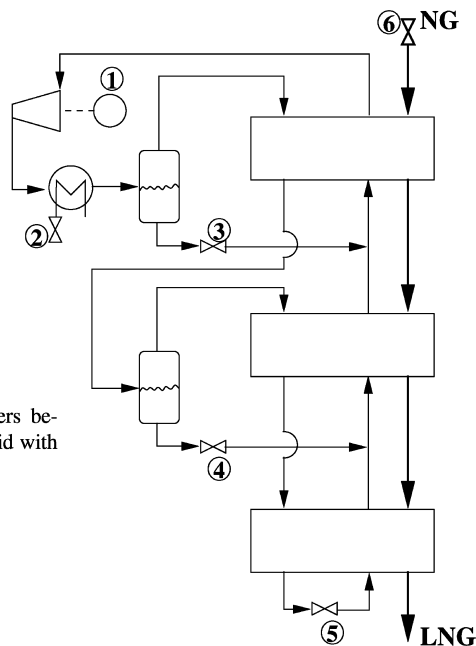

Figure 6. Small-scale LNG concept to illustrate the degrees of freedom related to changing the composition via liquid levels.

For Figure 5b, the two lost degrees of freedom are related to:

- 1 No bypass of the column reboiler (optimal)
- 2 Saturation before compressor (optimal)

Thus, all the lost degrees of freedom in Figure 5 are optimal by design.

3.3. Small-Scale LNG Process. Consider a small-scale LNG process²⁰ with a mixed refrigerant ($N_C \geq 2$) shown simplified in Figure 6. Note that the original process design has additional degrees of freedom related to individual heat exchangers for refrigerant cooling and natural gas cooling. Our simplified flowsheet assumes that it is optimal to cool the refrigerant and the natural gas to the same temperature. We find (using Table 2) that the process has six manipulated variables, $N_{MV} = 6$; see Figure 6. Since there are two liquid levels, we need to control at least one for stabilization. Thus, it is tempting to remove one degree of freedom. However, the level set point has a steady-state effect, because the composition in the two tanks are different and we may change the composition of the circulating refrigerant by shifting mass from one tank to the other. Thus, $N_{ss} = N_{MV} = 6$.

Using Table 1 we get the potential degrees of freedom if we assume $N_C = 3$:

Figure 6

- 1 Feed
- 1 Compressor
- 3 Choke valve
- 4 Heat exchanger
- 1 Active charge
- 2 Compositions

$$N_{ss}^{\max} = 12 \text{ degrees of freedom}$$

We have the following 6 lost degrees of freedom:

- 1–3 No bypasses of process heat exchangers (optimal)
- 4,5 No valves to adjust pressure in the two flash drums (optimal, discussed below)
- 6 No possibility to adjust composition of the refrigerant (not optimal)

The lost degrees of freedom related to the pressures in the two flash drums are not obvious. Adding a valve before the

second flash drum will give a lower temperature in the flash drum and thus also of the vapor that is sent through the second heat exchanger. This is not optimal since the vapor will then be colder than the natural gas which it is cooled together with. The same is true for the first flash drum if the natural gas feed is cooled with the same coolant as the refrigerant after compression.

3.4. Propane Precooled Mixed Refrigerant (C3MR). The C3MR process developed by the Air Products company has a large market share of the existing liquefaction plants worldwide. A flowsheet of the C3MR process is given in Figure 7. The first cycle is with a pure refrigerant, usually propane. The second cycle contains a mixed refrigerant. A good overview of the process as well as different options is given by Newton et al.²¹

We identify the following 13 manipulated variables ($N_{MV} = 13$):

- Natural gas feed (1)
- Six choke valves for propane precooling (one for each pressure level for natural gas cooling and one for each pressure level for mixed refrigerant cooling) (2)–(7)
- Propane compressors, one common speed (8)
- Flow of cooling water or air in propane condenser (9)
- Two choke valves for mixed refrigerant cycle (10) and (11)
- Mixed refrigerant compressor (12)
- Flow of cooling water or air in mixed refrigerant cooler (13)

For the propane cycle, we need to control six of the seven liquid levels (e.g., the heat exchanger levels) and since $N_C = 1$, none of these level set points will have a steady-state effect. Assuming $N_C = 3$ for the mixed refrigerant cycle, we get the following actual and potential degrees of freedom:

Actual DOF

$$N_{MV} = 13$$

$$-N_0 = -6$$

$$N_{ss} = 7$$

Potential DOF

1 Feed

2 Compressor

10 Heat exchanger

8 Choke valve

2 Active charge

+ 2 Compositions (MR)

$$N_{ss}^{\max} = 25 \text{ degrees of freedom}$$

The 18 lost degrees of freedom are related to:

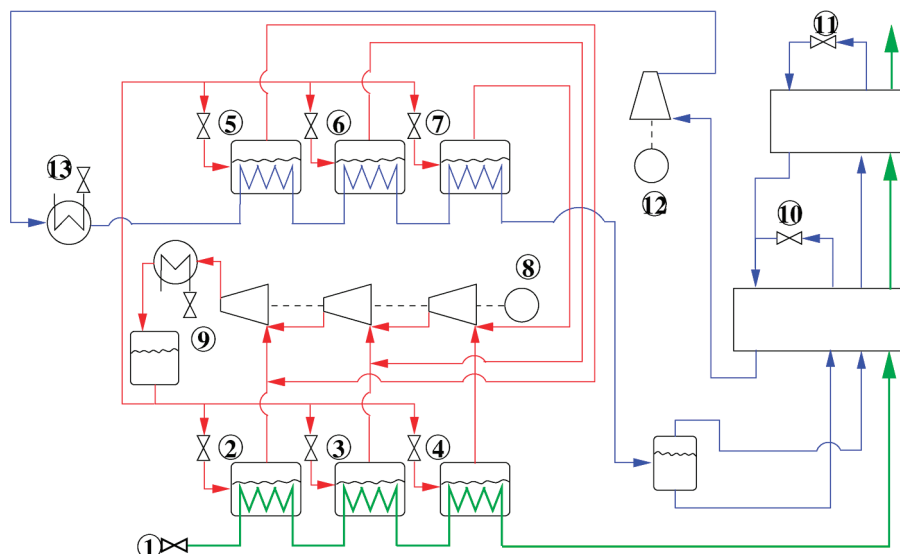

Figure 7. Flowsheet of the C3MR process: propane (C3; red), mixed refrigerant (MR; blue), natural gas (NG; green).

- 1–8 No bypasses of process heat exchangers (optimal)
 9–14 No superheating (saturation) at propane compressor inlet (optimal)
 15 No subcooling (saturation) out of propane condenser (not optimal)
 16 No valve to adjust pressure in the flash drum in the MR cycle (optimal)
 17,18 Not possible to adjust composition of the mixed refrigerant (not optimal)

The only loss in efficiency due to the lost degrees of freedom are caused by having no subcooling in the propane condenser and by not being able to change the composition in the mixed refrigerant cycle. To get subcooling in the condenser, it is necessary to have a valve between the condenser and the liquid receiver. Adjusting the composition is discussed further in section 4.

It is optimal to have the flash drum in the mixed refrigerant cycle at the same pressure as the outlet from the last propane cooler. Otherwise the warm refrigerant would be colder than the natural gas in the first mixed refrigerant heat exchanger, causing a nonoptimal temperature profile.

Optimal Operation. Let us consider two different operating strategies:

Case 1 Maximum production given available shaft work.

Case 2 Minimum shaft work given feed flow rate.

For both cases the following is true:

It is not economical to cool more than necessary, so the natural gas outlet temperature is at its maximum constraint. This temperature will implicitly set the amount of flash gas and may be controlled by the last choke valve in the mixed refrigerant cycle, removing one degree of freedom. Another solution is to use the natural gas feed flow rate by adjusting the LNG expansion. This expansion device (valve or turbine) is not shown here, as we have indicated the feed manipulator at the inlet of the stream instead. Cooling water is usually cheap so it is usually optimal to maximize the flow of cooling water which removes two additional degrees of freedom. We are then left with four degrees of freedom to optimize the operation.

For Case 1. Two degrees of freedom are used to maximize compressor shaft work, one for each cycle (active constraints). This leaves us with two unconstrained degrees of freedom, so two set points must be specified for this case (e.g., P_h in the mixed refrigerant cycle and P_l in the propane cycle)

For Case 2. The feed flow rate is given so we lose one degree of freedom. This leaves us with three unconstrained degrees of freedom, so three set points must be specified for this case (e.g., P_l and P_h in the mixed refrigerant cycle and P_l in the propane cycle).

Remark. If the cooling water is too cold, it may be necessary to limit the flow of cooling water to avoid violating constraints on the compressor suction pressure (minimum constraint). This, however, does not change the analysis since the number of active constraints are the same since we exchange the maximum cooling constraint with the minimum pressure constraint.

3.5. Mixed Fluid Cascade (MFC). The Statoil-Linde LNG Technology Alliance has developed a mixed fluid cascade (MFC) process. A flowsheet of the process is given in Figure 8.^{22,23} It consists of three refrigeration cycles: (i) precooling cycle (PR), (ii) liquefaction cycle (LC), and (iii) subcooling cycle (SC). All three refrigeration cycles use mixed refrigerants.

There are in total 13 manipulated variables ($N_{MV} = 13$):

- Natural gas feed (1)
- Flow of cooling water/air in PC cycle (2)
- Choke valve intermediate pressure level PC cycle (3)
- Choke valve low pressure level PC cycle (4)
- Compressor PC cycle (5)
- Flow of cooling water/air in LC cycle (6)
- Extra valve LC cycle (7)
- Choke valve LC cycle (8)
- Compressor LC cycle (9)
- Flow of cooling water/air in SC cycle (10)
- Extra valve SC cycle (11)
- Choke valve SC cycle (12)
- Compressor SC cycle (13)

There are no liquid levels that must be controlled ($N_0 = 0$). Assuming $N_C = 3$ for each cycle, we get the following actual and potential degrees of freedom:

$$\begin{array}{l} \text{Actual DOF} \\ N_{MV} = 13 \\ -N_0 = 0 \\ \hline N_{ss} = 13 \end{array}$$

$$\begin{array}{l} \text{Potential DOF} \\ 1 \text{ Feed} \\ 3 \text{ Compressor} \\ 7 \text{ Heat exchangers} \\ 4 \text{ Choke valve} \\ 3 \text{ Active charge} \\ + 6 \text{ Composition} \\ \hline N_{ss}^{\max} = 24 \text{ degrees of freedom} \end{array}$$

The 11 lost degrees of freedom are related to:

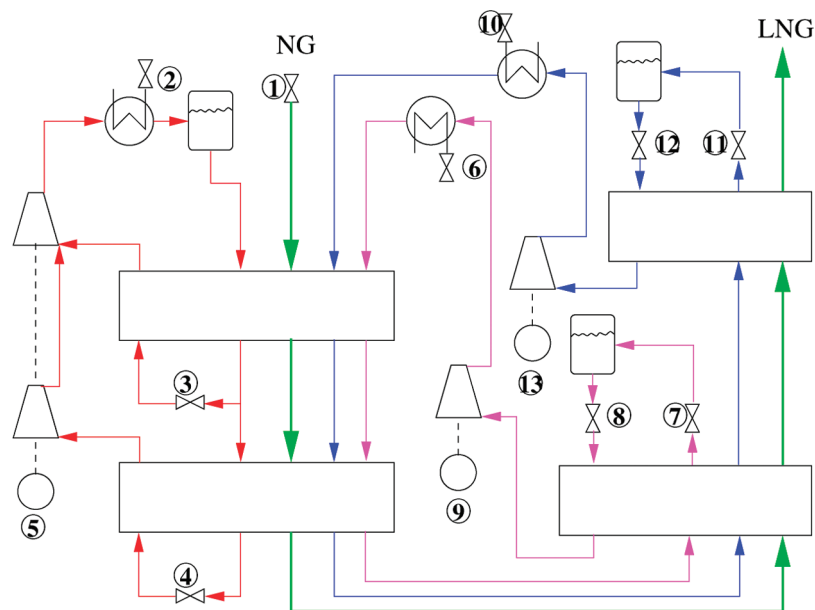

Figure 8. Flowsheet of the MFC process: precooling cycle (PC; red), liquefaction cycle (LC; pink), subcooling cycle (SC; blue), and natural gas (NG; green).

- 1–4 No bypasses of process heat exchangers (optimal)
- 5 No subcooling (saturation) at PC condenser outlet (not optimal)
- 6–11 Not possible to adjust two compositions for each of the three cycles (not optimal)

Also for this process, the saturation specification out of the condenser for the first cycle and the fixed compositions give losses.

Optimal Operation. Let us again consider optimal operation for the two cases of maximum and given feedrate. The LNG outlet temperature must be controlled and the cooling in three seawater coolers should be maximized, giving nine remaining degrees of freedom.

Case 1 (Maximum Feed). We use three degrees of freedom to maximize the compressor shaft work in each cycle. We are then left with six unconstrained degrees of freedom, so six set points must be specified.

Case 2 (Given Feed). The feed is given so there are then eight unconstrained degrees of freedom. For this case, we need eight set points.

Note that there may be active constraints on the temperature after PCHX1 and/or the temperature after PCHX2 if the NGL extraction is integrated. For each active constraint we get one less unconstrained degree of freedom that we have to find a controlled variable for.

4. Discussion

4.1. Degrees of Freedom. In practice, use of Table 1 to find the potential steady-state degrees of freedom may be difficult. This is mainly because an intermediate pressure may or may not have a steady-state effect. This is not easily captured by simply counting the degrees of freedom for each unit operation, because it requires good process understanding. In any case, the method shown in Table 1 is only one of several alternatives that should lead to the same result.

4.2. Refrigerant Composition. For mixed refrigerants there are $N_C - 1$ potential degrees of freedom related to the composition of the refrigerant. However, all of these are usually not realized as actual degrees of freedom. We have claimed above that liquid level set points (provided different composi-

tion) may be used to effectively utilize the degrees of freedom related to refrigerant composition; see the small scale LNG process presented above. This is usually not a practical solution for refrigerants with more than two compositions as it is necessary with equally many liquid tanks (with sufficiently different compositions) and control elements (valves). So in practice, one will instead rely on a constant composition that may be changed on a longer time scale by utilizing the makeup system.

4.3. Saturation in Condenser. Another potential degree of freedom that is sometimes lost is related to the condenser pressure. By having a liquid receiver after the condenser, it will not be possible to have a condenser pressure different from the saturation pressure ($P_{con} = P_{sat}$). By having a valve in between the condenser and the liquid receiver, it is possible to have subcooling in the condenser ($P_{con} \geq P_{sat}$). This is discussed in more detail elsewhere.¹¹ However, it may also be necessary with a different condenser design if the design does not allow for subcooling. This is the case if the liquid formed in the condenser leaves the heat transfer zone (e.g., due to gravity).

5. Conclusion

The steady-state degrees of freedom available for optimization (N_{ss}) is an important number for several reasons. First, it determines the number of free variables available to solve the optimization problem. However, more importantly it determines how many steady-state controlled variables that must be selected to operate the process.

This paper extends an earlier published simple approach to determine the potential degrees of freedom (N_{ss}^{max}) based on unit operations to also cover vapor compression cycles. A simple method to determine the actual degrees of freedom (N_{ss}) for vapor compression cycles is also presented. Both methods are illustrated on four case studies where the difference between the potential and actual degrees of freedom are explained and related to the process layout.

For the two LNG case studies (C3MR and MFC), we also illustrate the effect of operating strategy (maximum production and given production) on the number of unconstrained degrees of freedom.

Literature Cited

- (1) Skogestad, S. *J. Process Control* **2000**, *10* (5), 487–507.
- (2) Skogestad, S. Plantwide control: towards a systematic procedure. In *European Symposium on Computer Aided Process Engineering (ESCAPE)- 12*; The Hague: The Netherlands, May 26–29, 2002.
- (3) Araujo, A.; Govatsmark, M.; Skogestad, S. *Control Eng. Practice* **2007**, *15*, 1222–1237.
- (4) Glemmestad, B.; Skogestad, S.; Gundersen, T. *Comput. Chem. Eng.* **1999**, *23*, 509–522.
- (5) Larsson, T.; Skogestad, S. *Model., Identific. Control* **2000**, *21*, 209–240.
- (6) Konda, N.; Rangaiah, G.; Krishnaswamy, P. *Chem. Eng. Sci.* **2006**, *61*, 1184–1194.
- (7) Mandler, J. A. *J. Process Control* **2000**, *10*, 167–175.
- (8) Singh, A. Hovd, M. Dynamic modeling and control of the PRICO LNG process. In *American Institute of Chemical Engineers (AIChE) annual meeting*, San Francisco, CA, Nov 12–17, 2006.
- (9) Zaim, A. Dynamic optimization of an LNG plant, Case study: GL2Z LNG plant in Arzew, Algeria. PhD thesis, RWTH Aachen, 2002.
- (10) Skogestad, S. *Comput. Chem. Eng.* **2004**, *29*, 127–137.
- (11) Jensen, J. B.; Skogestad, S. *Comput. Chem. Eng.* **2007**, *31*, 712–721.
- (12) Wilson, J. A. Jones, W. E. The influence of plant design on refrigeration circuit control and operation. *European Symposium on Computer Aided Process Engineering (ESCAPE) 4*, Dublin, Mar 28–30, 1994; pp 215–221.
- (13) Salim, M. A.; Sadasivam, M.; Balakrishnan, A. R. *Int. J. Energy Res.* **1991**, *15*, 123–135.
- (14) Hallager, L.; Jensen, N.; Jørgensen, S. B. Control system configuration for a heat pump operating as energy source for a distillation column. *Presented at Nordic CACE symposium*, Lynby, Denmark, Jan 26–28, 1990.
- (15) Li, H.; Gani, R.; Jørgensen, S. B. Integration of design and control for energy integrated distillation. In *European Symposium on Computer Aided Process Engineering (ESCAPE) 13*; Lappeenranta, Finland, Jun 1–4, 2003.
- (16) Nielsen, C. S.; Andersen, H. W.; Brabrand, H.; Toftegård, B.; Jørgensen, S. B. Dynamics and identification of distillation pilot plant with heat pump. *Presented at CHISA'87*, Prague, 1987; pp 1–10.
- (17) Nielsen, C. S.; Andersen, H. W.; Brabrand, H.; Jørgensen, S. B. Adaptive Dual Composition Control of a Binary Distillation Column with a Heat Pump. *Preprints IFAC Symposium on Adaptive Control of Chemical Processes (ADCHEM)*. Lyngby, Denmark, Aug 17–19, 1988; pp 220–225.
- (18) Muhrer, C.; Collure, M.; Luyben, W. *Ind. Eng. Chem. Res.* **1990**, *29*, 59–71.
- (19) Govatsmark, M. S. Integrated Optimization and Control. PhD thesis, Norwegian University of Science and Technology (NTNU), Trondheim, Norway, 2003.
- (20) Neeraas, B. O. Brendeng, E. Method and device for small scale liquefaction of a product gas. U. S. Patent number 6,751,984, 2001.
- (21) Newton, C. L.; Kinard, G. E.; Liu, Y. N. C3-MR processes for baseload liquefied natural gas. *Liquefied Natural Gas VIII, Sessions I&II*, Los Angeles, Jun 15–19, 1986; p 1.
- (22) Bach, W. A. *Reports on science and technology Linde*; **2002**; Vol. 63.
- (23) Forg, W.; Bach, W.; Stockmann, R.; Heiersted, R. S.; Paurola, P.; Fredheim, A. O. *Reports on science and technology Linde*; **1999**; Vol. 61.

Received for review April 9, 2008

Revised manuscript received May 13, 2009

Accepted May 20, 2009

IE800565Z