

**APPLICATION OF PLANTWIDE CONTROL TO LARGE
SCALE SYSTEMS. PART I - SELF-OPTIMIZING
CONTROL OF THE HDA PROCESS****Antonio Araújo* Marius Govatsmark*
Sigurd Skogestad*,¹**** Department of Chemical Engineering
Norwegian University of Science and Technology
N-7491 Trondheim, Norway*

Abstract: This paper describes the application of self-optimizing control to a large scale process, the HDA plant. The idea is to select controlled variables which when kept constant lead to minimum economic loss. In order to avoid the combinatorial problem common to the selection of outputs/measurements for such large plants, applications of singular value decomposition (SVD) based methods are used which, although not guaranteeing optimality, give a consistent and practical way for selection. A controllability analysis is carried out to compare the dynamic performance of the selected sets of controlled variables and the conclusion is that the expected performances of the proposed control structures are essentially the same. *Copyright*©2006 IFAC

Keywords:

HDA process, self-optimizing control, selection of controlled variable, sequential design, SVD, RGA, controllability analysis.

1. INTRODUCTION

This paper deals with the selection of controlled variables for the HDA (hydrodealkylation of toluene) process. One of the main objective is to discuss different approaches to tackle the combinatorial control structure problem that can be found in such large-scale problems.

The HDA process, due to McKetta (1977), was first presented in a contest the American Institute of Chemical Engineers arranged for the industry to find enhanced solutions to typical design problems. It has been exhaustively studied by several authors, e.g Stephanopoulos (1984), Brognaux (1992), Cao and Rossiter (1997), Wolff (1994), Herrmann *et al.* (2003), Ng and Stephanopoulos (1996), Ponton and Laing (1993), Brekke (1999), Luyben *et al.* (1998), Luyben

(2002), and Konda *et al.* (2005) (see Table 1) with different objectives, such as steady state design, controllability and operability of the dynamic model and control structure selection and controller design.

2. SELF-OPTIMIZING CONTROL

Definition: *Self-optimizing control is when one can achieve an acceptable loss with constant setpoint values for the controlled variables without the need to re-optimize when disturbances occur (real time optimization).*

To quantify this more precisely, we define the (economic) loss L as the difference between the actual value of the cost function and the truly optimal value, i.e.

$$L(u, d) = J(u, d) - J_{opt}(d) \quad (1)$$

¹ Corresponding author: sigurd.skogestad@chemeng.ntnu.no

Table 1. Selection of controlled variables.

	7	6	5	7	12	9	8	14
Stephanopoulos (1984)								
Brognaux (1992), Cao <i>et al.</i> , Wolff (1994), and Herrmann <i>et al.</i> (2003)								
Ng and Stephanopoulos (1996)								
Ponton and Laing (1993)								
Brekke (1999)								
Luyben <i>et al.</i> (1998) and Luyben (2002)								
Konda <i>et al.</i> (2005)								
This paper								
Number of steady-state economic controlled variables	7	6	5	7	12	9	8	14
Fresh toluene feed rate	x			x				x x
Recycle gas flow rate	x							
Recycle gas hydrogen mole fraction	x				x			x
Recycle gas methane mole fraction			x	x			x	x x
Compressor power					x			x
Compressor outlet pressure						x		
Total toluene flow rate to the reaction section						x		
FEHE by-pass flow rate					x			x
Reactor inlet temperature	x	x			x	x		
Separator temperature				x	x	x		x x
Separator pressure				x	x	x		x
Hydrogen to aromatics ratio at the reactor inlet				x				x x
Hydrogen mole fraction in the reactor outlet					x			
Overall toluene conversion in the reactor								x
Quencher flow rate	x							
Quencher outlet temperature						x	x	x
Purge flow rate	x							
Hydrogen mole fraction in the distillate of the stabilizer				x				
Benzene mole fraction in the distillate of the stabilizer					x			
Boil-up flow rate in the stabilizer						x		
Ratio benzene in feed to benzene in the distillate of the stabilizer								x
Product purity in the distillate of the benzene column	x	x	x		x	x	x	x
Production rate (benzene column distillate flow rate)					x			
Temperature in an intermediate stage of the benzene column						x		
Ratio toluene in feed to toluene in the bottom of the benzene column								x
Toluene mole fraction in the bottom of the benzene column								x
Ratio benzene in feed to benzene in the bottom of the benzene column								x
Ratio toluene in feed to toluene in the distillate of the toluene column							x	x
Toluene column reflux drum level							x	
Temperature in an intermediate stage of the toluene column							x	
Distillate flow rate from the toluene column								x
Toluene mole fraction in the bottom of the toluene column							x	
Toluene mole fraction in the distillate of the toluene column							x	

NB! In addition, separator level, pressure and reflux drum and bottom sump levels of all columns are controlled.

Truly optimal operation corresponds to $L = 0$, but in general $L > 0$. A small value of the loss function L is desired as it implies that the plant is operating close to its optimum. The main issue here is not to find the optimal set points, but rather to find the right variables to keep constant. The precise value of an acceptable loss must be selected on the basis of engineering and economic considerations.

Skogestad (2000) recommends that a controlled variable c suitable for constant set point control (self-optimizing control) should have the following requirements:

- R1.** The optimal value of c should be insensitive to disturbances, i.e., $c_{opt}(d)$ depends only weakly on d .
- R2.** The value of c should be **sensitive** to changes in the manipulated variable u , i.e., the gain $y = Gu$ should be large (equivalently, because $\partial J^2 / \partial^2 c = G^{-T} \partial J^2 / \partial^2 u G^{-1}$, the optimum should be flat with respect to the variable c , i.e., $\partial J^2 / \partial^2 c$ should be small).
- R3.** For cases with two or more controlled variables, the selected variables in c should not be closely correlated.
- R4.** The variable c should be easy to measure and control.

In the present paper, the loss is to be evaluated based on the maximization of the minimum singular value (Skogestad, 2000), which is a combination of the requirements above. This rule states that: *assuming each candidate controlled variable c has been scaled such that the expected variation in $c - c_{opt}$ is of magnitude 1 (including the effect of both disturbances and control error), then select the variables c that minimize the norm of G^{-1} (where G is the scaled steady state*

gain matrix formed by considering the unconstrained degree of freedom only), which in terms of the two-norm is the same as maximizing the minimum singular value of G , $\sigma(G)$. This condition is computationally attractive, but because it only provides local information (based on one equilibrium point), it can be very misleading in some cases, e.g. where the minimum occurs very close to infeasibility.

3. HDA PROCESS

The HDA process (see Figure 1) is used to manufacture benzene by thermal dealkylation of toluene. This is a high-temperature, noncatalytic process in which toluene and hydrogen react to form benzene and methane, with minor amounts of by-product. Excess hydrogen must be used to suppress side reactions and coke formation. The reaction products must be separated, by-products rejected, unreacted toluene recovered and recycled, and the benzene product clay treated and distilled to the proper level of purity.

The model used in this paper and implemented in *MATLABTM* is a slight modified version of the model developed by Brognaux (1992) and later used by Wolff (1994). The difference lies in the introduction of a quencher to cool down the reactor effluent and in the adjustment of the equations used to describe the reactions, as pointed by Cao *et al.* (1998). A simplified model for the separation section is used for optimization purposes since it is assumed that the dynamics of the distillation train is much slower than the remaining of the plant (Brognaux, 1992). It is also assumed the distillation columns have large number of stages leading to high-purity products and product purity has little effect on the cost. In addition, three loops are closed for stability and flexibility reasons.

Details of the process model used in this paper are available on-line at Sigurd Skogestad's home page under "Publication list".

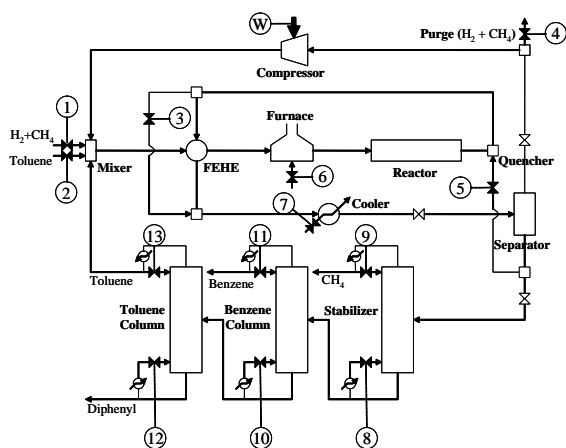

Fig. 1. HDA process flowsheet.

4. RESULTS

4.1 Step 1. Degree of freedom analysis

Table 2 summarizes the degree of freedom analysis for the HDA process considered in this paper. There it is shown the number of steady state operational degrees of freedom (N_{ss}) for the process units.

In addition, there are seven liquid levels (reflux drums and bottom sumps of the distillation columns and separator level) with no steady state effect (they must be stabilized) and the pressures in the distillation columns, all of them consume ten **dynamic** degrees of freedom. One steady state degree of freedom must be selected to keep the quencher outlet temperature at its equality constraint and we are left with thirteen degrees of freedom that can be used for steady state optimization.

Table 2. Steady state degree of freedom analysis

Process units	Manipulations	DOF
External feed streams: feed rate	Valves 1 and 2	2
Splitters: n-1 (n is the number of exit streams)	Valves 3 to 5	3
Compressor: duty	Source W	1
Adiabatic flash ⁽¹⁾	None	0
Gas phase reactor ⁽¹⁾	None	0
Heat exchangers: duties	Valves 6 and 7	2
Distillation columns: LV (or DB) configuration	Valves 8 to 13	6
Equality constraint		
Quencher outlet temperature		-1
Degrees of freedom at steady state		13

⁽¹⁾ No extra valve is assumed: pressure is "given" by the surroundings.

138 candidate controlled variables were identified for this process which gives $\binom{138}{13} = \frac{138!}{13!125!} = 5.9 \cdot 10^{17}$ (!) possible sets of controlled variables. Clearly, this number is intractable for any further computation/consideration. To reduce it, one has first to determine the active constraints which are to be controlled.

4.2 Step 2. Definition of optimal operation

The following profit function ($M\$/year$) based on Douglas (1988)'s economic potential (EP) is to be maximized:

$$-J = (p_{ben}D_{ben} + \sum_{i=1}^{nc} cF_{f,i}) - (p_{tol}F_{tol} + p_{gas}F_{gas} + p_{fuel}Q_{fuel} + p_{cw}Q_{cw} + p_{pow}W_{pow} + p_{stm}Q_{stm}) \quad (2)$$

subject to

1. Production rate:

$$D_{benzene} \geq 265 \text{ lbmol/h} \quad (3)$$

2. Hydrogen to aromatic ratio in reactor inlet:

$$\frac{F_{H_2}}{(F_{benzene} + F_{toluene} + F_{diphenyl})} \geq 5 \quad (4)$$

3. Bound on toluene feed rate:

$$F_{toluene} \leq 300 \text{ lbmol/h} \quad (5)$$

4. Reactor pressure:

$$P_{reactor} \leq 500 \text{ psia} \quad (6)$$

5. Reactor outlet temperature:

$$T_{reactor} \leq 1300^\circ F \quad (7)$$

6. Quencher outlet temperature:

$$T_{quencher} = 1150^\circ F \quad (8)$$

7. Product purity in the benzene column distillate:

$$x_{D_{benzene}} \geq 0.9997 \quad (9)$$

8. Separator inlet temperature:

$$95^\circ F \leq T_{separator} \leq 105^\circ F \quad (10)$$

9. Mole fraction non-negative constraints:

All mole fractions corresponding to the products in the distillation columns are constrained to be non-negative, $x_{purity} \geq 0$.

In addition, all manipulated variables are bounded.

Note that it is assumed that all emissions (purge, stabilizer distillate, and toluene column bottom) are sold as fuel.

4.3 Step 3. Identification of important disturbances

The disturbances considered in this paper are listed in Table 3.

Table 3. Disturbances

Disturbance	Unit	Nominal	Lower	Upper
Bound on toluene feed flow rate	lbmol/h	300	285	315
Fresh toluene feed temperature	$^\circ F$	100	80	120
Gas feed composition	mol% of H_2	95	90	100
Benzene price	$\$/lbmol$	9.04	8.34	9.74
Gas feed temperature	$^\circ F$	100	80	112
Inlet cooling water temperature to cooler	$^\circ F$	59	50	70
Downstream pressure after the purge	psia	350	300	400
Energetic value of fuel to the furnace	MBTU/lbmol	0.1247	0.12	0.13
Relative volatility of hydrogen in stabilizer		36	32.4	39.6
Relative volatility of benzene in benzene column		2.7	2.43	2.97
Relative volatility of toluene in toluene column		10	9	11
Toluene recycle temperature	$^\circ F$	212	202	230

4.4 Step 4. Optimization

Eight constraints are active at the optimal point, namely:

1. Product purity (lower bound)

2. Benzene mole fraction non-negative constraint in the distillate of stabilizer (lower bound)
3. Benzene mole fraction non-negative constraint in the bottom of benzene column (lower bound)
4. Toluene mole fraction non-negative constraint in the bottom of benzene column (upper bound)
5. Toluene mole fraction non-negative constraint in the distillate of toluene column (upper bound)
6. Fresh toluene feed rate (upper bound)
7. Separator inlet temperature (lower bound)
8. Hydrogen to aromatic ratio in reactor inlet (lower bound)

All of them must be controlled to achieve optimal operation, at least nominally (active constraint control).

Consequently, the number of unconstrained degrees of freedom is found to be **five**. This reduces the number of possible sets of controlled variables to $\binom{129}{5} = \frac{129!}{5!124!} = 275, 234, 400$. However, this is still too large a number to be further considered in the analysis.

4.5 Step 5. Identification of candidate controlled variables - local analysis

As seen before, the number of possible sets of controlled variables is very large and impossible to be handled. Skogestad and Postlethwaite (2005) note that the number of combinations has a combinatorial growth, so even a simple input-output controllability analysis becomes unmanageable if there are too many alternatives. One way of avoiding this combinatorial problem is to base the selection directly on the “big” linear model G_{all} of the plant (in the present case, G_{all} is the 129×5 matrix, where the active constraints and the sole equality constraint are not considered). One may consider the singular value decomposition and relative gain array of G_{all} as discussed later in this section. This rather crude analysis may be used, together with physical insight, rules of thumb and simple controllability measures, to perform a pre-screening in order to reduce the possibilities to a manageable number. These candidate combinations can then be analyzed more carefully.

The matrix G_{all} is scaled such that each candidate controlled variable has the expected variation from its optimal ($c - c_{opt}$) of magnitude 1 for all disturbances and the inputs all have the same effect on the cost function J (Skogestad and Postlethwaite, 2005). According to the maximum singular value rule, one should select controlled variables with large gains from the inputs to the outputs (maximization of the minimum singular value).

It is possible to find the optimal combination of outputs as outlined in Section 4.5.4 below. However, this is rather time consuming, so it will be first considered three related methods that do not require much use of computation. The three methods are all based on an SVD of $G_{all} = U_r \Sigma_r V_r^T$ (economy size SVD),

where r represents the rank of G_{all} , and make use of the output singular vector U_r (in general, one wants to select outputs with large elements in U_r):

4.5.1. Sequential SVD selection: The idea is to select sequentially the output that corresponds to the largest element of the first column of U_r (corresponding to the largest singular value), remove this variable by closing the loop between this output and one input (the choice of the input does not matter for this analysis), and obtain the new matrix G_{all} with one input (and output) less until only one candidate controlled variable remains.

4.5.2. “One-shot” RGA selection: Another simple yet effective screening tool for selecting inputs and outputs, which avoids the combinatorial problem, is the relative gain array (RGA) of the “big” scaled transfer matrix G_{all} with all candidate inputs and outputs included, $\Lambda = G_{all} \otimes G_{all}^\dagger$ (where \dagger is the pseudo-inverse operator). Essentially, the method is an SVD-type since the sum of the elements of row i in the RGA matrix is equal to the 2-norm of row i in U_r , i.e. $\sum_{j=1}^n \lambda_{i,j} = \|e_i^T U_r\|_2^2$ (Cao and Rossiter, 1997). So, it is preferred to select outputs corresponding to rows in the RGA where the sum of the elements is larger.

4.5.3. Sequential RGA selection: At each step in this method, the output with the largest RGA row sum is selected. This is the same as the previous method, except that it is done sequentially as for the sequential SVD method.

The results are shown in Table 4 and 5. The overall matrix with all outputs (the 129 outputs \times 5 inputs matrix) has $\sigma(G_{all}) = 37$. The sequential SVD and sequential RGA plants both have the same set of unconstrained controlled variables.

4.5.4. Optimal selection: A branch-and-bound algorithm based on the maximization of the minimum singular value was used to calculate the optimal set(s) of controlled variables. Five sets were identified and their minimum singular values differ only slightly from the sequential SVD and RGA: all five sets have $\sigma_{opt}(G_{5 \times 5}) = 14.89$. On the other hand, the optimal set s of variables differ quite a lot from the local methods (SVD and RGA). The optimal sets are also shown in Table 5.

Now, the selected sets of controlled variables are to be used in the evaluation of the loss.

4.6 Step 6. Evaluation of loss

The evaluation of the loss for alternative combinations of controlled variables is done by computing the loss imposed by keeping constant set-points when there are

Table 4. Selected controlled variables.

Selected controlled variables	
1	Hydrogen mole fraction in mixer outlet
2	Diphenyl mole fraction in mixer outlet
3	FEHE hot side outlet temperature
4	Flow rate through bypass in FEHE
5	Recycle gas hydrogen mole fraction
6	Compressor power
7	Separator pressure
8	Hydrogen mole fraction in benzene column bottom
9	Methane mole fraction in benzene column bottom
10	Toluene mole fraction in benzene column bottom
11	Diphenyl mole fraction in benzene column bottom
12	Boil-up flow rate in toluene column
13	Reflux flow rate in toluene column
14	Toluene mole fraction in toluene column distillate

Table 5. Results for the selection of outputs.

Method	Variables	Minimum singular value of the $G_{5 \times 5}$ matrix
Sequential SVD	4, 5, 6, 10, 14	13.91
"One-shot" RGA	3, 4, 6, 10, 11	$5.74 \cdot 10^{-8}$
Sequential RGA	4, 5, 6, 10, 14	13.91
Optimal selection - Set 1	1, 2, 3, 8, 12	14.89
Optimal selection - Set 2	1, 2, 7, 9, 12	14.89
Optimal selection - Set 3	1, 2, 7, 8, 12	14.89
Optimal selection - Set 4	1, 2, 9, 12, 13	14.89
Optimal selection - Set 5	1, 2, 8, 12, 13	14.89

disturbances or implementation errors. The average losses show basically no difference between the sets although the loss for the "one-shot" RGA is the largest one. The other authors' selection shown in Table 1 will give larger losses as their selections were not based on optimal assumptions.

4.7 Step 7. Final evaluation and selection

The analysis up to now has been based purely on steady state economics and nothing has been said about implementation of the proposed controlled variables. Obviously, this is also an important issue, as one choice of controlled variables might result in a system that is easy to control whereas another might result in serious control problems, for example, caused by unstable (RHP) zeros (the multivariable extension of inverse response behavior). The truly optimal approach would be to solve the entire problem as one big optimization problem, taking into account both economics and control. However, this is intractable for most real problems, and the approach taken in this paper is therefore preferred. Here, candidate sets of controlled variables with acceptable steady-state economics are firstly identified. The (input-output) controllability of the best alternative is then checked. If it is acceptable, then a viable solution has been found.

If it is not, the remaining candidate sets are checked. If none of these turns out to be controllable, then the requirements on the steady state economics must be relaxed and more candidate sets must be considered.

4.7.1. *Controllability analysis of the eight 14×14 sets of controlled variables:* A controllability analysis based on Skogestad and Postlethwaite (2005) on page 253 was carried out on each set of candidate outputs and essentially no performance difference was found.

5. DISCUSSION

As expected, benzene purity at the outlet of the process is kept at its bound for economic reasons. Moreover, fresh feed toluene is maintained at its maximum flow rate to maximize the profit ($D_{benzene} > 265$). The separator inlet temperature is kept at its lower bound in order to maximize the recycle of hydrogen and to avoid the accumulation of methane in the process. Luyben's rule of keeping all recycle loops under flow control seems to lose its meaning in this process since it is economically optimum to leave the recycle flows fluctuate.

The selection of disturbances used in this paper was based on the work by Brognaux (1992) and some heuristics. Alstad (2005) approaches this subject in a more systematic way aiming to optimize the solution of the problem. Not all disturbances are of importance ($\|g_d(j\omega)\|_2 \leq 1, \forall \omega$) in a steady state point of view. The change in the price of benzene is the most important disturbance considered, but in practice nothing can be done to mitigate it.

The number of measurements is really very large, 138, but in practice not all of them can be regarded for a possible use due to operational limitations or impediments, f. e. composition measurements are rather difficult and very costly. The engineer's judgment must come at this stage in order to specify the number of degrees of freedom that can really be considered for the analysis. This pre-screening can substantially reduce the dimension of the problem and thus the number of controlled variable combinations. But there might be situations where the remaining number of possibilities is still very large, in which case one can try to perform a local analysis (based on an equilibrium point) that can lead to a good selection which can be found optimal by using optimization technique like branch-and-bound algorithms or some sub-optimal approach like the SVD-based calculations used in this paper. They are not guaranteed to give the best solution but due to their practicality and ease of use, they become very attractive in practice.

In summary, all the selected sets generate stable (no RHP-poles) plants and inverse responses are not expected (no RHP-zeros). Moreover, input saturation is expected for set point changes but not for disturbance

rejection and it can be concluded that all alternatives, including the optimal selection of controlled variables, are equally easy to control.

From an implementation standpoint, “the best” set of variables to be controlled would be the one found by either the sequential SVD or RGA methods based on local analysis (corresponding to $\underline{\sigma}(G_{5 \times 5}) = 13.91$). One possible control structure is shown in Figure 2. It is assumed that all lower layer loops are closed (regulatory control layer), e.g. level of the reflux drums and bottoms of all distillation columns as well as of the separator.

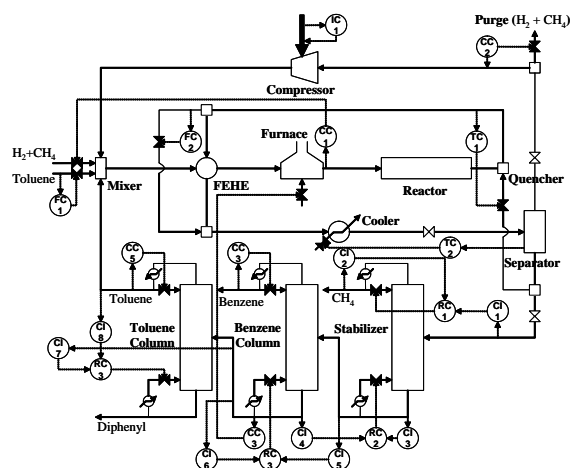

Fig. 2. Proposed control structure with controlled variables determined by the sequential SVD method.

6. CONCLUSIONS

This paper discussed the selection of controlled variables for the HDA process using the self-optimizing control procedure. The large number of variable combinations made it a very challenging problem in the sense that new approaches had to be used to decide for suitable outputs. Eight candidate sets were found by local analysis based on the SVD of the “big” scaled linear plant G_{all} . These easy-to-use tools for the selection of outputs produced a sub-optimal result which is not far away from the optimum found by applying integer optimization methods, namely branch-and-bound techniques. A controllability analysis showed that the dynamic performances of the proposed sets of controlled variables were essentially the same.

REFERENCES

- Alstad, V. (2005). Studies on selection of controlled variables. PhD thesis. Norwegian University of Science and Technology, Trondheim, Norway.
- Brekke, K. (1999). Optimization and control of the HDA process. Master thesis. Norwegian University of Science and Technology, Trondheim, Norway.
- Brognaux, C. (1992). A case study in operability analysis: The HDA plant. Master thesis. University of London, London, England.
- Cao, Y. and D. Rossiter (1997). An input pre-screening technique for control structure selection. *Computers and Chemical Engineering* **21**(6), 563–569.
- Cao, Y., D. Rossiter, D.W. Edwards, J. Knechtel and D. Owens (1998). Modelling issues for control structure selection in a chemical process. *Computers and Chemical Engineering* **22**(Suppl.), S411–S418.
- Douglas, J. M. (1988). *Conceptual Design of Chemical Processes*. McGraw-Hill. USA.
- Herrmann, G., S. K. Spurgeon and C. Edwards (2003). A model-based sliding mode control methodology applied to the hda-plant. *Journal of Process Control* **13**, 129–138.
- Konda, N. V. S. N. M., G. P. Rangaiah and P. R. Krishnaswamy (2005). Simulation based heuristics methodology for plant-wide control of industrial processes. In: *Proceedings of 16th IFAC World Congress*. Praha, Czech Republic.
- Luyben, W. L. (2002). *Plantwide dynamic simulators in chemical processing and control*. Marcel Dekker, Inc., New York, USA.
- Luyben, W. L., B. D. Tyr us and M. L. Luyben (1998). *Plantwide process control*. McGraw-Hill. USA.
- McKetta, J. J. (1977). *Benzene design problem*. Encyclopedia of Chemical Processing and Design. Dekker, New York, USA.
- Ng, C. and G. Stephanopoulos (1996). Synthesis of control systems for chemical plants. *Computers and Chemical Engineering* **20**, S999–S1004.
- Ponton, J.W. and D.M. Laing (1993). A hierarchical approach to the design of process control systems. *Trans IChemE* **71**(Part A), 181–188.
- Skogestad, S. (2000). Plantwide control: The search for the self-optimizing control structure. *Journal of Process Control* **10**, 487–507.
- Skogestad, S. and I. Postlethwaite (2005). *Multivariable Feedback Control: Analysis and Design*. John Wiley & Sons. Chichester, UK.
- Stephanopoulos, G. (1984). *Chemical process control*. Prentice-Hall International Editions. New Jersey, USA.
- Wolff, E. A. (1994). Studies on control of integrated plants. PhD thesis. Norwegian University of Science and Technology, Trondheim, Norway.