

Control and optimal operation of simple heat pump cycles

Jørgen Bauck Jensen and Sigurd Skogestad *

*Department of Chemical Engineering
Norwegian University of Science and Technology
N-7491 Trondheim, Norway*

Abstract

Cycles for heating and cooling have traditionally been studied in detail when it comes to thermodynamics and design. However, there are few publications on their optimal operation which is the theme of this paper. One important issue is which variable to control, for example, degree of super-heating, pressure, liquid level or valve opening. Also, unlike open systems, the initial charge to the cycle may have a steady state effect, and it is discussed how different designs are affected by this factor. Numerical results are provided for an ammonia cycle.

Key words: Operation, self-optimizing control, vapour compression cycle

1 Introduction

Cyclic processes for heating and cooling are widely used in many applications and their power ranges from less than 1 kW to above 100 MW. Most of these applications use the vapor compression cycle to “pump” energy from a low to a high temperature level.

The first application, in 1834, was cooling to produce ice for storage of food, which led to the refrigerator found in every home Nagengast (1976). Another well-known system is the air-conditioner (A/C). In colder regions a cycle operating in the opposite direction, the “heat pump”, has recently become popular. These two applications have also merged together to give a system able to operate in both heating and cooling mode.

* skoge@chemeng.ntnu.no

A schematic drawing of a simple cycle is shown in Figure 1 together with a typical pressure-enthalpy diagram for a sub-critical cycle. The way the cycle works:

The low pressure vapour (4) is compressed by supplying work W_s to give a high pressure vapour with high temperature (1). This stream is cooled to the saturation temperature in the first part of the condenser, condensed in the middle part and possibly sub-cooled in the last part to give the liquid (2). In the expansion choke, the pressure is lowered to its original value, resulting in a two-phase mixture (3). This mixture is vaporized and heated through the evaporator giving a super-heated vapour (4) closing the cycle.

The coefficients of performance for a heating cycle (heat pump) and a cooling cycle (refrigerator, A/C) are defined as

$$COP_h = \frac{Q_h}{W_s} = \frac{h_1 - h_2}{h_1 - h_4} \quad \text{and} \quad COP_c = \frac{Q_c}{W_s} = \frac{h_4 - h_3}{h_1 - h_4} \quad (1)$$

respectively. Heat pumps typically have a COP of around 3 which indicates that 33% of the gained heat is added as work (eg. electric power).

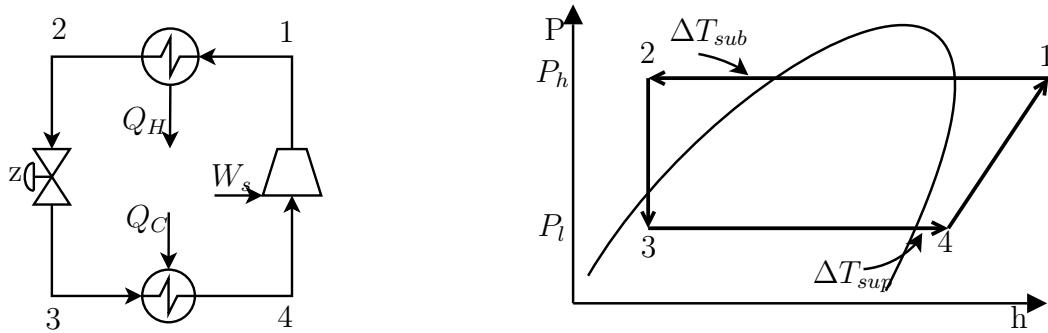

Fig. 1. Schematics of a simple vapor compression cycle with typical pressure-enthalpy diagram indicating both sub-cooling and super-heating

In industrial processes, especially in cryogenic processes such as air separation and liquefaction of natural gas (LNG process), more complex cycles are used in order to improve the thermodynamic efficiencies. These modifications lower the temperature differences in the heat exchangers and include cycles with mixed refrigerants, several pressure levels and cascaded cycles. The Mixed Fluid Cascade process developed by the Statoil Linde Technology Alliance is being built at the LNG plant in northern Norway and incorporates all of the above modifications. The resulting plant has three cycles, all with mixed refrigerant and the first with two pressure levels. Our long term objective is to study the operation of such processes. However, as a start we need to understand the simple cycle in Figure 1.

2 Operation of simple vapour compression cycles

2.1 Design versus operation

Table 1 shows typical specifications for simple cycles in design (find equipment) and in operation (given equipment). Note that the five design specifications results in only four equipment parameters; compressor work W_s , valve opening z and UA for the two heat exchangers. As a consequence, with the four equipment parameters specified, there is not a unique solution in terms of the operation. The “un-controlled” mode is related to the pressure level, which is indirectly set by the charge of the system. This is unique for closed systems since there is no boundary condition for pressure. In practice, the “pressure level” is adjusted directly or indirectly, depending on the design, especially of the evaporator. This is considered in more detail below.

Table 1
Specifications in design and operation

	Given	#
Design	Load (e.g. Q_h), P_l , P_h , ΔT_{sup} and ΔT_{sub}	5
Operation	W_s (load), choke valve opening (z) and UA in two heat exchangers	4

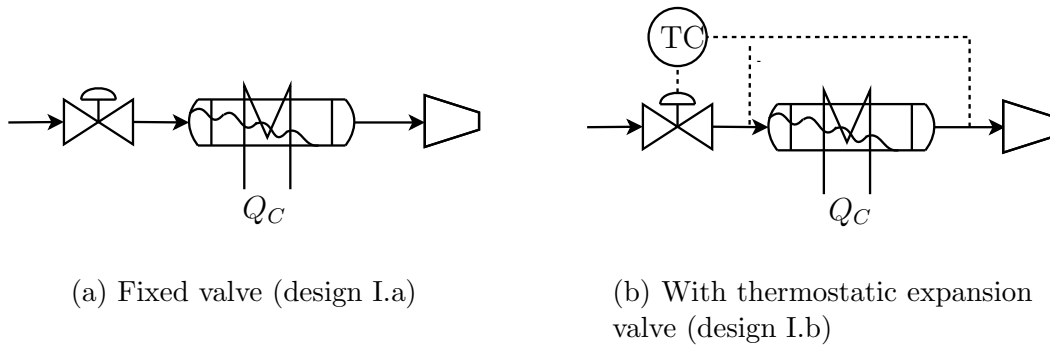

Fig. 2. Dry evaporator

2.2 Operational (control) degrees of freedom

During operation the equipment is given. Nevertheless, we have some operational or control degrees of freedom. These include the compressor power (W_s), the charge (amount of vapour and liquid in the closed system), and the valve openings. The following valves may be adjusted on-line:

- Adjustable choke valve (z); see Figure 1 (not available in some simple cycles)

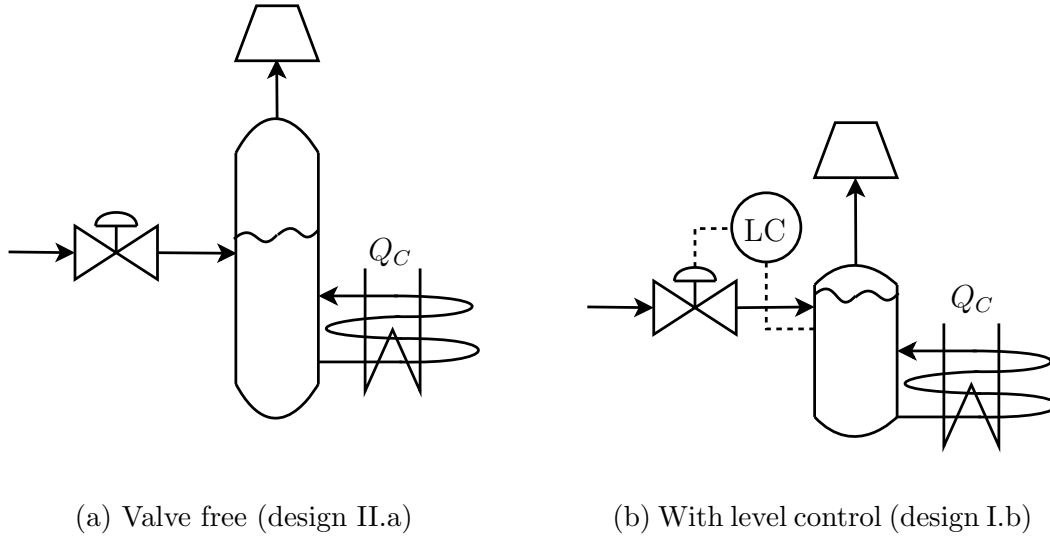

Fig. 3. Flooded evaporator

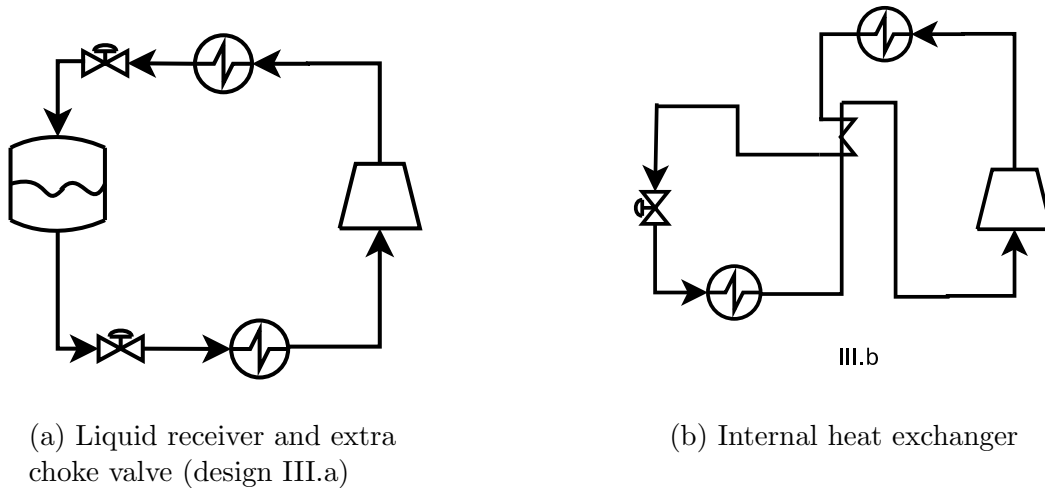

Fig. 4. Liquid receiver (design III.b)

- Adjustable valve between condenser and storage tank (for designs with a separate liquid storage tank before the choke; see design III.a in Figure 4(a))

In addition, we might install bypass valves on the condenser and evaporator to effectively reduce UA , but this is not normally used because use of bypass gives suboptimal operation.

Some remarks:

- The compression power W_s sets the “load” for the cycle, but it is otherwise not used for optimization, so in the following we do not consider it as an operational degree of freedom.

- The charge has a steady-state effect for some designs because the pressure level in the system depends on the charge. A typical example is household refrigeration systems. However, such designs are generally undesirable. First, the charge can usually not be adjusted continuously. Second, the operation is sensitive to the initial charge and later to leaks.
- The overall charge has no steady-state effect for some designs. This is when we have a storage tank where the liquid level has no steady-state effect. This includes designs with a liquid storage tank after the condenser (design III.a Figure 4(a)), as well as flooded evaporators with variable liquid level (design II.b Figure 3(a)). For such designs the charge only effects the level in the storage tank. Note that it may be possible to control (adjust) the liquid level for these designs, and this may then be viewed as a way of continuously adjusting the charge to the rest of the system (condenser and evaporator).
- There are two main evaporator designs; the dry evaporator (2) and the flooded evaporator (3). In a dry evaporator, we generally get some super-heating, whereas there is no (or little) super-heating in a flooded evaporator. The latter design is better thermodynamically, because super-heating is undesirable from an efficiency (COP) point of view. In a dry evaporator one would like to control the super-heating, but this is not needed in a flooded evaporator. In addition, as just mentioned, a flooded evaporator with variable liquid level is insensitive to the charge.
- It is also possible to have flooded condensers. and thereby no sub-cooling, but this is not desirable from a thermodynamic point of view.

2.3 Use of the control degrees of freedom

In summary, we are during operation left with the valves as degrees of freedom. These valves should generally be used to optimize the operation, In most cases “optimal operation” is defined as maximizing the efficiency factor, COP. We could then envisage an on-line optimization scheme where one continuously optimizes the operation (maximizes COP) by adjusting the valves. However, such schemes are quite complex and sensitive to uncertainty, so in practice one uses simpler schemes where the valves are used to control some other variable. Such variables could be:

- Valve position setpoint z_s (that is, the valve is left in a constant position)
- High pressure (P_h)
- Low pressure (P_l)
- Temperature out of condenser (T_2) or degree of sub-cooling ($\Delta T_{sub} = T_2 - T_{sat}(P_h)$)
- Temperature out of evaporator (T_4) or degree of super-heating ($\Delta T_{sup} = T_4 - T_{sat}(P_l)$)
- Liquid level in storage tank (to adjust charge to rest of system)

The objective is to achieve “self-optimizing” control where a constant setpoint for the selected variable indirectly leads to near-optimal operation Skogestad (2000).

Control (or rather minimization) of the degree of super-heating is useful for dry evaporator with TEV (design II.b Figure 2(b)). However, it consumes a degree of freedom. In order to retain the degree of freedom, we need to add a liquid storage tank after the condenser (design III.a Figure 4(a)). In a flooded evaporator, the super-heating is minimized by design so no control is needed.

With the degree of super-heating fixed (by control or design), there is only one degree of freedom left that needs to be controlled in order to optimize COP. To see this, recall that there are 5 design specifications, so optimizing these give an optimal design. During operation, we assume the load is given (W_s), and that the maximum areas are used in the two heat exchangers (this is optimal). This sets 3 parameters, so with the super-heating controlled, we have one parameter left that effects COP.

In conclusion, we need to set one variable, in addition to ΔT_{sup} , in order to completely specify (and optimize) the operation. This variable could be selected from the above list, but there are also other possibilities. Some common control schemes are discussed in the following.

2.4 Some alternative designs and control schemes

Some designs are here presented and the pro’s and con’s are summarized in Table 2.

2.4.1 Dry evaporator (I)

For this design there is generally some super-heating.

I.a In residential refrigerators it is common to replace the valve by a capillary tube, which is a small diameter tube designed to give a certain pressure drop. On-off control of the compressor is also common.

I.b Larger systems usually have a thermostatic expansion valve (TEV) , Dosat (2002) and Langley (2002), that controls the temperature and avoids excessive super-heating. A typical super-heat value is 10 °C.

2.4.2 Flooded evaporator (II)

A flooded evaporator differs from the dry evaporator in that it only provides vaporization and no super-heating.

II.b In flooded evaporator systems the valve is used to control the level in either evaporator or condenser (Figure 3(b)).

II.a We propose a design where the volume of the flooded evaporator is so large that there is no need to control the level in one of the heat exchangers. This design retains the valve as a degree of freedom (Figure 3(a)).

2.4.3 Other designs (III)

III.a To reduce the sensitivity to the charge in designs I.b and II.b it is possible to include a liquid receiver before the valve as shown in figure 4(a). To retain a degree of freedom a valve may be added before the receiver.

III.b It is possible to add an internal heat exchanger as shown in figure 4(b). This will super-heat the vapor entering the compressor and sub-cool the liquid before expansion. The latter is positive because of reduced expansion losses, whereas the first is undesirable because compressor power increases.

Table 2
Operation of alternative designs

	Pro's	Con's
I.a	Simple design	Sensitive to charge No control of super-heating
I.b	Controlled super-heating	Super-heating Sensitive to charge
II.a	No super-heating by design Not sensitive to charge Valve is free	How to use valve?
II.b	No super-heating by design	Sensitive to charge
III.a	Not sensitive to charge	Complex design How to use valve?

3 Ammonia case study

3.1 System description

The cycle operates between air inside a building ($T_C = T_{room}$) and ambient air ($T_H = T_{amb}$) removing 20 kW of heat (Q_C) from the building. This could be used in a large cold storage building as illustrated in Figure 5.

Thermodynamics: Ideal gas, incompressible liquid and constant heat capacity in each phase. Reference temperature is $T_0 = 267.79K$. $C_p(l) = 77.9 J/(mol K)$, $C_p(v) = 43.8 J/(mol K)$ and $\Delta_{vap}h(T_0) = 21.77 kJ/(mol K)$.

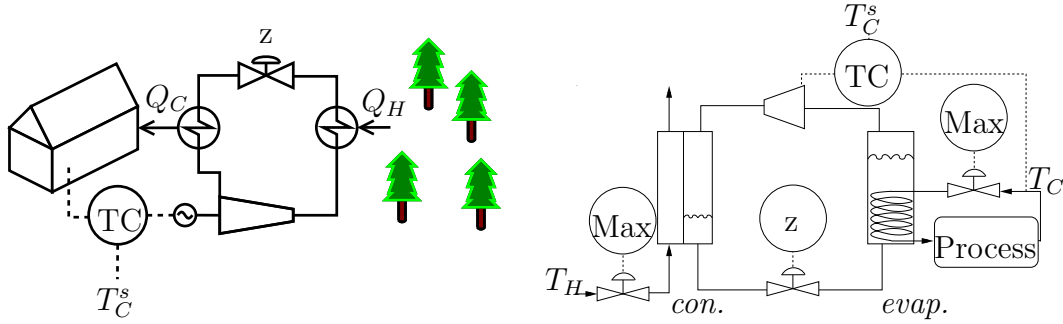

Fig. 5. Cold warehouse with ammonia refrigeration unit

3.2 Difference between design and operation

There are fundamental differences between optimal design and optimal operation. In the first case we need to find the equipment that minimizes the total cost of the plant (investments and operational costs). In the latter case however, the equipment is given so we only need to consider the operational costs.

A typical approach when designing heat exchanger systems is to specify the minimum temperature differences (pinch temperatures) in the heat exchangers (see Equation 2). In operation this is no longer a constraint, but we are given a certain heat transfer area by the design (see Equation 3).

$$\begin{aligned}
 & \min \quad Ws & (2) \\
 & \text{such that} \quad T_C - T_C^s = 0 \\
 & \quad \quad \quad \Delta T - \Delta T_{\min} \geq 0
 \end{aligned}$$

$$\begin{aligned}
& \min W_s & (3) \\
& \text{such that } T_C - T_C^s = 0 \\
& A_{\max} - A \geq 0
\end{aligned}$$

The two optimization problems are different in one constraint, so there might be a different solution even with the same conditions.

We will now solve the two optimization problems in Equation 2 and 3 with the following conditions:

- Ambient temperature $T_H = 25 \text{ }^\circ\text{C}$
- Indoor temperature set point $T_C^s = -12 \text{ }^\circ\text{C}$

Temperature control maintains $T_C = T_C^s$ which indirectly gives $Q_C = Q_{loss} = UA \cdot (T_H - T_C)$. The minimum temperature difference in the heat exchangers are set to $\Delta T_{min} = 5 \text{ }^\circ\text{C}$ in design. In operation the heat exchanger area A_{max} is fixed at the optimal design value.

Figure 6(a) shows pressure enthalpy diagram for the optimal design with no sub-cooling in the condenser. In operation however, there is sub-cooling as seen in Figure 6(b).

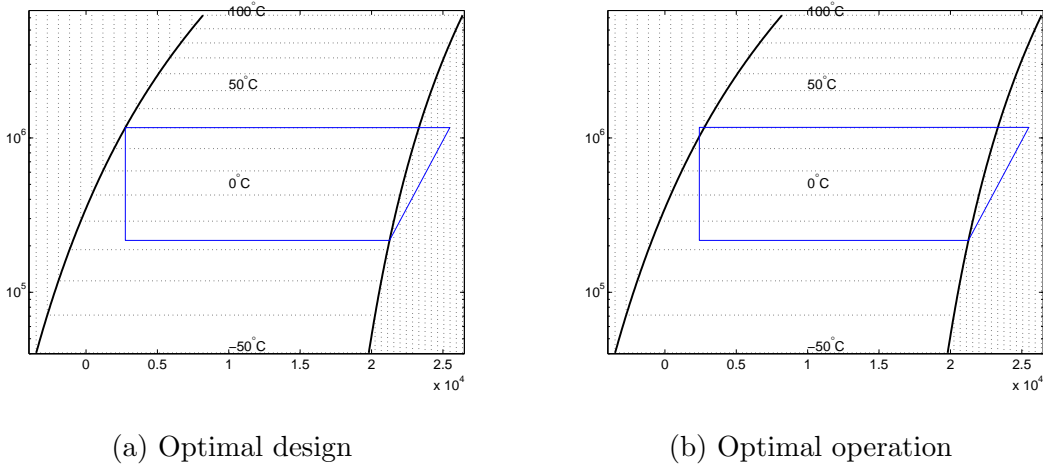

Fig. 6. Difference in optimal design and optimal operation for same conditions

Conclusion: For this ammonia cycle, sub-cooling by $4.5 \text{ }^\circ\text{C}$ reduces the compression work W_s by 1.59% which is contrary to popular belief. The high pressure P_{con} increases by 0.32%, but this is more than compensated by a 1.85% reduction in flowrate. The condenser charge M_{con} is increased by 3.9% in optimal operation.

Similar results are obtained for a CO_2 cycle with more realistic thermodynamics (Span-Wagner equation of state Span and Wagner (1996)).

Table 3

Difference between optimal design and optimal operation

	W_s	Flow	M_{con} ^a	ΔT_{sub}	P_{con}	P_{evap}	A_{con}	A_{vap}
	[W]	[mol/s]	[mol]	[K]	[Pa]	[Pa]	[m ²]	[m ²]
Optimal design	4565	1.081	9330	0	1166545	216712	6.55	4.00
Optimal operation	4492	1.061	9695	4.5	1170251	216712	6.55	4.00

^a Evaporator charge has no effect

3.3 Linear analysis of alternative controlled variables (CV's)

To find promising controlled variables the method in Skogestad (2000) will be utilized. In short:

We are looking for variables which optimal value (y_{opt}) change little when the system is exposed to disturbances. We also need a sufficient gain from the input to the variable ($G = \frac{\Delta y}{\Delta u}$).

Procedure:

- Make a small perturbation in all disturbances (same fraction of expected disturbance) and re-optimize the operation to find the optimal change in each variable for each disturbance ($\Delta y_{opt}(d_1)$, $\Delta y_{opt}(d_2)$, ...). Large $\Delta y_{opt}(d_i)$ indicates control problems for disturbance i.
- Do a perturbation in the independent variables (u) to find the gain to all variables ($G = \frac{\Delta y}{\Delta u}$).
- Scale the gain. *span* $y = \Delta y_{opt}$ without implementation error.

$$G' = \frac{G}{\text{span } y}$$
- Variables with large scaled gains G' are promising controlled variables.

In this case study we only have one independent variable $u = z$ (choke valve opening). The following disturbance perturbations are considered (1 % of expected disturbance):

$$\hat{d}_1: \Delta T_H = +0.1 \text{ } ^\circ\text{C}$$

$$\hat{d}_2: \Delta T_C^s = +0.05 \text{ } ^\circ\text{C}$$

The heat loss is given by Equation 4, and temperature control will indirectly give $Q_C = Q_{loss}$.

$$Q_{loss} = UA \cdot (T_H - T_C) \quad (4)$$

Table 4 shows the linear analysis presented above. Some notes about the table:

- The table represents a sample of all the variables in the model and include the best candidates together with some of the less promising ones.

Table 4
Linear analysis of the ammonia case study

Variable		$\Delta y_{opt}(\hat{d}_1)$	$\Delta y_{opt}(\hat{d}_2)$	G	$G'(\hat{d}_1)$	$G'(\hat{d}_2)$
Con. pressure P_h	[Pa]	3689	3393	-464566	-126	-137
Evap. pressure P_l	[Pa]	-167	418	0	0	0
Valve opening z	[-]	$8.00 \cdot 10^{-4}$	$3.00 \cdot 10^{-5}$	1	1250	33333
Liq. level in evap.	[m^3]	$-1.00 \cdot 10^{-5}$	$1.00 \cdot 10^{-5}$	1.05	105087	105087
Liq. level in con.	[m^3]	$6.7 \cdot 10^{-6}$	$4.3 \cdot 10^{-6}$	-1.06	157583	244624
Temp. out of con.	[K]	0.103	0.101	316	3074	3115
ΔT_{sub}	[K]	0.0165	0.0083	331	20017	39794
ΔT at con. exit	[K]	0.0027	0.0101	316	118216	3115

- This is a linear approach, so for larger disturbances we need to check the promising candidates for nonlinear effects.
- The procedure correctly reflects that pressure control is bad, being infeasible (evaporator pressure) or far from optimal (condenser pressure).
- The loss is proportional to the inverse of squared scaled gain ($Loss = (1/G')^2$). This implies that a constant condenser pressure would result in about hundred times larger loss than a constant valve opening when there is a disturbance in the ambient temperature. For set point change in the room temperature the difference is even larger.
- Liquid level in evaporator is a common way to control flooded evaporator systems Langley (2002), there are however two candidates that are more promising. These are degree of sub-cooling and liquid level in condenser (also a scheme showed in Langley (2002)).

3.4 Nonlinear analysis of promising CV's

The nonlinear model is subjected to full disturbances:

$$d_1: \Delta T_H = +10^\circ C$$

$$d_2: \Delta T_H = -10^\circ C$$

$$d_3: \Delta T_C^s = +5^\circ C$$

$$d_4: \Delta T_C^s = -5^\circ C$$

Table 5 shows the loss compared with re-optimized operation for different control policies.

Conclusion:

- The best strategy, by far, is a constant condenser liquid level policy which

Table 5
Loss for different control policies

Constant	ΔW_s [%]			
	d_1	d_2	d_3	d_4
Valve opening z	10.8	12.0	9.8	12.7
Con. pressure P_h	Inf	43	2.5	Inf
Temp. out of con.	Inf	Inf	0.0079	0.0086
Liq. level evap.	0.013	0.012	$1.34 \cdot 10^{-5}$	0.00
Liq. level con.	0.0024	0.003	$4.2 \cdot 10^{-4}$	$2.8 \cdot 10^{-4}$
Sub-cooling ΔT_{sub}	0.39	4.0	0.69	0.131

Inf = Infeasible

gives a loss that is less than 0.0031 % for all disturbances.

- Evaporator liquid level gives a maximum loss of 1.55 %.
- Both of these strategies are used in heat pump systems Langley (2002).
- Another good policy is to maintain constant degree of sub-cooling in the condenser. The maximum loss is about 4 %. This control policy has as far as we know not been reported in the literature.
- According to Larsen et al. (2003) a constant condenser pressure is most frequently used in refrigeration systems, but according to Table 5 this will give large losses and might give infeasible operation.

4 Conclusion

- A detailed degree of freedom analysis shows that there is at most one degree of freedom in simple vapour compression cycles. This degree of freedom is related to changing the active charge in the system.
- We have shown that there is a difference between optimal design and optimal operation. For the same conditions we are able to save almost 1.6 % electric power in operation compared with optimal design.
- A simple linear approach is used to find promising controlled variables for the remaining degree of freedom. Several good candidates are identified (liquid levels in heat exchangers, degree of sub-cooling) whereas others are immediately rejected (pressures, condenser outlet temperature).
- All promising controlled variables are tested on the nonlinear model. Among the best control strategies are two that are frequently used (liquid level in evaporator and liquid level in condenser) and one that we have not seen in literature (degree of sub-cooling).

References

- Dossat, R. J., 2002. Principles of refrigeration. Prentice Hall.
- Langley, B. C., 2002. Heat pump technology. Prentice Hall.
- Larsen, L., Thybo, C., Stoustrup, J., Rasmussen, H., September 2003. Control methods utilizing energy optimizing schemes in refrigeration systems. In: ECC2003, Cambridge, U.K.
- Nagengast, B., 1976. The revolution in small vapor compression refrigeration. ASHRAE 18 (7), 36–40.
- Skogestad, S., 2000. Plantwide control: the search for the self-optimizing control structure. *Journal of Process Control* 10 (5), 487–507.
- Span, R., Wagner, W., 1996. A new equation of state for carbon dioxide covering the fluid region from the triple-point temperature to 1100 k at pressures up to 800 mpa. *J. Phys. Chem. Ref. Data* 25 (6), 1509–1596.

Acknowledgments

This work has been done as part of the The Gas Technology Center, NTNU-SINTEF. Funding from the Norwegian Research Council is gratefully acknowledged.