

## COMPLEXITY MEASURE FOR BLOCK DIAGRAMS

E. S. Hori<sup>1</sup>, S. Skogestad<sup>2\*</sup>, W. H. Kwong<sup>3</sup>

1- Departamento de Engenharia Química – Universidade Federal de São Carlos  
Campus Universitário, Km 235 –CEP: 13565-905 – São Carlos – SP – Brasil  
Telefone: (0-xx-16)260-8264 – Fax: (0-xx-16)260-8266 – Email: pshiguelo@iris.ufscar.br

2- Chemical Engineering Department – Norwegian University of Science and Technology  
N-7491 – Trondheim – Norway

Telefone: +47-7359-4154 – Fax: +47-7359-4080 – Email: [skoge@chemeng.ntnu.no](mailto:skoge@chemeng.ntnu.no).

\*(to whom all correspondence should be addressed)

3- Departamento de Engenharia Química – Universidade Federal de São Carlos

Campus Universitário, Km 235 –CEP: 13565-905 – São Carlos – SP – Brasil

Telefone: (0-xx-16)260-8264 – Fax: (0-xx-16)260-8266 – Email: wu@power.ufscar.br

**ABSTRACT** – The concept of complexity has been widely studied in the last years in several different areas. Although many writers on the subject understand qualitatively similar things by the term "complexity", a transition from this qualitative understanding to a quantitative approach would be highly desirable and necessary. The lack of understanding in this area has hindered planners in deciding how much integration is beneficial and beyond which point integration is actually detrimental to system performance, since correct decisions are difficult to make due to high system complexity. The objective of this paper is to present a method to quantify the static complexity of a block diagram in a way that can be useful for process control structure selection. The method is applied in several examples. The importance of this evaluation is to help to produce good control structures with the smallest possible complexity due to the fact that the costs of implementation increase in large complex systems. Once determined a way to quantify it, it is possible to minimize the complexity of this system keeping the same control performance.

**KEYWORDS:** complexity; block diagrams; measure.

### 1. INTRODUCTION

The concept of complexity has been widely studied in the last years in several different fields, e.g., system analysis (Ben-Hur et al., 2002), manufacturing processes (Deshmukh et al., 1998; Calinescu et al., 2000; Sadhukhan et al., 2003), economics (Rycroft and Kash, 1999), mathematics (McCabe, 1976; Bläser, 2003), computer science (Werschulz and Woźniakowski, 2002), ecosystems (Zorach and Ulanowicz, 2003).

Klir (1985) noted that commonsense definitions of complexity from *Webster's Third International Dictionary* are as follow:

1. Having many varied interrelated parts, patterns, or elements and consequently hard to understand fully;
2. Being marked by an involvement of many parts, aspects, details, notions, and necessitating earnest study or examination to understand or cope with.

Other definitions of complexity can be found in several other research areas:

1. Complexity is the lack of connectedness in the system (Casti, 1979);



2. Extrapolating from various different contexts in which the idea of complexity is used, a complex system may refer to one whose static structure or dynamic behavior is counterintuitive or unpredictable (Casti, 1979);
3. In general, we seem to associate complexity with anything we find difficult to understand (Flood and Carson, 1988);
4. Complex systems are typically organizations made of many heterogeneous parts interacting locally in the absence of a centralized pacemaker and control. Think, for example, of the economy, the brain, cellular metabolism, or the Los Angeles traffic basin. It may be easy to describe a system's composition, but it is far more difficult to describe its global behavior (Fontana and Ballati, 1999).

It may also refer to a system which has patterns of connections among subsystems such that the prediction of system behavior is difficult without substantial analysis or computation, or one in which the decision making structures make the effects of individual choices difficult to evaluate (Löfgren, 1977).

Although many writers on the subject understand qualitatively similar things by the term "complexity", a transition from this qualitative understanding to a quantitative approach would be highly desirable and necessary step towards founding the science of manufacturing complexity (Calinescu et al., 2000).

The lack of understanding in this area has hindered planners in deciding how much integration is beneficial and beyond which point integration is actually detrimental to system performance, since correct decisions are difficult to make due to high system complexity (Deshmukh et al., 1998).

According to Deshmukh et al. (1998), the complexity of a physical system can be

characterized in terms of its static structure or time dependent behavior. Static complexity can be viewed as a function of the structure of the system, connective patterns, variety of components, and the strengths of interactions. Dynamic complexity is concerned with unpredictability in the behavior of the system over a time period.

Frizelle and Woodcock (1995) first applied the entropy based theoretical measure of complexity for internal manufacturing input-output systems. Their work includes a mathematical model that provides a measure for the complexity of material flow found within a manufacturing operation, from the point of view of a product moving through a system. This paper reports on the further developments of applying the theoretical concept of entropy (Fast, 1970) from its theoretical and mathematical basis to its practical application in measuring both information and material complexity within the supply chain.

According to Deshmukh et al. (1998): "Another important consequence of developing an analytical framework for complexity would be to assist manufacturing planners in managing desired levels of complexity in the system, since realistically it cannot be eliminated, depending on the changing operating conditions". Although this was written for manufacturing processes, it is applicable for control also.

According to Nett (1989) the more complex the control system is, the more it costs, the less reliable it is, and the harder it is to maintain it. Then is generally desirable that the complexity of the control system and, in particular, of the regulatory control layer be as small as possible (Skogestad, 2003).

The objective of this paper is to present a method to quantify the complexity of a block diagram that can be useful for process control structure studies.



## 2. MATHEMATICAL DEFINITIONS OF BLOCK COMPLEXITY

Skogestad (2003) introduces a structural complexity number  $\Pi_s$  as:

$$\Pi_s = \# \text{measurements} + \# \text{manipulators} + \underbrace{\# \text{blocks} + \# \text{control-parameters}}_{\text{block diagram complexity } (C_b)} \quad (1)$$

where the number of measurements and manipulators refers to the ones used by the independent controller. The block complexity is the number of blocks plus the number of independent tunable control parameters. In this case a multivariable block is counted as having complexity 1. The problem in counting multivariable blocks as having complexity 1 is that we do not consider the complexity inside the block. This result can be sometimes misleading.

In this section we present two possible mathematical definitions of block complexity ( $\# \text{blocks} + \# \text{control-parameters}$  from Equation 1) that can be useful for control structure studies.

### 2.1 Definition 1 (including summation blocks)

To calculate the complexity of a block diagram we will consider that we only have SISO systems (in this case we will consider that all MIMO systems can be represented by a set of SISO systems). The calculation of the complexity involves the number of flows that enter in a sum block and the number of independent tunable parameters of the system (constants are not considered, e.g., fixed values, unit conversions, scaling). The complexity of block  $i$  is given by:

$C_{b,i} = \# \text{parameters} - \# \text{sum-blocks} + \text{number of flows} =$

$$n_{p,i} + \sum_{j=1}^{n_{s,i}} (F_{j,i} - 1) = n_{p,i} - n_{s,i} + \sum_{j=1}^{n_{s,i}} F_{j,i} \quad (2)$$

where:

$n_{p,i}$  is the number of independent parameters inside the block  $i$

$n_{s,i}$  is the number of sum blocks inside the block  $i$

$F_{j,i}$  is the number of flows (inside block  $i$ ) that enter in the sum block  $j$

The total complexity of the system is the sum of the complexities of each block plus the number of flows that enter in sum blocks and don't belong to any other block:

$$C_s = \sum_{i=1}^{n_b} C_{b,i} + \sum_{j=1}^{n_s} (F_j - 1) = \sum_{i=1}^{n_b} C_{b,i} + \sum_{j=1}^{n_s} F_j - n_s \quad (3)$$

where:

$n_b$  is the number of blocks of the system

$n_s$  is the number of sum blocks of the system

$F_j$  is the number of flows that enter in the sum block  $j$

The total complexity for systems without feedback can be interpreted as the total number of parameters plus the total number of basic operations (sum, subtraction, multiplication, and division). If, in our diagram, we have other operations as sin, log, or more complex functions, these operations would have larger complexity, but this is not the scope of this paper.

### 2.2 Definition 2 (including splitting blocks)

Another possible definition of the complexity of a block diagram is the inclusion of splitting blocks instead of summation blocks. In this case, the complexity is defined as:

$$C_{b,i} = n_{p,i} + \sum_{j=1}^{n_{sp,i}} (F_{j,i}^* - 1) = n_{p,i} - n_{sp,i} + \sum_{j=1}^{n_{sp,i}} F_{j,i}^* \quad (4)$$

where:

$n_{sp,i}$  is the number of splitting blocks inside the block  $i$

$F_{j,i}^*$  is the number of flows (inside block  $i$ ) that enter in the splitting block  $j$

The total complexity is:

$$C_s = \sum_{i=1}^{n_b} C_{b,i} + \sum_{j=1}^{n_{sp}} (F_j^* - 1) = \sum_{i=1}^{n_b} C_{b,i} + \sum_{j=1}^{n_{sp}} F_j^* - n_{sp} \quad (5)$$

where:

$n_b$  is the number of blocks of the system

$n_{sp}$  is the number of sum blocks of the system

$F_j^*$  is the number of flows that enter in the sum block  $j$

### 3.EXAMPLES

In this section we will present some examples to show the importance of the block diagram complexity and to compare both definitions.

Example 1: Consider Figure 1.

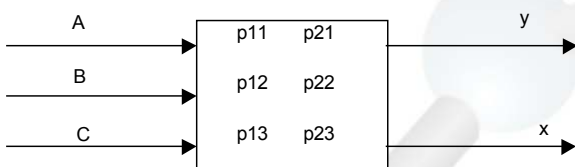

Figure 1 – Multivariable block diagram

This is a multivariable block diagram. If we calculate the complexity of this system without looking inside the multivariable block, the result would be equal to 7 (six independent parameters and 1 multivariable block). Although this could be considered a good result, in the last section was assumed that the complexity measure can be calculated only for

block diagrams with SISO blocks. Then, to be able to evaluate its complexity, it is necessary to know what happens inside this block (what are the relations between the inputs and the outputs). Figure 2 gives two possible relations between the inputs and the outputs.

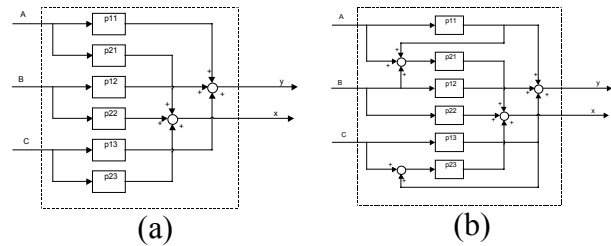

Figure 2 - 2 possible block representations of Figure 1.

Figures 2a and 2b are represented by Equations 6 and 7, respectively:

$$\begin{aligned} y &= p_{11}A + p_{12}B + p_{13}C \\ x &= p_{21}A + p_{22}B + p_{23}C \end{aligned} \quad (6)$$

$$\begin{aligned} y &= p_{11}A + p_{12}B + p_{13}C \\ x &= p_{21}(1 + p_{21})A + (p_{21} + p_{22})B + p_{23}(1 + p_{23})C \end{aligned} \quad (7)$$

The complexity of these two block diagrams are: for Figure 2a the number of parameters is equal to 6 ( $n_{p,i} = 6$ ), the number of sum blocks is equal to 2 ( $n_{s,i} = 2$ ), the number of splitting blocks is equal to 3 ( $n_{sp,i} = 3$ ), and there are 6 flows entering in the sum blocks ( $\sum_{j=1}^{n_{s,i}} F_{j,i} = 6$ ) and 6 flows leaving

the splitting blocks ( $\sum_{j=1}^{n_{sp,i}} F_{j,i}^* = 6$ ). Then the complexity number of this block is equal to 10 (definition 1) or 9 (definition 2). Doing the same calculation for Figure 2b

( $n_{p,i} = 6$ ,  $n_{s,i} = 4$ ,  $n_{sp,i} = 6$ ,  $\sum_{j=1}^{n_s} F_{j,i} = 11$ , and  $\sum_{j=1}^{n_{sp,i}} F_{j,i}^* = 12$ ) the resulting block complexity is equal to 13 (definition 1) and 12 (definition 2).



In general the block representation of Figure 1 is Figure 2a. In this case or when we don't know exactly how is structure inside the MIMO block, there is a easier way to estimate the complexity of this block for definitions 1 and 2, respectively:

$$C_{b,i} = (2n_{i,i} - 1)n_{o,i} \quad (8)$$

$$C_{b,i} = (2n_{o,i} - 1)n_{i,i} \quad (9)$$

where  $n_{i,i}$  is the number of inputs of block  $i$  and  $n_{o,i}$  is the number of outputs of block  $i$

Example 2: For a more complex example consider the system presented in Figure 3

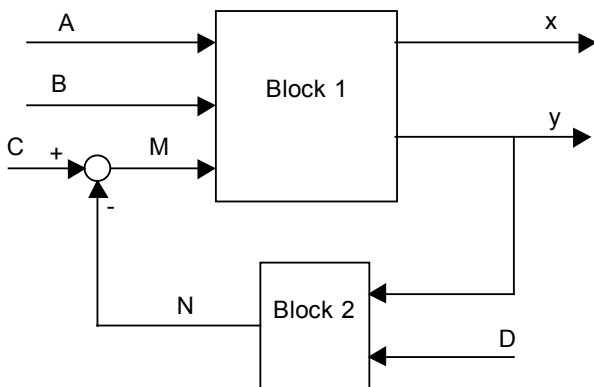

Figure 3 - Block diagram with two separated MIMO blocks.

The global complexity of the system represented by Figure 3 is the sum of the complexities of blocks 1 and 2 and the sum block. Blocks 1 and 2 are detailed in Figure 4.

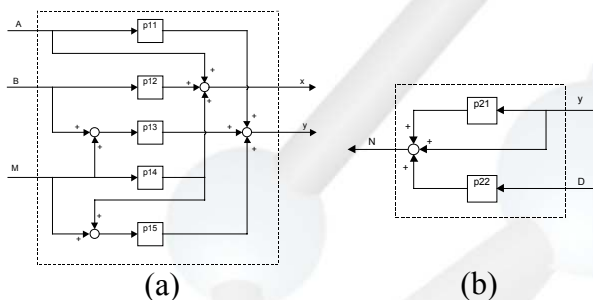
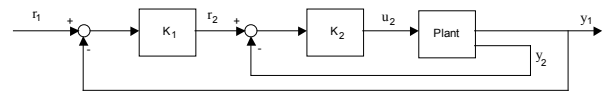

Figure 4 - Representation of blocks 1 (a) and 2 (b) from Figure 3.

If we don't consider what is inside the blocks in Figure 3 we obtain a complexity of 7 (block 1) and 3 (block 2), 2 flows entering a sum block and 2 leaving a splitting block. Then the total complexity would be 11 for both definitions.

But, when we look inside the blocks 1 and 2 (see Figure 4), we see that the complexity for block 1 is 11 (definition 1) and 10 (definition 2) and for block 2 is 4 (definition 1) and 3 (definition 2). Then the total complexity of the system represented by Figure 3 is 16 (definition 1) and 14 (definition 2).

Example 3: In this example we will apply the suggested complexity measures to some blocks diagrams presented by Skogestad and Postlethwaite (1996). Figures 5a and b, 6, 7, and 8 are the Figures 10.3a and b, 10.4, 10.5, and 10.8, respectively.



(a) Conventional cascade control (extra measurements  $y_2$ )

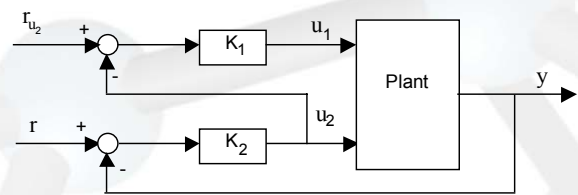

(b) Input resetting (extra inputs  $u_2$ )

Figure 5 - Cascade implementations

Figure 5 presents two typical control configurations with extra measurements (a) and extra manipulators (b). The advantage of the conventional cascade implementation is that it more clearly decouples the design of the two controllers.

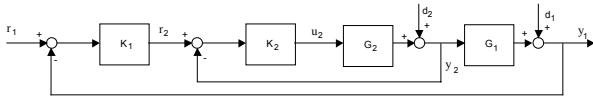

Figure 6 - Common case of cascade control where the primary output  $y_1$  depends directly on the extra measurement  $y_2$ .

The complexities of Figures 5-8 are presented in Table 1, as well as the complexities of the other examples. For each figure is presented the complexity using both definitions.

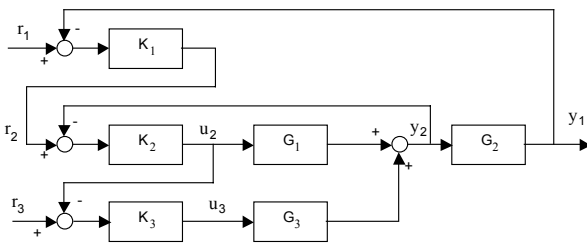

Figure 7 - Control configuration with two layers of cascade control.

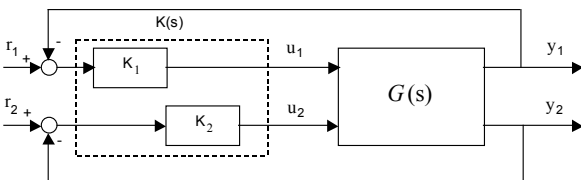

Figure 8 - Decentralized diagonal control of a  $2 \times 2$  plant.

Table 1 - Comparison between complexity definitions 1 and 2.

Examples	Definition 1	Definition 2
Figure 2a	10	9
Figure 2b	13	12
Figures 3 and 4	16	14
Figure 5a	5	4
Figure 5b	5	5
Figure 6	8	6
Figure 7	10	9
Figure 8	5	5

Table 1 shows that both definitions are equivalent. The difference is basically

which one can be considered more important in the complexity measure, summation or splitting blocks. It is important to notice that we should use only one of them, never both at the same time. It is important to remember that we cannot compare the complexity of two structures calculated by two different definitions. In this case we must choose one definition and use it for all structures.

#### 4. APPLICATION TO PERFECT INDIRECT CONTROL

An important application of the complexity measure is in the use of perfect indirect control. Skogestad et al. (2003) have shown that it is possible to obtain perfect indirect control if we have enough measurements and keep constant a combination of them. If we have the following linear model:

$$\Delta \mathbf{y}_1 = \mathbf{G}_1 \Delta \mathbf{u} + \mathbf{G}_{d1} \Delta \mathbf{d} \quad (10)$$

$$\Delta \mathbf{y} = \mathbf{G}^y \Delta \mathbf{u} + \mathbf{G}_d^y \Delta \mathbf{d} \quad (11)$$

where:

$\Delta \mathbf{y}_1$  - primary variables (combination of the states)

$\Delta \mathbf{y}$  - available measurements

$\Delta \mathbf{u}$  - manipulated variables

$\Delta \mathbf{d}$  - disturbances

They proved that, having enough measurements, we have perfect indirect control if we combine the measurements in the following way:

$$\Delta \mathbf{c} = \mathbf{H} \Delta \mathbf{y} = \underbrace{\mathbf{H} \mathbf{G}^y}_{\mathbf{G}} \Delta \mathbf{u} + \underbrace{\mathbf{H} \mathbf{G}_d^y}_{\mathbf{G}_d} \Delta \mathbf{d} \quad (12)$$

where:

$\Delta \mathbf{c}$  - combination of measurements (secondary outputs)

$\mathbf{H}$  - matrix of the combination of variables

The solution for this problem is given by Equation 13:

$$\mathbf{H} = \mathbf{P}_{c0}^{-1} \underbrace{\begin{bmatrix} \mathbf{G}_1 & \mathbf{G}_{d1} \end{bmatrix}}_{\hat{\mathbf{G}}_1} \underbrace{\begin{bmatrix} \mathbf{G}^y & \mathbf{G}_d^y \end{bmatrix}}_{\hat{\mathbf{G}}^{y-1}} \quad (13)$$

where  $\mathbf{P}_{c0}$  is a matrix that relates the combination of measurements to the primary inputs. This matrix can be arbitrarily chosen.

The problem in this approach is that the resulting  $\mathbf{H}$  matrix is a full matrix, making the control structure too complex. To reduce the complexity of this control structure keeping the property of perfect disturbance rejection we will divide the  $\mathbf{H}$  matrix in two parts ( $\mathbf{H} = [\mathbf{H}_1 \quad \mathbf{H}_2]$ ), where  $\mathbf{H}_1$  is a square matrix. If we want  $\mathbf{H}_1$  to equal to identity matrix (to reduce the complexity), we should also divide the following matrices:

$$\mathbf{G}^y = \begin{bmatrix} \mathbf{G}^{y_1} \\ \mathbf{G}^{y_2} \end{bmatrix} \quad \mathbf{G}_d^y = \begin{bmatrix} \mathbf{G}_d^{y_1} \\ \mathbf{G}_d^{y_2} \end{bmatrix} \quad (14)$$

where  $\mathbf{G}^{y_1}$  is a square matrix.

Joining Equations 13 and 14, and isolating  $\mathbf{H}_1$  and  $\mathbf{H}_2$ , results in:

$$\mathbf{H}_1 = \mathbf{P}_{c0}^{-1} \left[ \mathbf{G}_1 - (\mathbf{G}_{d1} - \mathbf{G}_1 \mathbf{G}^{y_1} \mathbf{G}_d^{y_1}) (\mathbf{G}_d^{y_2} - \mathbf{G}^{y_2} \mathbf{G}^{y_1} \mathbf{G}_d^{y_1})^{-1} \mathbf{G}^{y_2} \right] \mathbf{G}^{y_1} \quad (15)$$

$$\mathbf{H}_2 = \mathbf{P}_{c0}^{-1} (\mathbf{G}_{d1} - \mathbf{G}_1 \mathbf{G}^{y_1} \mathbf{G}_d^{y_1}) (\mathbf{G}_d^{y_2} - \mathbf{G}^{y_2} \mathbf{G}^{y_1} \mathbf{G}_d^{y_1})^{-1} \quad (16)$$

If  $\mathbf{P}_{c0}$  is considered as been (it can be arbitrarily chosen):

$$\mathbf{P}_{c0} = \left[ \mathbf{G}_1 - (\mathbf{G}_{d1} - \mathbf{G}_1 \mathbf{G}^{y_1} \mathbf{G}_d^{y_1}) (\mathbf{G}_d^{y_2} - \mathbf{G}^{y_2} \mathbf{G}^{y_1} \mathbf{G}_d^{y_1})^{-1} \mathbf{G}^{y_2} \right] \mathbf{G}^{y_1} \quad (17)$$

then we can conclude that  $\mathbf{H}_1 = \mathbf{I}$ .

By Equation 17 we can easily verify that this solution is unique, i.e., there is only

one matrix  $\mathbf{P}_{c0}$  and, consequently, only one matrix  $\mathbf{H}_2$  that results in  $\mathbf{H}_1 = \mathbf{I}$ .

To compare the complexity of the control structures given by these two ways to calculate the  $\mathbf{H}$  matrix we will use the example of the distillation column presented by Skogestad et al. (2003). In this example they combine the flow rates ( $L$ ,  $V$ ,  $D$ , and  $B$ ) as measurements, then the original combination of variables (with full matrix  $\mathbf{H}$ ) is represented by:

$$\begin{aligned} c_1 &= h_{11}L + h_{12}V + h_{13}D + h_{14}B \\ c_2 &= h_{21}L + h_{22}V + h_{23}D + h_{24}B \end{aligned} \quad (18)$$

This control structure has complexity equal to 14 (definition 1) or 12 (definition 2). The second combination of variables (imposing  $\mathbf{H}_1$  equal to identity) is:

$$\begin{aligned} c_1 &= L + h_{13}^*D + h_{14}^*B \\ c_2 &= V + h_{23}^*D + h_{24}^*B \end{aligned} \quad (19)$$

This control structure has complexity equal to 8 (using definition 1) or 6 (using definition 2). Independently of which definition we use, we demonstrated by this example that it is important to obtain control structures with the same characteristics (perfect disturbance rejection) but with reduced complexity.

## 5. CONCLUSIONS

This paper presented two similar ways to evaluate the complexity of block diagrams. The importance of this evaluation is to help to produce good control structures with the smaller possible complexity due to the fact that the costs of implementation increase in large complex systems.

Independently of the choice of the definition, to be able to compare two different structures the designer must always use the



same definition. An important point to emphasize is that although we can count either summation or splitting blocks, we shouldn't use both at the same time because, in doing this, we are counting twice.

It was also shown that it is possible to obtain a perfect indirect control with minimum complexity.

## 6. REFERENCES

- BEN-HUR, A.; SIEGELMANN, H. T.; FISHMAN, S. A theory of complexity for continuous time systems. *J. Complex.*, v. 18, p.51-86, 2002.
- BLÄSER, M. On the complexity of the multiplication of matrices of small formats. *J. Complex.*, v. 19, p. 43-60, 2003.
- CALINESCU, A.; EFSTATHIOU, J.; SIVADASAN, S.; SCHIRN, J.; HUATUCO, L. H. Complexity in manufacturing: an information theoretic approach. *Proc. Int. Conf. Complex Syst. and Complexity in Manuf., Warwick University, 2000.*
- CASTI, J. Connectivity, complexity, and catastrophe in large-scale systems. New York: John Wiley, 1979.
- DESHMUKH, A. V.; TALAVAGE, J. J.; BARASH, M. M. Complexity in manufacturing systems, Part 1: Analysis of static complexity. *IIE Trans.*, v. 30, p. 645-655, 1998.
- FAST, J. D. Entropy. London: Macmillan, second edition, 1970.
- FLOOD, R. L.; CARSON, E. R. Dealing with complexity. Plenum Press, 1998.
- FONTANA, W.; BALLATI, S. Complexity. *Complexity*, v. 4, n. 3, p. 14-16, 1999.
- FRIZELLE, G.; WOODCOOK, E. Measuring complexity as an aid to developing operational strategy. *Int. J. Oper. Prod. Manag.*, v. 15, n. 5, p. 26-39, 1995.
- KLIR, G. J. Complexity: some general observations. *Syst. Res.*, v. 2, n. 2, p. 131-140, 1985.
- LÖFGREN, L. Complexity of descriptions of systems. *Int. J. Gen. Syst.*, v. 3, p. 197-214, 1977.
- McCABE, T. J. A complexity measure. *IEEE Trans. Soft. Eng.*, v. SE-2, n. 4, p. 308-320, 1976.
- NETT, C.N.; BERNSTEIN, D. S.; HADDAD, W. M. Minimal complexity control law synthesis, part 1: problem formulation and reduction to optimal static output feedback. *Proc. ACC*, p. 2056-2064, 1989.
- RYCROFT, R. W. The complexity challenge: technological innovation for the 21<sup>st</sup> century. Pinter, 1999.
- SADHUKHAN, J.; ZHANG, N.; ZHU, X. X. Value analysis of complex systems and industrial application to refineries. *Ind. Eng. Chem. Res.*, v. 42, p. 5165-5181, 2003.
- SKOGESTAD, S. Control structure design for complete chemical plants. *Comp. Chem. Eng.*, v. 28, p. 219-234, 2003.
- SKOGESTAD, S.; HORI, E. S.; ALSTAD, V. Perfect indirect control, 2003. (unpublished)
- SKOGESTAD, S.; POSTLETHWAITE I. Multivariable Feedback Control. John Wiley & Sons, 1996.
- WERSCHULZ, A. G.; WOŹNIAKOWSKI, H. What is the complexity of volume calculation? *J. Complex.*, v. 18, p. 660-678, 2002.
- ZORACH A. C.; ULANOWICZ, R. E. Quantifying the complexity of flow networks: How many roles are there? *Complexity*, v. 8, n. 3, p. 68-76, 2003.

## 7. ACKNOWLEDGMENTS

The financial support of The National Council for Scientific and Technological Development (CNPq/Brasil) and Coordenação de Aperfeiçoamento de Pessoal de Nível Superior (CAPES/Brasil) is gratefully acknowledged.