

Buffer Tank Design for Acceptable Control Performance

Audun Faanes[†] and Sigurd Skogestad*

Department of Chemical Engineering, Norwegian University of Science and Technology, N-7491 Trondheim, Norway

This paper provides a systematic approach for the design of buffer tanks. We consider mainly the case where the objective of the buffer tank is to dampen (“average out”) the fast (i.e., high-frequency) disturbances, which cannot be handled by the feedback control system. We consider separately design procedures for (I) mixing tanks to dampen quality disturbances and (II) surge tanks with averaging level control to handle flow-rate disturbances.

1. Introduction

Buffer tanks are common in industry, under many different names, such as intermediate storage vessels, holdup tanks, surge drums, accumulators, inventories, mixing tanks, continuous stirred tank reactors (CSTRs), and neutralization vessels. We start with a definition:

A buffer tank is a unit where the holdup (volume) is exploited to provide smoother operation.

We here focus on buffer tanks for liquids, although most of the results may be easily extended to gas- or solid-phase systems. Buffer tanks may be divided into two categories, namely, for (A) disturbance attenuation and (B) independent operation:

A. Buffer tanks are installed between units to avoid propagation of disturbances for continuous processes.

B. Buffer tanks are installed between units to allow independent operation, for example, during a temporary shutdown and between continuous and batch process units.

In this category there is a continuous delivery or outdraw on one side and a discontinuous delivery or outdraw on the other side. The design of the tank size for these types of buffer tanks is often fairly straightforward (typically equal to the batch volume) and is not covered further in this paper.

In this paper we focus on category A. There are two fundamentally different disturbances, namely, in quality and flow rate, and two approaches to dampen them (see Figure 1):

I. Quality disturbances, e.g., in concentration or temperature, where we dampen by mixing. Such buffer tanks are often called mixing tanks or neutralization vessels for pH processes.

II. Flow-rate disturbances, e.g., in the feed rate, where we dampen by temporarily changing the volume (level variation). Such buffer tanks are often called surge tanks, intermediate storage vessels, holdup tanks, surge drums, accumulators, or inventories.

In both cases the tank volume is exploited, and a larger volume gives better dampening: In the first case, mixing of a larger volume means that the in-flow

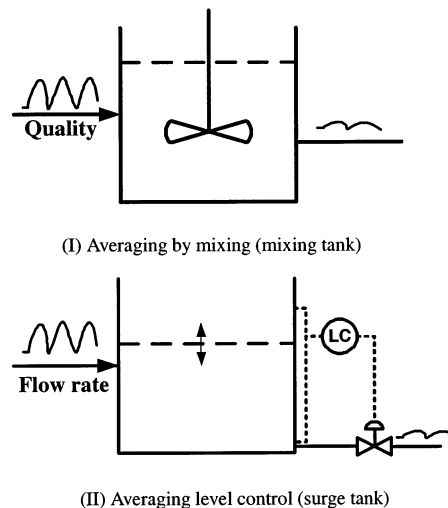

Figure 1. Two types of buffer tanks.

entering during a longer period is mixed together, and in the second case, larger level variations are allowed.

Often, in the design of buffer tanks, the residence or hold-up time is used as a measure instead of the volume. The residence time is defined as $\tau = V/q$, where V is the volume [m³] and q the nominal flow rate [m³/s].

Even if the buffer tanks are designed and implemented for control purposes, control theory is rarely used when sizing and designing the tanks. Instead, rules of thumb are used. For example, textbooks on chemical process design seem to agree that a half-full residence time of 5–10 min is appropriate for distillation reflux drums and that this also applies for many other buffer (surge) tanks. For tanks between distillation columns, a half-full residence time of 10–20 min is recommended.^{1–5}

Sigales⁶ sets the total residence time as the sum of the surge time and a possible settling time. The following surge times are recommended: distillation reflux, 5 min; product to storage, 2 min; product to heat exchanger or other process streams, 5 min; product to heater, 10 min. The settling time applies when there is an extra liquid phase. For water in hydrocarbons, a settling time of 5 min is proposed.

None of the above references provide any justifications for their rules.

The most complete design procedure for reflux drum volumes is presented by Watkins,⁷ who proposes a half-full volume given by

* To whom correspondence should be addressed. Tel.: +47 73 59 41 54. Fax: +47 73 59 40 80. E-mail: skoge@chemeng.ntnu.no.

[†] Also affiliated with Corporate Research Centre, Norsk Hydro ASA, N-3907 Porsgrunn, Norway. Tel.: +47 35 92 40 21. Fax: +47 35 92 32 63. E-mail: audun.faanes@hydro.com.

$$V = (f_1 + f_2)(L + f_3 D)f_4 \quad (1)$$

Here f_1 (typical range 0.5–2) and f_2 (typical range 1–2) are instrumentation and labor factors, respectively, related to buffer tanks of category B mentioned above. For example, the value of f_2 may be based on how much time it takes for the operator to replace a disabled pump. L and D are reflux and product rates, and the factor f_3 (typical range 1.25–4) is dependent on how well external units are operated (e.g., 1.25 for product to storage). f_4 (typical range 1–2) is a level indicator factor. The method gives half-full hold-up times from 1.5 to 32 min.

In addition to the volumes proposed above, one normally adds about 10% of the volume to prevent overflowing.⁵ For reflux drums, 25–50% extra volume for the vapor is recommended.²

A basic guide to the design of mixing tanks is given by ref 8.

The process control literature refers to the level control of buffer tanks for flow-rate dampening (surge tanks) as *averaging level control*. Harriott,⁹ Hiester et al.,¹⁰ and Marlin¹¹ propose controller and tank size designs that are based on specifying the maximum allowed change in the flow rate out of the buffer (surge) tank because this flow acts as a disturbance for the downstream process. However, no guidelines are given for the critical step of specifying the outlet flow-rate change. Otherwise, these methods have similarities with the one proposed in the present paper.

To reduce the effect of the material balance control on the quality control loop, Buckley¹² recommends designing the buffer tank such that the material balance control can be made 10 times slower than the quality loop. In practice, this means that the effect of the disturbance on the quality at the worst-case frequency is reduced by a factor of 10. This applies to both surge and mixing tanks.

There have also been proposals for optimal averaging level control, e.g.,¹³ where the objective is to find the controller that essentially gives the best disturbance dampening for a given surge tank. To reduce the required surge tank volume, provided one is willing to accept rare and short large changes in the outlet flow, one may use a nonlinear controller that works as an averaging controller when the flow changes are small but where the nonlinear part prevents the tank from being completely empty or full.^{13–15}

Another related class of process equipment is neutralization tanks. Neutralization is a mixing process of two or more liquids of different pH. Normally this takes place in one or more buffer (mixing) tanks in order to dampen variations in the final product. The process design for neutralization is discussed by Shinsky¹⁶ and McMillan.¹⁷ Another design method and a critical review on the design and control of neutralization processes with emphasis on chemical wastewater treatment is found in ref 18. In ref 19 tank size selection for neutralization processes is discussed.

Zheng and Mahajanam²⁰ propose the use of the necessary buffer tank volume as a controllability measure.

The objective of this paper is to answer the following questions: When should a buffer tank be installed to avoid propagation of disturbances, and how large should the tank be? The preferred way of dealing with disturbances is feedback control. Typically, with integral feedback control, perfect compensation may be achieved

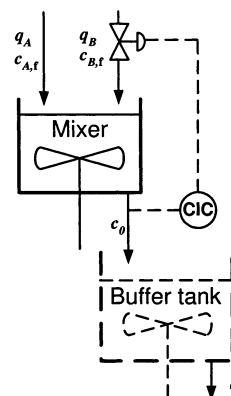

Figure 2. Mixing process. The concentration is controlled by manipulating the flow rate of stream B. Variations are further dampened by an extra buffer tank.

at steady state. However, because of inherent limitations such as time delays, the control system is generally not effective at higher frequencies, and the process itself (including any possible buffer tanks) must dampen high-frequency disturbances. We have the following:

The buffer tank [with transfer function $h(s)$] should modify the disturbance, d , such that the modified disturbance

$$d'(s) = h(s) d(s) \quad (2)$$

can be handled by the control system. The buffer tank design problem can be solved in two steps:

Step 1. Find the required transfer function $h(s)$. [Typically, $h(s) = 1/(\tau s + 1)^n$, and the task is to find the order n and the time constant τ .]

Step 2. Find a physical realization of $h(s)$ (tank volume V and possibly level control tuning).

In this paper we present design methods for buffer tanks based on this fundamental insight.

2. Introductory Example

The following example illustrates how we may use (1) the control system and (2) a buffer (mixing) tank to keep the output within its specified limits despite disturbances.

Example 1. Consider the mixing of two process streams, A and B, with different components (also denoted A and B), as illustrated in Figure 2.

The objective is to mix equal amounts of A and B such that the excess concentration of the outlet flow $c_0 = c_A - c_B$ is close to zero. More specifically, we require c_0 to stay within 0 ± 1 mol/m³. The combined component and total material balance gives the following model:

$$\frac{dc_0}{dt} = \frac{1}{V}[(c_{A,f} - c_0)q_A + (c_{B,f} - c_0)q_B] \quad (3)$$

For the case with no control and no buffer tank, the time response in the outlet concentration, $y = c_0$, to a step disturbance in the feed concentration, $d = c_{A,f}$, is shown by the solid line (“Original”) in Figure 3. The value of $y = c_0$ approaches 10 mol/m³, which is 10 times larger than the accepted value.

1. We first design a feedback control system, based on measuring $y = c_0$ and manipulating $u = q_B$ to counteract the disturbance. We choose a proportional–integral (PI) composition controller, $K_{CIC}(s) = 0.01(s + 1)/s$. Note that the speed of the control system

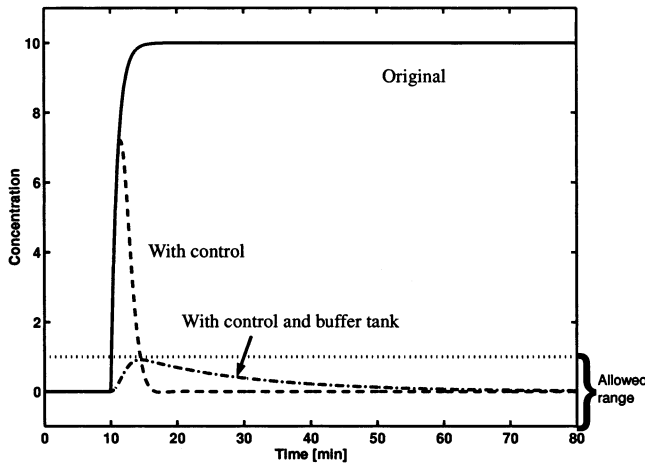

Figure 3. Response of the excess outlet concentration to a step in inlet quality (from 100 to 120 mol of A/m³ at 10 min) for the system in Figure 2. A composition controller handles the long-term (“slow”) disturbance, but a buffer tank is required to handle the short-term deviations. Nominal data: $q_A = 0.5$ m³/min, $q_B = 0.5$ m³/min, $c_A = 100$ mol of A/m³, $c_B = 100$ mol of B/m³, $c_0 = 0$ mol of A – B/m³. Residence time mixer: 1 min. Delay in control loop $\theta = 1$ min. The levels in the mixer and the buffer tank are controlled by adjusting the outflow with PI controllers, $k(s) = (50s + 1)/50s$.

is limited by an effective delay $\theta = 1$ min, mainly due to the concentration measurement. The resulting response with control is shown by the dashed line. Because the controller has integral action, the outlet concentration returns to its desired value of 0 mol/m³. However, because of the delay, the initial deviation is still unacceptable.

2. To deal with this, we install, in addition, a buffer tank with volume 19 m³ (residence time 19 min) (drawn with dashed lines in Figure 2). We are now able to keep the outlet concentration c within its limit of ± 1 mol/m³ at all times as shown by the dash-dotted line in Figure 3.

Instead of the buffer tank, we could have installed a feedforward controller, but this requires a fast (and accurate) measurement of the disturbance, $d = c_{A,f}$, and a good process model. In practice, it would be very difficult to make this work for this example.

Comment on notation: Throughout the paper, the main feedback controller for the process is denoted $K(s)$, whereas the buffer tank level controller is denoted $k(s)$.

In the following sections we will show how to design buffer tanks for quality disturbances, like in the above example, as well as for flow-rate disturbances.

3. Step 2: Physical Realization of $h(s)$ with a Buffer Tank

Consider the effect of a disturbance, d , on the controlled variable y . Without any buffer tank, the linearized model in terms of deviation variables may be written as

$$y(s) = G_{d_0}(s) d(s) \quad (4)$$

where G_{d_0} is the original disturbance transfer function (without a buffer tank). To illustrate the effect of the buffer tank, we let $h(s)$ denote the transfer function for the buffer tank. The disturbance passes through the buffer tank. With a buffer tank, the model becomes (see Figure 4)

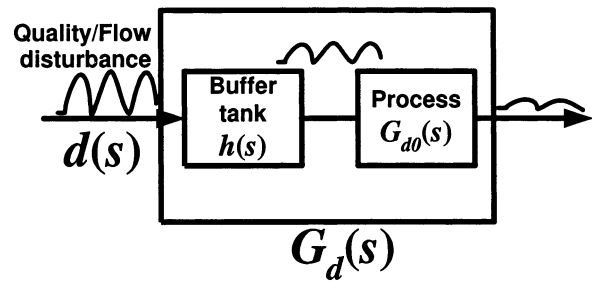

Figure 4. Use of buffer tank to dampen the disturbance.

$$y(s) = \underbrace{G_{d_0}(s) h(s)}_{G_d(s)} d(s) \quad (5)$$

where $G_d(s)$ is the resulting modified disturbance transfer function. A typical buffer tank transfer function is

$$h(s) = \frac{1}{(\tau s + 1)^n} \quad (6)$$

Note that $h(0) = 1$ so that the buffer tank has no steady-state effect.

We will now consider separately how transfer functions $h(s)$ of the form (6) arise for (I) quality and (II) flow-rate disturbances. In both cases, we consider a buffer tank with liquid volume V [m³], inlet flow rate q_{in} [m³/s], and outlet flow rate q [m³/s].

I. Mixing Tank for Quality Disturbance ($d = c_{in}$). Let c_{in} denote the inlet quality and c the outlet quality (for example, concentration or temperature). For quality disturbances, the objective of the buffer tank is to smoothen the quality response

$$c(s) = h(s) c_{in}(s) \quad (7)$$

so that the variations in c are smaller than those in c_{in} . A component or simplified energy balance for a *single* perfectly mixed tank yields $d(Vc)/dt = q_{in}c_{in} - qc$. By combining this with the total material balance $dV/dt = q_{in} - q$ (assuming constant density), we obtain $V dc/dt = q_{in}(c_{in} - c)$, which upon linearization and taking the Laplace transform yields

$$c(s) = \frac{1}{\frac{V^*}{q^*}s + 1} \left[c_{in}(s) + \frac{c_{in}^* - c^*}{q^*} q_{in}(s) - \frac{c_{in}^* - c^*}{V^*} V(s) \right] \quad (8)$$

where an asterisk denotes the nominal (steady-state) values and the Laplace variables $c(s)$, $c_{in}(s)$, $q_{in}(s)$, and $V(s)$ now denote deviations from the nominal values. We note that flow-rate disturbances (in q_{in}) may result in quality disturbances if we mix streams of different compositions (so that $c_{in}^* \neq c^*$). From (8), we find that the transfer function for the tank is

$$h(s) = \frac{1}{\tau s + 1} \quad (9)$$

where $\tau = V^*/q^*$ [s] is the nominal residence time. We note that the buffer (mixing) tank works as a first-order filter. Similarly, for n tanks in series, we have

$$h(s) = \frac{1}{\prod_{i=1}^n (\tau_i s + 1)} \quad (10)$$

where τ_i = residence time in tank i . We find the required volume of each tank from $V_i = \tau_i q_i^*$, where q_i^* is the nominal flow rate through tank i .

II. Surge Tank for Flow-Rate Disturbance ($d = q_{in}$). For flow-rate disturbances, the objective is to use the buffer volume to smoothen the flow-rate response

$$q(s) = h(s) q_{in}(s) \quad (11)$$

The total mass balance assuming constant density yields

$$\frac{dV}{dt} = q_{in} - q \quad (12)$$

We want to use an “averaging level control” with a “slow” level controller because tight level control yields $dV/dt \approx 0$ and $q \approx q_{in}$. Let $k(s)$ denote the transfer function for the level controller including measurement and actuator dynamics and also the possible dynamics of an inner flow control loop. Then

$$q(s) = k(s) [V(s) - V_s(s)] \quad (13)$$

where V_s is the setpoint for the volume. Combining this with (12) and taking Laplace transforms yields

$$V(s) = \frac{1}{s + k(s)} [q_{in}(s) + k(s) V_s(s)] \quad (14)$$

or from (13)

$$q(s) = \frac{k(s)}{s + k(s)} [q_{in}(s) - sV_s(s)] \quad (15)$$

The buffer (surge) tank transfer function is thus given by

$$h(s) = \frac{k(s)}{s + k(s)} = \frac{1}{\frac{s}{k(s)} + 1} \quad (16)$$

With a proportional controller, $k(s) = k_c$, we get that $h(s)$ is a first-order filter with $\tau = 1/k_c$. Alternatively, for a given $h(s)$, the resulting controller is

$$k(s) = \frac{sh(s)}{1 - h(s)} \quad (17)$$

Compared to the quality disturbance case, we have more freedom in selecting $h(s)$ because we can quite freely select the controller $k(s)$. However, the liquid level will vary, so the size of the tank must be chosen so that the level remains between its limits. The volume variation is given by (14), which upon combination with (17) yields

$$V(s) = \frac{1 - h(s)}{s} q_{in}(s) \quad (18)$$

Table 1. Averaging Level Control: Design Procedure II for Flow-Rate Disturbances for Alternative Choices of $h(s)$

step	first order	second order	n th order
2.1. desired $h(s)$ (from step 1)	$\frac{1}{\tau s + 1}$	$\frac{1}{(\tau s + 1)^2}$	$\frac{1}{(\tau s + 1)^n}$
2.2. level controller, $k(s)$ from (17)	$1/\tau$	$\frac{1}{2\tau} \frac{1}{\tau s + 1}$	$\frac{s}{(\tau s + 1)^n - 1}$
2.3. $V(0)/q_{in}(0)$ from (18)	τ	2τ	$n\tau$
2.4. V_{tot}	$\tau \Delta q_{max}$	$2\tau \Delta q_{max}$	$n\tau \Delta q_{max}$

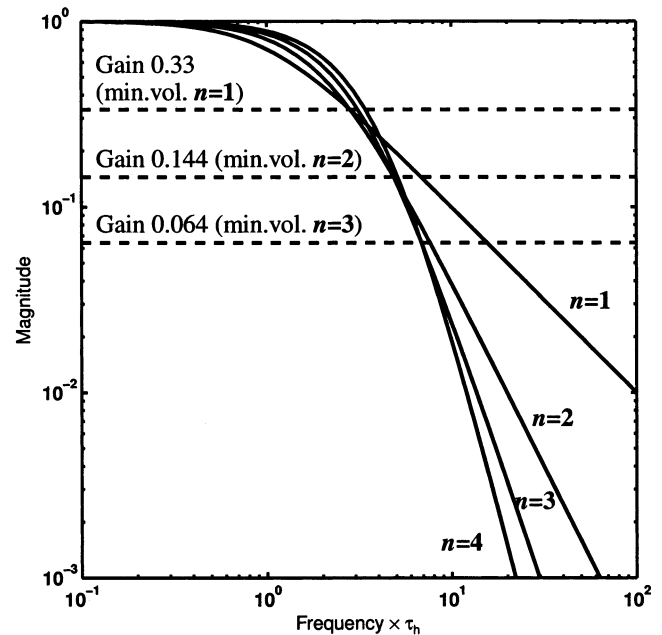

Figure 5. Frequency responses for $h(s) = 1/[(\tau_h/n)s + 1]^n$.

Note that $V(s)$ represents the deviation from the nominal volume. The maximum value of this transfer function occurs for all of our cases at low frequencies ($s = 0$).

In Table 1 we have found the level controller $k(s)$ and computed the required total volume for $h(s) = 1/(\tau s + 1)^n$.

For example, for a first-order filter, $h(s) = 1/(\tau s + 1)$, the required controller is a P controller with gain $1/\tau$ and the required volume of the tank is $V_{tot} = \tau \Delta q_{max}$.

Note that the resulting level controllers, $k(s)$, do not have integral action. A level controller without integral action was also recommended and further discussed by Buckley (ref 12, p 167) and Shinskey (ref 15, p 25).

For flow-rate disturbances, a high-order $h(s)$ can alternatively be realized using multiple tanks with a P level controller, $k(s)$, in each tank. However, the required total volume is the same as that found above with a single tank and a more complex $k(s)$, so the latter is most likely preferable from an economic point of view.

4. Step 1: Desired Buffer Transfer Function $h(s)$

What is a desirable transfer function, $h(s)$? We here present a frequency-domain approach for answering this question. Figure 5 shows the frequency plot of $h(s) = 1/[(\tau_h/n)s + 1]^n$ for $n = 1-4$, where τ_h in most cases is the total residence time in the tanks. With a given value of τ_h , we see that $n = 1$ is “best” if we want to reduce the effect of the disturbance at a given frequency by a

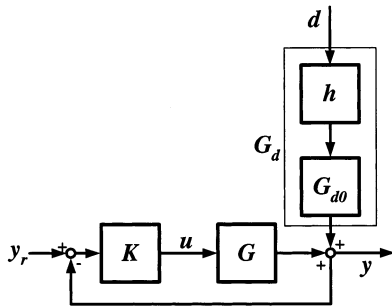

Figure 6. Feedback control system.

factor $f = 3$ ($=1/0.33$) or less; $n = 2$ is “best” if the factor is between 3 and about 7 ($=1/0.144$), and $n = 3$ is “best” if the factor is between about 7 and 15 ($=1/0.064$). Thus, we find that a larger order n is desired when we want a large disturbance reduction. We now derive more exactly the desired $h(s)$.

Let us start with an uncontrolled plant without a buffer tank. The effect of the disturbance d on the output y is then

$$y(s) = G(s) u(s) + G_{d_0}(s) d(s) \quad (19)$$

To counteract the effect of the disturbances, we apply feedback control ($u = -Ky$; see Figure 6). The resulting closed-loop response becomes

$$y(s) = S(s) G_{d_0}(s) d(s); \quad S = \frac{1}{1 + GK} \quad (20)$$

With integral action in the controller, the sensitivity function S approaches zero at low frequencies. However, at higher frequencies, the disturbance response, $|SG_{d_0}(j\omega)|$, may still be too large, and this is the reason for installing a buffer tank. The closed-loop response with a buffer tank is

$$y(s) = S(s) \underbrace{G_{d_0}(s) h(s)}_{G_d(s)} d(s) \quad (21)$$

which is acceptable if $|SG_{d_0}h|$ is sufficiently small at all frequencies. We need to quantify the term “sufficiently small”, and we define it as “smaller than 1”. More precisely, we assume that the variables and thus the model (G_{d_0}) has been scaled such that (i) the expected disturbance is less than 1 ($|d| \leq 1, \forall \omega$) and (ii) the allowed output variation is less than 1 ($|y| \leq 1, \forall \omega$).

From (21) we see that to keep $|y| \leq 1$ when $|d| = 1$ (worst-case disturbance), we must require

$$|S(j\omega) G_{d_0}(j\omega) h(j\omega)| \leq 1, \forall \omega \quad (22)$$

from which we can obtain the required $h(s)$. We illustrate the idea with an example.

Example 1 (continued) (Mixing Process). Let $y = c_0$, $d = c_{A,f}$, and $u = q_B$. Linearizing and scaling the model (3) then yields

$$G_{d_0}(s) = \frac{10}{s+1}; \quad S(s) = \frac{1}{1 + \frac{0.5}{s}e^{-s}}; \quad h(s) = \frac{1}{19s+1} \quad (23)$$

We here used for the scaling the following: expected variations in c_A , ± 20 mol/m³; range for q_B , ± 0.5 m³/min; allowed range for c , ± 1 mol/m³.

In Figure 7 we plot the disturbance effects $|G_{d_0}|$, $|SG_{d_0}|$, and $|SG_{d_0}h|$ as functions of frequency. Originally (without any buffer tank or control), we have $|G_{d_0}| = 10$ at lower frequencies. The introduction of feedback makes $|SG_{d_0}| < 1$ at low frequencies, whereas adding the buffer tank brings $|SG_{d_0}h| < 1$ also at intermediate frequencies.

In the following we will present methods for finding $h(s)$ based on the controllability requirement (22). There are two main cases:

S. Existing plant with an existing controller: The “counteracting” controller, $K(s)$, is already designed, so $S(s)$ is *known*. The “ideal” $h(s)$ is then simply the inverse of SG_{d_0} .

N. New plant: The “counteracting” controller, $K(s)$, is not known so $S(s)$ is *not known*. This is the typical situation during the design stage when most buffer tanks are designed.

In most cases we will choose $h(s)$ to be of the form $h(s) = 1/(\tau s + 1)^n$.

4.1. S Given (Existing Plant). We consider an existing plant where controller $K(s)$ is known. The task is to find $h(s)$ such that $|h(s)| < 1/|SG_{d_0}|, \forall \omega$. Several approaches may be suggested.

S1. Graphical Approach with $h(s) = 1/(\tau s + 1)^n$. This is done by selecting $h(s) = 1/(\tau s + 1)^n$ and adjusting τ until $|h(s)|$ touches $1/|SG_{d_0}|$ at one frequency. As a starting point, we choose the following:

(a) n is the slope of $|SG_{d_0}|$ in a log–log plot in the frequency area where $|SG_{d_0}| > 1$.

(b) τ is the inverse of the frequency where $|SG_{d_0}|$ crosses one from below.

S2. Numerical Approach with $h(s) = 1/(\tau s + 1)^n$. With a given n we find τ such that $|h|$ just touches $1/|SG_{d_0}|$ by solving the following problem:

$$\tau = \max_{\omega} \tau_{\text{req}}(\omega) \quad (24)$$

where

$$\tau_{\text{req}}(\omega) = \begin{cases} \frac{1}{\omega} \sqrt{|S(j\omega) G_{d_0}(j\omega)|^{2/n} - 1} & |S(j\omega) G_{d_0}(j\omega)| > 1 \\ 0 & \text{otherwise} \end{cases} \quad (25)$$

Because it is not practical to calculate $\tau_{\text{req}}(\omega)$ for all frequencies, we replace \max_{ω} with \max_{ω_i} , where $\omega_i \in \Omega$, which is a finite set of frequencies from the range of interest. The calculation is explicit and fast, so a large number of frequencies can be used. [This approach was used to obtain $h(s) = 1/(19s + 1)$ in Figure 7.]

As illustrated in example 2 (below), for $n > 1$ one may save some volume with the following approach, which is more involved because it includes nonconvex optimization.

S3. Numerical Approach with “Free” $h(s)$. We formulate a constrained optimization problem that minimizes the (total) volume of the buffer tank(s) subject to (22). As in the previous method, we formulate the optimization for a finite set of frequencies, Ω , from the frequency range of interest.

(I) Quality disturbances: For n mixing tanks

$$h(s) = \frac{1}{(\tau_1 s + 1) \dots (\tau_n s + 1)} \quad (26)$$

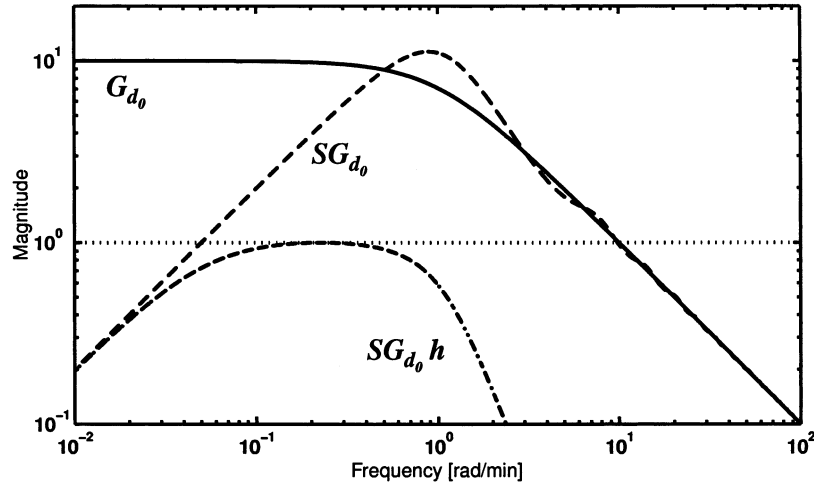

Figure 7. Original disturbance effect (G_{d_0}), with feedback control (SG_{d_0}) and with feedback control and a buffer tank ($SG_{d_0}h$). A buffer tank with a residence time of 19 min is required to bring $|S(j\omega) G_{d_0}(j\omega) h(j\omega)| < 1$ for all ω .

when the tanks are not necessarily equal. Because the flow rate is independent of the volumes ($\tau = V/q$), we may minimize the total residence time (instead of minimizing the total volume) subject to (22):

$$\min_{\tau_1, \dots, \tau_n} \tau_1 + \dots + \tau_n$$

subject to

$$|(\tau_1 j\omega_i + 1) \dots (\tau_n j\omega_i + 1)| \geq |S(j\omega_i) G_{d_0}(j\omega_i)|; \quad \omega_i \in \Omega \quad (27)$$

where Ω is a set of frequencies. This is a single-input, single-output variant of a method proposed in ref 20.

(II) Flow-rate disturbances:

$$h(s) = \frac{k(s, \mathbf{p})}{s + k(s, \mathbf{p})} \quad (28)$$

where we have parametrized the level controller with the parameter vector \mathbf{p} . We minimize subject to (22) the required tank volume (14):

$$\min_{\mathbf{p}} V = \min_{\mathbf{p}} \max_{\omega_i \in \Omega} \left| \frac{1}{j\omega_i + k(j\omega_i, \mathbf{p})} \right|$$

subject to

$$\left| S(j\omega_i) G_{d_0}(j\omega_i) \frac{k(j\omega_i, \mathbf{p})}{j\omega_i + k(j\omega_i, \mathbf{p})} \right| \leq 1; \quad \omega_i \in \Omega \quad (29)$$

Many controller formulations are possible, for example, the familiar PI(D) (D = derivative) controller or a state-space formulation. We here express the controller by a steady-state gain, k_s , n_z real zeros, and n_p real poles:

$$k(s, \mathbf{p}) = k_s \frac{(T_1 s + 1)(T_2 s + 1) \dots (T_{n_z} s + 1)}{(\tau_1 s + 1)(\tau_2 s + 1) \dots (\tau_{n_p} s + 1)} \quad (30)$$

and thus $\mathbf{p} = [k_s, T_1, \dots, T_{n_z}, \tau_1, \dots, \tau_{n_p}]$.

With $n_z = 0$ and $n_p = 1$ in (30), we get

$$h(s) = \frac{1}{\tau^2 s^2 + 2\tau\zeta s + 1} \quad (31)$$

$\zeta < 1$ does not give real time constants as the previous approaches. For a first-order filter [with $k(s) = k_s$ and

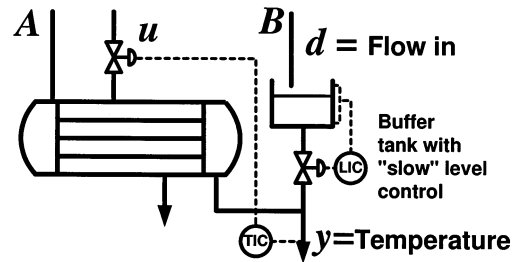

Figure 8. Temperature control with flow-rate disturbance.

$h(s) = 1/(\tau s + 1)$], there is no extra degree of freedom in the optimization, and we get the same result as that with (24).

Example 2 (Temperature Control with Flow-Rate Disturbance).

$$G_{d_0}(s) = 100; \quad G(s) = \frac{200}{100s + 1} e^{-s} \quad (32)$$

$$K_{TIC}(s) = 0.25 \frac{8s + 1}{8s} \quad (33)$$

This may represent the process in Figure 8, where two streams A and B are mixed, and we want to control the temperature (y) after the mixing point.

Stream A is heated in a heat exchanger, and the manipulated input, u , is the secondary flow rate in this exchanger. The disturbance, d , is variation from the nominal flow rate of B. d , u , and y are scaled as outlined above.

First consider the case without the buffer tank. Because $G_{d_0} = 100$, the disturbance has a large impact on the output, and a temperature controller is certainly required. However, this is not sufficient because, as seen in Figure 9, $|SG_{d_0}|$ exceeds 1 at higher frequencies and it approaches 100 at high frequencies.

We thus need to install a buffer tank with averaging level control to dampen the flow-rate disturbance at higher frequencies. The slope of $|SG_{d_0}|$ is 2 after it has crossed 1, so one would expect that a second order $h(s)$ is the best.

For the graphical approach S1, we use $h(s) = 1/(\tau s + 1)^2$. $|SG_{d_0}|$ crosses 1 at about frequency 0.024 rad/s, corresponding to $\tau \approx 1/0.024 = 42$, and because this is a flow-rate disturbance (II), we have from Table 1 that

Table 2. Buffer (Surge) Tank Design Procedure II (Flow-Rate Disturbance) Applied to the Temperature Control Example

step	design 1	design 2	design 3
1. numerical approach to obtain $h(s)$	S2: $h(s)$ first order	S2: $h(s)$ second order	S3(II): $h(s)$ second order
2.1. desired $h(s)$ (from step 1)	$\frac{1}{242s + 1}$	$\frac{1}{(36 + 1)^2}$	$\frac{1}{1548s^2 + 53.3s + 1}$
2.2. level controller, $k(s)$	0.0041	$\frac{0.014}{18s + 1}$	$\frac{0.019}{29s + 1}$
2.3. $V(0)/q_{in}(0)$	242	$2 \times 36 = 72$	56
2.4. V_{tot}	$242\Delta q_{max}$	$72\Delta q_{max}$	$56\Delta q_{max}$

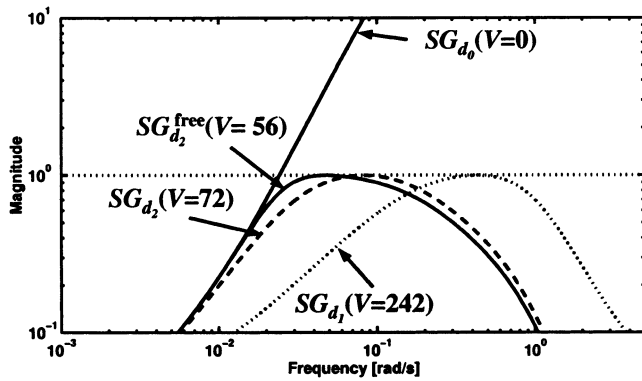
**Figure 9.** A buffer tank is needed for the temperature control problem: $|SG_{d_0}| > 0$ for frequencies above 0.024 rad/s. Comparison of $|SG_{d_i}| = |SG_{d_0}h|$ for designs 1–3 in Table 2.

$V_{tot} = 2\tau\Delta q_{max} \approx 84\Delta q_{max}$. The required level controller is $k(s) = 0.012/(21s + 1)$.

For the more exact numerical approaches (S2 and S3), we consider three designs, and the results are given in Table 2. Design 1 [with $h(s) = 1/(\tau s + 1)$] only requires a P level controller, but as expected, the required volume is large because $h(s)$ is first-order. Design 2 [with $h(s) = 1/(\tau s + 1)^2$] gives a considerably smaller required volume. From design 3 [with $h(s)$ in (31)], the required volume is even smaller than with design 2, as expected. Little is gained by increasing the order of $h(s)$ above 2.

In Figure 9 we plot the resulting $|SG_{d_i}|$ for the three designs, which confirms that they stay below 1 in magnitude at all frequencies. These results are further confirmed by the time responses to a unit step disturbance shown in Figure 10.

Buckley's method¹² gives a residence time of 10 min, which is much less than the minimum required residence time of about 56 min (see Table 2). The reason is that the disturbance needs to be reduced by a factor of 100, and not 10 as Buckley implicitly assumes.

4.2. S Not Given. The requirement is that (22) must be fulfilled; that is, the buffer tank with transfer function $h(s)$ must be designed such that $|SG_{d_0}h| \leq 1$ at all frequencies. However, at the design stage the controller and thus S is not known. Three approaches are suggested:

N1. Shortcut Approach. The requirement (22) must, in particular, be satisfied at the bandwidth frequency ω_B where $|S| = 1$, and this gives the (minimum) requirement

$$\underbrace{|G_{d_0}(j\omega_B)|}_f |h(j\omega_B)| \leq 1 \iff |h(j\omega_B)| \leq 1/f \quad (34)$$

In ref 21, pp 173–4, it is suggested that $\omega_B \leq 1/\theta_{eff}$, where θ_{eff} is the effective delay around the feedback loop. However, to get acceptable robustness, we here suggest to use a somewhat lower value

$$\omega_B \approx \frac{1}{2\theta_{eff}} \quad (35)$$

Skogestad²² proposes the following simple rule for estimating θ_{eff} :

$$\theta_{eff} = \theta + \tau_z + \frac{\tau_j}{2} + \sum_{i>j} \tau_i \quad \begin{cases} j = 2 \text{ for PI control} \\ j = 3 \text{ for PID control} \end{cases} \quad (36)$$

where θ is the delay, $\tau_z = 1/z$ is the inverse of a right half-plane zero z , and τ_i is the time lag (time constant) number i ordered by size so that τ_1 is the largest time constant.

We now assume $h(s) = 1/(\tau s + 1)^n$, use $\omega_B = 1/2\theta_{eff}$, and solve (34) to get

$$\tau \geq 2\theta_{eff} \sqrt{f^{2/n} - 1} \quad (37)$$

where $f \stackrel{\text{def}}{=} |G_{d_0}(j(1/2\theta_{eff}))|$. Alternatively, Figure 5 may be used for a given n to read off the normalized frequency $\nu = \omega\tau_h$ where $|h(j\nu)| = 1/f$, and the required τ for each tank is then $\tau = \nu n \omega_B$.

N2. Numerical Approach Based on Preliminary Controller Design. The above shortcut method only considers the frequency ω_B . To get a more exact design, we must consider all frequencies, and a preliminary controller design is needed. This approach consists of two steps:

N2a. Find a preliminary controller for the process, and from this, obtain $S(s)$.

N2b. Use one of the approaches S1, S2, or S3 from section 4.1.

For step N2a, we have used the method of Schei,²³ where we maximize the low-frequency controller gain $K_I = k_c/\tau_I$, subject to a robustness restriction (maximum value on the peak of S):

$$\min \tau_I/k_c$$

subject to

$$|S(j\omega)| < M_S; \quad \forall \omega \text{ and } S \text{ stable} \quad (38)$$

where for a PI controller $K(s) = k_c(\tau_I s + 1)/\tau_I s$. Compared to the optimization problem that Schei uses, we have added the constraint that S is stable. This is implemented by requiring the eigenvalues of \tilde{S} to be in the left half-plane, where \tilde{S} is obtained from S by replacing the delay with a Padé approximation. To obtain a robust design, M_S should be chosen low, typically 1.6–2. With this controller design, we then use one of the methods S1–S3 to design the buffer tank.

N3. Numerical Approach with a Simultaneous Controller and Buffer Tank Design. A more exact approach is to combine the controller tuning and the buffer tank design optimization into one problem. For (I) *quality disturbances*, the optimization problem may be formulated as an extension of (27):

$$\min_{\tau_1, \dots, \tau_n, \mathbf{p}_K} \tau_1 + \dots + \tau_n$$

subject to

$$|(\tau_1 j\omega_i + 1) \dots (\tau_n j\omega_i + 1)| \geq |S(j\omega_i, \mathbf{p}_K) G_{d_0}(j\omega_i)|; \quad \omega_i \in \Omega$$

$$|S(j\omega, \mathbf{p}_K)| < M_S; \quad \forall \omega$$

$$S(\mathbf{p}_K) \text{ is stable} \quad (39)$$

where \mathbf{p}_K is the controller parameter vector for $K(s)$. Likewise for (II) *flow-rate disturbances*, we get from (29)

$$\min_{\mathbf{p}, \mathbf{p}_K} V = \min_{\mathbf{p}, \mathbf{p}_K} \max_{\omega_i \in \Omega} \left| \frac{1}{j\omega_i + k(j\omega_i, \mathbf{p})} \right|$$

subject to

$$\left| S(j\omega_i, \mathbf{p}_K) G_{d_0}(j\omega_i) \frac{k(j\omega_i, \mathbf{p})}{j\omega_i + k(j\omega_i, \mathbf{p})} \right| \leq 1; \quad \omega_i \in \Omega$$

$$|S(j\omega, \mathbf{p}_K)| < M_S; \quad \forall \omega$$

$$S(\mathbf{p}_K) \text{ is stable} \quad (40)$$

where \mathbf{p} is the controller parameter vector for the level controller $k(s)$, which enters in $h(s)$, and \mathbf{p}_K is the controller parameter vector for the feedback controller $K(s)$, which enters in $S(s)$. To ensure effective integral action in K , these optimization problems must be extended by a constraint; for example, if $K(s)$ is a PI controller, a maximum value must be put on the integral time.

Example 2 (continued) (Temperature Control with Flow-Rate Disturbance (II)).

$$G_{d_0}(s) = 100; \quad G(s) = \frac{200}{100s + 1} e^{-s} \quad (41)$$

The available information of the process is given by (41), and we assume that the controller is not known. The delay is $\theta = 1$ s. We get the following results:

N1. The shortcut approach yields ($\omega_B = 0.5$ rad/s and $f = |G_{d_0}| = 100$ for all ω) from (37) (or Figure 5) the following:

(i) First-order filter ($n = 1$): $V_{\text{tot}} = 200\Delta q_{\text{max}}$.

(ii) Second-order filter ($n = 2$): $V_{\text{tot}} = 40\Delta q_{\text{max}}$.

N2. The Schei tuning in (38) followed by the optimal design (29) yields for a second order $h(s)$ ($n_Z = 0$ and $n_P = 1$) the following:

(i) $M_S = 1.6$: $V_{\text{tot}} = 52\Delta q_{\text{max}}$.

(ii) $M_S = 2$: $V_{\text{tot}} = 39\Delta q_{\text{max}}$.

N3. Simultaneous controller tuning and optimal design (40) yields with second-order $h(s)$ ($n_Z = 0$ and $n_P = 1$) the following:

(i) $M_S = 1.6$: $V_{\text{tot}} = 52\Delta q_{\text{max}}$ (as for method N2).

(ii) $M_S = 2$: $V_{\text{tot}} = 39\Delta q_{\text{max}}$ (as for method N2).

Note that $M_S = 1.6$ gives more robust (and "slow") controller tunings than $M_S = 2$ and therefore requires

a larger tank volume. The smallest achievable tank volume with a second-order filter is $V_{\text{tot}} = 27\Delta q_{\text{max}}$ (found with method N3 with M_S free). Methods N2 and N3 yield almost identical results for this example. The shortcut method N1 also gives a tank volume very similar to that found with $M_S = 2$.

5. Before or after?

If the buffer tank is placed upstream of the process, the disturbance itself is dampened before entering the process. If it is placed downstream of the process, the resulting variations in the product are dampened. The control properties are mainly determined by the effect of input u on output y (as given by the transfer function G). An upstream buffer tank has no effect on G , and also a downstream buffer tank has no effect on G provided we keep the original measurement. On the other hand, placement "inside" the process normally affects G . In the following we list some points that may be considered when choosing the placement. We assume that we prefer to have as few and small buffer tanks as possible (sometimes other issues come into consideration, like differences in cost due to different pressure or risk of corrosion, but this is not covered).

1. In a "splitting process", the feed flow is split into two or more flows (Figure 11a). One common example is a distillation column. To reduce the number of tanks, it will then be best to place the buffer tank at the feed (*upstream* placement). An exception is if only one of the product streams needs to be dampened, in which case a smaller product tank can be used because each of the product streams are smaller than the feed stream.

2. In a "mixing" process, two or more streams are mixed into one stream (Figure 11b). To reduce the number of tanks, it is here best with a *downstream* placement. An exception is if we only have disturbances in one of the feed streams because the feed streams are smaller than the product stream, leading to a smaller required size.

3. An advantage of a *downstream* placement is that a downstream buffer tank dampens *all* disturbances, including disturbances in the control inputs. This is not the case with upstream tanks, which only dampen disturbances entering upstream of the tank.

4. An advantage of an *upstream* placement is that the process stays closer to its nominal operation point and thus simplifies controller tuning and makes the response more linear and predictable (see example 3).

5. An advantage of the "*inside*" placement is that it may be possible to avoid installation of a new tank by making use of an already planned or existing unit, for example, by increasing the size of a chemical reactor.

6. A disadvantage with placing the buffer tank inside or downstream of the process is that the buffer tank then may be within the control loop, and the control performance will generally be poorer. Also, its size will effect the tuning, and the simultaneous approach (N3) is recommended. For the downstream placement, these problems may be avoided if we keep the measurement before the buffer tank, but then we may need an extra measurement in the buffer tank to get a more representative value for the final product.

Example 3 (Distillation Column). We apply the methods from section 4.1 to a distillation column and compare the use of a single feed tank with the use of two product tanks (Figure 12). We consider a distillation

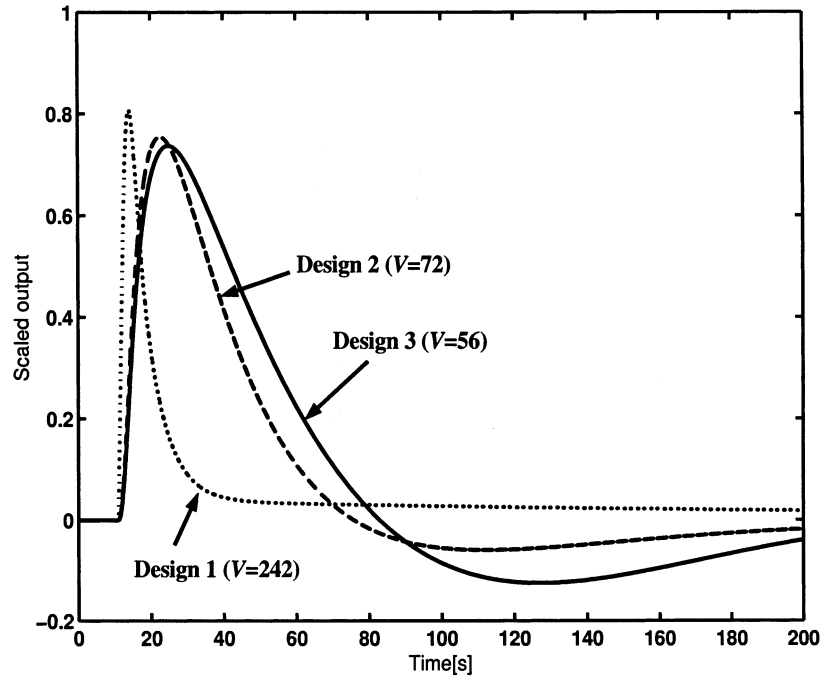

Figure 10. Temperature control with flow-rate disturbance: Response in the scaled output to a unit step in the disturbance (flow rate) with different tank sizes and level controllers (Table 2).

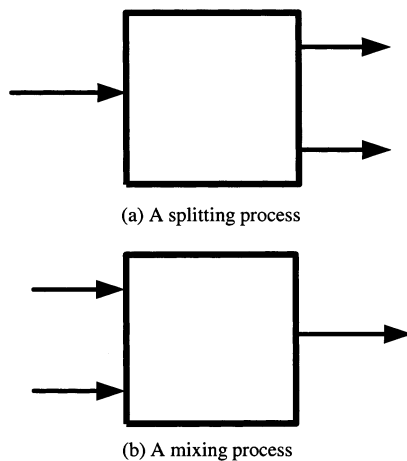

Figure 11. Two types of processes.

column with 40 stages (the linearized model has 82 states; see column A from ref 21, p 425). The disturbances to the column are feed flow rate and composition ($d_1 = F$ and $d_2 = z_F$), and the outputs are the mole fractions of the component in top and bottom products, respectively (y_1 and y_2). The manipulated variables are the reflux and the boilup ($u_1 = L$ and $u_2 = V$). The variables have been scaled so that a variation of $\pm 30\%$ in the feed flow rate corresponds to $d_1 = \pm 1$ and a variation of $\pm 10\%$ in the feed composition corresponds to $d_2 = \pm 1$. A change in the top and bottom product composition of ± 0.01 mole fraction units corresponds to a change of ± 1 in y_1 and y_2 . Decentralized PI controllers are used to control the compositions. In the top, $K_1(s) = 6.84(20s + 1)/20s$, and in the bottom, $K_2(s) = 5.46(20s + 1)/20s$. There is a delay of 10 min in each loop, which we represent with fifth-order Padé approximations in the linear model. Nominally, the feed flow rate is $1 \text{ m}^3/\text{min}$, and the top and bottom concentrations are 0.99 and 0.01, respectively. The holdup in the reflux and the boiler are controlled with P controllers (with gain 10) by the top and bottom product streams, respectively.

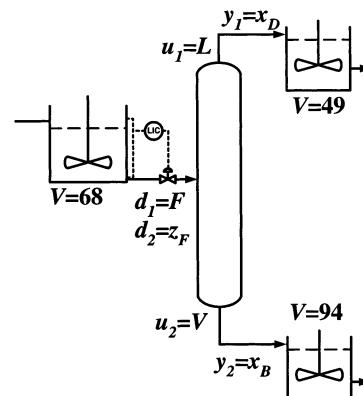

Figure 12. Distillation column with either one feed surge tank or two product mixing tanks to dampen disturbances.

We consider the effect of the flow-rate disturbance, d_1 . The closed-loop gains from d_1 to y_1 and y_2 without any buffer tank, $|SG_{d_{10}}|$ and $|SG_{d_{20}}|$ are shown with solid lines in Figure 13. The gains are both above 1 at intermediate frequencies, so our purity requirements will not be fulfilled, unless we install a buffer tank.

Upstream Placement (Feed Surge Tank). S is known, and with $n = 1$, (24) in method S2 yields $\tau = 114 \text{ min}$. The resulting $|SG_{d_1}|$ and $|SG_{d_2}|$ are shown with dashed lines, and we see that $|SG_{d_2}|$ just hits 1 (as expected). $1/|h|$ is also plotted (dash-dotted) to indicate the limiting frequency, which is not at the maximum of $|SG_{d_{20}}|$ but at a lower frequency "shoulder". Following design procedure II, we now get the following:

- 2.1. $h(s) = 1/(114s + 1)$.
- 2.2. The required level controller for the buffer tank is $k(s) = 1/114 = 0.0088$.
- 2.3. $V(0)/q_{in}(0) = \tau = 114$.
- 2.4. $V_{tot} = \tau \Delta q_{max} = 114 \text{ min} \times 2 \times 0.3 \text{ m}^3/\text{min} = 68 \text{ m}^3$.

Comment: Because the slope of $|SG_{d_{20}}|$ is less than 1 around the limiting frequency, higher order filters will increase the volume demand. For example, with $n = 2$,

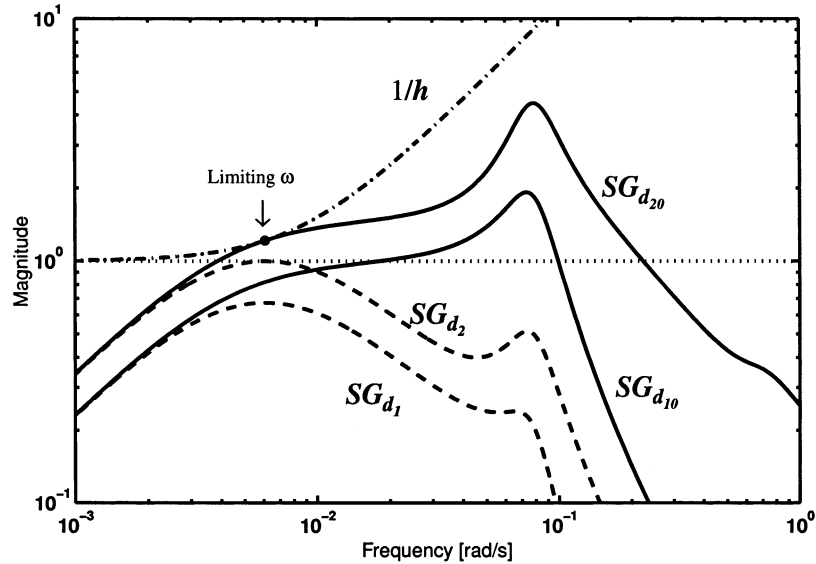
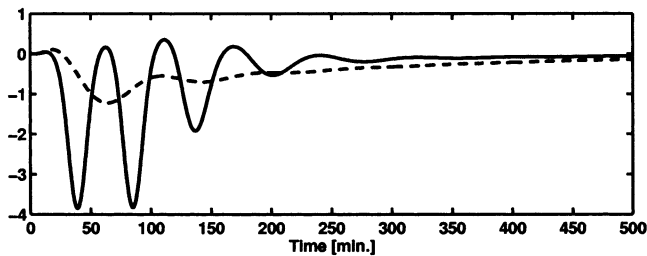
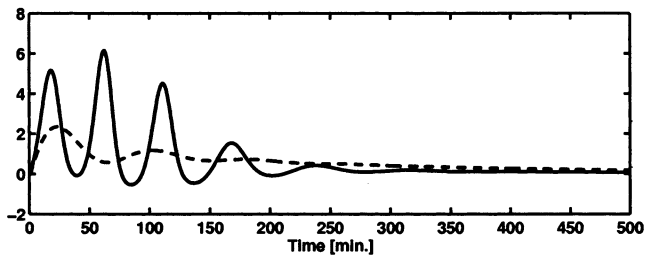

Figure 13. Feed flow disturbance for the distillation column: $|SG_{d_{10}}|$ and $|SG_{d_{20}}|$ (for top and bottom) are both above 1 (solid line). A feed tank with averaging level control, $h(s) = 1/(114s + 1)$, brings the disturbance gain to both top and bottom below 1 (dashed). Note that $1/h(s)$ is just touching $|SG_{d_{20}}|$.



(a) Output y_1 . Nonlinear simulation (solid) and linear simulation (dashed).



(b) Output y_2 . Nonlinear simulation (solid) and linear simulation (dashed).

Figure 14. Distillation example with no buffer tanks installed. The control system is not able to handle the disturbance. There is a large deviation between nonlinear and linear simulation.

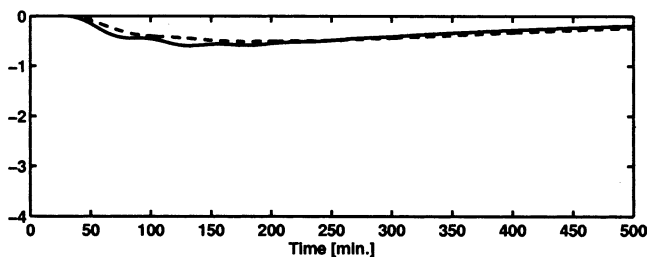

(a) Output y_1 . Nonlinear simulation (solid) and linear simulation (dashed).

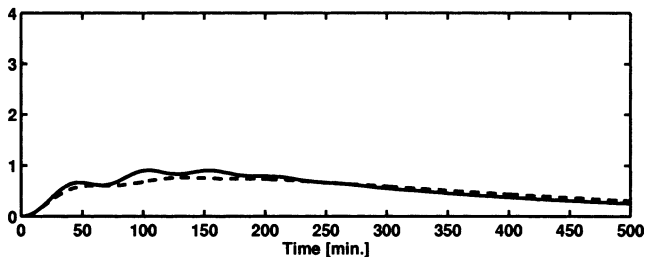

(b) Output y_2 . Nonlinear simulation (solid) and linear simulation (dashed).

Figure 15. Distillation example with a feed tank of 68 m³. Both outputs stay within ± 1 , and the nonlinear simulation is close to the linear one.

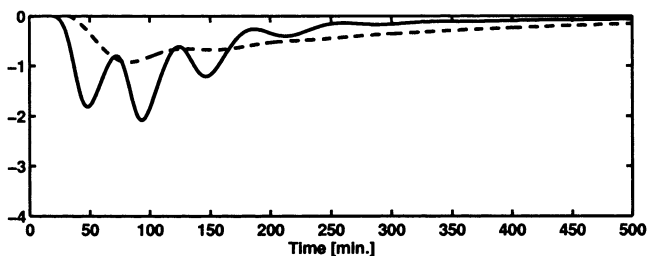

(a) Output y_1 . Nonlinear simulation (solid) and linear simulation (dashed).

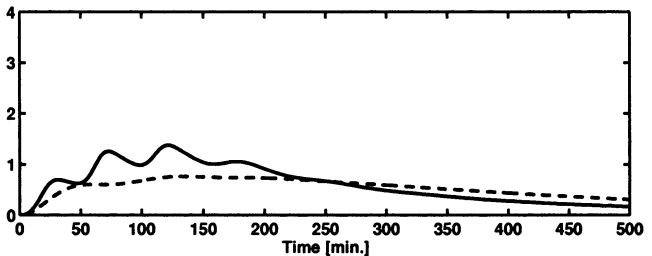

(b) Output y_2 . Nonlinear simulation (solid) and linear simulation (dashed).

Figure 16. Distillation example with product tanks at the top (11.5 m³) and at the bottom (57 m³). The outputs deviate from ± 1 in the nonlinear simulations.

(24) gives $\tau = 76.6$ min, and $V_{\text{tot}} = 2\tau\Delta q_{\text{max}} = 91.9$ m³.

Downstream Placement (Product Mixing Tank). Because both $|SG_{d_{10}}| > 1$ and $|SG_{d_{20}}| > 1$ at some frequencies, we must apply one mixing tank for each of the two products. When we designed the feed tank, we had to consider the worst of $|SG_{d_{10}}|$ and $|SG_{d_{20}}|$, but now we may consider $|SG_{d_{10}}|$ for the top product and $|SG_{d_{20}}|$ for the bottom product. With $n = 1$, (24) yields 23 min for the top buffer tank and as before 114 min for the bottom tank. The corresponding volumes are $23 \times 0.5 = 11.5$ m³ (top) and $114 \times 0.5 = 57$ m³ (bottom), which gives a total volume of 69 m³, which is the same as that for the feed tank. However, the feed tank placement is preferred because we then need only one tank.

Nonlinear Simulations. The above design is based on a linearized model, and (as expected) the feed tank placement is further justified if we consider a nonlinear model because the column is then less perturbed from its nominal state. This is illustrated by the simulations in Figures 14–16. If the buffer tanks are placed downstream, the nonlinear response deviates considerably from the linear response, and the tanks designed by linear analysis are too small. By trial and error with disturbance step simulations on the nonlinear model, we find that $\tau_t = 98$ min and $\tau_b = 188$ min are needed for the top and bottom product tanks. This gives a total volume of 143 m³, considerably larger than the required feed tank of 68 m³.

In conclusion, an upstream feed tank with a P controller (averaging level control) proves best for this example. The example also illustrates that for nonlinear processes the buffer tank design methods that we have proposed are most reliable for the design of upstream buffer tanks. For (highly) nonlinear processes, the results should, if possible, be checked with simulations on a nonlinear model.

6. Conclusions

The controlled variables (y) must be kept within certain limits despite disturbances (d) entering the process. High-frequency components of disturbances are dampened by the process itself, while low-frequency components, e.g., the long-term effect of a step, are handled by the control system. There are, however, always limitations in how quickly a control system can react, for example, as a result of delays. Thus, for some processes there is a frequency range where the original process and the controller do not dampen the disturbance sufficiently. In this paper we introduce methods for designing buffer tanks based on this insight. The methods consist of two steps:

Step 1. Find the required transfer function $h(j\omega)$ such that $|S(j\omega) G_c(j\omega) h(j\omega)| < 1$, $\forall \omega$ (with scaled variables). The methods for this have been divided into two groups depending on whether the control system for the process is already designed (methods S1–S3) or not (methods N1–N3). The shortcut methods (S1/S2 or N1), supplemented with nonlinear simulations, are recommended for most practical designs.

Step 2. Design a buffer tank that realizes this transfer function $h(s)$. For a first-order transfer function, $h(s) = 1/(\tau s + 1)$, we have the following:

I. Quality Disturbances. Install a mixing tank with volume $V = q\tau$, where q is the nominal flow rate.

II. Flow-rate Disturbances. Install a tank with averaging level control with gain $k(s) = 1/\tau$ and volume $V = \tau\Delta q_{\text{max}}$, where Δq_{max} is the expected range (from minimum to maximum) in the flow-rate variation.

Sometimes a higher-order $h(s)$ is preferable, in which case we need (I) for quality disturbances more than one mixing tanks and (II) for flow-rate disturbances a more complicated level controller $k(s)$ (with lags) (see Table 1).

Literature Cited

- (1) Lieberman, N. P. *Process Design for Reliable Operations*; Gulf Publishing Co.: Houston, TX, 1983.
- (2) Sandler, H. J.; Luckiewicz, E. T. *Practical Process Engineering*; McGraw-Hill Book Co.: New York, 1987.
- (3) Ulrich, G. D. *A Guide to Chemical Engineering Process Design and Economics*; John Wiley & Sons: New York, 1984.
- (4) Walas, S. M. Rules of thumb, selecting and designing equipment. *Chem. Eng.* **1987**, *94* (4), 75–81.
- (5) Wells, G. L. *The Art of Chemical Process Design*; Elsevier: Amsterdam, The Netherlands, 1986.
- (6) Sigales, B. How to design reflux drums. *Chem. Eng.* **1975**, *82* (5), 157–160.
- (7) Watkins, R. N. Sizing separators and accumulators. *Hydrocarbon Process.* **1967**, *46* (11), 253–256.
- (8) Ludwig, E. E. *Applied Process Design for Chemical and Petrochemical Plants*; Gulf Publishing Co.: Houston, TX, 1977; Vol. 1.
- (9) Harriott, P. *Process Control*; McGraw-Hill: New York, 1964.
- (10) Hiester, A.; Melsheimer, S.; Vogel, E. Optimum size and location of surge capacity in continuous chemical processes. AIChE Annual Meeting, Nov 15–20, 1987; Paper 86c.
- (11) Marlin, T. E. *Process Control. Designing Processes and Control Systems for Dynamic Performance*; McGraw-Hill: New York, 1995.
- (12) Buckley, P. S. *Techniques of Process Control*; John Wiley & Sons, Inc.: New York, 1964.
- (13) McDonald, K. A.; McAvoy, T. J.; Tits, A. Optimal averaging level control. *AIChE J.* **1986**, *32* (1), 75–86.
- (14) Shunta, J. P.; Fehervari, W. Nonlinear control of liquid level. *Instrum. Technol.* **1976**, Jan, 43–48.
- (15) Shinskey, F. G. *Process Control Systems—Application, Design, and Tuning*, 4th ed.; McGraw-Hill Inc.: New York, 1996.
- (16) Shinskey, F. G. *pH and pI on Control in Process and Waste Streams*; John Wiley & Sons: New York, 1973.
- (17) McMillan, G. K. *pH Control*; Instrument Society of America: Research Triangle Park, NC, 1984.
- (18) Walsh, S. Integrated Design of Chemical Waste water Treatment Systems. Ph.D. Thesis, Imperial College, London, U.K., 1993.
- (19) Faanes, A.; Skogestad, S. pH-neutralization: Integrated process and control design. *Comput. Chem. Eng.* **2002**, submitted for publication.
- (20) Zheng, A.; Mahajanam, R. V. A quantitative controllability index. *Ind. Eng. Chem. Res.* **1999**, *38*, 999–1006.
- (21) Skogestad, S.; Postlethwaite, I. *Multivariable Feedback Control*; John Wiley & Sons: New York, 1996.
- (22) Skogestad, S. Simple analytic rules for model reduction and PID controller tuning. *J. Process Control* **2003**, *13* (4), 291–309.
- (23) Schei, T. S. Automatic tuning of PID controllers based on transfer function estimation. *Automatica* **1994**, *30* (12), 1983–1989.

Received for review July 15, 2002

Revised manuscript received February 5, 2003

Accepted February 19, 2003

IE020525V