

Dynamics and Control of Integrated Three-Product (Petlyuk) Distillation Columns

Erik A. Wolff, Sigurd Skogestad*and Kjetil Havre
University of Trondheim
N-7034 Trondheim-NTH, NORWAY

AIChE Annual Meeting, St. Louis, Nov. 1993, Paper 195a

Abstract

The separation of more than two components has traditionally been done by arranging distillation columns in series. Several alternative configurations exist, most notably the direct and indirect sequence (where light or heavy components are removed first, respectively).

In 1962 Cahn and Di Micelli proposed a promising alternative design for separating a ternary feed. This design consists of a prefractionator whose product is fed to a 2-feed, 3-product column, giving a setup with only one reboiler and one condenser. It is usually denoted the Petlyuk column after a Petlyuk who studied the system theoretically in 1965. Many authors have later predicted considerable savings in energy and capital cost with this design, but still few of these integrated columns have been built. One reason is probably that the Petlyuk column, compared to an ordinary distillation column, has many more degrees of freedom in both operation and design. This undoubtably makes the design of both the column and its control system more complex.

In this work we study the dynamics and controllability of the Petlyuk design and clarify some of the operational and functional properties. We also propose control schemes for controlling three and four product compositions. The results indicate that there may be serious problems involved in operating the Petlyuk column, at least for high-purity separations.

*Address correspondence to this author. Fax: +47-7359-4080, E-mail: skoge@kjemi.unit.no

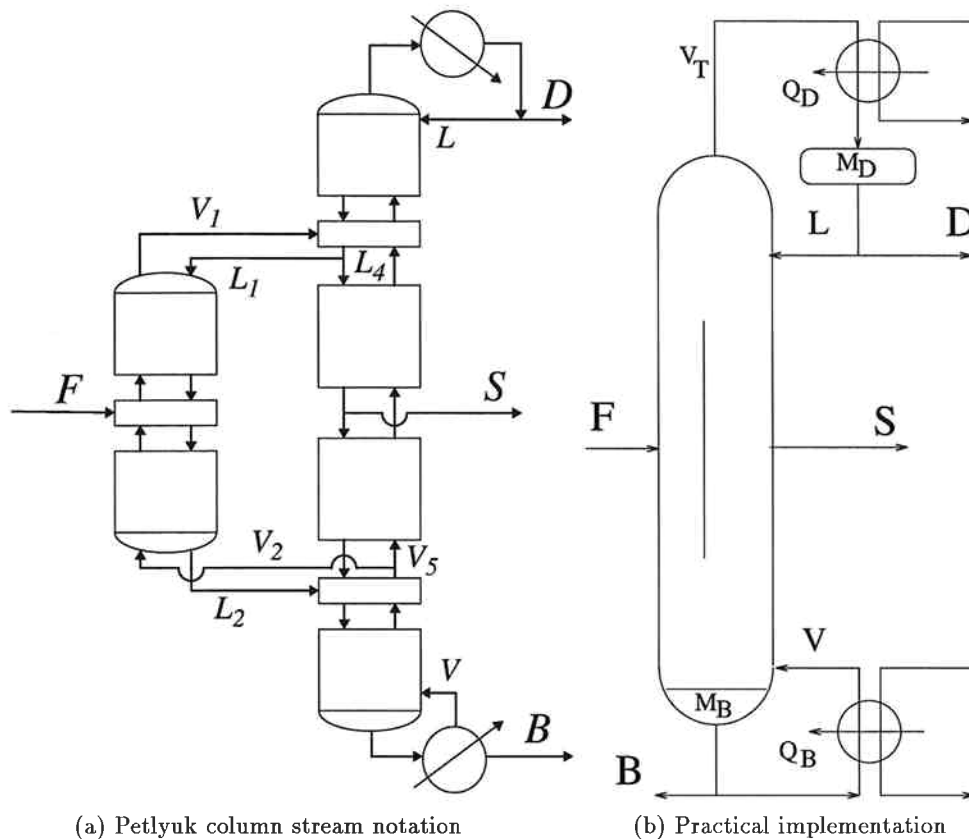

Figure 1: Petlyuk distillation.

1 Introduction

The studied complex column (Fig. 1a) is called a Petlyuk column, after Petlyuk et al. (1965), although Cahn and Di Micelli first described this configuration in 1962. A similar design, both a condenser and reboiler also for the prefractionator (which we will denote a pseudo-Petlyuk design) was proposed even 20 years earlier by Brugma (1939).

The Petlyuk design consists of a prefractionator with reflux and boilup from the downstream column, whose product is fed to a 2-feed, 3-product column, giving a setup with only one reboiler and one condenser. Petlyuk's main reason for this design was to avoid thermodynamic losses from mixing different streams at the feed tray location. We will hereafter denote the product streams D , S and B (and feed F), with ternary components **1**, **2** and **3**. Molefractions are denoted x_{ij} where i is the stream and j is the component.

The practical implementation of such a column can be accomplished in a single shell by inserting a vertical wall through the middle section of the column (figure 1b). As compared to the direct or indirect sequence, this implementation of the Petlyuk design offers savings in investment (only one shell and two exchangers) as well as operating costs. Although several authors have studied the design of such columns, very little work has been done of the operation and control.

Tedder and Rudd (1978) were among the first to study the optimal separation of a given ternary feed. The alternatives included the direct and indirect sequence, columns with sidedraws, columns with sidestrippers and siderectifiers and a pseudo-Petlyuk design. They found the pseudo-Petlyuk design to be preferable when the fraction of intermediate component **2** in the feed is large (40% - 80%).

Cerda and Westerberg (1981) derived simple methods for estimating the operating parameters at limiting flow conditions.

Fidowski and Krolikowski (1986) compared the optimal (minimum) vapor flow rates for the direct and indirect sequence with both the Petlyuk and the pseudo-Petlyuk design. The Petlyuk design shows significant savings. The developed analytical expressions are based on the Underwood

formulas.

Glinos and Malone (1988) also derived analytical expression for various alternative designs, including the Petlyuk design. Their recommendations are to use the Petlyuk design when the fraction of intermediate component **2** in the feed is small, and they found that the maximum vapor savings compared to simple sequences were about 50% when $x_{F2} \rightarrow 0$. They found that columns with siderectifiers may be equally well suited when less the fraction of component **2** in the feed is less than 30%. However, they concluded that Petlyuk columns may also have a significant advantage for moderate or high x_{F2} values, but that the conclusion depends on the relative volatilities.

Chavez et al. (1986) discuss the possibility for multiple steady states in complex columns, concentrating their work on a Petlyuk design. They found that the Petlyuk design has five degrees of freedom at steady-state, and they found that four different steady-state solutions may occur when specifying three purities (in each of the products) plus bottom rate and reboiler duty. They explain this in terms of matching specifications in interlinked columns.

Faravelli et al. (1989) build on the work of Chavez et al. and look at which of the steady states are most resilient to changing internal flows. They applied "control" to the column, but only to aid in finding the steady-state solutions.

Triantafyllou and Smith (1992) present a good overview over the design of Perlyuk columns, and explain how it may be approximated as a regular column with two sidestrippers which are joined together.

The only report of an industrial implementation of a Petlyuk design is from BASF in Germany (as reported by Rudd, 1992)

In this work we will study the dynamic behavior of a Petlyuk column and propose suitable controller structures.

2 Degrees of Freedom

We here consider the operating variables in a given column with fixed stages, feed locations, etc. In any scheme the number of control objectives must be less or equal than the number of independent (manipulated) variables. This number describes the *Degrees of Freedom* of the system, here abbreviated to DOF.

The DOF's for control of binary distillation and the Petlyuk column are shown in figure 2. We now want to consider the DOFs at steady-state. Starting with binary distillation and assuming that the holdups (condenser level, reboiler level and pressure) are already controlled, two independent (manipulated) variables remain, for example L and V , which may be used to satisfy (control) two specifications (outputs), for example top and bottom composition, y_D and x_B .

In a Petlyuk column we get three additional degrees of freedom - one for each of the three additional streams leaving the column. These are the sidestream S plus the fractions of liquid and vapor ($R_L = L_1/L$ and $R_V = V_2/V$) send back to the prefractionator. Note that in this analysis the prefractionator itself does not have any degrees of freedom at steady state. The five DOF's for the Petlyuk design may be used to specify (control) the top and bottom composition (x_{D1} and x_{B3}) and one or two compositions in the side stream (e.g., x_{S2} or x_{S3} and x_{S1}). This leaves one or two degrees of freedom left for optimization purposes, which we in this paper select to be minimizing the energy consumption in terms of the heat duty Q_B (It may have been used to optimize also the size of the column, e.g., the number of stages, but this is not considered here).

There are also possibilities for increasing the DOFs, for example, by taking of several side streams (e.g., a vapor and liquid side stream, S_V and S_L), and by using a triple-wall solution as suggested in the figure in the paper of Petlyuk et al., but these are not considered here.

In a usual two-product distillation column one can at most control one specification for each product (two-point control). Simpler alternatives are no control (relying on self-regulation) or one-point control. Since in high purity distillation columns it is critical that the overall product split is adjusted correctly (such that $D/F = 1 - B/F$ is approximately equal to the fraction of light component), one generally finds that no control is unacceptable. However, due to strong interactions one-point control, with the composition in the other end being self-regulated, is usually satisfactory if some over-refluxing (increased energy consumption) is allowed for.

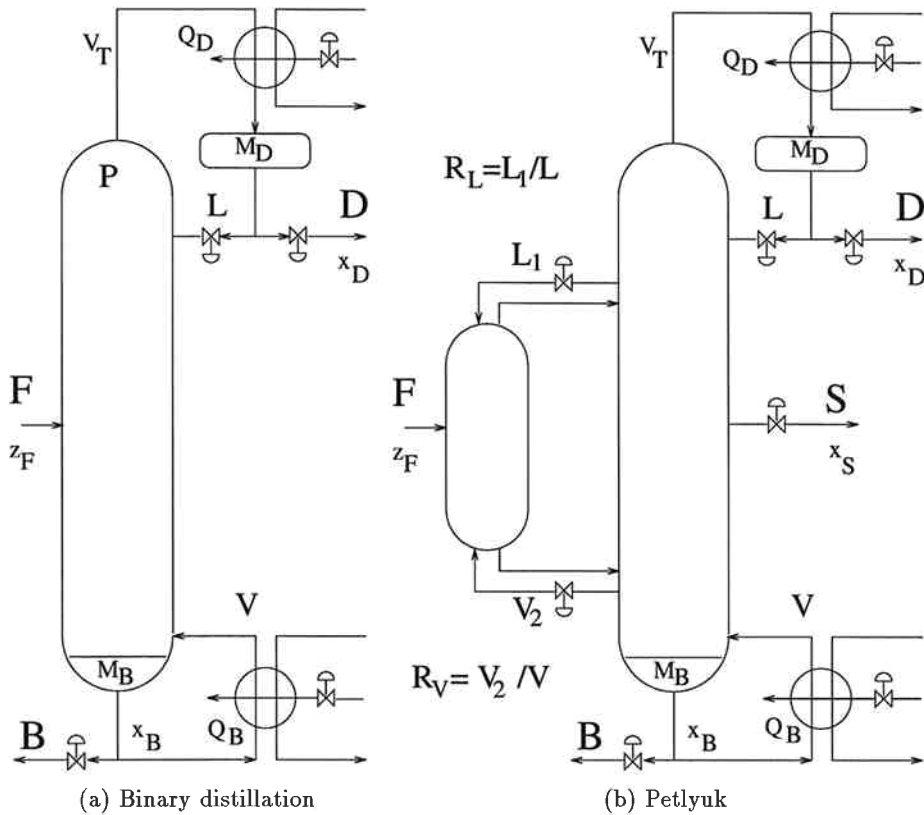

Figure 2: DOF's in distillation.

For a Petlyuk scheme one must at least adjust two product splits correctly (e.g. D/F to match the light component and S/F to match the intermediate component), thus at least two-point control is required. We have not studied such a control scheme here, but again it is clear that it will at least require increased energy consumption. Additionally, there will be no way to adjust the separation in the prefractionator, as determined by the recycle fractions R_L and R_V .

In this paper we first study three-point control where one composition in each product is controlled. At first sight it may seem like such a control scheme may perform well if we only are interested in controlling one composition in the side stream, for example, the fraction of component 2, x_{S2} . However, with only one degree of freedom we will not be able to adjust the ratio between the sidestream impurities, x_{S1} and x_{S3} ¹. This may in itself not be a problem, but we will show later that it is, since we find that the amount of side stream S , primarily affects the heavy impurity, x_{S3} , and has little effect on the light impurity, x_{S1} . It is then impossible to control the sidestream purity if for some reason x_{S1} is too high.

Finally we consider four-point control with four product composition specifications (two in the sidestream).

¹This result also follows from a simple analysis of the material balance. Consider the case where we want to control the purities in the top and bottom products, while we fix the sidestream S . In the forthcoming discussion we will assume that the extreme components do not appear in the opposite product streams, i.e. no component 1 in the bottoms etc..

We specify x_{D1} , x_{B3} and S and set up the total component balance over the column:

$$\begin{aligned}
 Dx_{D1} + Sx_{S1} &= Fx_{F1} \\
 Dx_{D2} + Sx_{S2} + Bx_{B2} &= Fx_{F2} \\
 Sx_{S3} + Bx_{B3} &= Fx_{F3}
 \end{aligned}
 \tag{1}$$

Furthermore $x_{D2} = 1 - x_{D1}$ and $x_{B2} = 1 - x_{B3}$ since we assumed no extreme components in D and B .

This set of three equations has four unknown independent variables; D , B and two of x_{S1} , x_{S2} and x_{S3} . Thus, for a fixed flowrate S the component distribution in the sidestream may vary.

3 Analysis tools

In the following we will use a plant description of the form

$$y(s) = G(s)u(s) + G_d(s)d(s) \quad (2)$$

where G and G_d denote the process and disturbance plant model and y , u and d are the measurements, manipulated inputs and disturbances, respectively.

In this paper we mainly use the relative gain array (RGA or Λ) to look at interaction in the distillation column. The properties of the RGA are well known (e.g., Grosdidier et al., 1985). The most important for our purpose are: 1) No twoway interaction is present when $\Lambda = I$, 2) The RGA is independent of scaling in inputs or outputs, and 3) The rows and columns both sum up to 1. To evaluate the disturbance sensitivity, we consider the closed loop disturbance gain (CLDG) which is the appropriate measure when we use decentralized control (Hovd and Skogestad, 1992). The CLDG is defined as $G_{diag}G^{-1}G_d$, where G_{diag} consists of the diagonal elements of G .

We also look at the singular value decomposition $G = U\Sigma V^T$ and examine the elements of G , G_d and $G^{-1}G_d$.

In general, high purity distillation is usually an ill-conditioned process, meaning that the column is much more sensitive in one direction of manipulation than another (easier to “move” the composition profile up or down than increasing or decreasing *both* purities). It is therefore of interest to establish how the interaction is changed by controlling another composition in the column.

4 Case study

Previous authors have looked at a variety of ternary component systems, from close boiling C_4 isomers to component sets spanning C_1 to C_6 . We have chosen the system ethanol, propanol and butanol for the examples. This system has a relative volatility of approximately 4:2:1 for the three components.

Steady state simulations were done with ASPENPLUS, using equation of state (Redlich-Kwong-UNIFAC) based thermodynamic properties. Optimization, linearization and dynamic simulations were performed with SPEEDUP, assuming constant molar flows and constant relative volatility. This model incorporates linearized flow dynamics with a time constant of 3.6 minutes.

We have used the same number of trays in the center sections of the “main” column as in the prefractionator. This is in line with the assumed industrial implementation with a dividing wall in the shell.

The “main” column consists of 40 stages and there are 18 stages in the prefractionator. The feed is liquid with a flowrate of 60 *kmol/min.* and feed composition $x_F = [0.33, 0.33, 0.33]$. We demand 99% pure products in the top and bottom and the design purity in the sidestream is 99%.

The disturbances considered are changes in the feed flow and feed composition. Simulations are performed with the following perturbation sequence:

1. Feed flow increase (60 \rightarrow 50 *kmol/min.*).
2. Feed composition change ($x_{Fi} = [0.33, 0.33, 0.33] \rightarrow x_{Fi} = [0.33, 0.40, 0.27]$).
3. Distillate setpoint increase ($x_{D1} = 0.99 \rightarrow x_{D1} = 0.995$).

4.1 Steady state considerations

How resilient is the column to variations in R_L and R_V ? Consider a column in which four specifications are controlled; the purity of the top and bottom products as well as two molefractions in the sidestream. One DOF remains for optimizations properties. The energy use (represented by the boilup Q_B) is plotted against the free variable R_V and R_L , respectively, in figure 3. We see that there exists an optimal operating point (choice of R_V) with an additional local minima. The choice of sub-optimal boilup (or reflux) give multiple solutions for the split ratios R_L and R_V similar to that noted by Chavez (1986).

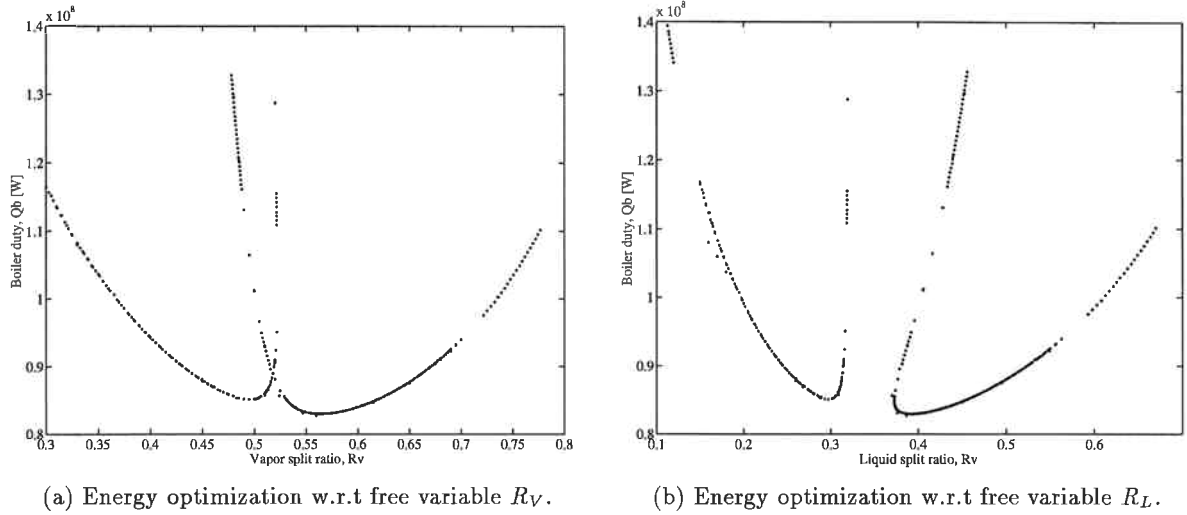

Figure 3:

Variable	x_{S2}			
	0.99	0.98	0.97	0.96
Boilup V/F	2.185	1.832	1.688	1.605
Reflux L/F	1.852	1.498	1.355	1.273
Liquid split ratio R_L	0.394	0.373	0.357	0.344
Vapor split ratio R_V	0.550	0.560	0.569	0.570

Table 1: Optimal design variables for varying x_{S2} spec.

We see that there exist choices for R_L that give *no* solution. This represents potential problems as will be discussed later on.

The odd behavior is reduced when the (same) column is operated at lower product purities ($x_{D1} = x_{S2} = x_{B3} = 0.98$). In this case $Q_B = f(R_L)$ describes a nice convex curve, while $Q_B = f(R_V)$ does not. It is evident that some of the operational problems will be linked with high purity operation.

Economic impact of sidestream purity. The effect of the sidestream purity specification on the boilup was also investigated. We considered designs with 3 specified product compositions ($x_{D1} = 0.99$, $x_{B3} = 0.99$ and x_{S2} specified between 0.99 and 0.96) R_L and R_V were adjusted to minimize the boilup rate V/F , which with our assumption of constant heat of vaporization is proportional to the heat input Q_B . The resulting designs are given in table 1. We see that the specification on x_{s2} has a large influence on the boilup rate and thus on the operating costs. The optimal recycle ratios R_L and R_V also change. It will be of interest to see how the split ratios influence the behavior of the column.

4.2 Three-point control, LVS-configuration

We will look at several control strategies for controlling the sidestream purity; applying S , R_L and R_V as possible manipulated variables. First we look at using the sidestream flowrate for controlling x_{S2} . The set of measurements, manipulated variables and disturbances is then

$$y = \begin{pmatrix} x_{D1} \\ x_{B3} \\ x_{S2} \end{pmatrix} \quad u = \begin{pmatrix} L \\ V \\ S \end{pmatrix} \quad d = \begin{pmatrix} F \\ x_{F1} \\ x_{F2} \end{pmatrix}$$

The Petlyuk column has no poles or transmission zeros in the right half plane (RHP). Thus, there are no fundamental problems with instability, inverse responses or inherent bandwidth limitations.

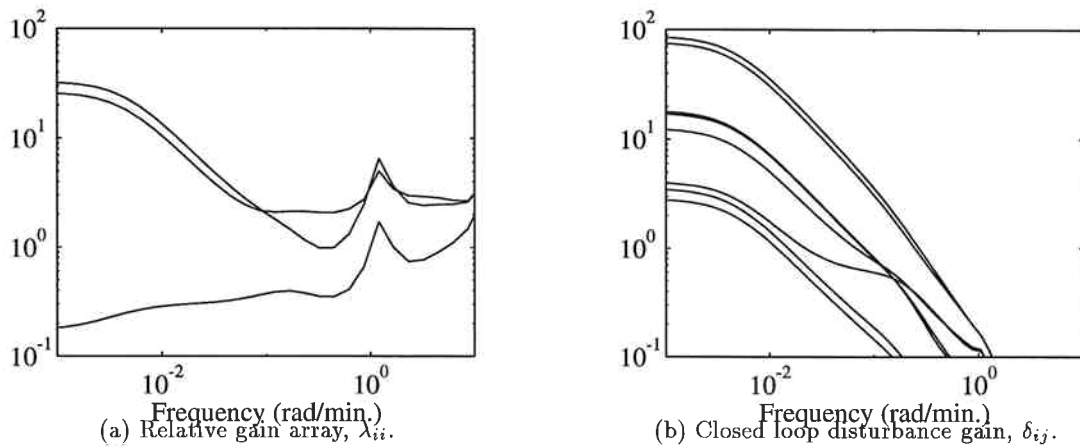

Figure 4: Analysis results for three point control

The steady state gain matrix G is

$$G(0) = \begin{pmatrix} 112.9 & -112.6 & 0.112 \\ -85.3 & 86.6 & 14.5 \\ 28.4 & -26.8 & -9.70 \end{pmatrix}$$

We see that the sidestream S mainly affects the middle and bottom product, while both L and V have a large effect on x_{S2} . We see quite readily that there will be interaction between the top and bottom composition, in line with ordinary binary distillation.

The singular value decomposition $G = U\Sigma V^T$ (at steady-state) will allow us some conclusions on the high and low gain directions of the plant;

$$G = U\Sigma V^T = \begin{pmatrix} 0.72 & -0.68 & 0.15 \\ -0.69 & -0.69 & 0.21 \\ 0.03 & 0.26 & 0.97 \end{pmatrix} \begin{pmatrix} 244 & & \\ & 15.0 & \\ & & 0.53 \end{pmatrix} \begin{pmatrix} 0.71 & -0.05 & 0.71 \\ -0.71 & 0.03 & 0.71 \\ -0.06 & -1.00 & -0.01 \end{pmatrix}^T \quad (3)$$

The output and input directions are given in U and V , respectively. We see that the high gain direction corresponds to moving the top and bottom compositions in opposite directions, or moving the column composition profile up or down. The low gain direction corresponds to moving them in the same direction, i.e. making both D and B more or less pure. This is in accordance with ordinary distillation. The medium gain direction corresponds almost entirely to changing S and moves x_{S2} opposite to x_{D1} and x_{B3} .

We then look at the interaction and disturbance rejection properties. The steady state RGA values

$$\Lambda(0) = \begin{pmatrix} 12.15 & -11.16 & 0.00 \\ -22.20 & 22.61 & 0.59 \\ 11.05 & -10.45 & 0.40 \end{pmatrix}$$

show again that the control of x_{D1} and x_{B3} interact. The same trend is evident from the frequency dependent RGA as shown in figure 4a. The interaction tapers off at higher frequencies, showing that the control having effect around the bandwidth of the plant will not be much affected by interaction.

The closed loop disturbance gain, CLDG, is shown in figure 4b. The most difficult disturbances to reject are changes in F on x_D and x_B requiring a bandwidth of about 0.25 rad/min (time constant of 4 minutes) in these loops. On the other hand, the required bandwidth for controlling x_{S2} is significantly smaller (less than 0.1 rad/min).

Three-point control works well against the imposed perturbations (at time 2, 8 and 14 hr.) as shown in figure 5.

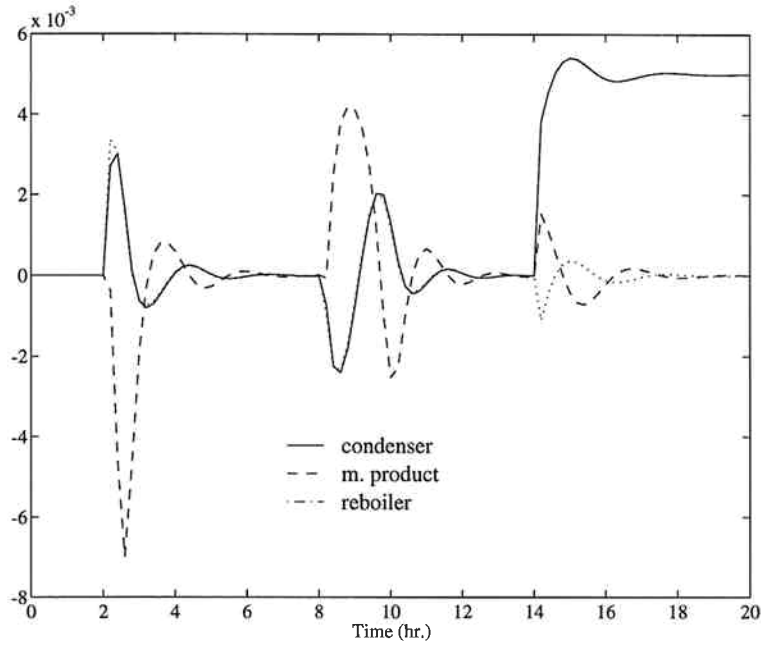

Figure 5: Response to perturbation set, ΔF , Δx_F and $\Delta y_{D1,s}$.

4.3 Problems with three-point control

Although the three-point control seems to work satisfactory from a linear point of view this may be misleading. A more detailed analysis shows that it is not resilient for some larger changes. For example, changing the setpoint for the sidestream purity from 0.99 to 0.995 causes the column to reach constraints on L and V (50% increase on both). This is a result of a large x_{S1} , which occurs due to the small gain between S to x_{S1} . Reducing S will primarily change x_{S3} which is insufficient when x_{S1} becomes large. We therefore would like to use R_L and/or R_V for controlling x_{S1} .

4.4 Four-point control, LVR_LS configuration

We first look at adding R_L as manipulated variable to find a control strategy that includes controlling x_{S1} . The set of measurements and manipulated variables is thus

$$y = \begin{pmatrix} x_{D1} \\ x_{B3} \\ x_{S1} \\ x_{S2} \end{pmatrix} \quad u = \begin{pmatrix} L \\ V \\ R_L \\ S \end{pmatrix}$$

The process gain and RGA at steady-state operating conditions are

$$G(0) = \begin{pmatrix} 124.67 & -124.48 & 0.09 & 0.11 \\ -118.86 & 119.31 & -0.09 & 20.02 \\ 23.44 & -23.64 & -0.09 & -0.21 \\ 5.82 & -5.16 & 0.01 & -4.30 \end{pmatrix} \quad \Lambda(0) = \begin{pmatrix} 25.69 & -24.80 & 0.11 & 0.00 \\ -32.92 & 33.04 & 0.06 & 0.82 \\ 0.71 & -0.56 & 0.85 & -0.00 \\ 7.52 & -6.68 & -0.02 & 0.17 \end{pmatrix}$$

We see that although a suitable pairing exists ($L \rightarrow x_{D1}$, $V \rightarrow x_{B3}$, $R_L \rightarrow x_{S1}$ and $S \rightarrow x_{S2}$) the manipulated variable R_L has a very low gain towards *all* control objectives. The closed loop disturbance gain in figure 6 is very similar to the 3×3 case, giving the same bandwidth requirements for good control.

Using R_V instead of R_L for control gives comparable results, both failing to give good control of x_{S1} .

4.5 Problems with Four-point control

Figure 7a shows how the column becomes unstable when using R_L to control x_{S1} causes R_L to enter the difficult area. The bottoms purity in figure 7b behaves in the same way.

4.6 Other possible control strategies

Since R_L and R_V are independent variables, it is possible to use a combination of the two for control. R_L/R_V and $R_L - R_V$ are the most obvious choices, but both choices unfortunately have low gain to the control objectives.

R_L and R_V describe an almost linear relationship with each other at the chosen operating point. This can be approximately found by considering the net flow from the prefractionator to the main column, for the top connection denoted D_1 . We have $D_1 = V_2 - L_1 = R_V V - R_L L$. Rearranging this with respect to R_L gives;

$$R_L = \frac{V}{L} R_V - \frac{D_1}{L}$$

Since the prefractionator is crucial in separating component **2** from **1** and **3**, controlling compositions leaving the top or bottom of the prefractionator is a possibility. This is possible, although the effect down to x_{S_i} is still diminishing.

Another possibility is to find a plant parameter p that gives a near optimal Q_B over a large range. This could give rise to an optimization scheme where p could be adjusted slowly using R_L or R_V .

5 Discussion

The Petlyuk design has not found widespread use despite acknowledged energy savings compared to conventional direct or indirect design. We have shown here that good control is possible for two and especially three product purity specifications, although it should be noted that the column is more sensitive to increased purity specifications due to the small influence of the manipulated variables on x_{S_1} .

The Petlyuk column has been compared with other ternary distillation column sequences, although none of these have been energy integrated. This comparison should also be performed to give a wider basis on which to judge the Petlyuk column.

Using L_1 and V_2 as manipulated variables primarily affects the distribution of the light and heavy key in the sidestream when the other manipulated variables are held constant. While L_1 and V_2 heavily influence the optimal boilup rate, they do not hold much power for use as manipulated variables in control. This is because they primarily affect the efficiency of the separation in the central parts of the column. Thus, this effect counteracts the effect of using them for controlling the the purity in S .

Controlling the middle component with the sidestream S works well, giving good tracking and disturbance rejection properties. Controlling the purity in the middle of the column is beneficial also for the top and bottom composition control by stabilizing the column profile, giving less interaction between the L and V control loops. Using temperature measurements for control of x_{S_2} should perform well since the temperature will increase monotonously for different impurity distributions (with the composition profile moving vertically).

References

- [1] Cahn, R.P. and A.G. Di Micelli, 1962, U.S. Patent No. 3,058,893 (October 16, 1962).
- [2] Cerda, J. and A.W. Westerberg, 1981, "Shortcut Methods for Complex Distillation Columns. 1. Minimum Reflux", *Ind. Eng. Chem. Process Des. Dev.*, **20**, p. 546-557.
- [3] Chavez, C.R., J.D. Seader and T.L. Wayburn, 1986, "Multiple Steady-State Solutions for Interlinked Separation Systems", *Ind. Eng. Chem. Fundam.*, **25**, p. 566-576.
- [4] Faravelli, T., M. Rovaglio and E. Ranzi, 1989, "Dynamic Analysis and Stability of Interlinked Multi-component Distillation Columns", *Dechema Monographs*, **116**, p. 229-236.
- [5] Fidowski, Z. and L. Krolikowski, 1986, "Thermally Coupled System of Distillation Columns: Optimization Procedure", *AIChE J.*, **32**, 4, p. 537-546.

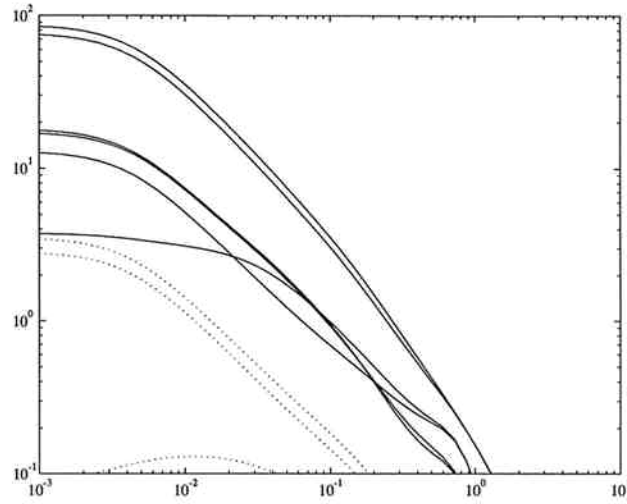

Figure 6: Closed loop disturbance gain for LVR_{LS} configuration

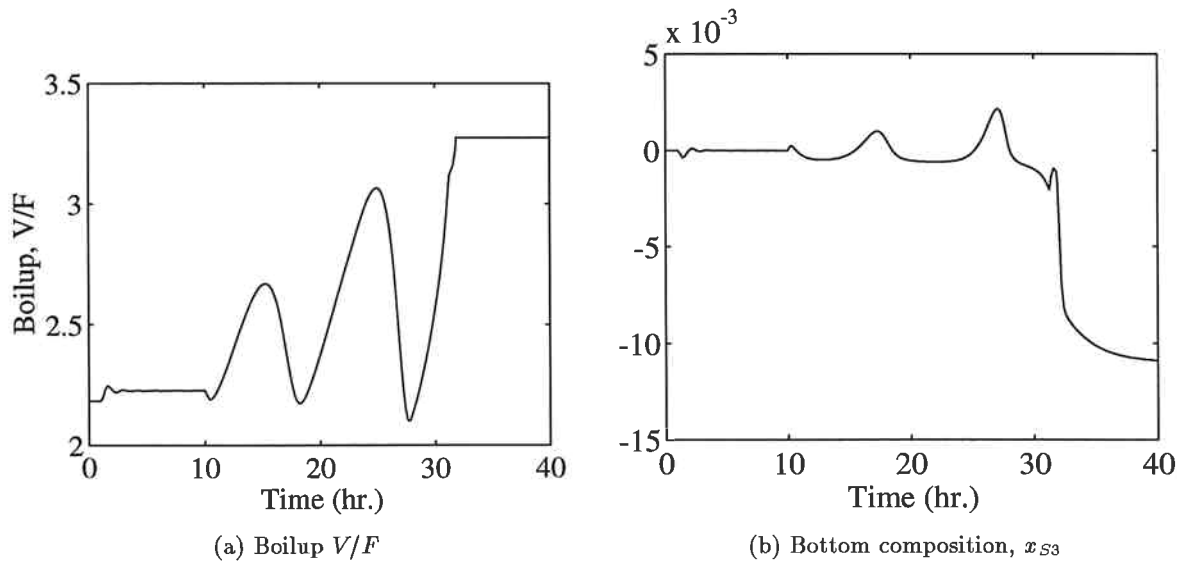

Figure 7: Response to x_{S1} setpoint decrease ($t = 2$) and increase ($t = 10$).

- [6] Glinos, K. and F. Malone, 1988, "Optimality Regions for Complex Column Alternatives in Distillation Systems", *Chem. Eng. Res. Des.*, 66, p. 229-240.
- [7] Grosdidier, P., M. Morari and B.R. Holt, 1985, "Closed-Loop Properties from Steady-State Gain Information", *Ind. Eng. Chem. Fundam.*, 24, p. 221-235.
- [8] Hovd, M. and S. Skogestad, 1992, "Simple Frequency-Dependent Tools for Control System Analysis, Structure Selection and Design", *Automatica*, 28, 5, p. 989-996.
- [9] Petlyuk, F.B., V.M. Platonov and D.M. Slavinskii, 1965, "Thermodynamically optimal method for separating multicomponent mixtures", *Int. Chem. Eng.*, 5, 3, p. 555-561.
- [10] Rudd, H., 1992, "Thermal Coupling for Energy Efficiency", *Chemical Engineer* (Distillation Supplement), 27. august 1992.
- [11] Tedder, D.W. and D.F. Rudd, 1978, "Parametric Studies in Industrial Distillation: Part 1. Design Comparisons", *AIChE J.*, 24, 2, p. 303-315.
- [12] Triantafyllou, C. and R. Smith, 1992, "The Design and Optimisation of Fully Thermally Coupled Distillation Columns", *Trans IChemE*, 70, p. 118-132.