

Configurations of Binary Distillation column for optimal control

Abdelmadjid KHELASSI, Riad BENDIB, Abdelhai BENHALLA

University M'Hamed Bougara of Boumerdes,
 Faculty of Hydrocarbons and Chemistry, Laboratory of Applied Automatic
 E-mail :madjidd@hotmail.com

Abstract- Choice of the control structure is a major concern and considerable research activity has been devoted to finding the best control configuration. In this work eight distillation control structures have been investigated by simulation based on models that are deduced using a software package for distillation column. These programs use transformations between the structures. The Dynamic Relative Magnitude Criterion, DRMC has been used to evaluate the interactions and disturbances propagation between the two interacting controlled loops of distillation column. Comparison between the results given by DRMC and those given by the Relative Gain Array, RGA has been also given in this work.

Keywords: Configuration;, Distillation; Interaction; DRMC; RGA; Optimal control.

I. INTRODUCTION

Recently there has been considerable interest in developing process control strategies for multivariable control system, that is, problems where several process variables are to be controlled and several variables can be manipulated [1]. Although a variety of advanced control techniques are available, only a few industrial applications have been reported. The conventional industrial approach to multivariable control problems is to use a "multiloop control system" consisting of m conventional PI or PID controllers where m is the number of controlled variables [2].

A big part of monovariable control problems can be solved by the classic PID-type compensator and fuzzy

controllers. A number of investigators have developed measures of interaction that allow a control system designer to determine the proper input-output pairing for a set of single-input/single-output (SISO) controllers. There are many cases, however, where the measures of interaction show the absence of an adequate control configuration.

The goal of this paper is to give insight into the different structures of controlling binary distillation column and give the best scheme that allows us to minimise the energy consumed by this column

The configurations considered here are the Energy balance "LV-configuration" [3], the material balance "DV-configuration" [3], the ratio configuration such as (L/D,V/B) (L/D, V/F), (D/ (L+D), V), (L/D, V), (D/ (L+D), V/B), and LB [4], [5], [6].

II. DISTILLATION CONTROL STRUCTURES

A. Energy balance structure (L V)

The energy balance structure can be considered to be the standard control configuration for dual composition control of distillation. In this control structure, the reflux flow rate L and the boil-up manipulator V are used to control the outputs concentrations or temperatures.

A typical distillation column with LV configuration is shown in Fig (1).

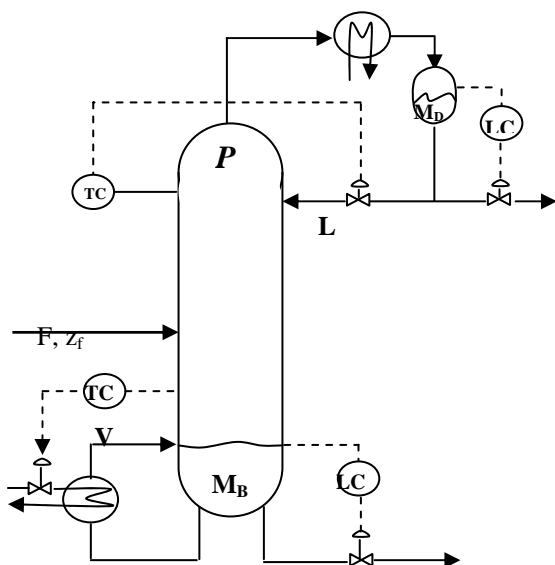

Fig (1) LV configuration

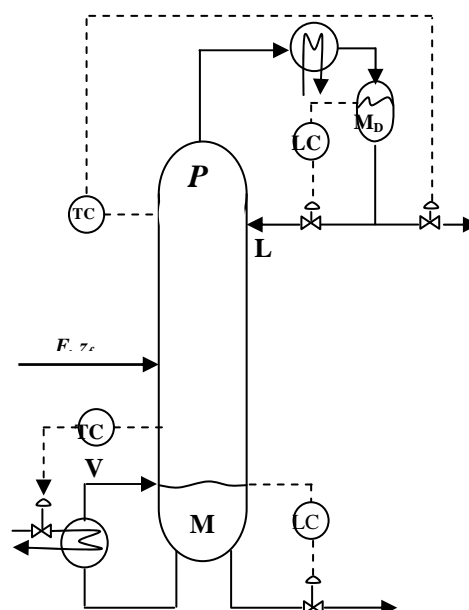

Fig (2) DV configuration

B. Material balance structures (D,V) and (L,B)

Two other frequently used control structures are the material balance structures (D, V) and (L, B). In the (D, V) structure, D and V are used as primary manipulators whereas L and B usually are used as inventory control manipulators. The implementation of this control scheme is shown in Fig (2).

C. The ratios scheme $(L/D, V/B)$

Ratio control configurations have been used in industry for at least forty years [7]. Condenser level is adjusted with both L and D such that their ratio is constant and reboiler level with both V and B such that their ratio is constant. The simplest justification for using ratios as inputs follows from steady state considerations: to keep the compositions constant, the ratio L/V inside the column (slope of the operating line on the McCabe- Thiel diagram [8],[9]) should be constant.

D. The ratios scheme $(L/D, V/F)$

The $(L/D, V/F)$ is an example of a control structure where a primary manipulator include a measurable disturbance. The inclusion of F in the manipulator V/F means that there is such a built-in feed forward from measured disturbances in F that V is changed in the same proportion as F . This results in a better rejection of disturbances in F than is the case in other structures.

E. Ryskamp's control scheme

This control structure is suggested by Ryskamp (10), where the primary outputs are

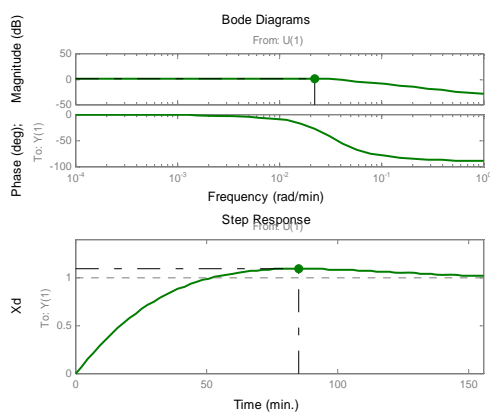

Fig (3-a) The closed loop bode diagram and step response 1st loop (LV scheme)

Controlled by $D/(L + D)$ and V . This scheme holds the reflux ratio constant if the top composition controller is constant. An increase of heat input from the bottom composition controller does not make top product as impure as would occur with reflux constant (conventional control) nor as over-pure as would occur with distillation flow constant (material balance control). Thus, this property of the scheme is sometimes said to result in "implicit decoupling", in contrast to "explicit decoupling" accomplished by external decoupling elements.

F. $(L/D, V)$ structure

This control structure is equivalent to Ryskamp's structure, because $\Delta(D/(L + D)) = -(\bar{D}/(\bar{L} + \bar{D}))^2 \Delta(L/D)$ [7]; the only difference is a different scaling of gains associated with the top primary manipulator.

G. $(D/(L+D), V/B)$ structure

This control scheme is an extension of Ryskamp's structure, is suggested and studied by Takamatsu, Hashimoto, and Hashimoto (11).

III. ANALYSIS OF INTERACTIONS IN THE LISTED STRUCTURES USING DRMC

A. Conventional control structure (LV) Configuration

To specify parameters for the PI controllers root locus method has been used. In our case the design objective is to get a closed loop response where the percent overshoot is small or equal to 07% . The closed loop step responses and bode diagrams for both loops are shown in Fig(3),

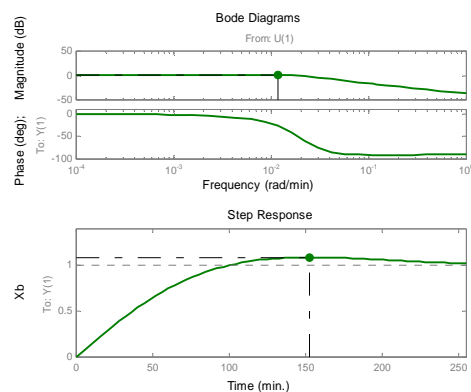
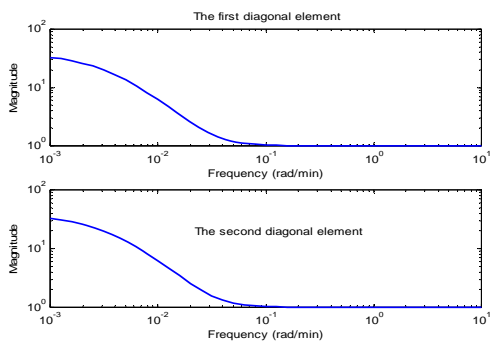

Fig (3-b) The closed loop bode diagram and step response 2nd loop (LV scheme)

As it is shown in Fig (4) the magnitude of the diagonal elements for the range where the system works (i.e. the

resonant frequency) are far from unity δ_{11} and $\delta_{22} \approx 7$ which means that strong interactions exist between the loops, the fact that let the (LV) configuration to be not recommended for two point control (i.e. where all loops are in automatic). The off-diagonal elements $\delta_{12} = 0.8$ and $\delta_{21} \approx 1$ in the resonant frequencies which indicate that there exist large disturbances between the two loops and propagate approximately by the same magnitude.



Fig(4) The DRMC diagonal elements

B. Material balance (D,V) structure

The DRMC values, the diagonal elements

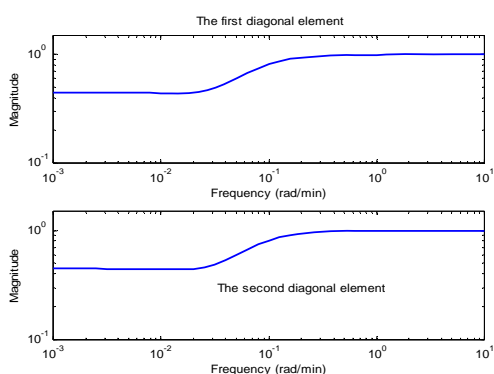

Fig(5) The DRMC elements of DV configuration

The distillation column under this configuration is slightly interactive as it is indicated by the DRMC diagonal elements shown in Fig (5) (δ_{11} and $\delta_{22} = 0.45$ are close to unity). For the off-diagonal elements we notice that $\delta_{21} = 0.1, \delta_{12} = 0.09$ i.e. $\delta_{21} > \delta_{12}$ which means that there exist disturbances that propagate from the top loop to the bottom loop. In general this configuration is a good choice in the sense of interactions but in reality there are problems that affect the operation of the column under this control scheme [7],[12], the major problem that may rise with this configuration is the effect of level control, such that with fast condenser level control, the increase in boil-up goes up the column, then returned back as a reflux through the action of the condenser level controller (since D is constant), and we have an increase in the internal flows only.

C. Material balance (L,B) structure

The DRMC elements, the diagonal elements

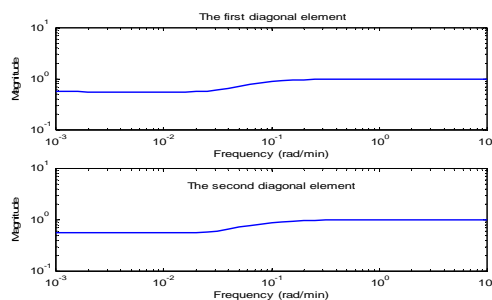

Fig(6) The DRMC diagonal elements LB configuration

The distillation column under this configuration is almost non-interactive as it is indicated by the DRMC diagonal elements shown in Fig (6) (δ_{11} and $\delta_{22} = 0.6$ are close to unity). For the off-diagonal elements $\delta_{21} \approx \delta_{12} = 0.1$ which means that there are disturbances that propagate between the loops by the same magnitude. As the first material balance configuration there is a problem of level control, another practical problem is that this configuration is extremely sensitive to disturbances in feed flow rate [7].

D. The two ratios scheme ($L/D, V/B$)

The DRMC values, the diagonal elements

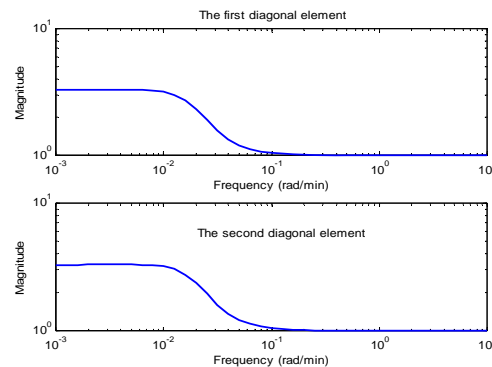

Fig(7) The DRMC diagonal elements (L/D V/B) configuration

The distillation column under this configuration is interactive as it is indicated by the diagonal elements of the DRMC shown in Fig (7) (δ_{11} and $\delta_{22} = 3.2$), but compared with the energy balance configuration the degree of interactions is smaller (this also can be deduced using the RGA). The examination of the off-diagonal elements show that ($\delta_{21} = 0.6$) is greater than ($\delta_{12} = 0.35$) which indicates that there is disturbance propagation from the top loop to the bottom loop. The main disadvantages of this configuration is the need for measurements of all flows L, D, B and V which

makes it more failure sensitive and more difficult to implement.

E. The two ratios scheme $(L/D, V/F)$

The $(L/D, V/F)$ model is deduced from the LV steady state model.

The DRMC values, The diagonal elements

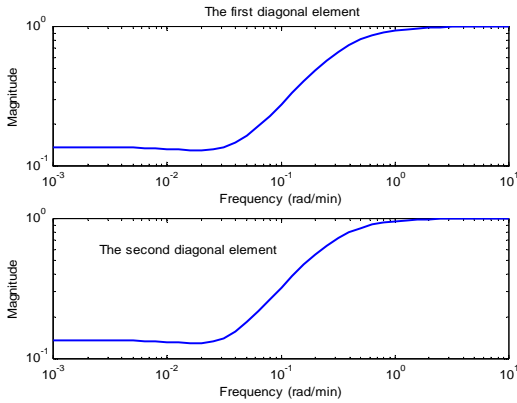
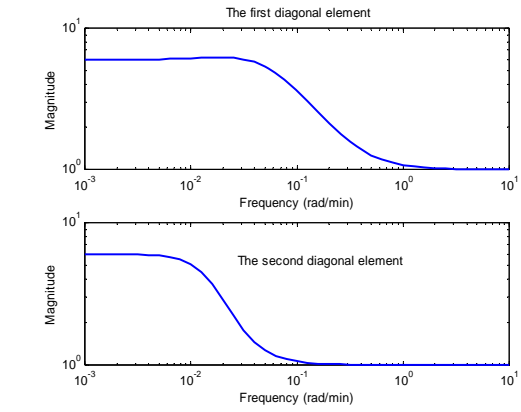

Fig (8) The DRMC diagonal elements $(L/D, V/F)$ configuration

The examination of DRMC values (at the resonant frequencies) shows that $(\delta_{11}$ and $\delta_{22} \approx 0.15)$ which indicates that more interaction compared with the previous two ratios configuration is expected, for the off-diagonal elements $(\delta_{21} = 0.2)$ is greater than $(\delta_{12} \approx 1.6 \times 10^{-2})$ which indicates that there exists a disturbance propagation from the top loop to the bottom loop, in general we can say that this configuration behaves between the (DV) and $(L/D, V/B)$, but in this configuration we avoid the disturbances created by the flow rate (because F is included in the primary manipulator). The major drawback for this control scheme is the need of measurements for all flows which makes it more difficult to implement.

F. Ryskamp's scheme $(D/(L+D), V)$

The DRMC values, the diagonal elements



Fig(9) The DRMC diagonal elements Ryskamp's configuration

The diagonal elements at the resonant frequencies shown in Fig (9) are far from unity δ_{11} and $\delta_{22} = 5.5$, but there values are small compared with those of LV control scheme, which indicates that the degree of interactions exist in this configuration is small compared with conventional control, this is according to decoupling (implicit) effect which results from the property that the scheme holds the reflux ratio constant if the top composition controller is constant. The DRMC off-diagonal elements that indicate that there is a large disturbance propagation from the bottom loop to the top loop (since $(\delta_{12} = 0.6) > (\delta_{21} = 0.1)$).

G. The $(L/D, V)$ control scheme

The properties of $(L/D, V)$ structure are similar to those of the $(L/D, V/F)$ structure, particularly in our case where the feed rate is $F = 1$. The $(L/D, V)$ model is deduced from the LV steady state model.

H. The $(D/(L+D), V/B)$ control structure

The DRMC values, the diagonal elements

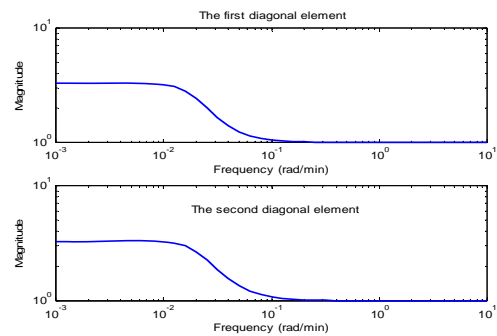

Fig (10) The DRMC diagonal elements $(D/(L+D), V/B)$ configuration

Fig (10) presents DRMC diagonal elements for this structure, the examination of the diagonal elements shows that there exist interactions between the two loops, but with a magnitude smaller than those of Ryskamp's scheme ($\delta_{11}, \delta_{22} = 3.2$) (this is what Shinsky (1984) and Hashimoto have shown [7]), and disturbances propagate from the top loop to the bottom loop as it is given by the off-diagonal elements ($\delta_{21} = 0.5$) > ($\delta_{12} = 0.3$)

IV. ANALYSIS OF INTERACTIONS USING RGA

TABLE I
COMPARISON BETWEEN THE RGA VALUES AND DRMC VALUES FOR THE STUDIED STRUCTURES

Structure	λ_{11}	δ_{11}
LV	36.06	7
DV	0.446	0.45
LB	0.56	0.6
(L/D V/B)	3.28	3.2
(L/D V/F)	5.98	0.15
Ryskamp's	5.98	5.5
(L/D, V)	5.98	0.15
(D/(L+D) V/B)	3.28	3.2

As it is shown in Table I, there are deviations between the values given by the RGA and those given by the DRMC, since the first method gives information about the steady state behavior of the system, whereas the DRMC deals with the dynamic behavior of the system.

CONCLUSION

In order to overcome the problem of interactions several distillation control schemes are suggested by many contributors. DRMC is used to assess interactions in eight well known control configurations for binary distillation columns. The mathematical model for each configuration is deduced by using transformations between control schemes taking the (LV) configuration as a base model. It has been shown from the analysis that the conventional control structure (LV) suffers from severe interactions the diagonal elements are far from unity and the off diagonal elements show that there exist large disturbances that propagate between the loops approximately by the same magnitude. The material balance control (DV) is non-interactive the diagonal elements are close to unity, the off diagonal elements show that there exist disturbances that propagate from the top loop to the bottom loop since $\delta_{12} > \delta_{21}$, the same remark with the second material balance (LB) the diagonal elements are close to unity which indicates that for this configuration low interaction is expected, the off diagonal elements show that

there exist disturbances that propagate between the loops by the same magnitude.

The ratio schemes are introduced to reduce the degree of interactions exist in the conventional control scheme (LV) and that is what it has been shown using DRMC for the remaining control schemes. For the two ratios control scheme (L/D, V/B), (L/D, V/F) and (L/D, V) are non-interactive with respect to (LV) control (as it is indicated by the DRMC diagonal elements for the three cases). Ryskamp's configuration is an interactive one but with smaller degree than that of (LV) control scheme, the larger degree of interaction in Ryskamp's has been reduced using its extension control scheme i.e. (D/(L+D), V/B).

REFERENCES

- [1] Agamennoni.O.E and Figueroa.J.L "Advanced Controller Design For Distillation Column" INT.J. Control, Vol.59,N°3,817-839,1994.
- [2] Atle. C and Lien. C " Complex Distillation Arrangements "ESCAP, Trondheim 1997.
- [3] R. Bendib "Control configurations and assessment of interactions in distillation columns" Master thesis, FHC, Boumerdes University, Algeria, 2004.
- [4] Dadhe. K, Engell.S and Gesthuisen.R "Control Structure Selection For a Reactive Distillation Column" IFAC 2002.
- [5] Esref .E "Consistency Relations In Process Modeling" IFAC 2002.
- [6] Ioannis k. kooks, J.D. Perkins "An Algorithmic Method For The Selection Of Multivariable Process Control Structures" J.O.Process Control, 85-89, 2002
- [7] Luyben. W "Practical Distillation Control ",Nostrand Reinhold 1992.
- [8] King "Separation Process" Second edition Mc Graw Hill 1980
- [9] Luyben.W "Process Modeling, Simulation And Control For Chemical Engineers" 2nd edition, Mc Graw Hill 1990.
- [10] Seborg Dalee " Process Dynamics And Control " John Wiley and sons 1989.
- [11] Takamatsu.T and Hashimoto. I " Non-Interacting Control System Design Of A Distillation Column By The Partial Model Matching " IFAC 1986
- [12] Skogestad.S " Dynamics and control of distillation columns" Trans.IChemE, Vol.75,part A,1997.