

Online Slug Detection in Multi-phase Transportation Pipelines Using Electrical Tomography^{*}

Simon Pedersen, Christian Mai, Leif Hansen, Petar Durdevic,
and Zhenyu Yang

*Department of Energy Technology, Aalborg University Esbjerg, Niels
Bohrs Vej 8, 6700 Esbjerg, Denmark (E-mail: spe@et.aau.dk)*

Abstract: Slugging flow in offshore oil & gas multi-phase transportation pipelines cause big challenges as the flow regime induces flow and pressure oscillations in the multi-phase pipelines. The negative impacts of the most severe slugs are significant and thus the elimination of slugging flow in the pipelines is a highly investigated topic. To eliminate the slug in an online manner real-time slug detection methods are often required. Traditionally topside pressure transmitters upstream a 3-phase separator have been used as the controlled variable. In this paper Electrical Resistivity Tomography (ERT) has been examined as an alternative to the traditional pressure transmitters. A lab-scaled testing facility has been constructed in order to obtain test data from a ERT transmitter with 12 probes. Different flow regimes have been generated by a pump and a compressor where 2-phase flow can be tested. Based on the results the study concludes that the ERT is able to detect the slug very well when the oil and water is well mixed. Furthermore the traditional pressure transmitters have the limitation that pressure variations can be caused by other operating conditions than slug, such as change in the back pressure from control valves. The biggest limitation using ERT is the lack of ability to distinguish between gas and oil, and thus the ERT can only be used as an effective slug detect measurement when the oil-to-water ratio is low.

Keywords: Offshore, oil & gas, anti-slug, multiphase flow, fault detection.

1. INTRODUCTION TO OFFSHORE SLUG

In many years the production rate optimization for offshore oil and gas transportation facilities has been heavily investigated, as the possible production increase has proven great potential (Havre et al. (2000)). Figure 1 from Yang et al. (2014) shows a typical transportation pipeline section for offshore oil fields upstream the separation platform. The complete pipeline system can be divided into three subsections:

- (1) The liquids, gases and solid materials from the reservoir flows through a vertical well. The wells often uses artificial lifting controlled by choke valves to lower the hydrostatic pressure in the well caused by the oil and water from the reservoir. Often a topside choke valve is also available.
- (2) The well is connected to a long horizontal transportation pipeline following the sea bed. As the maintenance of subsea equipment is very expensive there often exist no actuators or transmitters in this section.
- (3) Another vertical riser is connected to the sea bed pipeline. This crosses the sea level to connect the pipeline to the separation process on a separation platform. Here a topside choke valve is often placed before the separator.

^{*} Supported by the Danish National Advanced Technology Foundation through PDPWAC Project (J.nr. 95-2012-3).

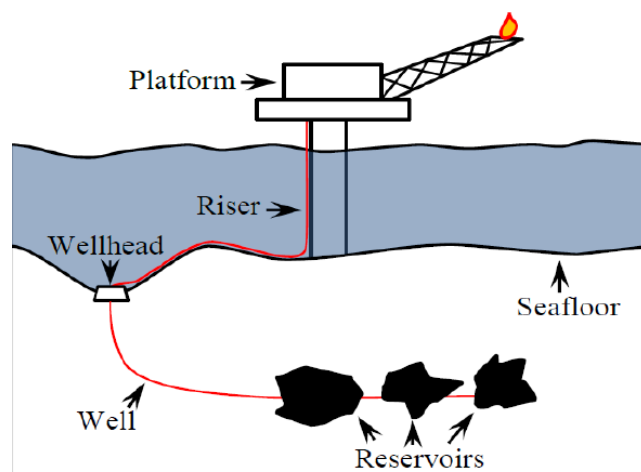

Fig. 1. From Yang et al. (2014). Schematic of the multiphase transportation pipeline in the upstream of rig-based separation. The system can be divided into three parts: (i) The well, (ii) the transportation pipeline following the seabed, and (iii) the riser to a separation platform.

This complete pipeline system is often referred to as the well-pipeline-riser system (Yang et al. (2013)). It is observed that nearly the entire pipeline section is placed sub-sea. As all maintenance of subsea equipment is both very expensive and time-consuming the number of pipelines,

actuators, transmitters and separation equipment are very limited before the separation platform. On many platforms only a few pressure and temperature transmitters are used for the purpose of flow control in the transportation pipeline section. In some cases flow transmitters are used as well.

Slugging is a common flow pattern in multiphase flow systems, such as in the oil & gas production process. Slug occur when the gases and liquids not are evenly distributed throughout the wells, transportation pipelines or risers under given operating condition. Sometimes the liquid and gas travel as large plugs through the pipeline. This phenomenon is referred to as *slug*. The negative consequences of having severe slugging flow conditions in the transportation pipelines have been studied by Hill and Wood (1994). The study concludes that the main negative impacts of the slug are: Liquid overflow and high pressure in the separators (see Husveg et al. (2007)), overload on gas compressors, fatigue caused by repeating impact, high frictional pressure drop, low production, and production stop. Hence it is clear that avoiding the slug is of big economic interest.

Often the severe slug is defined as a big amplitude in the pressure, temperature and flow oscillations, hence minimizing the pressure, temperature and flow amplitudes will reduce the severe negative impact from the slug (Pedersen et al. (2014)). As only few offshore platforms have flow transmitters available upstream the first stage separator, the slug detection relies solely on the well temperature and pressure measurements (first section in figure 1) and the riser topside temperature and pressure measurements (third section in figure 1). Often more wells are combined into a single multi-phase transportation pipeline and thus the individual well measurements are hard to use for the severe slug detection. Besides, the riser induced slugs can both occur in the well and in the riser. Of the two topside measurements the pressure transmitter is typically the one used as the slug indicator (Jahanshahi (2013)). However, using the topside pressure measurement as the slug indicator can cause problems as pressure variations can be caused by other operating conditions than slug. Increase of back pressure in the separator or a switching between two separators (often more separators can be linked in series or parallel) can falsely indicate the occurrence of severe slug. For this reason an alternative to the topside pressure transmitter can potentially improve the reliability of the slug detection.

In this paper an Electrical Resistivity Tomography (ERT) transmitter is going to be experimentally examined with the purpose of online slug detection as an alternative to the topside pressure transmitters currently applied on most offshore platforms. The ERT analysis will be made on a 2-phase lab-scaled testing facility, where gas and water are being used to examine the ERT transmitter for 2-phase flow. In offshore transportation pipelines the liquid phase is often a mixture of water and oil, where the oil-to-water ratio decrease over time due to waterflooding in the reservoir. Thus in this paper it is assumed that the liquid mixture of oil and water is well-mixed and the oil-to-water ratio is low as on mature reservoirs. With these assumptions the 2-phase pipeline testing facility will be sufficient to test the efficiency of the ERT technique.

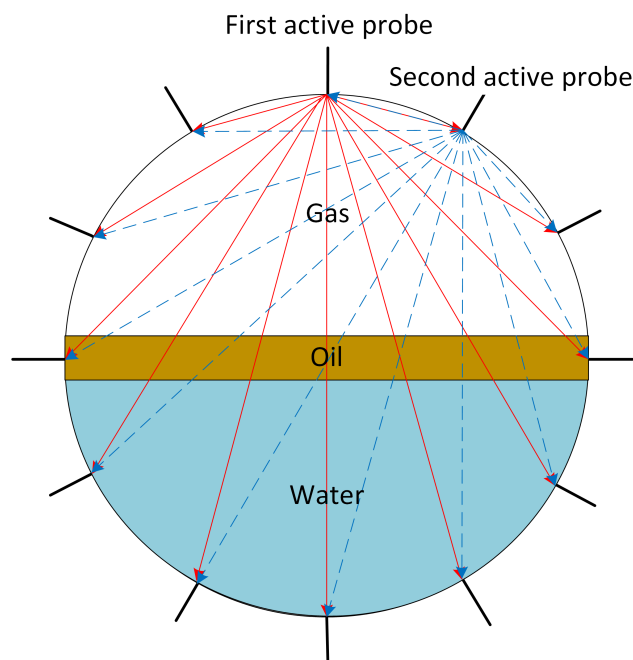

Fig. 2. The tomography transmitter from a cross section perspective. During the first sample the first active probe is sending out a current signal illustrated by the red line over the pipeline cross section. During the second sample the second active probe is providing the signal and the blue line indicates the current running through the pipeline during that sample.

2. ELECTRICAL RESISTIVITY TOMOGRAPHY

Tomography is the general term for a technique to visualize information over a cross-sectional segment of a pipeline. Tomography data can be obtained based on several different measurement techniques, such as electrical, radioactive, optical, microwave, ultrasonic and magnetic resonance. One of the most well-known application of the tomography is the MRI scanning using magnetic resonance mainly applied for medical imaging (Ismail et al. (2005)). This paper will focus on electrical tomography, as this method is a cheap and simple technique to implement for oil & gas production applications. The electrical resistivity tomography (ERT) measures the resistivity over a pipeline which might consist of two or more components with different electrical characteristics.

ERT has previously been applied for water-air mixture multi-phase flow. Xu et al. (2009) examined the application of ERT for gas-liquid slug detection in a horizontal pipeline and concluded from experiments that ERT was a reasonable method for slug flow measurement. Denga et al. (2011) examined a simulation study of sensor fusion between an electromagnetic flowmeter and ERT focusing on slug flow in vertical pipelines to obtain a more reliable slug measurement. However the the study also concluded that the efficiency of the proposed sensor fusion technique heavily relies on the accuracy of electromagnetic flowmeter during vertical slug flow, which can be a problem for real applications, especially if there also exist oil in the mixture. Williams et al. (1999) proved that an air core can be detected in a hydrocyclone by usage of ERT, hence the

flow pattern does not necessarily need to be stratified to be detected by ERT.

Figure 2 is an illustration of an ERT transmitter with 12 probes, similar to the transmitter used in the experiments developed in this paper. At each sample one of the probes is set to be the active probe and meanwhile the 11 other probes are passive. The active probe gives a 5 voltage signal over the system, and the voltage drop, v_m , is then measured from the active probe to each of the passive probes. All the passive probes are also measuring a current signal, i_m , and by applying Kirchoff's current law it is known that the same current is flowing through the pipeline. Thus the resistance, r_m , and conductance, G_m , from the active probe to any of the passive probes can be calculated using Ohm's law:

$$r_m = \frac{v_m}{i_m} \quad (1)$$

$$G_m = \frac{1}{r_m} \quad (2)$$

At the next sample another probe is active as seen on in figure 2 and the rest is passive. After 12 samples all the probes have been active once and a complete grid can map the resistance over the pipeline cross-section. The subscript m denotes a single measurement in the set of all measurements for this map, 132 in this case. Thus more probes can give a better resolution but also require more samplings and computation load to obtain this resolution.

In order to remove bias from measurement, the bias are calculated from a data set recorded with the pipeline completely full of water. The bias for each voltage measurement are calculated based on the average voltage of all measurements of the same type, either active or passive. The current bias are similarly calculated based on the average of all currents. These calculated bias are then subtracted from measurements in all maps in the future experiments.

2.1 Algorithm

The algorithm is based in a 2-D plane representing the cross-section of the pipe at the point of all the electrodes. The origin of the plane represent the center of the cross-section, while the 2-axes represents the width and the height of the pipe respectively. The size of the pipe is normalized such that the radius is equal to 1.

The position of each electrode is represented by a point in this plane. For each measurement a line segment, l_m , between these points is defined.

In order to get a normalized conductance per length unit, g_m , each of the measured conductances G_m is multiplied with the distance between the electrodes, d_m .

$$g_m = G_m \cdot d_m \quad (3)$$

For each point in the plane, \mathbf{x} , an interpolated conductance per length unit, $g(\mathbf{x})$, is calculated as a weighted average of g_m , which is inspired by Shepard's method, see Shepard (1968).

$$g(\mathbf{x}) = \frac{\sum_{m=1}^M w_m(\mathbf{x})g_m}{\sum_{m=1}^M w_m(\mathbf{x})} \quad (4)$$

Where M is the number of measurements, 132 in this case. The weight, $w_m(\mathbf{x})$ is defined as:

$$w_m(\mathbf{x}) = \frac{1}{D(\mathbf{x}, l_m)^u} \quad (5)$$

Where the constant u controls how much the influence of each measurement decreases with distance. According to Shepard (1968) $u = 2$ is suggested, while Lukaszzyk (2004) noted that $u > 2$ usually is assumed and $u > 1$ is needed for a smooth interpolation function. Here a value of 2 is applied.

$D(\mathbf{x}, l_m)$ is an adaptation of Lukaszzyk-Karmowski probability metric for a distance between two random vectors according to Lukaszzyk (2004).

For each measurement a new set of axes (y_1, y_2) is defined with the active electrode as origin, the y_1 -axis is on l_m and has positive direction towards passive electrode, the y_2 -axis is parallel with the orthogonal projection of \mathbf{x} onto the line segment l_m on the y_1 -axis and has positive direction from l_m to \mathbf{x} .

The point \mathbf{x} is described by Dirac delta distributions, i.e. an exact value:

$$f_{\mathbf{x},1}(y_1) = \delta(y_1 - d_{ap}) \quad (6)$$

$$f_{\mathbf{x},2}(y_2) = \delta(y_2 - d_{xp}) \quad (7)$$

Where d_{xp} is the distance between \mathbf{x} and its orthogonal projection on l_m , while d_{ap} is the distance between the active electrode and this projection.

The line segment is described by an uniform distribution in y_1 and a Dirac delta distribution in y_2 :

$$f_{l,1}(y_1) = \begin{cases} \frac{1}{d_m} & \text{if } 0 \leq y_1 \leq d_m \\ 0 & \text{otherwise} \end{cases} \quad (8)$$

$$f_{l,2}(y_2) = \delta(y_2) \quad (9)$$

The definition of $D(\mathbf{x}, l_m)$ in equation 10 is valid for independent marginal distributions.

$$D(\mathbf{x}, l_m) \equiv \left(\sum_{i=1}^2 \left(\int_{-\infty}^{\infty} \int_{-\infty}^{\infty} |y_a - y_b| f_{\mathbf{x},i}(y_a) f_{l,i}(y_b) dy_a dy_b \right)^p \right)^{\frac{1}{p}} \quad (10)$$

Resulting in equation 11.

$$D(\mathbf{x}, l_m) = \left(\left(\frac{d_{ap}^2}{d_m} - d_{ap} + \frac{d_m}{2} \right)^p + d_{xp}^p \right)^{\frac{1}{p}} \quad (11)$$

Where p defines which p-norm is used to get the vector norm, as this vector represents a physical distance the 2-norm is used.

3. FLOW EMULATION ON TESTING FACILITY

A testing platform has been constructed to test different flow patterns. Two actuators are being used to recreate the different flow pattern characteristics: A pump for the liquid phase and a valve after the compressor for the gas phase. The compressor valve also has a flow transmitter integrated such that the flow rate can be controlled. After the pump an electromagnetic flow transmitter is installed, hence the liquid flow rate can also be controlled. Note that an electromagnetic flow transmitter cannot handle oil or gas, but only single-phase water. The liquid and gas phases are mixed into a single multi-phase pipeline, where the ERT transmitter and a coriolis flow transmitter are connected in series. Two pressure transmitters can

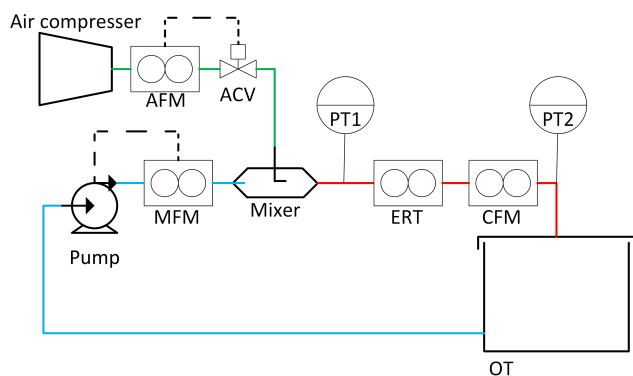

Fig. 3. The lab-scaled testing facility. A pump controlled water-phase is mixed with a valve controlled gas-phase, before a horizontal pipeline section, where pressure transmitters (PT), a ERT transmitter and a coriolis flow transmitter (CFM) can be used for the flow estimation.

measure the pressure drop over the ERT and Coriolis flow transmitter. The multi-phase flow is separated in an open tank which also acts as the liquid reservoir. On figure 3 the test facility design is shown. Note that the system cannot be pressurized, thus the pressure measurements can only be increased by an increase in the mass flow injection from either the pump or the compressor.

To generate the riser-induced slugs on the lab-scaled testing facility the behavior of the riser is emulated by the pump and the compressor valve. Both the pump and compressor valve are controlled with a 0 to 10 voltage signal. Figure 4 shows the two voltage inputs during one slug cycle. The slug can be divided into 4 sections which repeats in a cyclic manner:

- (1) The pressure build-up phase. Here there are no production as the gas is blocked upstream the riser and the liquid column is building up in the vertical riser. Thus neither the pump or compressor are providing any flow injection.
- (2) The pressure is still building up at the riser bottom, however now the liquid column has filled the riser and thus a small liquid production will occur. This is emulated with the pump running at 50% speed.
- (3) The blowout phase. Here the gas pressure amplitude has accumulated enough to push the entire liquid column out of the riser. First only liquid is penetrating through the riser, until a mixture of liquid and gas will blowout. This is emulated by full pump speed and full compressor speed after a short period of time.
- (4) The final step of the blowout phase. Only the accumulated gas will penetrate through the riser while some of the liquid will fall back down the riser to block the gas and thus the cycle repeats. This is emulated by the voltage over the compressor gradually decreases.

It has to be noted that figure 4 only shows the voltage signal given to the actuators. The actual flow rates change over time as first order systems with fast time constants, however the pipeline section cause a small time delay where the amplitudes depend on the flow conditions in the pipeline.

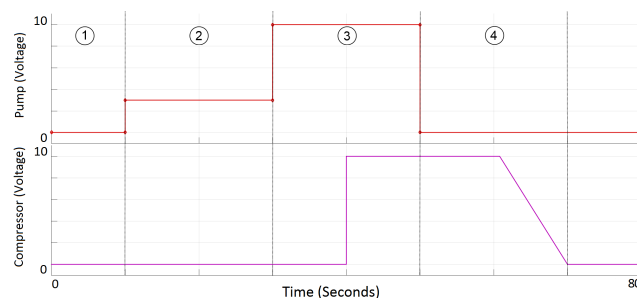

Fig. 4. Emulation of severe riser-induced slugs using a pump for the liquid and a compressor for the gas. The top graph is the pump and the bottom graph is the compressor. Both signals are controlled in a range from 0 to 10 voltage. The slug cycle is divided into 4 sections.

4. CONCENTRATION DETECTION UNDER STRATIFIED FLOW

The first test is made to illustrate the ERT's ability to detect different liquid-to-gas concentrations under laminar stratified flow. This is done by varying the air and water injections into the testing facility. Figure 5 shows the test where laminar stratified flow is examined under different water-to-air ratios. This is emulated by stepping the pump and gas valve inputs, see figure 5a. This results in pressure and flow increase (see figure 5b) with small declines whenever the gas is reset to zero simultaneous with a new step increase for the pump. The pressure follow the same tendency as the pressure difference as the last pressure transmitter will measure near atmospheric pressure due to its location close to the open separation tank. Note that the transmitters have a time delay to an input signal change. This is caused by the actuator dynamics and the transport delay in the pipeline section. Figure 5c shows the mean conductance over the entire pipeline cross-section measured with the ERT transmitter. It can be observed that the ERT detects the slowly increasing gas injections with decreasing mean conductance. High gas velocity induce wavy flow in the pipeline which can be observed as high frequency variation in the mean conductance when the gas injection increases.

Figure 5d, 5e and 5f are illustrating the tomography cross-section images from 10, 50 and 75 seconds indicated by the black vertical lines on figure 5a, 5b and 5c. Image 1 is easy to distinguish from Image 2 as the higher liquid velocity causes the pipeline to be filled with liquid causing the mean conductance to change. Image 3 however is hard to distinguish from image 1, even though the flow rates are much higher on image 3.

Hence the test clearly indicate that the ERT can detect different water-to-air ratios under laminar stratified flow, but cannot detect a change in the flow rates if the ratio remains constant. The wavy flow however can be detected as variations in the mean conductance.

5. ERT FOR SLUG DETECTION

The riser-induced slugs are characterized by the gas and liquid phases coming in pulses, thus under slugging flow the pipeline is switching between being full of gas and

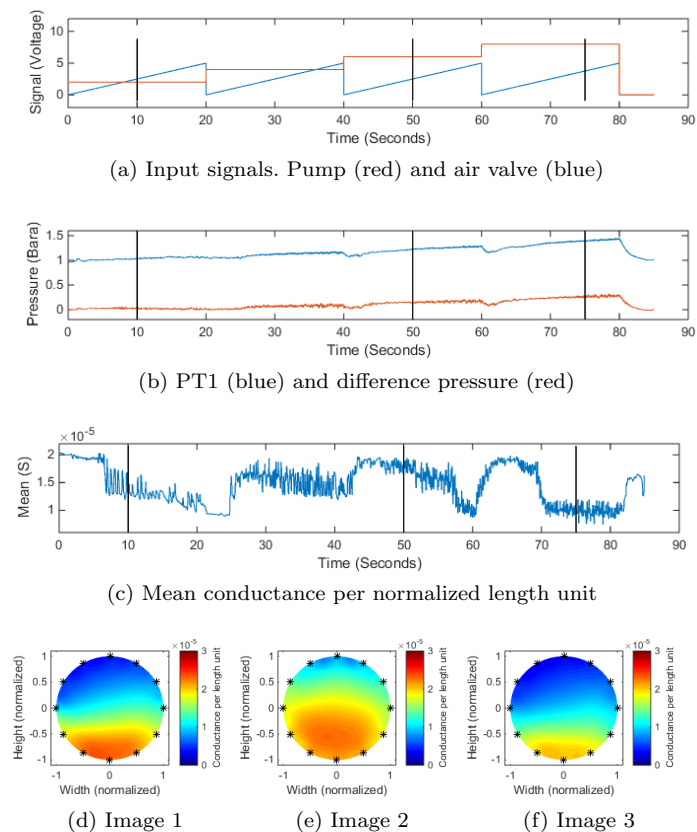

Fig. 5. A test where the inputs are increased by stepping the pump and ramping the air valve. This results in different stratified flows, where 5d, 5e and 5f are the tomography cross-section images from 10, 50 and 75 seconds indicated by the black vertical lines.

liquid. Hence for examination of water and gas as the multi-phase flow the average resistance (and conductance) over the entire pipeline cross-section will vary as well. Thus the ERT has to evaluate how the conductance in the pipeline change over time. Figure 6 shows a slug cycle experiment (generated as described on figure 3) to validate the ERT transmitters performance during big variations in both flow rates and varying water and air concentrations. Figure 6b shows an increase in pressure when the liquid blow-out phase starts and slowly decreases as the liquid injection stops, however the pressure can hardly detect the small liquid production prior to the blow-out. Thus the pressure can detect the slug when the blow-out begins. Figure 6c shows the mean conductance measured by the ERT transmitter. Here it is clear that conductance changes already when the small liquid production begins prior to the blow-out. Hence the ERT can detect the slug faster than the pressure transmitters. It is also clear that the mean conductance rapidly decreases as soon as the gas penetrates through the pipeline during the blow-out phase. Thus the ERT has problems differing the gas blow-out and the non-production stages of the slug cycle. Although it can be observed that there is more fluctuations during the blow-out phase, consequently this phase is detectable. Figure 6d, 6e and 6f shows three still images from the test where it is easy to distinguish the difference phases of a slug cycle.

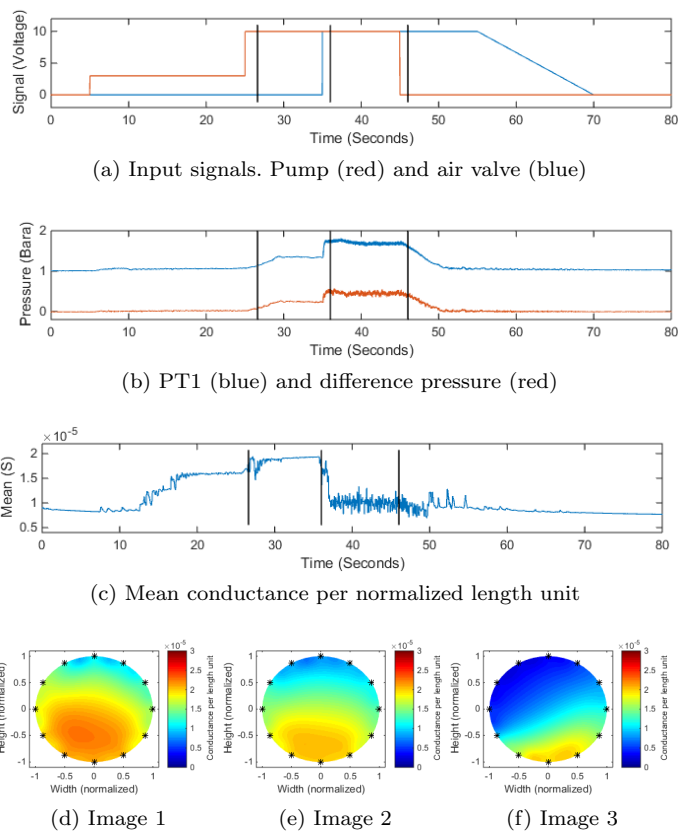

Fig. 6. One emulated slug cycle lasting 80 seconds based on the emulation description from figure 4. The pressure, pressure difference and mean conductance measured by the ERT can all detect the slug.

The slug frequency and amplitude on real offshore platforms change according to the size, length and the flow conditions in the pipelines. For this reason another slug test has been carried out where the frequency of the slugs vary. The amplitude is not changed as the pump and compressor already is saturated to generate a reasonable blow-out amplitude. This test can be observed on figure 7. As in the previous test both the pressure and mean conductance seem to be able to detect the slug. In this test the slug frequency does not seem to effect the transmitters ability to handle the slug. As long as the amplitude is significant both the pressure and ERT transmitters can detect the slug.

6. CONCLUSION AND FUTURE WORK

The paper has described the problems related to slugging flow, and examined what characterizes the severe riser induced slugs. ERT has been suggested as an alternative to the topside pressure transmitter for detection slugging in the transportation pipeline systems. A lab-scaled testing facility has been used to investigate a ERT transmitter. For the pressure transmitters false alarms can happen if the operating conditions change thus causing a pressure change. The ERT results showed that this problem is not as dominant as the method only measures the ratio between water-to-air/oil and not the flow or pressure. However ERT has a limitation as the oil can be mistaken as gas because the materials have close to the same resistance, meaning this can give false results as well. If the ERT

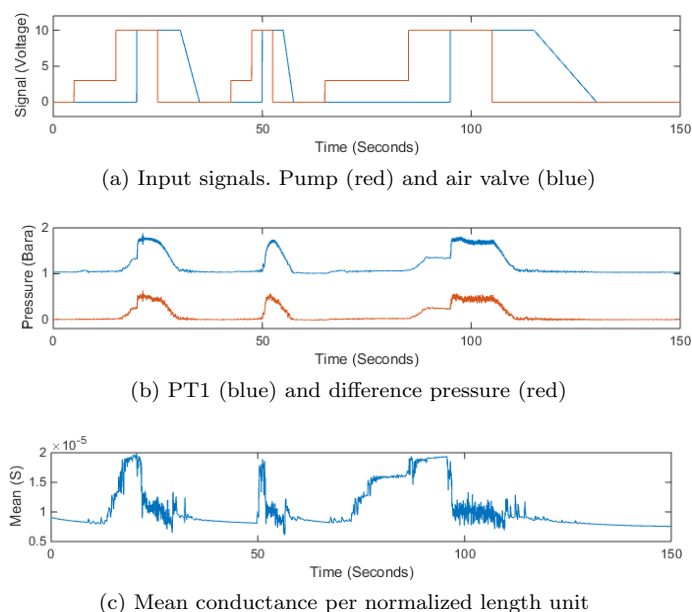

Fig. 7. Three emulated slug cycles with different frequencies. All measurements including the ERT can detect all three slugs.

transmitter is implemented on mature production wells where waterflooding has been using for a long time, the oil-to-water ratio is low and thus the method can be used without big uncertainties.

As the experimental study examined in this paper is based on water-air 2-phase tests, it is assumed the liquid phase is well-mixed and the oil-to-water ratio is low. One test shows that the ERT easily can detect different liquid-to-gas concentrations under stratified flow. For the same test the pressure transmitters estimate the combined flow rate better than the ERT transmitter, but are unsuccessful in detecting the ratio between liquid and gas.

In addition, two slug emulation tests show that both the pressure and ERT transmitter can detect the slug. The slug frequencies does not seem to influence any of the transmitters ability to detect the slug as long as the slug amplitude is sufficient. It is however observed that the ERT can detect slug faster than the (topside) pressure transmitter, but that the ERT also is more sensitive to the gas penetration, especially during the gas blow-out. The ERT's ability to detect slug fast is observed to be equivalent to the coriolis flow transmitter installed on the test setup as they both detect the small flow rate prior to the blow-out. Thus the results indicate that the ERT can be an effective methods to detect the slug, but not necessarily better than a topside pressure transmitter.

ACKNOWLEDGEMENTS

The authors would like to thank the support from the Danish National Advanced Technology Foundation (via PDPWAC Project (J.nr. 95-2012-3)). Thanks also go to our colleagues J. P. Stigkær, A. Aillos, K. G. Nielsen, D. Mendes, C. Yigen and P. Molinari from Maersk Oil A/S, our colleagues P. Sørensen, A. Andreasen, B. Løhndorf, S. A. Meybodi and J. Biltoft from Ramboll Oil & Gas A/S, and H. Enevoldsen, M. Soltani, K. L. Jepsen and J. Hansen

from Aalborg University, for many valuable discussions and technical supports.

REFERENCES

- Denga, X., Li, G., Weia, Z., Yana, Z., and Yangb, W. (2011). Theoretical study of vertical slug flow measurement by data fusion from electromagnetic flowmeter and electrical resistance tomography. *Flow Measurement and Instrumentation*, 22, 272–278.
- Havre, K., Stornes, K.O., and Stray, H. (2000). Taming slug flow in pipelines.
- Hill, T.J. and Wood, D.G. (1994). Slug flow: Occurrence, consequences, and prediction. *University of Tulsa Centennial Petroleum Engineering Symposium*.
- Husveg, T., Rambeau, O., Drengstig, T., and Bilstad, T. (2007). Performance of a deoiling hydrocyclone during variable flow rates. *Minerals Engineering* 20, 368–379.
- Ismail, I., Gamio, J., Bukhari, S., and Yang, W. (2005). Tomography for multi-phase flow measurement in the oil industry. *Flow Measurement and Instrumentation*, 16, 145–155.
- Jahanshahi, E. (2013). *Control Solutions for Multiphase Flow - Linear and nonlinear approaches to anti-slug control*. Ph.D. thesis, Norwegian University of Science and Technology, The Faculty of Natural Sciences and Technology, Department of Chemical Engineering.
- Lukaszuk, S. (2004). A new concept of probability metric and its applications in approximation of scattered data sets. *Computational Mechanics*, 33(4), 299–304. doi: 10.1007/s00466-003-0532-2.
- Pedersen, S., Stampe, K., Pedersen, S.L., Durdevic, P., and Yang, Z. (2014). Experimental study of stable surfaces for anti-slug control in multi-phase flow. *International Conference on Automation & Computing, Cranfield University*, 20.
- Shepard, D. (1968). A two-dimensional interpolation function for irregularly-spaced data. *Proceedings of the 23rd ACM National Conference (ACM'68), New York, USA.*, 517–524.
- Williams, R., Jia, X., West, R., Wang, M., Cullivan, J., Bond, J., Faulks, I., Dyakowski, T., Wang, S., Climpson, N., Kostuch, J., and Payton, D. (1999). Industrial monitoring of hydrocyclone operation using electrical resistance tomography. *Minerals Engineering*, 12, 1245–1252.
- Xu, Y., Wang, H., Cui, Z., and Dong, F. (2009). Application of electrical resistance tomography for slug flow measurement in gas/liquid flow of horizontal pipe. *International Workshop on Imaging Systems and Techniques, Shenzhen, China*.
- Yang, Z., Pedersen, S., and Durdevic, P. (2014). Cleaning the produced water in offshore oil production by using plant-wide optimal control strategy. *MTS/IEEE OCEANS14, St. John's Conference*.
- Yang, Z., Stigkær, J.P., and Løhndorf, B. (2013). Plant-wide control for better de-oiling of produced water in offshore oil & gas production. *3rd IFAC International Conference on Intelligent Control and Automation Science*, 3, 45–50.