

THE EMBEDDED ELECTRONICS AND SOFTWARE OF DORIS OFFSHORE ROBOT [★]

Renan S. Freitas^{*} Marco F. S. Xaud^{*} Ighor Marcovistz^{*}
Alex F. Neves^{*} Rafael O. Faria^{*} Guilherme P. S. Carvalho^{*}
Liu Hsu^{*} Eduardo V. L. Nunes^{*} Alessandro J. Peixoto^{*}
Fernando Lizarralde^{*} Gustavo Freitas^{*} Ramon R. Costa^{*}
Pål From^{**} Mauricio Galassi^{***} Peter W. J. Derks^{****}
Anders Røyrvøy[†]

^{*} *Electrical Engineering Department, COPPE/Federal University of
Rio de Janeiro, Rio de Janeiro, Brazil*

^{**} *Mathematical Sciences and Technology Department, Norwegian
University of Life Sciences, Oslo, Norway*

^{***} *Research and Development Center, Petrobras/CENPES, Rio de
Janeiro, Brazil*

^{****} *TPD RDI Frontier Developments (FD), Statoil Brasil Óleo e Gás
Ltda., Rio de Janeiro, Brazil*

[†] *TPD RDI Mature Area Development and Increased Oil Recovery
(MADI), Statoil ASA, Bergen, Norway*

Abstract: DORIS is a mobile robot for remote supervision, diagnosis, and data acquisition on offshore facilities. The proposed system is composed of a rail-guided robot capable of carrying different sensors through the inspected area. This paper presents a general overview of the robot, and a description of the developed embedded electronics, power supply system and software architecture. The results with teleoperated navigation validate the concepts considered so far and rise several challenges for future works.

Keywords: mobile robots; field robotics; embedded electronics; robotic software architecture.

1. INTRODUCTION

The Oil & Gas (O&G) demand is expected to grow rapidly in the next decades (World-nuclear, 2012) and the need to obtain resources from hostile environments will increase operation costs. Also, working conditions on offshore installations, such as unfriendly atmosphere, heavy weather, extreme temperatures, and constrained space are serious obstacles for O&G companies. In order to be competitive, they are looking into new technologies to be able to produce marginal fields. The use of robotics in inspection, maintenance, and repair operations in O&G facilities could greatly improve efficiency, health and safety, while decreasing operational and logistics costs.

In the specific case of Brazil, the O&G industry is growing. The recent discoveries of big oil fields in the pre-salt layer of the Brazilian coast, located 300 km from the shore at depths of 5000-7000 m (Ferro and Teixeira, 2009), motivates the development of an offshore production system with high degree of automation.

Recent studies forecast a substantial decrease in the level of human operation and an increase in automation on future oil fields (Skourup and Pretlove, 2009). The studies also point out the potential increase in efficiency and productivity with robot operators, besides of the improvement in Health, Safety, and Environment (HSE) conditions, as robots can replace humans in tasks performed in unhealthy, hazardous, and confined areas (From, 2010).

The use of robotics in O&G industry represents great technological challenges to overcome the following aspects of offshore environments (Chen et al., 2014):

- i) *Atmospheric conditions* on offshore platforms are unfriendly, as hydrocarbon resources can generate explosive and toxic gases;
- ii) *Corrosive agents*: splashy salty water, salty air and corrosive chemicals;
- iii) *Weather* : high speed wind, rain, and hail. The relative humidity is up to 100% and ambient temperature can vary between -30°C to 50°C . Possibly highly radiant heat from equipment, and direct sunlight;
- iv) *Constrained space*: complex structures for robots such as pipes, flanges, tanks, and stairways.

Currently, the majority of the robotic systems in the O&G industry are used for subsea tasks, such as mapping of the seabed, and inspection and repair of underwater

^{*} This work is supported primarily by Petrobras S.A. and Statoil Brazil Oil & Gas Ltda under contract COPPETEC 0050.0079406.12.9 (ANP-Brazil R&D Program), and in part by the Brazilian research agencies CNPq and FAPERJ.

equipment, risers and pipelines. However, recent research has focused on robotic applications on the topside of oil platforms to perform inspection and maintenance tasks, which include valve and lever manipulation, gas level and leakage monitoring, acoustic anomalies diagnosis, and smoke and fire detection.

Some examples found in the literature are:

The MIMROex inspection robot (Bengel and Pfeiffer, 2007), developed by the Fraunhofer Institute of Manufacturing Engineering and Automation (IPA), is capable of safely navigating in offshore environments, and autonomously executing inspection tasks.

Sensabot (NREC/CMU, 2012), a teleoperated inspection robot developed by Carnegie Mellon University, was designed for severe weather and atmosphere, being certified to operate in toxic, flammable and explosive environments. The prototype was capable of safely operating on an on-shore facility, executing all its functionalities, including the level exchange through its cog rail elevation system.

The SINTEF Topside Robotic System is an intelligent instrumentation system designed to enable onshore operators to monitor and control the platform's processes (Kyrkjebø et al., 2009).

In this paper, we present a general overview of the DORIS robot, and a detailed description of the embedded electronics, power supply system and software architecture.

DORIS is an offshore inspection and monitoring robot being developed by COPPE/UFRJ in collaboration with Petrobras and Statoil. The robot moves through a rail carrying different sensors, processing sensor data *in loco* or storing it for future analysis. The sensors can identify abnormalities such as intruders in restricted areas, abandoned objects, smoke, fire, and liquid and gas leakages. The robot has an embedded manipulator, which enables machinery vibration diagnosis, instruments reading, and sample taking (Galassi et al., 2014).

2. GENERAL OVERVIEW

DORIS moves through a rail and both of them are based on a modular concept. Additional robot modules can be attached to include extra sensors, and the rail track can be modified by adding or replacing rail segments, thus enabling operation in different areas of the platform. Figure 1 illustrates the operation in a production plant.

The robot is controlled autonomously or by teleoperation. Task managing can be either in automatic (programmed using a mission interface) or manual mode (real-time remote operation). The teleoperation and monitoring capabilities guarantee online access to the embedded sensors, providing information of the surrounding environment and the robot operating conditions with real-time processing.

DORIS description can be split into five fields: mechanics, signal processing, electronics, power supply and software.

The *mechanics* comprises the robot modules, their coupling joints, and the rail. The mechanical design allows the robot to move smoothly in a 3D space and to make a full stop anywhere on the rail track. It incorporates the use of gimbals containing traction and guide wheels

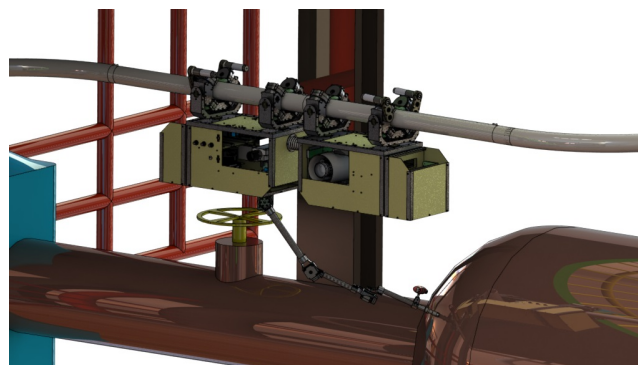

Fig. 1. Illustration of DORIS operation in a production plant.

which surround a tubular rail. Since the rail in an offshore facility may be as long as kilometers, it is designed to be as simple as possible to keep its cost to a minimum, while the design complexity is left to the robot. The use of two sets of gimbals provide mechanical compliance with rail curvatures, and smoothness of the robot's motion.

The robot is composed of two modules in default configuration, has an estimated total weight of 50 kg, and can reach a maximum speed of 1 m/s. In default configuration, the rail track forms a closed loop, and is made of straight and curved tubes.

DORIS has the following signal processing capabilities:

- i) *Video*: use of multiple cameras (visible-light, infrared, panoramic, and stereo) to detect video anomalies such as abandoned objects, smoke, fire, and fluid leakage;
- ii) *Audio*: detection of anomalies of impulsive nature, such as an explosion, and machinery diagnosis based on energy and pitch (fundamental frequency) signatures using a single or an array of microphones;
- iii) *Vibration analysis*: use of accelerometers to diagnose the operation mode of rotating machines, performing possible fault classification, such as misalignment and unbalancing operation;
- iv) *Gas sensor*: identification of gas level and leakages;
- v) *Mapping*: environment 3D model with a laser scanner.

The main idea of all these signal processing features is to make the robot perform an initial reference round on the closed rail track, being manually validated by a system operator. In the subsequent rounds, all signal processing algorithms compare the newly acquired signals with the reference data to detect any form of anomaly, as indicated above. Once an anomalous behavior is detected, an alarm is flagged to the system, which stores all associated data for immediate or future diagnosis.

A detailed presentation of the mechanical and signal processing systems of DORIS can be found in Carvalho et al. (2013) and Galassi et al. (2014).

Considering the robot functionalities and the aggressive offshore environment, several challenges should be addressed. Regarding the robustness and safety required to operate in classified areas, the robot must be: sealed against water and particles, resistant to a wide temperature range, protected from impact and vibration, electrically shielded to avoid explosion by ignition, and equipped

with a monitoring system. Another concern is that the embedded computers must run heavy signal processing algorithms, requiring high computational power. On the other hand, the power supply system must efficiently provide power and maintain a low level of power consumption.

3. EMBEDDED ELECTRONICS

The embedded electronics (EE) is composed of a local central computer, a remote operation base and the following subsystems: communication, actuation, data acquisition, and vehicle support system (VSS). The embedded computer is the robot decision center, and it is in charge of: heavy data processing, data storing, data management, control of the actuation system, and teleoperation.

The computer is composed of a high performance Intel®Core™i7 microprocessor embedded in a PCIe/104 form factor board, RAM cards and an SSD (*solid-state drive*) card. The use of these components enables an easy expansion of the system.

The *remote base* is the user workstation in the offshore facility through where DORIS can be teleoperated. It is composed of a radio joystick, a Wi-Fi access point and a computer system with a graphical user interface (GUI).

The *communication system* comprises the data traffic within the robot, and between the robot and the remote base. This system is composed of:

- i) *Local Gigabit Ethernet* network for heavy data real-time traffic within the robot, such as video, audio and commands from/to the computer;
- ii) *Controller Area Network (CAN)* bus for control commands to the actuation system;
- iii) *Wireless technologies*: DORIS can be remotely operated via Wi-Fi IEEE 802.11n or via 2.4/5.0 GHz radio joystick, upon Wi-Fi absence or failure.

The Ethernet network has a star topology centralized by an OSI-Layer 2 Switch, and connects the computer, Ethernet peripheral devices (such as cameras), a local WiFi access point and the vehicle support system (VSS). This network topology allows easy expansion of the Ethernet network for additional robot modules.

The *actuation system* comprises the CAN bus and the *traction subsystem*, which is composed of four controller drivers (Maxon EPOS2 70/10) and four motor packs, each containing a high power 200 W EC-4-pole Maxon brushless motor, an encoder and a high power planetary gearhead with 21:1 ratio. DORIS traction is commanded via CAN bus (computer to drivers), which provides reliability and appropriate speed to this application (Corrigan, 2008). The interface between the computer and the CAN bus is a PCI/104-Express board with a galvanic opto-isolator to minimize interference on the rest of the EE system, since the motors generate significant conductive noise.

The *data acquisition system* system collects image, video, and audio data from the environment. It is composed of a fixed camera, an infrared thermal camera for thermal map and temperature measurement, a *fisheye* camera, two stereoscopic webcams (with embedded microphone), and an USB Inertial Measurement Unit (IMU).

An overall scheme of DORIS EE system is shown in Fig. 2.

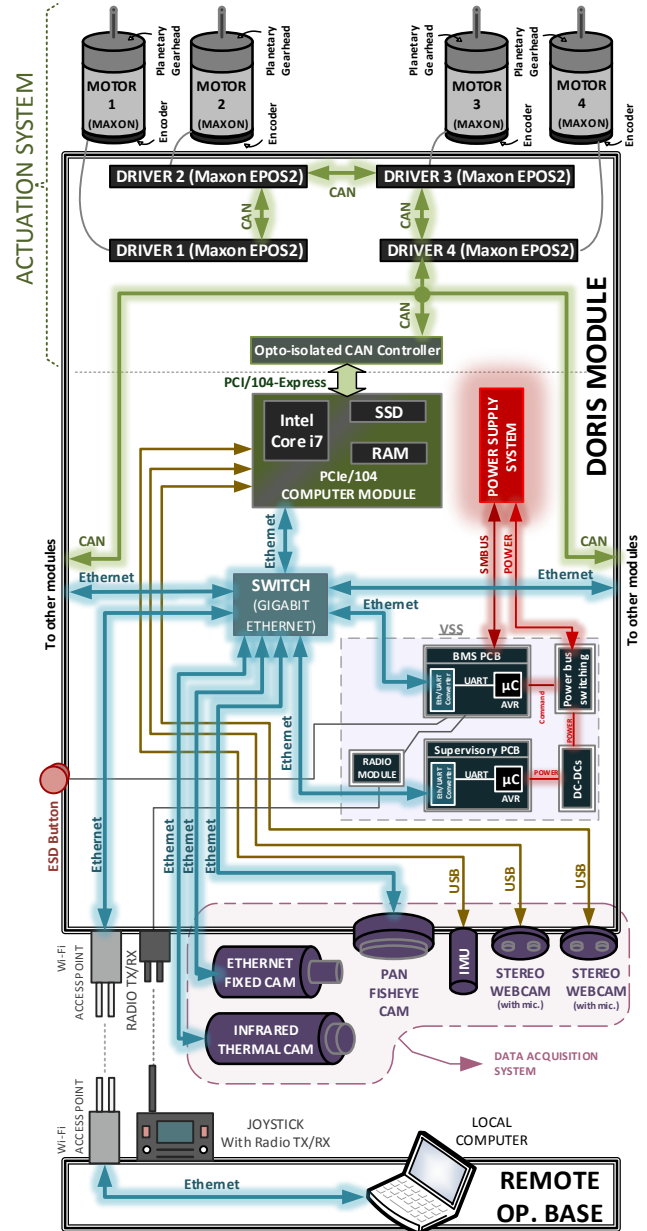

Fig. 2. Overall scheme of DORIS EE system.

3.1 Vehicle Support System

The *Vehicle Support System (VSS)* (Oliveira et al., 1998) is composed of microcontroller based *printed circuit boards* (PCBs) designed for:

- i) *Failure detection* achieved by the monitoring of devices' current/voltage and module temperature and humidity;
- ii) *Devices protection* Devices protection against overcurrent by fuses and solid-state relays;
- iii) *Energy distribution and monitoring*;
- iv) *Emergency handling* Emergency handling: the robot can be turned on/off using a physical *emergency shutdown (ESD)* button or via radio.

DORIS VSS is part of EE hardware (Fig. 2), and includes three types of PCBs: Supervisory, Battery Management System (BMS) and Power Bus Switching (PBS).

The *Supervisory* is composed of an ATMEL AVR AT90CAN64 microcontroller and several sensors. Its main monitoring functionalities are to read: supply currents of peripheral devices (hall-effect sensors and a 16-ch Analog to Digital Converter (ADC)); the module's temperature/humidity (I2C SHT71 sensor); and the supply voltages (AVR embedded ADC). The AVR manages the collected data, reports them periodically to DORIS computer via Ethernet, and locally detects or reacts to faulty situations. Since Ethernet is not an available interface in this AVR model, an UART-to-Ethernet converter is used. The local fault detection is done by AVR pre-programmed algorithms, which react to protect devices against overcurrent/overvoltage by commanding the open/close state of solid-state relays, hence turning off the devices. All these AVR functionalities can also be commanded by the remote operator.

The *BMS* is in charge of managing the power supply system. It communicates with the batteries via *System Management Bus* (SMBUS) and has a connection with the *PBS*. SMBUS is the interface of the telemetry system embedded in DORIS batteries. This system collects important information from the batteries, such as temperature, voltage, current and state of charge. The BMS PCB periodically reports all data to DORIS computer via Ethernet with the UART-to-Ethernet converter.

The *PBS* contains high power solid-state relays (20 A), which can be commanded from the *BMS* to distribute the power of each battery pack. The decisions about the best power balancing are based primarily on data collected via SMBUS.

4. POWER SUPPLY SYSTEM

The power supply system is responsible for the safe, reliable, and efficient electric power distribution for DORIS devices. The electric power is supplied by high energy density military lithium ion batteries, which come with an intrinsic safety circuit for protection against short-circuits and heating. Each battery pack has a capacity of 10 Ah when delivering 24 Vdc. According to mechanical constraints, each DORIS module admits a maximum of four battery packs, weighing 1.4 kg each.

In order to avoid electromagnetic interference and conductive noise interference caused by the robot motors, the system works with two separate power buses, each one using two 24 Vdc/20 Ah batteries connected in parallel. One bus is dedicated to power the motors and the other to power all the electronic devices.

DC-DC converters are employed to create different and stable voltage levels: 24 , 12 and 5 Vdc. To improve power supply protection, fuses protect the system from undesired peaks, and buttons allow power buses to be separately turned on/off.

Since DC batteries are the power source of the robot, there is no need of capacitors to correct delays between current and voltage. However, a capacitor bank would allow additional energy to the motors. The capacitor bank must have at least 400 to 500 $\mu F/A$ (Tecnadyne, 2006).

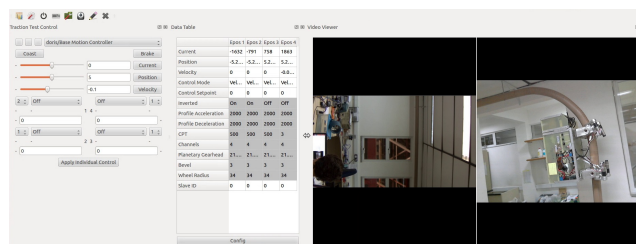

Fig. 3. Robot GUI.

In the case of DORIS, as each motor may require a peak current of 20 A, a capacitor bank dedicated for each driver would need between 8000 and 10000 μF , 36 V (maximum operating voltage). Also, the capacitors should have low equivalent series resistance and should be located as close as possible to the noise source, namely the motors.

The batteries are connected to the *PBS*, which has solid state relays able to link each battery to any of the two power buses and diodes to avoid back flow current for safety. This is done by switching both the positive and the negative poles of a battery into a power bus simultaneously. The *PBS* logic is implemented on the *BMS*, responsible for commanding the relays in order to guarantee a safe and robust operation.

5. SOFTWARE ARCHITECTURE

The software architecture allows the implementation of high and low level control of the robot. It considers two important factors: tools are open-source and provide modular functionalities. These requirements led to the adoption of Qt as the graphical interface framework (Qt-Project, 2014), Robot Operating System (ROS) as the communication middleware (Quigley et al., 2009), and Linux/Ubuntu as the operating system.

The software provides autonomous control (programmed tasks) and remote control through a GUI in the Host Control Base (HCB) computer. In both computers (robot and HCB), a set of processes, denominated *ROS nodes*, runs in parallel and can communicate with each other.

To deal with this specification, a software framework that works over the ROS environment is proposed, named *Robot Package Software*. It is based on *Tools* (graphical windows) and *Components* (processing and communication units) grouped into *Robot Packages* (which are dynamic libraries), and also the *ROS node Robot GUI* (that can load those *Robot Packages* on run-time). The *Components* that deal with hardware should run on the robot's embedded PC, while others that interact with Tools should run on the HCB. Components communicate with each other through ROS, thus allowing the HCB to view and control the robot. Fig. 3 shows the robot control through the Robot GUI.

Robot Packages can be derived from other *Robot Packages*, so that *Components* and *Tools* from the derived package can interact with the ones on the base package. Two *Robot Packages* have been defined: the *General Package* and the *DORIS Package*, derived from the first. The *General Package* contains generic *Components* and *Tools* related to video, audio, data table, gamepad, and devices configuration that can be used on other robotic systems. The *DORIS Package* is more specific to DORIS and deals

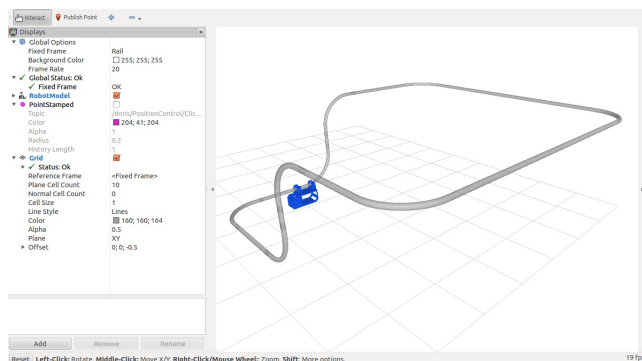

Fig. 4. Robot system 3D model.

with its hardware and functionalities: it has just one *Tool* to control the 4 motors; and *Components* acquire video from an IP camera, interface with the CAN bus to control the motors, and communicate with the PCB boards through a serial bus.

Within the ROS framework, any message can be logged during the robot operation, including audio, video, sensors, control and motors data. The logs recording and playback can be performed via ROS commands (rosviz). The data being played can be accessed in the *Robot GUI*.

A robot 3D model based on ROS *Unified Robot Description Format* (URDF, a XML format to represent a robot model) is presented in Fig. 4. The 3D model, which includes the rail and the robot system, is integrated in the GUI and can be visualized using RVIZ (a ROS tool). The robot motion can be controlled (via a desired setpoint) by the operator using the 3D model while visualizing the robot position in the GUI.

6. EXPERIMENTAL TESTS AND RESULTS

A prototype named *Single Autonomous Module* (SAM) was built to verify the proposed concepts. In addition, some VSS functionalities were individually tested, but not yet fully integrated with SAM. Subsections 6.1 and 6.2 below detail the executed tests.

6.1 Single Autonomous Module (SAM)

SAM (Fig. 5) is a single module composed of an AXIS ethernet fixed camera, two USB Minoru stereoscopic Webcams, an IMU, a Cisco wireless router, four Maxon motor packs and Maxon EPOS2 drivers, a PCIe/104 with Intel Core i7 computer module, 4GB DDR3 RAM, 240GB SSD (Kingston), and a dual-channel opto-isolated PCI-express CAN interface.

SAM was tested in horizontal and vertical motion on a closed rail made of straight and curved PVC tubes. The curved segments are straight tubes of 1 m bent by 90°, resulting in a curvature of approximately 630 mm. The complete closed track has 23 m length and comprises all the possible robot motion capabilities. The rail was installed in the GSCAR laboratory, in COPPE/UFRJ (Brazil), and SAM was able to fully move throughout the entire track.

SAM's electronics power bus uses 14 AWG wires (up to 15 A), and the motors power bus uses 12 AWG wires (up



Fig. 5. SAM - Single Autonomous Module.

to 21 A). The *PBS* was not yet implemented, thus diodes were welded on the positive pole of each battery and then this pair of cables was connected to a screw block linking the positive poles on a specific bus. The same was done with the negative poles in another area of the screw block, creating a parallel connection. After the screw block, a 20 A cable is connected to the input of the DC-DC converters, and their output is delivered to the corresponding device.

Concerning electronics, power supply, and software, the first objectives of SAM were to test the following concepts:

- i) *Electronics*: sensor integration and communication system;
- ii) *Power supply*: independent buses for motors and electronics devices, batteries robustness, and autonomy;
- iii) *Software*: teleoperation and user interface.

The communication system was implemented as follows: an *Ethernet communication network* to connect the fixed camera, the computer, and the access point; a *Wi-Fi communication network* to connect SAM with the operation base; a *CAN bus* to control the actuators; and two stereoscopic Webcams and an IMU were plugged to the computer through USB connections. The robot operation range is limited to the Wi-Fi antenna, thus, to improve it, Wi-Fi repeaters and intrinsic safe barriers should be installed. To ensure data loss prevention, all data is firstly stored and processed locally, and then transmitted.

The concept of independent power buses proved to be efficient, and the designed battery capacity could handle the system energy demand. The robot autonomy was greater than five hours, but this will highly depend on the embedded devices, the required task, and the rail track. It was observed that when SAM moves downwards, the motors control brake the robot, generating a brake energy on the way back to the source. Depending on the length of the downhill section, and on the robot's speed, this energy may reach a voltage level that causes the motors drivers to reset.

Furthermore, SAM has already been teleoperated by Petrobras (from Brazil) and by Statoil (from Norway) using a ROS web bridge. The robot performed position and velocity tracking tasks and the video camera frames were sent from Brazil and received in Norway with a two seconds delay. As the main goal of DORIS is to have autonomous capabilities and to be operated locally in the

offshore platform, delays due to distance should not be of major concern.

6.2 Vehicle Support System (VSS) Tests

All DORIS VSS functions were successfully tested independently. The following tests/implementations were successfully performed:

- i) Logic to command the *solid-state relays* to turn some devices on/off;
- ii) Acquisition of *module voltages* and *module currents*: DC-DC voltage (5, 12 and 24 Vdc), battery raw voltage measurements, and the currents that supply each device;
- iii) Acquisition of *module temperature/humidity*;
- iv) Acquisition of *battery information* through SMBUS: voltage, temperature, current, state of charge, and battery status;
- v) *Timers* to enable robot shutdown in predetermined time, and periodic data report of voltages, currents, relays status, temperature and humidity;
- vi) *Ethernet Communication*: all data can be accessed via Ethernet.

7. CONCLUSION AND FUTURE WORK

In this paper, we presented the EE, power supply, and software architecture of the DORIS project, which endeavors to develop an offshore facilities inspection and monitoring robot. All the mobile offshore robots seen so far are wheeled robots, which enables great flexibility and a large inspection area. However, they have to deal with complex problems compounded by the offshore platform environment, such as autonomous navigation, mobility, and collision avoidance. DORIS moves through a rail as a tradeoff between constrained mobility and alleviation of the above issues. It has onboard electronics with multiple fail safes, power management, and a state of the art vehicle support system.

A prototype, SAM, was built to test the electronics, power supply, and software architecture concepts. Preliminary results show good overall performance of sensor integration and communication, independent power buses for electronics and motors, and teleoperation.

The Vehicle Support System was tested in a simple testing platform, and the customized PCBs were able to monitor temperature/humidity, DC-DC voltage levels, the devices' currents, and batteries data via SMBUS.

Ongoing implementations and future work include:

- i) *New VSS tests*: implementation of the BMS logic that uses the SMBUS data to manage power distribution;
- ii) *Autonomous operation*: advanced localization, mapping, and mission control;
- iii) *Reduced interferences*: an electrostatic discharger should be designed to drain the accumulated charge from the shielding system;
- iv) *Solution for DORIS downhill motion issue*: Tests will be held to measure the generated amount of power to decide if it is worth to store or waste it;
- v) *Hardware Certification*: DORIS must be certified to operate in harsh and explosive environments.

REFERENCES

- Bengel, M. and Pfeiffer, K. (2007). Mimroex mobile maintenance and inspection robot for process plants. *Fraunhofer Institute for Manufacturing Engineering and Automation IPA*, pp. 1–2.
- Carvalho, G., Freitas, G., Costa, R., Carvalho, G., Oliveira, J., Netto, S., Silva, E., Xaud, M., Hsu, L., Motta-Ribeiro, G., Neves, A., Lizarralde, F., Marcovitz, I., Peixoto, A., Nunes, E., From, P., Galassi, M., and Røyrvåg, A. (2013). Doris - monitoring robot for offshore facilities. *Offshore Technology Conference Brasil*.
- Chen, H., Stavinoha, S., Walker, M., Zhang, B., and Fuhlbrigge, T. (2014). Opportunities and challenges of robotics and automation in offshore oil & gas industry. *Intelligent Control and Automation*.
- Corrigan, S. (2008). Introduction to the controller area network (CAN). Texas Instrument Application Report SLOA101A. <http://www.ti.com/lit/an/sloa101a/sloa101a.pdf> Accessed on October 20th, 2014.
- Ferro, F. and Teixeira, P. (2009). Os desafios do pré-sal. Câmara dos Deputados, Edições Câmara. <http://www2.camara.leg.br/a-camara/altosestudos/pdf/Livro-pre-sal.pdf> Accessed on October 20th, 2014.
- From, P. (2010). *Off-Shore Robotics: Robust and Optimal Solutions for Autonomous Operation*. Ph.D. thesis, Norwegian University of Science and Technology.
- Galassi, M., Røyrvåg, A., Carvalho, G., Freitas, G., From, P.J., Costa, R.R., Lizarralde, F., Hsu, L., de Carvalho, G.H., de Oliveira, J.F., et al. (2014). Doris - a mobile robot for inspection and monitoring of offshore facilities. *Anais do XX Congresso Brasileiro de Automática*.
- Kyrkjebø, E., Liljebäck, P., and Transeth, A. (2009). A robotic concept for remote inspection and maintenance on oil platforms. In *Proceedings of International Conference on Ocean, Offshore and Arctic Engineering*.
- NREC/CMU (2012). Sensabot: A safe and cost-effective inspection solution. *Journal of Petroleum Technology*, pp. 32–34.
- Oliveira, P., Pascoal, A., Silva, V., and Silvestre, C. (1998). Mission control of the marius autonomous underwater vehicle: system design, implementation and sea trials. *International Journal of Systems Science*, 29(10), 1065–1080.
- Qt-Project (2014). Qt online documentation. <http://qt-project.org/> Accessed on October 20th, 2014.
- Quigley, M., Conley, K., Gerkey, B., Faust, J., Foote, T., Leibs, J., Wheeler, R., and Ng, A. (2009). ROS: an open-source robot operating system. In *Proceedings of International Conference on Robotics and Automation, ser. Open-Source Software Workshop*.
- Skourup, C. and Pretlove, J. (2009). The robotized field operator. *ABB Review*, (1), 68–73.
- Tecnadyne (2006). General power system wiring practices applied to tecnadyne dc brushless motors. Tecnadyne Application Note AN601. http://www.tecnadyne.com/cms/images/products/pdf/AN601_Back_EMF_Ground_Loops.pdf Accessed on October 20th, 2014.
- World-nuclear (2012). Uranium, electricity and climate change. World Nuclear Association website. <http://www.world-nuclear.org/info/Energy-and-Environment/Uranium-Electricity-and-Climate-Change> Accessed on October 20th, 2014.