

Advanced Anti-slug Control for Offshore Production Plants

Campos, M.¹, Takahashi, T.², Ashikawa, F.³, Simões, S.⁴, Stender, A.⁵, Meien, O.⁶

Petrobras, Research Center - CENPES, UO-RIO, UO-BS, Brazil, (e-mail: ¹mariocampos@petrobras.com.br, ²thiogotakahashi@petrobras.com.br, ³fabio_ashikawa@petrobras.com.br, ⁴saulsimoes@petrobras.com.br, ⁵alberto.santanna@petrobras.com.br ⁶meienov@petrobras.com.br,)

Abstract: The application of advanced control techniques in offshore oil production plants is a challenge. There are many changes in operational points in time, for example, the process is affected by the natural oil well's behavior dynamics. Besides that, limited instrumentation available has to be considered when thinking in oil optimization and control. In order to improve the scenario, tailor-made advanced control modules have been developed for those units. The present article will present development, implementation and results of anti-slug control for three platforms located at Campos and Santos basins. The controllers were designed to achieve improvement in operational stability and safety, decreasing in unscheduled compressor shutdown events, as well as increasing in operational efficiency.

Keywords: slug control, advanced control, offshore platform's automation, industrial control and results.

1 INTRODUCTION

Severe slugging is a common problem in many offshore platforms, because production facilities cannot handle the large flow and pressure variations due to slugging. As a consequence, unstable flow results in poor separation that may cause damage to critical equipment like heat exchangers, increases maintenance costs, and may also cause unscheduled shutdowns due to unstable multiphase flow. So, high pressure trips in compressors or high level trips in separators are able to generate substantial economic losses. There are many different mechanisms which cause unstable flow, or slugs, depending on flowline geometry, fluid distribution among phases and equipment. Slugging most common causes are due to irregularity in the sea bed terrain, vertical pipeline sections, instability in gas-lift flow, differences in gas/liquid velocities, etc. A description of slug mechanisms can be found in Pickering et al. (2001), Hu (2004), Sinegre (2006) and Kaasa et al. (2007).

The traditional method of minimizing slugs is manually choking flow at the expenses of production decreasing, increasing gas-lift flow, and subsea chemical injection, both leading to costs increasing. Another option is to use automatic control to reduce or even eliminate oscillations, without production loss, manipulating the choke valve (Storkaas, 2005) (Storkaas and Skogestad, 2007). Therefore, it is important to continue developing new control strategies which result in attenuation or protection against severe slugging.

In practice, there is some resistance by operators in using new automatic control, particularly anti-slug control, due to the belief of keeping choke valve fully open will result always in production improvement. Which is true for wells with no slug

pattern, however may cause production losses in wells with slugging flow (Hu, 2004).

According to the American Petroleum Institute, advanced control is defined as any control strategy that has functions beyond those commonly associated with regulatory control. In this paper, it is discussed an advanced anti-slug control strategy, which can be thought as an expert system with three modules: slug diagnostic, anti-slug control algorithm, with auto-tuning capabilities, and severe slugging protection. This system was implemented on a process computer that communicates with the platform's automation system.

Although advanced control systems are reality in many industrial areas like refineries, petrochemicals and gas plants (Campos et al., 2009), they are not widely used for offshore production units (Campos et al., 2013). Many reasons can be pointed as causes for such behavior: no advanced control specialist onboard, more transients and disturbances due to oil well behavior, uncertainties and noise, non-linear and time-varying process, lack of instrumentation, etc.

Due to these problems, linear and multivariable predictive advanced controllers, common in other areas such as refineries and petrochemicals are difficult to apply in platforms' process. Thus, different advanced control strategies were proposed and applied to offshore platforms. The problem was divided in small and less complex problems. Each one has an expert system to deal with. One of the goals was to develop anti-slug control for wells, which will be the focus of this paper. This system has a control algorithm, with some degree of adaptation for each different operational condition, and also has some modules to diagnose and protect process equipment. The advanced controller was developed and implemented in three offshore platforms and

the results will be shown in the following discussion. The implementations of anti-slugs advanced control strategies bring the following benefits:

- Reduction in production losses due to unplanned shutdowns.
- Increasing stability and profitability.
- Increasing safety and operating reliability.
- Increased sustainability by minimizing flaring.

In this article, we will present some details about advanced anti-slugging control strategy, results and economic gains obtained with its implementation in oil production platforms.

2 SLUGS PROBLEM DESCRIPTION

A scheme of unstable multiphase flow cyclic behavior is shown in Figure 1. This is an example of severe slugging caused by pipeline-riser systems with low points in front of the riser, where “slugs” of liquid accumulate before pushed upwards by gas. In the first sub-figure, liquid blocks the low point of the riser preventing gas flow. Liquid falls back from the riser by gravity and causes the slug to grow and fill the riser. The pressure in the pipeline steadily increases due to the inlet flow of gas until it is large enough to push the liquid slug out of the riser causing a great disturbance to downstream separators. When the tail of the liquid slug enters the riser, downhole pressure drops due to the reduced static head of the liquid column which causes the gas to expand. When gas leaves the riser, a large disturbance is generated to compressors pressure and anti-surge controllers. After that, velocities in the riser become too low to carry liquid up the riser and process starts again with liquid accumulation, fall-back, in lower points.

Slugs represent a major challenge to downstream processing facilities due to large variations in flow and pressure. As pointed before, the possible consequences are: unscheduled shutdowns, damage to topside equipment, production decreasing, resulting in substantial economic losses and increase in maintenance costs.

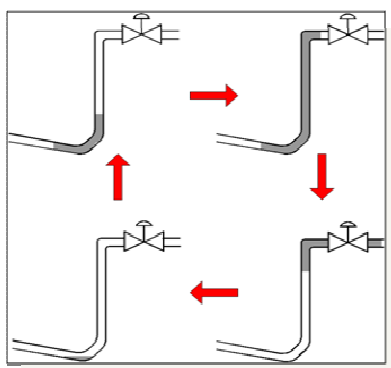

Fig. 1. Slug cycles.

One way to eliminate slugs is manually choking flow until reach stability; however this method has the drawback of production loss. Another option is the use of automatic control to reduce, or even eliminate, oscillations. In figure 2,

it is shown the oscillating behavior of the downhole pressure (PDG - Permanent Downhole Gauge) of a slugging well. There is a maximum valve opening which enables stable operation when no control is applied. If we try to operate above bifurcation point unstable multiphase flow occurs characterized by the stable limit cycle where downhole pressure oscillates between high and low pressure values. The upper red line of the figure 2 shows the maximum pressure at a particular valve opening and the red lower line the minimum pressure. The dashed line in the middle shows the unstable steady-state solution, which is the desired operating point in closed-loop operation.

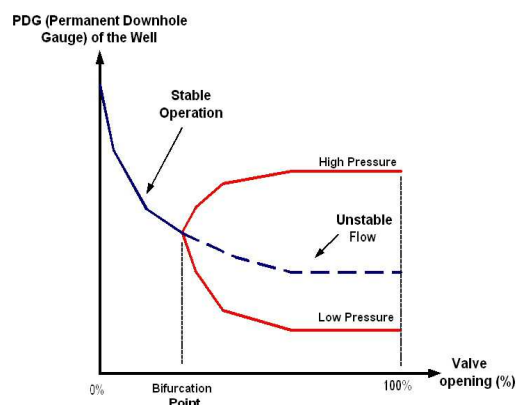

Fig. 2. Bifurcation plot (red line shows the limit cycle).

3 ANTI-SLUG ADVANCED CONTROL

The proposed advanced anti-slug control has three main modules, as shown if figure 3:

- Diagnostic Module – responsible for detecting severe slugs based on pressure measurements.
- Anti-slug Protection Module – responsible for preventing propagation of severe slugs to topside equipment (separators and compressor).
- Anti-slug Control Module – responsible for minimizing or even eliminating slugs. If possible, keeping choke valve at the desired position.

Following these modules will be described.

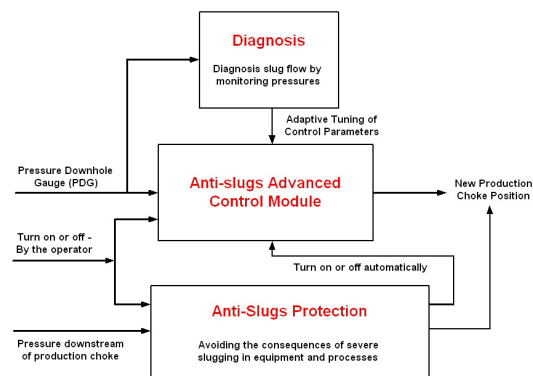

Fig. 3. Block diagram of the Anti-slug Advanced Control.

3.1 Diagnostic Module

This module tries to detect oscillations in the available pressure gauges: downhole pressure (PDG), wet Christmas tree pressure (TPT - Temperature and Pressure Transducer) and upstream choke pressure. Pressure is considered to be oscillating if the difference between maximum and minimum values within a time window is above a fixed control parameter. This information will be used by the anti-slug control module, to adjust its tuning parameters, and by the protection module.

3.2 Anti-Slug Protection Module

The Anti-slug Protection Module is designed to prevent the propagation of severe disturbances to topside equipment. If there is measurement of pressure downstream choke, this value is used and compared with a maximum desired parameter. If there is only pressure measurement upstream choke, we have to infer the maximum pressure allowed downstream for a particular choke valve position, as shown in figure 4. We use historical process data, which has great variability, to obtain or tune this curve in order to protect equipment (red line in the figure 4).

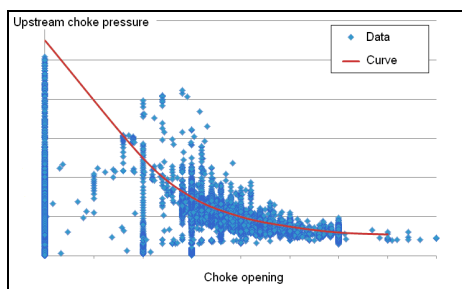

Fig. 4. Protection curved - Upstream choke pressure as a function of the choke opening (%).

Based on the inferred curve, the protection algorithm determines the maximum pressure value. If measured pressure remains above this threshold during a certain number of control cycles, choke is closed to a minimum value defined in the operators interface. The protection algorithm will maintain the choke valve at its minimum value while it detects severe slugs. When pressure becomes stable and below the maximum value, system allows the anti-slug control module to open again the choke valve.

3.3 Anti-slugs Control Module

The most common anti-slug control strategy uses downhole pressure as controlled variable of a PID algorithm and the choke opening as the manipulated variable (Dalsmo et al., 2002), (Storkaas et al., 2003), (Godhavn et al., 2005), (Stasiak et al., 2012). The objective is to eliminate or at least to minimize slug disturbances to the process. However, in practice many wells can lose their downhole measurements due to problems in the sensor or in the communications cables. Therefore, it was necessary to develop new algorithms using only topside pressure. We will describe

briefly some algorithms that are available for being chosen for a specific application in a platform.

3.3.1 ONFC (On-line Neuro-Fuzzy Controller) Algorithm

The ONFC algorithm (Gouvêa, 2005), (Carvalho, 2010), (Carvalho et al., 2010) is used instead of the PID controller because it can deal with nonlinear process and it has adaptive characteristics. The setpoint of the ONFC is defined by another controller that tries to find out the downhole pressure which results in a desired choke position defined by operator. Figure 5 shows the block diagram of this algorithm.

In this ONFC algorithm the controller output (u) is obtained by error's membership functions and some tuning parameters (w - weights), which were adapted depending on the error.

$$u = \mu_1 w_1 + \mu_2 w_2 \quad \text{and} \quad e = SP - Y$$

$$w_i(k) = w_i(k-1) - \alpha \frac{\partial e(k)}{\partial w_i} \quad i = 1, 2$$

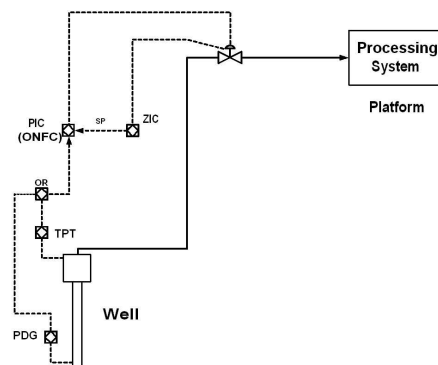

Fig. 5. Flowchart of the ONFC Algorithm.

3.3.2 Three (3) PIDs Algorithm

This algorithm is based on three PIDs controllers that compete with each other in override strategy to handle the choke opening. The controlled variables are: PDG or TPT, upstream and downstream choke pressures. This logic, like the ONFC algorithm, also depends on the right choice of the setpoint for each pressure controllers. Figure 6 shows a flowchart of this algorithm.

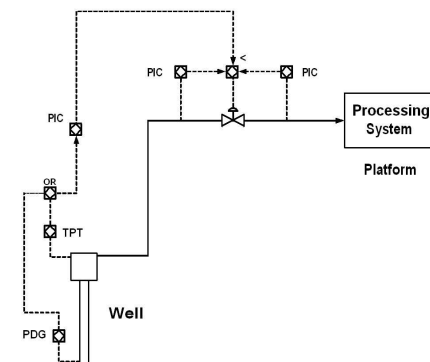

Fig. 6. Flowchart of the 3 PIDs Algorithm.

3.3.3 Gamma Algorithm

In order to avoid the problem of defining the right pressure setpoint for each operating condition, it was developed a Gamma algorithm, which is based on work published by Stasiak, Pagano and Plucenio (2012). The control purpose is to suppress slug oscillations ensuring stable system operation and, at the same time, to keep the control at a desired choke position value. Gamma algorithm uses the choke valve opening as the output variable, instead of pressure setpoint as in Stasiak et al. (2012). The control law is given by:

$$\Delta U_{k+1} = \gamma_1 \times \Delta PDG_k + \gamma_2 \times \Delta PDG_{k-1} + \beta \times (SP_{CHOKE} - U_k)$$

where SP is the desired choke operating point (U) and the parameters γ are tuning values to obtain a desired anti-slug performance (stabilizing action), and β is another tuning parameter that adjusts how fast the control action reaches the desired operating setpoint. The tuning of these parameters should take into consideration that the stabilization process pressure is a priority. This algorithm can be used to control any of the following variables: downhole pressure (PDG or TPT), upstream choke pressure or downstream choke pressure.

3.3.4 Period Algorithm

The goal of this algorithm is to identify the characteristics of the slugs (period and amplitude) in order to predict future slugs and close or open the choke valve at the right moment. This algorithm was developed to use downhole pressure, or upstream choke pressure. Figure 7 shows a schematic of this period algorithm.

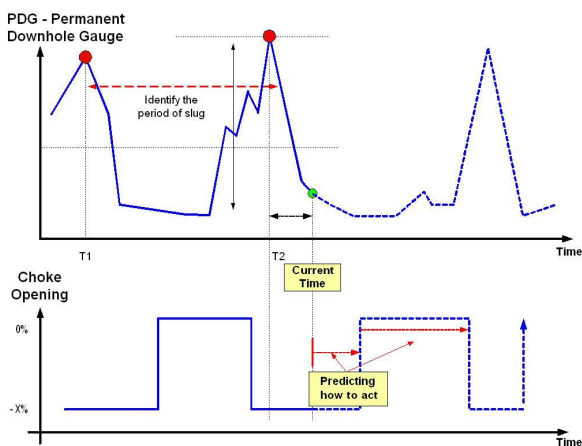

Fig. 7. Period algorithm actuation.

4 ANTI-SLUG CONTROL IMPLEMENTATION

The algorithms presented in this paper were implemented in the MPA environment (Module of Automated Procedures), which is a tool developed by Petrobras and PUC University to implement advanced automation and control strategies. Figure 8 shows part of the anti-slug advanced control

implementation in the MPA software. The controller is executed every 10 seconds. This tool uses a flowchart language that is easy to implement and to maintain the control rules. MPA runs in a process computer and communicates with the platform's automation system through a driver or an OPC protocol.

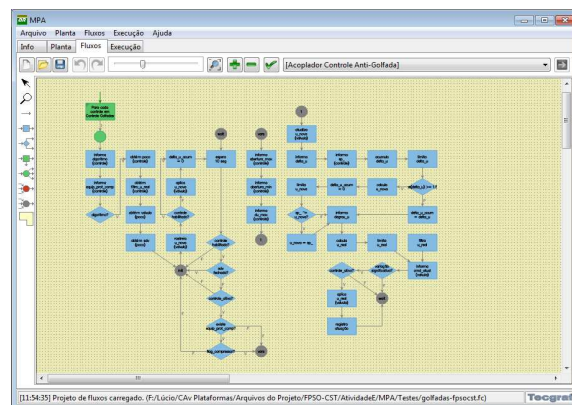

Fig. 8. Example implementation of the MPA

5 RESULTS AND ECONOMIC GAINS

This anti-slug advanced control was implemented in three offshore oil production platforms. In one platform, due to the limitation of the choke valve actuator, it was used only the anti-slug protection module. In the Anti-slugs Control Module, the Gamma Algorithm was chosen for the implementation in the platforms, because it was easier to tune and does not require setpoints. For some wells, we use the PDG as process variable, but there were other wells where this information was not available. As a consequence, pressure upstream choke was used as input for anti-slug controller with acceptable performance.

Table 1 shows the performance of the controller for three platforms. It can be seen that the system was able to reduce the time that pressure downstream choke was larger than maximum limit for all platforms. This is related with the performance of protection module, showing that this control system increased the operational safety.

Table 1. Time (%) with header pressure above a limit.

	Before	After	Reduction
Platform A	0,65	0,05	-92%
Platform B	0,09	0,02	-78%
Platform C	1,92	1,25	-35%

Figure 9 shows an example of operation of the anti-slug advanced control for one well (with protection and control algorithm). As we can see, there was a decrease in variation amplitude of upstream choke pressure (green line) when the anti-slug control was manipulating choke opening (controller in automatic mode). The yellow line in this figure is the pressure of the oil separator.

Table 2 quantifies the reductions in the amplitude and the average value of the subsea pressure (TPT) for one well. There was an increase in operational stability due to the decrease in TPT pressure amplitude and increase in production due to the reduction of its average value.



Fig. 9. Performance of the anti-slug control for one well.

Table 2. Effect on TPT due to Anti-slug Advanced Control

	Before	After	Reduction
Range of Variation	200 psi	180 psi	-22 %
Average	541 psi	528 psi	-2 %

Figure 10 shows the performance of the Anti-slug Advanced Control for another platform. After the implementation of the controller for all wells, the number of unscheduled shutdowns (trips) of the compressor has been decreased from an average of six to around 0.8 trips per month. As a consequence, gas flaring (Nm^3/month) associated to compressor trip events were reduced substantially, as shown in figure 11. These results show that anti-slug advanced control has a positive impact on energy efficiency and the process sustainability, with emission reduction of 1200 ton CO_2 per year by the platform. The economic gain, avoiding gas flaring was estimated around US\$ 300.000,00 per year for this unit.

Figures 10 and 11 also show that the advanced control was able to reduce significantly the variability of the number of shutdowns and the gas flaring, helping to increase safety and operational planning and predictability.

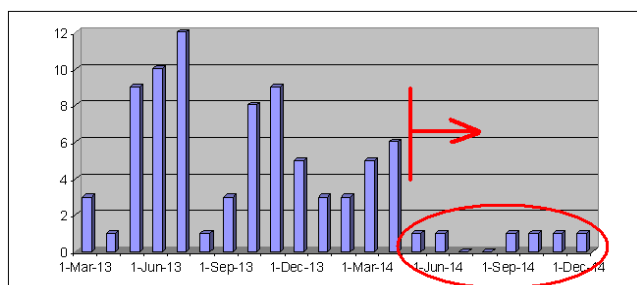

Fig. 10. Compressor trip reduction with anti-slug control.

A key point for success of any advanced control strategy is an effective participation of operators during design, commissioning and operation, in order to receive feedbacks

which help to improve controller's performance. It was observed that during implementations described in this paper the involvement of operators were essential to change operational culture and for the success of the project. Figure 12 shows that the anti-slug advanced control has been used, in long term, more than 80% of the operating time, after commissioning. Operators only turn off the control during specific events as pigging pipelines.

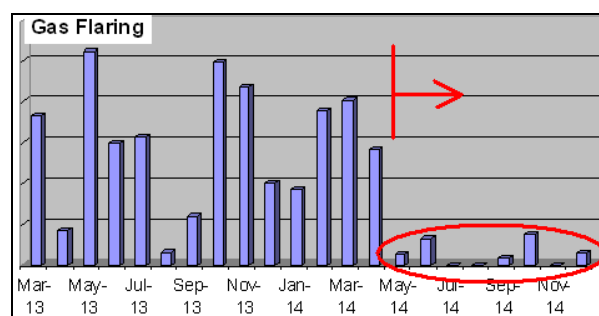

Fig. 11. Flaring reduction with less compressor shutdown.

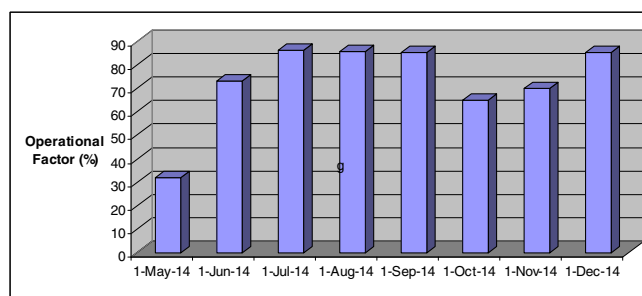

Fig. 12. Operational factor of the anti-slug control.

Operational efficiency is defined as the actual production of the month divided by the possible production considering the wells available and the plant conditions. Figure 13 shows that anti-slug control improved operational efficiency around 1.5% in one particular platform. Such improvement represents economic gains of approximately three millions of dollars per year for this particular offshore platform, considering the oil price of 60 US\$ / bbl. Although it is not trivial to establish a precise cause-effect relationship, we believe that this anti-slug advanced control was one of the major factors responsible for reducing production losses and increasing operational efficiency.

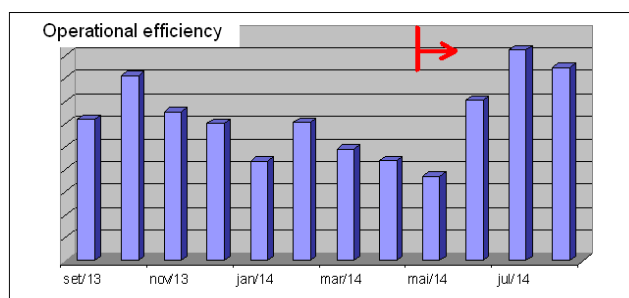

Fig. 13. Operational efficiency with the controller.

A major challenge after implementation of anti-slug advanced controls is to keep applications in use and with good performance. Therefore, it is very important to keep continuous monitoring in order to tune parameters when necessary to adapt with changes in wells behaviors and process plants.

6 CONCLUSION

In this work, advanced anti-slug control strategies were described and results obtained for three offshore production units were discussed. It was observed that this controller was able to improve operational stability and safety, reducing events of high pressure in production header and the number of trips or unscheduled shutdown in compressor. As a consequence, flaring due to compressor trip was reduced substantially. The economic gains obtained by selling the spared gas were estimated around US\$ 300.000,00 per year in one particular offshore platform. Another important gain of this advanced anti-slug control is to avoid flaring above the permitted by regulatory agencies avoiding fines payments, as a consequence.

In one platform, the system was able to increase operational efficiency in about 1.5 %, which represents an economic gain of about US\$ 3.000.000,00 per year. Although it is difficult to establish a precise cause-effect relationship, it was believed that this anti-slug advanced control was one of the major factors responsible for this better operational efficiency. Another qualitative gain with this advanced control system was to automate best operational practices, thereby implementing a kind of knowledge management, which ensures high productivity, even with operator's shift change or the arrival of young operators.

Finally, production platforms are becoming more complex and require advanced control systems to support operators and engineers in order to increase safety, profitability and operational reliability. This paper has presented the economic gains obtained with an anti-slug advanced control.

ACKNOWLEDGEMENT

We would like to thank all technicians and engineers from Petrobras, Trisolutions, Modec, PUC-RIO (Tecgraf), UFSC (Federal University of Santa Catarina), UFRJ (Federal University of Rio de Janeiro) and UFRGS (Federal University of Rio Grande do Sul) involved in development and implementation presented in the paper, as well as their help and contribution.

REFERENCES

American Petroleum Institute – API (2000). Guide to Advanced Control Systems. *API Recommended Practice 557*, First edition.
Campos, M., Teixeira, H., Liporace, F. and Gomes, M. (2009). Challenges and problems with advanced control and optimisation technologies. *International Symposium on Advanced Control of Chemical Process – ADCHEM-2009*.

Campos, M., Teixeira, A., Von Meien, O., Neto, S., and Santos, W. (2013). Advanced Control Systems for Offshore Production Platforms. *Offshore Technology Conference, OTC Brazil*.
Carvalho, M., Bomfim, C., Souza, D., Campos, M., Menezes, B. Caminhas, W., Alves, D. and Araujo, C. (2010). Desenvolvimento do Controlador Não-Linear On-line Neuro-Fuzzy Controler – ONFC-DW e Aplicação na Indústria de Petróleo. *XVIII Congresso Brasileiro de Automática (CBA)* (in portuguese).
Carvalho, M. (2010). *Controlador NeuroFuzzy com aprendizado on-line: Teoria e Aplicação na Indústria de Petróleo*. Master thesis, Universidade Federal de Minas Gerais, Brazil, (in portuguese).
Dalsmo, M., Halvorsen, E. and Slupphaug, O. (2002). Active Feedback Control of Unstable Wells at the Brage Field. *SPE Annual Technical Conference and Exhibition*, (SPE 77650).
Hu, B. (2004). *Characterizing gas-lift instabilities*, PhD Thesis, Norwegian University of Science and Technology.
Godhavn, J., Odhavn, J., Strand, S. and Skofteland, G. (2005a). Increased Oil Production by Advanced Control of Receiving Facilities, IFAC.
Godhavn, J., Fard, M. and Fuchs, P., (2005b). New slug control strategies, tuning rules and experimental results. *Journal of Process Control*, 15, 547–557.
Gouvea, M. R. (2005). *Controle Neurofuzzy de Motor de Indução Com Estimção de Parâmetros e Fluxo de Estator*. PhD Thesis, Universidade Federal de Minas Gerais, (in portuguese).
Kaasa, G., Alstad, V., Zhou, J. and Aamo, O. (2007). Nonlinear Model-Based Control of Unstable Wells. *Modeling, Identification and Control*, 28, 3, 69-79.
Pickering, P., Hewitt, G., Watson, M. and Hale, C. (2001). The prediction of flows in production risers – truth & myth? *IIR Conference*.
Sinegre, L. (2006). *Dynamic study of unstable phenomena stepping in gas-lift activated wells*. These Docteur de l'Ecole des Mines de Paris.
Stasiak, M., Pagano, D. and Plucenio, A. (2012). A New Discrete Slug-Flow Controller for Production Pipeline Risers, *IFAC Workshop - Automatic Control in Offshore Oil and Gas Production*.
Storkaas, E., Skogestad, S. and Godhavn, J. (2003). A Low Dimensional Model of Severe Slugging for Controller Design and Analysis. *Proc. Multi Phase'03*.
Storkaas, E. (2005). *Stabilizing control and controllability. Control solutions to avoid slug flow in pipeline-riser systems*. Ph.D. thesis, Norwegian University of Science and Technology.
Storkaas, E. and Skogestad, S. (2007). Controllability analysis of two-phase pipeline-riser systems at riser slugging conditions. *Control Engineering Practice*.
Taitel, Y. and Dukler, A. E. (1976). A model for predicting flow regime transitions in horizontal and near horizontal gas-liquid flow. *AIChE Journal*.