

Design of Power Steering Systems for Heavy-Duty Long-Haul Vehicles

Emilia Silvas* Eric Backx* Theo Hofman* Henk Voets**
Maarten Steinbuch*

* Eindhoven University of Technology, Control Systems Technology Group, Mechanical Engineering Dept., P.O. Box 513, 5600 MB Eindhoven, The Netherlands. (email: e.silvas@tue.nl)

** DAF Trucks N.V., P.O. Box 90065, 5600 PT Eindhoven, The Netherlands.

Abstract: Conventionally, all auxiliaries present in a heavy-duty vehicle (e.g., power-steering pump, air-conditioning compressor) are engine-driven systems, which put high constraints on their performance. Outputs (e.g., speed, temperature) and energy consumption are dictated by engine speed, while most auxiliary demands are not proportional to the engine speed. Dealing with worst-case scenarios leads to highly oversized components that further, dramatically reduce the overall efficiency. How to choose, in a *simultaneous design step*, a topology, component sizes and a control algorithm for auxiliaries is still unknown. This becomes, especially, important when an integrated general optimal design is desired for the vehicle rather than an optimal system or sub-system design. To overcome the drawbacks of a sequential design approach, this paper shows the precise combination of technology, topology, size and control for the power steering system used in a heavy-duty vehicle. Modeling of six possible topologies and optimal sizing of components, as the gear ratio between combustion engine and power steering pump, are shown. Next, a sensitivity analysis is done for control parameters and a view is presented on a suitable topology for a power steering system used in a heavy-duty long-haul vehicle.

Keywords: Optimal Design, Power Steering Pump, Electrical (Assisted) Steering

1. INTRODUCTION

The possibility of electrifying various components of a vehicle, aiming at reducing fuel, emissions, cost or increase performance, is an increasing field of research. Supported by the grow in popularity of the hybrid electric vehicle (HEV), this enables the transition from relative less efficient (hydraulic, or engine driven systems) to more efficient (electric mechanical, electric machine (EM) driven) components. A HEV refers to the combination of one or more EMs with one energy carrier as the Combustion Engine (CE), but can also represent, referred to as a hybrid vehicle (HV), any other combination of two power sources. Within both hybrid and conventional vehicles, depending on the application, the auxiliaries consume significant amounts of fuel. Previous research articles show power consumption estimates of auxiliaries for various commercial vehicles, but none of these papers addresses the problem of optimal design for these units. This implies the optimal selection of topology, technology, sizes and control algorithm, Silvas et al. [2012]. For instance, Kluger and Harris [2007] show that auxiliary units consume between 3% and 11% for heavy-duty trucks and between 8% and 15% for mini-vans; Petterson and Johansson [2006] show between 5% and 7% for a Scania truck, while a report from US-Council [2010] shows that this consumption can be up to 25% of the total power for a transit bus. Naturally, one might expect various percentages since the power requirements of different auxiliaries vary with respect to the application area,

functionalities, environmental factors (e.g., temperature) and different duty cycles. Moreover, these consumption estimates do not account for the energy required to drive the auxiliaries, which makes a significant difference for a newly developed system. Therefore, finding the optimal design for these auxiliaries constitutes both a challenging research area as well as a commercial interest for manufactures.

For heavy-duty vehicles, among all auxiliaries, the power-steering (PS) pump, depicted in Figure 1, has the biggest potential in terms of reducing the fuel consumption as shown in Hendricks and O'Keefe [2002] and Silvas et al. [2013]. In the work of these authors, the potential of

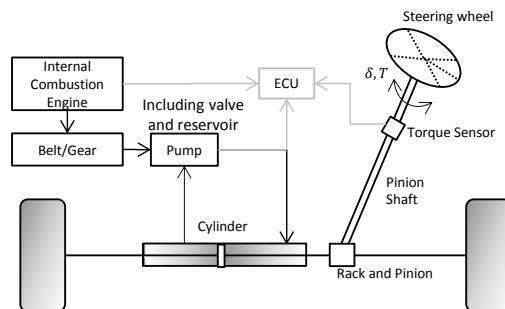

Fig. 1. Simplified schematic representation of a conventional steering system

eliminating the power-steering pump from the engine is

shown (Hendricks and OKeefe [2002]) as well as adding it back to the driveline via the alternator (Silvas et al. [2013]). In recent works by Hu et al. [2008], El-Shaer et al. [2009], Chen et al. [2008], Liu et al. [2008] several controllers are designed for PS systems, particularly for electric-power assisted steering (EPS), used in passenger vehicles. These controllers are built based on priority given hardware (i.e. topology, technology and size) and focus on steering performance, the steering feel of the driver or other challenges as summarized in Grüner et al. [2008]. Recent research for the main power-train components shows that this sequential design approach, as defined by Fathy et al. [2001], can be improved if also topology, technology and size are considered integrated with the controller design. As an alternative solution for passenger vehicles, an electro-hydraulic PS system is presented in Kemmetmuller et al. [2007]. Here, when compared with a traditional hydraulic power-steering system, up to 75% reduction in fuel consumption is shown for the NEDC (New European Driving Cycle) driving cycle. Following these works the question remains on how one can choose for the optimal topology and sizes for the steering system and its sub-systems, for both conventional and hybrid power-trains.

In this paper an analysis is done for the PS system, where six configurations are developed (including conventional hydraulic pump, electrically driven hydraulic pump, electrically steering systems and more complex configurations derived from these) and the optimization problem is defined to find the component sizes. Next, the fuel consumption is calculated for various constant flows within the the pump and various driving cycles. Finally, based on the presented results, indications are given on the applicability of each topology to a particular vehicle class and conclusions are drawn.

2. OPTIMAL DESIGN OF STEERING SYSTEMS

From a general perspective the problem of optimally designing a hybrid vehicle, constitutes an multi-objective optimization problem with a tremendously big design space, as motivated in Silvas et al. [2012], and with a multidisciplinary character, Allison and Herbery [2013]. This can be particularized to PS systems as depicted in Figure 2 and will be defined in the sections that follow.

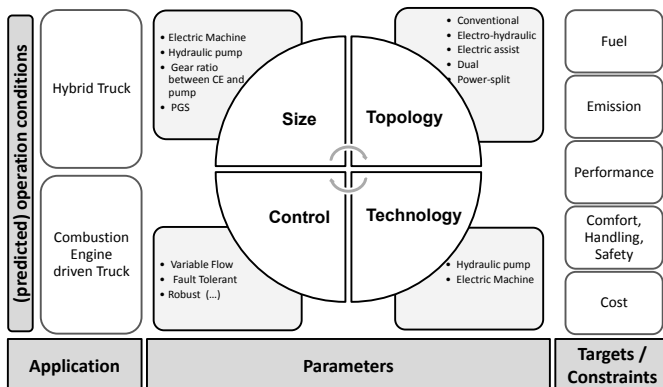

Fig. 2. Steering system design problem for heavy-duty (hybrid) vehicles

For the truck considered here, in Silvas et al. [2013] the power consumption of the auxiliary units is presented and can add up to 4% for a long-haul predominant usage. Figure 3 shows the six possible configurations that have been build for the steering system based on a given set of components (i.e., EM, ICE, planetary gear set, alternator and belts/gears). Each configuration is represented by a certain color/lines characteristics and present the following working principles: (1) combustion engine directly driven Hydraulic Steering (fixed displacement) Pump (H-SP), (2) Electro-Hydraulic Power Steering (EH-PS), (3) power Split Hydraulic Steering Pump (SH-PS), i.e. the combination of H-SP and EH-PS via a planetary gear set, (4) Electro-Hydraulic in combination with a Hydraulic Power Steering (EHH-PS), (5) Electric assisted Hydraulic Power Steering (E-H-PS) and finally (6) Electric Power Steering (E-PS).

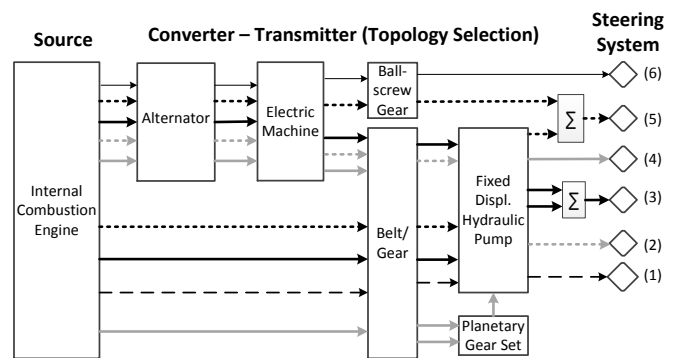

Fig. 3. Overview of the six possible topologies (one per line type) for the steering system

In a EHH-PS topology, a H-SP can be combined with a EH-PS to lower the fuel consumption at higher speeds at the expense of fuel consumption at low speeds. To ease the understanding of Figure 3, the SH-PS topology is depicted in Figure 6 from Section 5, which enables the same functionality as the EHH-PS system, but requires only one pump. Introducing a battery pack to supply electric power is also possible, yet this is not considered here as it would increase the design space for the plant and the controller design. For reasons of comparison, in all cases, the electrical power is generated by a belt driven alternator with a constant efficiency of $\eta_a = 0.70$, for the alternator; and, $\eta_b = 0.80$, for the belt is assumed respectively.

3. OPTIMIZATION PROBLEM

The objective of each configuration is to minimize the fuel consumption, denoted as Φ , (or produced CO_2 emissions) over a representative drive cycle, $\Lambda \subseteq \mathbf{R}^{3 \times n}$, defined as $\Lambda = [s(n) d(n) v(n) c(n)]^T$ and consisting of $n = [1, t_f]$ data points, where $s(\cdot)$ is the slope, $d(\cdot)$ is the distance, $v(\cdot)$ is the speed, $c(n)$ is the curvature and t_f is the final time value of the driving cycle. Next, the sizing and control optimization problem can be defined, in the most general sense, as a co-design problem defined in Reyer et al. [2001], Reyer and Papalambros [2002],

$$\begin{aligned} \min_{x_c, x_d \subseteq \mathcal{X} \subseteq \mathbf{R}^{1 \times n}} J &= \min_{x_c, x_d \subseteq \mathcal{X}} \int_0^{t_f} \Phi_{c,d}(x_c(t), x_d) dt, \\ \text{s.t.} \quad g_{d,c}(x_c(t), x_d) &\leq 0, \\ h_{d,c}(x_c(t), x_d) &= 0. \end{aligned} \quad (1)$$

Here $(\cdot)_d$ denotes a parametric sizing variable and $(\cdot)_c$ denotes a control variable. Depending on the topology, the design variables (x_c, x_d) , detailed in Table 1, and the objective to be minimized, $\Phi_{c,d}$, are

$$x_c = \{f_h, f_n\}, \quad (2)$$

$$x_d = \{i_1, i_2, P_e, z, l, A\}, \quad (3)$$

$$f_{d,c} = \Phi(x_c, x_d) = \dot{m}_f, \quad (4)$$

$$f_{d,c} : \mathbf{R}^{1 \times n} \times \mathbf{R}^{1 \times n} \mapsto \mathbf{R}^{1 \times n}, \quad (5)$$

with \dot{m}_f the fuel mass flow rate.

Table 1. Optimization Design Variables

Design variable	Symbol	Units
Fixed gear ratio (ICE-pump)	i_1	—
Electric machine rated power	P_e	kW
Fixed gear ratio (EM-pump)	i_2	—
Fixed gear ratio PGS	z	—
Ball-screw lead	l	m/rev
Steering house piston area	A	m^2
Min. const. flow on highway	f_h	L/min
Min. const. flow on national roads	f_n	L/min

In Table 2 the set of design variables, for each topology, are depicted. The set of inequality constraints, $g_{d,c}$, and equality constraints, $h_{d,c}$, are dictated by the physical properties of the system and they must be defined for each configuration in Figure 3. An example, for a complex topology is shown in the results section. When $x_c \neq \emptyset$ the output flow (f_h and f_n) of the electrically driven pump can be varied. For example, when there is no input at the steering wheel while driving on the highway, the flow can be reduced in order to save energy.

Table 2. Design Variables for each topology

Variable	i_1	P_e	i_2	z	l	A	f_h	f_n
Topology 1	■							
Topology 2		■	■				■	■
Topology 3	■	■	■	■			■	■
Topology 4	■	■	■				■	■
Topology 5	■		■		■	■		
Topology 6		■	■		■			

Ideally, this problem can be solved by a simultaneous optimization problem which, if any, will provide the global optimum value for the control and sizing parameters searched at the cost of high computational time. Here, next, this problem is split into a nested (bi-level) optimization problem, concept defined by H.K. Fathy and Ulsog [2001], where the optimal sizing is solved by

$$\begin{aligned} \min_{x_d \subseteq \mathcal{X} \subseteq \mathbf{R}^{1 \times n}} J_d &= \\ \min_{i_1, i_2, P_e, z, l, A \subseteq \mathcal{X}} \int_0^{t_f} \dot{m}_f(i_1, i_2, P_e, z, l, A) dt, & \quad (6) \\ \text{s.t.} \quad g_d(i_1, i_2, P_e, z, l, A) &\leq 0, \\ h_d(i_1, i_2, P_e, z, l, A) &= 0, \end{aligned}$$

and the control problem is solved by

$$\begin{aligned} \min_{x_c \subseteq \mathcal{X} \subseteq \mathbf{R}^{1 \times n}} J_c &= \min_{f_h, f_n \subseteq \mathcal{X}} \int_0^{t_f} \dot{m}_f(f_h, f_n) dt, \\ \text{s.t.} \quad g_c(f_h, f_n) &\leq 0, \\ h_c(f_h, f_n) &= 0. \end{aligned} \quad (7)$$

To avoid the optimization algorithm getting stuck in a local minimum, a derivative free optimization algorithm is most suitable for these design problems. The downside of these algorithms is that they generally require (very) large computation times. To overcome the problem of (non)convergence of the global optimal solution, for the sizing problem, we solve (6) using a brute-force search over the design vectors. Then, with the same approach, in a nested manner, for each chosen set of x_d the control problem is solved for a discrete grid of f_h and f_d . When using a brute-force search method the design space is subdivided into an equidistant grid for each dimension and the objective function is evaluated for all feasible points in this grid. Although this method will not provide as output, the true global minimum, it will enable one to make a comparison between different designs. Moreover, the method is straightforward, suitable for low-dimensional optimization problems where only indicative values are required and represents a good starting method to fully understand the complexity of the problem. Given the high number of design variables, insights on the optimal design problem should be given in a Pareto distribution form. This offers insight into the optimal design set and leaves a certain degree of freedom to the designer as well.

4. MODELING OF POWER STEERING TOPOLOGIES

In general, there exist three types of pump models: (i) *empirical* models, based on measured data, are particularly useful when an accurate representation of a particular, existing pump is required, (ii) *physical* models, sometimes less accurate for a particular pump but more uniform, and hence more useful for new pump development, and (iii) *analytical* (or coefficient) models, that can be seen as a combination of the first two. In this latest model type only a limited amount of measurement data is used to determine coefficients that result from physical relations.

Due to limited amount of available data from the real pump, here, the analytical models will be built that include both leakage losses, (caused by the small gaps between the vanes and the housing) and torque losses, T_l , (induced by friction). The required, effective torque, T_e , and the hydro-mechanical efficiency, η_{hm} , of the pump are defined by

$$T_e = T_i + T_l, \quad (8)$$

$$\eta_{hm} = \frac{T_i}{T_e}, \quad (9)$$

where T_i is the ideal pump torque, a function of pressure and angular speed. The amount of leakage flow, q_l , and friction torque (and therewith volumetric and hydro-mechanical efficiency) depend on operating conditions, i.e.

$$\begin{aligned} q_l &= q_l(\Delta p, \omega, \theta, p, \mu, \dots), \\ T_l &= T_l(\Delta p, \omega, \theta, p, \mu, \dots), \end{aligned} \quad (10)$$

where Δp is the pressure difference across the pump, θ is the operating temperature and μ is the dynamic viscosity of the fluid.

The hydro-mechanical efficiency, η_{hm} , and the total efficiency from mechanical to hydraulic power, η_{tot} , are further deduced from a four-pole notation as

$$P_m = T \cdot \omega \quad (11)$$

$$= \Delta p \cdot 1/\eta_{hm} \cdot D \cdot \omega, \quad (12)$$

$$\eta_{hm} = \frac{\Delta p \cdot D}{T}, \quad (13)$$

$$P_h = \Delta p \cdot q \quad (14)$$

$$= \Delta p \cdot D \cdot \eta_v \cdot \omega, \quad (15)$$

$$\eta_{tot} = P_h/P_m \quad (16)$$

$$= \frac{\Delta p \cdot D \cdot \eta_v \cdot \omega}{\Delta p \cdot \frac{1}{\eta_{hm}} \cdot D \cdot \omega} \quad (17)$$

$$= \eta_{hm} \cdot \eta_v, \quad (18)$$

where P_m is the mechanical input power, P_h is the hydraulic output power of the pump, D is the instantaneous displacement volume and η_v is the volumetric efficiency. Next, this structure, consisting of a volumetric and a hydro-mechanical efficiency, is used to describe the fixed displacement pump for all topologies. Results for modeling and validation of a fixed displacement pump have been shown by the authors in Silvas et al. [2013].

Mathematical descriptions of these PS systems are build and validated. Scaling of the EM is done using linear scaling. When there are no variables to be controlled, the optimal design problem boils down to a one degree of freedom optimization problem (PSP, E-HPS and EPS topologies).

4.1 Duty cycle

For each topology, the solution to the design optimization problem depends on the duty cycle of the PS system. Sequentially, the duty cycle is drive cycle dependent and therefore the optimal solution for inner city driving will not always equal the optimal solution for highway driving. For the results presented here, focused on long-haul usage, a mixed cycle measured on a fully loaded tractor-trailer is used, that combines various road segments, with a predominant (85%) highway driving.

5. SIMULATION RESULTS FOR THE OPTIMAL SIZING AND CONTROL

5.1 Variable flow control for the hydraulic pump

The EH-PS, SH-PS and the EHH-PS topologies enable a controlled oil flow, which means that the output flow of the electrically driven pump, ϕ , can be varied depending on driving conditions. For example, when there is no input at the steering wheel while driving on the highway, the flow can be reduced in order to save energy. The minimum flow (f_h, f_n) at certain driving conditions is restricted by safety reasons as it takes some time before the pump delivers the required flow and pressure when it is accelerated from a stand-by mode. Since the flow reduction capability is an

important benefit of these topologies, it has been included by means of different use cases. In the first three use cases, the flow is varied when driving on highways and national roads as: (flow I) $f_h = 11, f_n = 16$, (flow II) $f_h = 6, f_n = 16$ and (flow III) $f_h = 6, f_n = 11$. On the drive cycles that are used for the simulations, these flows are sufficient throughout the cycles. The fourth use case serves as a lower bound of what is achievable when the flow could be varied exactly according to the steering wheel input. This use case (flow IV) is applied on all the drive cycles and can be described mathematically as

$$\phi = \begin{cases} \phi_r, & \text{for } \phi_r > 6 \text{ L/min;} \\ 6 \text{ L/min} & \text{for } \phi_r \leq 6 \text{ L/min,} \end{cases} \quad (19)$$

with ϕ_r the required flow.

5.2 Pareto analysis per-topology

For the first given topology (H-PS), the results for using this method are graphically depicted in Figure 4, where one can observe that the lowest feasible gear ratio results in the lowest average fuel consumption. As this topology has no control freedom, solving (1) boils down to a one degree of freedom optimization problem (2), with $x_d = \{i_1\}$ and an active constraints given by

$$q_{min} - D \cdot i_1 \cdot \omega_i + k_l \cdot p_{sh} \leq 0, \quad (20)$$

where q_{min} is the minimum flow, ω_i is the CE idling speed, p_{sh} is the steering house pressure and k_l is the leakage flow coefficient. For this optimization the grid size per dimension is 20 and the simulation time is 15 minutes. The minimum flow at certain driving conditions is restricted by safety reasons. It is assumed that variable flow can only be applied when driving on highway or national road, since on other roads the steering duty cycle is much higher. When more variables are to be optimized a Pareto frontier

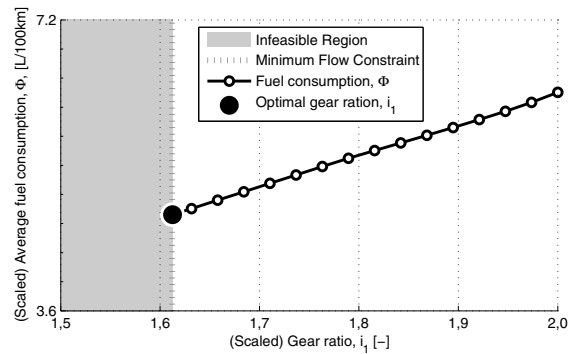

Fig. 4. Pareto front for optimal gear selection in the H-SP Topology

set for the design solutions can be found. This implies that it is impossible to chose for a *more optimal* solution for one design variable without making another design variable worse. Such a result is depicted in Figure 5 for the second topology, EH-PS. This tradeoff is by itself a result and can help in creating a prediction of how would the fuel consumption change with an increase in the gear ratio or the motor power. For this case, one could observe that with an increase of EM power also an increase in the gear used is required in order to keep the low fuel

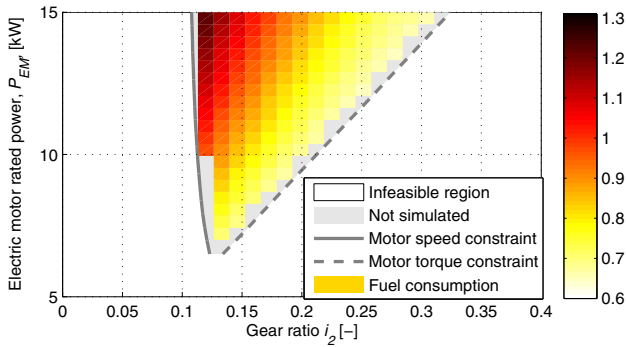

Fig. 5. Optimal size selection of the EH-PS topology with respect to optimal fuel consumption

consumption. When these results are compared to the fuel consumption of the conventional PS system, it shows that the EH-PS system is only beneficial when variable flow is applied intensively (flow IV). In more detail, the dual energy conversion reduces the overall efficiency, and the electric motor has to be sized such that it can deliver enough power at the worst case scenario, i.e. high steering pressures, while mostly the required hydraulic pressure is much lower. This implies that the torque demand on the EM is relatively low most of the time and the EM is not operated in its high-efficiency region. The resulting average efficiency of the electric motor/controller is 30% for this use case. For this reason, the hybrid topologies are advantageous solutions as an efficient engine driven pump is combined with variable flow.

A complete sizing example for the optimal design problem can be built for the complex topology SH-PS depicted in Figure 6, as

$$\begin{aligned} \min_{i_1, i_2, P_e, z \in \mathcal{X}} \int_0^{t_f} \dot{m}_f(i_1, i_2, P_e, z) dt, \\ \text{s.t.} \\ q_{min} - D\left(\frac{z+1}{z}i_1\omega_i - \frac{1}{z}\omega_u i_2\right) + k_l p_{sh} \leq 0, \quad (21) \\ T_r \frac{i_2}{z} - T_u \eta_i \eta_{pgs} \leq 0, \\ \frac{(z+1)\omega_c - z\omega_r}{i_2} - \omega_u \leq 0. \end{aligned}$$

Here ω_u is the maximum electric motor angular speed, T_r

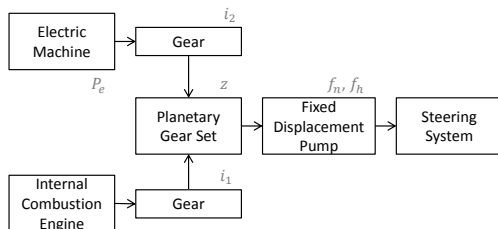

Fig. 6. Schematic representation of the SH-PS topology from Fig. 3

is the required pump torque, T_u is the maximum electric motor torque, ω_r is the required pump speed, η_i is the efficiency of the fixed i_2 gear and η_{pgs} is the efficiency of the planetary gear set. These three constraints define

the feasible design space for this topology. Solving (21) for $x_d = \{i_1(k), i_2(k), P_e(k), z(k)\}$, where k is the number of grid points per dimension yields $x_d = \{0.38 \ 0.34 \ 4.8 \ 7.6\}$. This subset of the attainable set is called a *Pareto set* and consists of *Pareto optimal points*. A point $x_{d_x} \subseteq \mathcal{X}$ is Pareto optimal if and only if there is no other $x_d \subseteq \mathcal{X}$ such that $x_d < x_{d_x}$, in this case with an extra (equality) constraint that fixes the planetary gear ratio. From this Pareto plot, one can conclude that there is a range of planetary gear ratio's within the attainable set \mathcal{X} resulting in about the same fuel consumption. Therefore the planetary gear set can be chosen according to secondary aspects, such as availability or packaging restrictions. Because of the

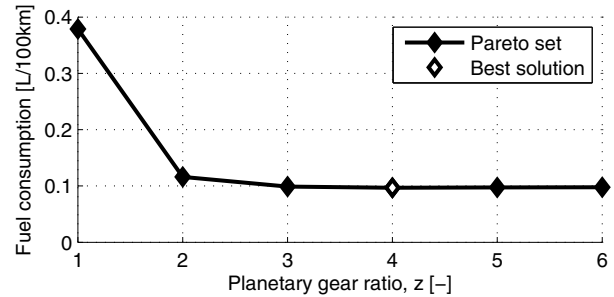

Fig. 7. Pareto graph for the optimal planetary gear ratio, z , in the SH-PS topology

large flexibility in gear combinations it is not known what combinations are likely to result in a low fuel consumption. Therefore, the design space of the planetary gear set was chosen according to constructional (in)feasibility.

5.3 Comparison of the six topologies

The comparison of these 6 topologies for all defined oil flows and the optimal set $x_{d_x} \subseteq \mathcal{X}$ is depicted in Figure 8. When variable flow is applied intensively on all roads (use case IV), the fuel consumption of the EHH-PS may even be reduced by up to 80% compared to the conventional system. The simulation time to simulate one complex topology (e.g., SH-PS) goes up to 7 hours and 30 minutes. The benefit of E-PS, enabling true steering on demand, makes this solution very attractive for passenger cars but cannot overcome the arising issues when E-PS is applied to heavier vehicles. First, the required power to drive the electric motor has to be delivered by the battery and second, the the electric motor has to be powerful enough to steer the wheels at vehicle standstill. This would require a very high torque output and might also bring a weight increase when compared with its hydraulic counterpart. The brute-force search showed that the analyzed E-PS topology is not feasible for a conventional truck, having a 24 V battery.

An E-H-PS could be a good alternative, combining the benefits of 'power on demand' with the conventional hydraulic steering system. The resulting benefit of this topology is not impressive since the of the pump is still sized for the worst case scenario. Another benefit of E-H-PS topology is that the piston area of the steering house can be reduced, such that less oil flow is required. Compared to the H-SP topology, the average fuel consumption has been reduced by 15% with the use of a 2.4 kW motor.

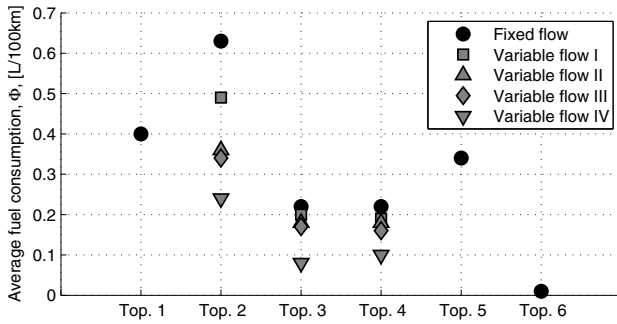

Fig. 8. Influence of the minimum flow for different topologies

From Figure 8 one can conclude that, for all topologies, lowering the minimum flow improves the fuel efficiency. The topologies and the approach shown here offer both insights on the functionality of the system and enable the visualisation of trade-offs between choosing one or another value (see Figures 4, 5 and 7) for different parameters explained in Table 1.

6. CONCLUSIONS

In this work a novel framework for understanding and approaching the optimal design of auxiliary systems present in a heavy-duty vehicle from a more general perspective. This is then particularized to six topologies of the power steering system. By using a co-design optimization approach optimal Pareto design sets are found. The results show that, depending on the duty cycle, complex topologies can reduce fuel consumption by more than 80% when compared with conventional, hydraulic steering systems. Moreover, they can also enable functions as start/stop and zero emission driving. These benefits are achieved also due to the possibility to control the oil flow and they can be improved with the decrease of the minimum constant flow.

Future work will try to integrate more auxiliaries and address some critical secondary aspects (e.g., cost, steering performance) for designing these systems.

ACKNOWLEDGEMENTS

This work is supported by DAF Trucks N.V., Eindhoven, the Netherlands.

REFERENCES

James T. Allison and Daniel R. Herbery. Multidisciplinary design optimization of dynamic engineering systems. In *AIAA Multidisciplinary Design Optimization Specialist*, 2013.

Xiang Chen, Tiebao Yang, Xiaoqun Chen, and Kemin Zhou. A generic model-based advanced control of electric power-assisted steering systems. *IEEE Transactions Control Systems Technology*, 16(6), 2008.

A.H. El-Shaer, S. Sugita, and M. Tomizuka. Robust fixed-structure controller design of electric power steering systems. In *American Control Conference (ACC)*, pages 445–450, June 2009.

H. K. Fathy, J. A. Reyer, P. Y. Papalambros, and A. G. Ulsoy. On the coupling between the plant and controller

optimization problems. *IEEE American Control Conference*, 3:1864–1869, 2001.

S. Grüner, A. Gaedke, and Gerald G. Karch. Control of electric power steering systems - from state of art to future challenges. In *Proceedings of the 17th World Congress The International Federation of Automatic Control*, pages 10756–10757, 2008.

T. Hendricks and M. OKeefe. Heavy vehicle auxiliary load electrification for the essential power system program: Benefits, tradeoffs, and remaining challenges. In *SAE Technical Paper Series*, 2002.

P.Y. Papalambros H.K. Fathy, J. A. Reyer and A. Galip Ulsoy. On the coupling between the plant and controller optimization problems. In *Proceedings of the American Control Conference*, pages 1864–1869, June 2001.

Tsung-Hsien Hu, Chih-Jung Yeh, Shih-Rung Ho and Tsung Hua Hsu, and Ming-Chih Lin. Design of control logic and compensation strategy for electric power steering systems. In *IEEE Vehicle Power and Propulsion Conference*, 2008.

Wolfgang Kemmetmuller, Steffen Muller, and Andreas Kugi. Mathematical modeling and nonlinear controller design for a novel electrohydraulic power-steering system. *IEEE/ASME Transactions on Mechatronics*, 12(1):85–97, 2007.

M. Kluger and J. Harris. Fuel economy benefits of electric and hydraulic off engine accessories. In *SAE International*, 2007.

L. Liu, M. Nagai, and P. Raksincharoensak. On torque control of vehicle handling and steering feel for avoidance maneuver with electric power steering. In *Proceedings of the 17th World Congress The International Federation of Automatic Control*, pages 12073–12078, Seoul, Korea, July 6-11 2008.

N. Pettersson and K. H. Johansson. Modelling and control of auxiliary loads in heavy vehicles. *Int. Journal of Control*, 79(5):479–495, 2006.

Julie A. Reyer and Panos Y. Papalambros. Combined optimal design and control with application to an electric dc motor. *Journal of Mechanical Design*, 124:183–191, 2002.

Julie A. Reyer, Hosam K. Fathy, , Panos Y. Papalambros, and A. Galip Ulsoy. Comparison of combined embodiment design and control optimization strategies using optimality conditions. *ASME Design Engineering Technical Conference and Computers and Information in Engineering Conference*, 2001.

Emilia Silvas, Theo Hofman, and Maarten Steinbuch. Review of Optimal Design Strategies for Hybrid Electric Vehicles. volume 3(1), pages 57–74, 2012.

Emilia Silvas, Omer Turan, Theo Hofman, and Maarten Steinbuch. Modeling for Control and Optimal Design of a Power Steering Pump and an Air Conditioning Compressor used in Heavy Duty Trucks. In *Proceedings of the 9th IEEE Vehicle Power and Propulsion Conference*, pages 218–223, October 2013.

National Research US-Council. *Technologies and Approaches to Reducing the Fuel Consumption of Medium- and Heavy-Duty Vehicles*. Washington, DC: The National Academies Press, 2010.