

A Control-Relevant Model of Subcutaneous Insulin Absorption ^{*}

Michael Vilkhovoy ^{*,**} Ari Pritchard-Bell ^{*}
Gilles Clermont ^{*,***,****} Robert S. Parker ^{*,***,****}

^{*} Department of Chemical and Petroleum Engineering, Swanson School of Engineering, University of Pittsburgh, Pittsburgh, PA 15261. (email: aap64, cler, rparker@pitt.edu)

^{**} Department of Chemical Engineering, University of Massachusetts – Amherst, Amherst, MA 01003. (mvilkhov@umass.edu)

^{***} Department of Critical Care Medicine, University of Pittsburgh, Pittsburgh, PA 15261

^{****} McGowan Institute for Regenerative Medicine, University of Pittsburgh, Pittsburgh, PA 15219

Abstract: Critically ill patients suffer from “stress hyperglycemia,” a diabetes-like condition of elevated glucose concentrations. The outcomes from controlling glucose levels are mixed; some trials have shown significant reductions in morbidity and mortality rates for patients, while the NICE-SUGAR trial debates this result. The current state of critical care practice is a conservative approach to glucose control, where physicians maintain glucose levels via strategic administration of insulin, and the result is mild-to-moderate hyperglycemia for patients. Automating this insulin delivery process can improve glucose control, while mitigating hypoglycemia, using mathematical model-based tools. Key to clinical implementability and performance is a subcutaneous insulin delivery model. The proposed model is a reduction of an extended Wilinska model (Wilinska et al. (2005)) that captures plasma insulin dynamics after insulin administration. The proposed model holds for regular and rapid-acting insulins administered via bolus injection or continuous infusion. The model parameters were fit to clinical data from insulin-dependent diabetics and healthy patients administered insulin. Regular insulin data were fit simultaneously across three dose levels by adjusting the rate parameters. Fast acting insulin data were fit separately from regular insulin, and similarities and differences between fast-acting insulin analogues were observed. The subcutaneous model, integrated with our previously-published whole body model (Roy and Parker (2006)) is able to accurately capture plasma glucose levels of patients published in the literature. Our overall objective is to couple this system-level model to a model-based control algorithm to facilitate clinical decision-making for glucose control and insulin delivery in critical care.

Keywords: Biomedical Systems, Insulin Sensitivity, Critical Care, Nonlinear Models, Parameter Estimation

1. INTRODUCTION

A critically ill patient admitted into the Intensive Care Unit (ICU) commonly experiences diabetes-like physiology such as elevated glucose levels and decreased insulin sensitivity, termed “stress hyperglycemia.” As a result, the amount of insulin produced by the body is insufficient to normalize glucose concentrations (80-120 mg/dl). A seminal study by van den Berghe *et al.* (2001) reported that tight glycemic control can dramatically reduce mor-

bidity, mortality, and overall survival in the post-surgical ICU. Attempts to replicate the results of this study, however, have been inconclusive, and the more recent NICE-SUGAR study (Finfer et al. (2009)) was unable to achieve the results in (van den Berghe et al. (2001)). While this may be due to an increased level of hypoglycemia encountered in (Finfer et al. (2009)), the inconclusive nature of the clinical trial results has led the clinical standard of care to remain open-loop in form and to recommend tolerance of stress hyperglycemia, in spite of compelling evidence that it may be associated with worse outcomes. Clinicians maintain glucose levels via strategic insulin dosing based protocols, including glucose targets and insulin administration sliding scales, that vary by hospital. It is our goal to develop an automated model-based decision support system (DSS) that has the potential to provide several critical benefits to clinicians and patients: (i) a decrease in the amount of time clinicians need to spend

^{*} This material is based upon work supported by the National Science Foundation (United States) under Grant No. EEC-1156899 (MV, RSP) and the National Institute of Diabetes and Digestive and Kidney Diseases of the National Institutes of Health (United States) under award number R21DK098213 (AP, GC, RSP). The content, including any opinions, findings, and conclusions or recommendations expressed in this material, is solely the responsibility of the authors and does not represent the official views of the National Science Foundation or the National Institutes of Health.

on maintenance tasks such as glucose monitoring/insulin administration for well-controlled patients; (ii) a decrease in the glucose variability associated with patient ICU stay, with the goal of achieving performance similar to that in (van den Berghe et al. (2001)); and (iii) a decrease in the number and severity of hypoglycemic episodes experienced by ICU patients.

A crucial element of the DSS is an accurate model of patient dynamics, and in particular, insulin dynamics after administration in the ICU. Insulin is typically injected intravenously until glucose levels are deemed stable, at which point the patient is switched to continuous subcutaneous insulin infusion (CSII) or bolus administration due to lower incidence of infection and to improve patient “mobility” by not having them “tied” to an IV insulin infusion pump (a different device than the ambulatory pumps used by diabetics today). Insulin is normally administered to the subcutaneous tissue of the abdominal wall, where it is subsequently absorbed into the bloodstream. Modeling the absorption of subcutaneous insulin administration is complex and can be affected by many factors. These factors include: site of administration (Koivisto and Felig (1980)) and/or depth of injection, blood flow (Nucci and Cobelli (2000)), type of insulin (Kang et al. (1991)), and insulin concentration (Binder et al. (1984)). While these issues can be addressed by using multiple factor-dependent models, a single model structure is preferable for practical controller implementation as part of a model-based DSS for ICU use. This paper will address the synthesis and refinement of a model describing plasma insulin appearance following subcutaneous insulin delivery for regular and fast-acting insulin.

2. MODELING METHODS AND ANALYSIS

Model selection begins with the best model (as measured by Akaike Information Criteria (AIC)) from (Wilinska et al. (2005)), herein referred to as the Wilinska model. Starting from this model, we use a combination of literature data sets to further tailor the model to our requirement: the ability to capture plasma insulin dynamics following subcutaneous administration of different types of insulin (*i.e.*, regular, fast-acting) using a single structure, but different parameter values. As in (Wilinska et al. (2005)), the AIC is used to balance model complexity with quality of fit (as quantitated by sum of squared error between model predictions and literature data) for the studied types of insulin.

2.1 Wilinska Model

Wilinska *et al.* (2005) evaluates 11 different compartmental models for insulin dynamics, finding “model 10” to be the best for subcutaneous insulin administration (via either bolus injection or continuous infusion) of rapid-acting insulin analogues in insulin-dependent diabetics. This model is presented in Figure 1, and has two different pathways of insulin absorption. The model also incorporates a saturable local degradation of insulin along both the fast and slow absorption pathways, characteristic of the degradation of delivered insulin at the site of injection. For the purposes of ICU use, there are two concerns: (i) the model is untested in fitting insulin dynamics in the

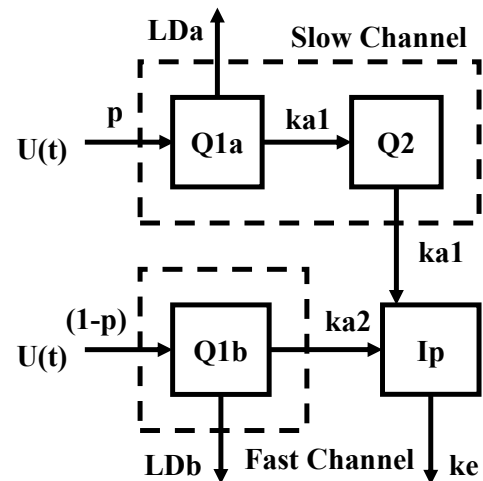

Fig. 1. Wilinska model: Subcutaneous insulin absorption for bolus and continuous administration of rapid-acting insulin analogues for insulin-dependent diabetics. (Wilinska et al. (2005)) Insulin injection is represented as $U(t)$ (mU) with the amount distributed between the two channels determined by a fraction, p . Compartments $Q_{1a}(t)$ and $Q_{1b}(t)$ (mU), represented as masses of insulin, represent insulin that can degrade (via LD_a and LD_b) or be absorbed into the plasma. Compartment $Q_2(t)$ (mU) captures the slower dynamics associated with the fraction, p , of insulin administered. $I_p(t)$ (mU/L) represents insulin in the plasma compartment. The transfer rates of the model are k_{a1} , k_{a2} and k_e (1/min). LD_a and LD_b (mU/min) are Michaelis-Menten functions that capture local degradation at the insulin administration site.

ICU population; and (ii) the model is not developed for regular insulin, which is used alongside fast-acting insulin analogues in the ICU. Thus, the Wilinska model is used as a starting point for building an ICU-relevant model that can capture the plasma insulin dynamics for a variety of insulin types, administration routes, and patients.

2.2 Novel Insulin Absorption Model

Our objective is to develop a subcutaneous insulin absorption model to capture the insulin dynamics for different types of patients, types of insulin, and types of injection (*e.g.*, infusion or bolus). With regular insulin having slower dynamics than the fast-acting insulin analogues, the “extended” Wilinska model as shown in Figure 2 was generated by adding an extra compartment, $Q_{sc}(t)$, preceding both the fast and slow channels. The insulin injected passes into the Q_{sc} compartment and is then distributed into both channels according to their fraction coefficients (p or $1-p$). The local Michaelis-Menten degradation was kept for the first compartment of each channel. An additional fitted rate parameter, denoted k_2 , replaced the k_{a1} parameter in the slow channel between $Q_2(t)$ and $I_p(t)$, in order to better capture plasma insulin levels after regular insulin administration. This model is termed the “extended” Wilinska model below.

These modifications to the Wilinska model allow it to capture both rapid-acting and regular insulin. However,

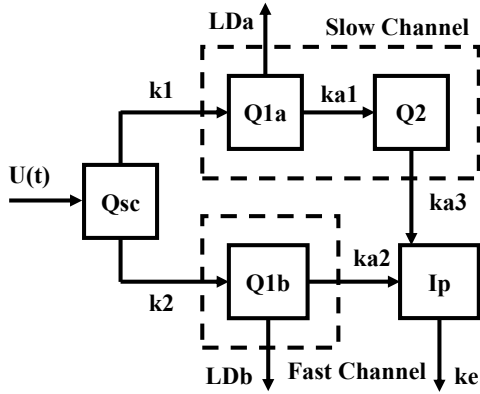

Fig. 2. Extended Wilinska model: Compartment Q_{sc} was added to replace the partition coefficient, p , from the original Wilinska model. Parameters k_1 and k_2 now represent the relative kinetic rates of slow or fast insulin, respectively. All other parameters remain from the original Wilinska model previously described in Figure 1.

in adding a slow initial dynamic, the need for the dual-channel structure, particularly the fast-channel dynamics, after $Q_{sc}(t)$ was unclear. Reducing the model by eliminating the fast channel, its associated rate parameters, and the insulin split (p vs. $1 - p$) yields the model shown in Figure 3.

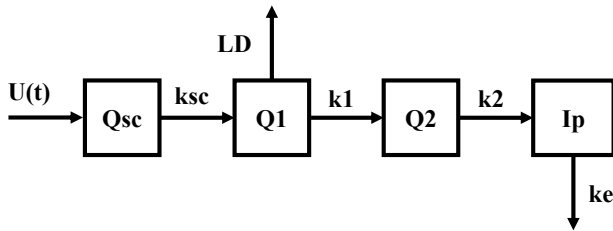

Fig. 3. Reduction of the extended Wilinska model. Subcutaneous insulin absorption for varying types of patients, injections and insulin.

This four-compartment structure is characterized by the following equations:

$$\frac{dQ_{sc}(t)}{dt} = u(t) - k_{sc}Q_{sc}(t) \quad (1)$$

$$\frac{dQ_1(t)}{dt} = k_{sc}Q_{sc}(t) - k_1Q_1(t) - \frac{V_{max}Q_1(t)}{k_{MD} + Q_1(t)} \quad (2)$$

$$\frac{dQ_2(t)}{dt} = k_1Q_1(t) - k_2Q_2(t) \quad (3)$$

$$\frac{dI_p(t)}{dt} = \frac{k_2Q_2(t)}{V} - k_eI_p(t) \quad (4)$$

Here, $Q_{sc}(t)$ is the slower-dynamics compartment added as part of the “extension.” The amount of insulin administered as continuous infusion or bolus injection is given by $u(t)$. $Q_{sc}(t)$, $Q_1(t)$ and $Q_2(t)$ (in mU) represent compartmentally the pharmacokinetics of subcutaneous insulin absorption. The plasma insulin is represented by $I_p(t)$ (mU/L). V (L) is the insulin distribution volume. The transfer rate constants of the model are k_{sc} , k_1 , k_2 and k_e (1/min). The local degradation (the LD path in Figure 3)

is governed by Michaelis-Menten kinetics in equation (2), with constants V_{max} (mU/min) as the maximum insulin degradation rate and k_{MD} (mU) as the insulin mass at which insulin degradation is equal to half of its maximal value.

2.3 Parameter Estimation

The parameters for each of the models were estimated using nonlinear least-squares regression. The error between model predictions and data at each time point was weighted by the inverse of the standard deviation of the data at that point in time, as follows:

$$\min_{\theta} J(\theta) = \sum_{i=1}^N \left[\frac{y_i - y(t_i, \theta_1 \dots \theta_M)}{\sigma_i} \right]^2 \quad (5)$$

Here, y_i is the measured data at time t_i , which has a standard deviation of σ_i . The model prediction is given by $y(t_i, \theta_1, \dots, \theta_M)$, which depends on θ_j , $j \in [1, M]$, the model parameters. N is the number of data points, and M is the total number of model parameters.

Certain model parameters were fixed at literature values, rather than fitting them to data, as follows. Parameter k_{MD} , part of the Michaelis-Menten insulin degradation term, was fixed to the value reported in (Wilinska et al. (2005)): $k_{MD} = 62.6$ mU. Parameter V , the insulin volume of distribution is fixed to the value reported in (Roy and Parker (2006)), $V = 7.6$ L. The remaining transfer rates, k_{sc} , k_1 , k_2 , k_e and V_{max} were estimated using published data of plasma insulin levels after subcutaneous insulin administration. Upon fitting to the data, parameter confidence intervals were broad and overlapping, and the degradation maximum rate (V_{max}) was similar in both insulin types. As a result, V_{max} was fixed to a value of 1.22 mU/min for both insulin types, consistent with the physiological range provided in (Wilinska et al. (2005)).

Since regular and fast-acting insulin have different dynamics, two parameter sets (one each for regular and fast-acting insulin) were generated by simultaneously fitting data for the appropriate insulin type to the corresponding data regardless of administration mechanism (bolus injection vs. continuous infusion). For the fast-acting insulin analogues, data from both Lispro and Aspart was used. The resulting parameter values for k_{sc} , k_1 , k_2 , and k_e are, therefore, specific to insulin type (regular vs. fast-acting).

The 95% confidence intervals of the estimated parameters were computed by using *nlparci* in MATLAB (©2013, The Mathworks, Natick, MA). In order to generate conservative bounding envelopes for the model predictions, all parameters were varied to three levels (minimum confidence interval bound, nominal value, maximum confidence interval bound), and all combinations of these parameters were simulated. The maximum and minimum insulin concentration predictions at each point in time were collected from these simulation sets and used to establish the bounding envelope for insulin concentration predictions.

2.4 Akaike Information Criterion

The Akaike Information Criterion (AIC, Akaike (1979)) is computed for each of the models to establish a statistical

comparison between the Wilinska model, the “extended” Wilinska model and our low-order model. The AIC is computed as follows:

$$AIC = N \ln \left(\frac{J(\theta)}{N} \right) + 2M \quad (6)$$

Here, N is the number of data points, and M is the number of model parameters. The criterion is minimized over choices of M to form a tradeoff between the quality of fit of the model to the data and the complexity of the model, as represented by its number of parameters, M . The model having the lower AIC score is preferred.

2.5 Clinical Data

Two different clinical studies were used to fit the plasma insulin data for regular insulin (highly purified porcine insulin; Actrapid MC, 40 U/mL, Novo Industries, Denmark). From (Kraegen and Chisholm (1984)), ten normal subjects were given a 10 U subcutaneous “bolus” of insulin over 5 minutes. To suppress endogenous insulin release from the pancreas, the patients were given an IV insulin infusion of 1 U/hr into the contralateral arm for 60 minutes before the study began. The plasma insulin level at time 0 of the study is used as the steady state plasma insulin for the model fit. In (Kobayashi et al. (1983)), nine insulin-dependent diabetics and three normal subjects were studied. In the bolus arm, insulin was delivered by a single subcutaneous injection at a dose of 0.15 U/kg body weight. In the continuous infusion arm, six subjects were administered the same dose of insulin over 60 minutes.

Fast-acting insulin analogue data came from two additional studies. A clinical study from (Hedman et al. (2001)) examined fourteen insulin-dependent diabetic subjects and compared two fast-acting analogues. Participants were injected subcutaneously with a 10 U bolus of insulin Lispro (Humalog, 100 U/mL, Eli Lilly, Indianapolis, IN) and (on a different day) a 10 U bolus of insulin Aspart (NovoRapid, 100 U/mL, Novo-Nordisk, Bagsveard, Denmark). The parameter set fit to the Hedman clinical study is validated using data from a clinical study of 24 insulin-dependent diabetic patients using the same insulin at a subcutaneous bolus dose of 7.1 ± 1.3 U (Plank et al. (2002)).

3. RESULTS

Subcutaneous insulin absorption into the plasma varies by insulin type. Regular insulin has a hexameric structure that cannot be readily absorbed into the plasma and must be broken down (an equilibrium process) into its dimeric and monomeric forms prior to plasma absorption. Fast-acting insulin analogues, however, have only monomeric structure and are easily absorbed into the plasma. As a result, we fit different parameter sets (rate constants), with fixed compartmental model structure, to the two insulin types: regular vs. fast-acting.

3.1 Regular Insulin

The transfer rates (Table 1) in the model are estimated simultaneously for all clinical studies that used purified

porcine-derived regular insulin. Three different insulin doses, corresponding to the specific clinical protocol, are simulated: a 10 U subcutaneous (sc) bolus over five minutes (Kraegen and Chisholm (1984)); a 9 U bolus over one minute (Kobayashi et al. (1983)); and a 7 U continuous subcutaneous insulin infusion (CSII) over 60 minutes (Kobayashi et al. (1983)).

Table 1. Estimated parameter set for regular insulin in healthy patients and insulin-dependent diabetics across dose levels and administration routes.

Parameter	Value	CI	Units
k_{sc}	0.018	0.002	1/min
k_1	1.08	0.052	1/min
k_2	0.015	0.001	1/min
k_e	0.14	0.0081	1/min
V_{max}	1.22	-	mU/min

Figure 4 displays the model simulation for the regular insulin along with the maximum and minimum predicted plasma insulin profiles based on the parameter confidence intervals. The model from Figure 3 captures the dynam-

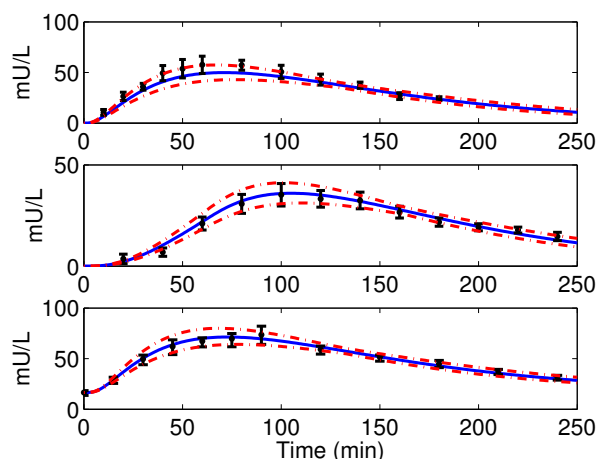

Fig. 4. Plasma insulin model simulation (solid line) and 95% confidence interval envelope (bounded by dashed lines) versus published data (dots, mean \pm SD) for regular insulin. Top: 9 U subcutaneous bolus to insulin-dependent diabetics. Middle: 7 U CSII over 60 minutes to insulin-dependent diabetics. Bottom: 10 U subcutaneous bolus over 5 minutes to normal patients.

ics of regular insulin administration via CSII and subcutaneous bolus injection in healthy patients and insulin-dependent diabetics. The envelope of model predictions, based on the confidence intervals of the fitted parameters, is within the standard deviation of the published data for each clinical study.

3.2 Fast Acting Insulin Analogue

The transfer rates (Table 2) were estimated simultaneously for the Hedman clinical study involving both insulin Lispro and insulin Aspart.

Figure 5 displays the model simulation for subcutaneously-injected insulin Lispro (top) and insulin Aspart (bottom)

Table 2. Estimated parameter set for insulin Aspart and insulin Lispro in insulin-dependent diabetics.

Parameter	Value	CI	Units
k_{sc}	0.0743	0.016	1/min
k_1	0.3486	0.0071	1/min
k_2	0.0085	0.00001	1/min
k_e	0.2056	0.0204	1/min
V_{max}	1.22	-	mU/min

in insulin-dependent diabetic patients. The maximum and minimum plasma insulin predictions are also shown. By

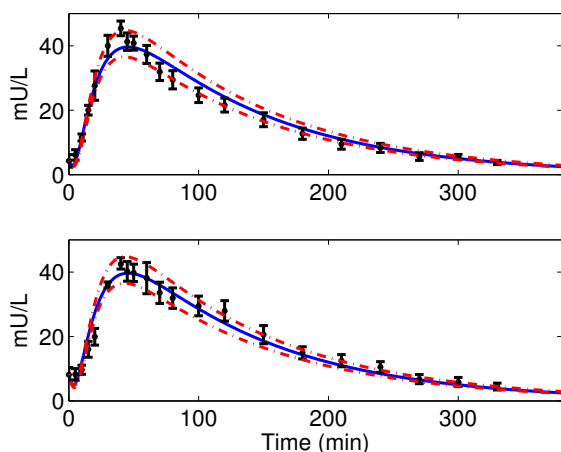

Fig. 5. Plasma insulin model simulation (solid line) and 95% confidence interval envelope (bounded by dashed lines) versus published data (dots, mean \pm SD) for rapid-acting insulin administered by subcutaneous bolus to insulin-dependent diabetic patients. Top: 10 U insulin Lispro. Bottom: 10 U insulin Aspart.

changing parameter values, but not structure, our model captures the dynamics of the fast-acting insulin analogues Lispro and Aspart after a bolus injection to insulin-dependent diabetics. As above, the envelope of model predictions, based on the confidence intervals of the fitted parameters, is within the standard deviation of the published data for the clinical study (Hedman et al. (2001)).

Model validation, using the parameters estimated above, is shown in Figure 6 for a 6.8 U subcutaneous bolus injection of the same fast-acting insulin analogues (Plank et al. (2002)). Upon validation at the lower insulin dose, the simulated insulin responses are in good agreement with the measured experimental data, and the envelope of model predictions, based on the confidence intervals of the fitted parameters, is within the standard deviation of the published data for the clinical study (Plank et al. (2002)).

3.3 Model Comparison and Analysis

The AIC value provides a measure of model quality, trading off the relative merits of predictive accuracy and model complexity (as measured by the number of fitted parameters). AIC scores were computed for the Wilinska model, the “extended” Wilinska model and the low-order model. The results are shown in Table 3. All models score well on fast-acting insulin, though AIC is an absolute measure indicating that the low-order model is superior. This is

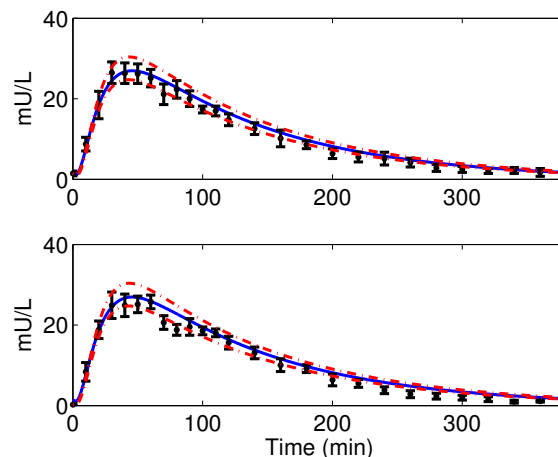

Fig. 6. Plasma insulin model simulation (solid line) and 95% confidence interval envelope (bounded by dashed lines) versus published data (dots, mean \pm SD) for rapid-acting insulin administered by subcutaneous bolus to insulin-dependent diabetic patients. Top: 6.8 U insulin Lispro. Bottom: 6.8 U insulin Aspart.

Table 3. Calculated AIC values of the three models of subcutaneous insulin administration.

Model	Error	Parameters	AIC
Wilinska	184.2	10	87.0
“Extended” Wilinska	18.3	14	-84.9
Low-Order Model	17.1	10	-98.5

notable given that the Wilinska model was constructed with the objective to capture rapid-acting insulin analogue absorption dynamics. When evaluating regular insulin, only the “extended” Wilinska and low-order models were able to capture the slower dynamics. Hence, for a fixed structure and insulin-dependent parameter fitting, the low-order model is the superior choice.

Our model is a mathematical representation of the absorption dynamics of insulin into the plasma. The absorption of insulin through the subcutaneous tissue can be complex with many factors that may have an effect on absorption. In comparing the estimated parameter sets for regular and fast-acting insulin, it can be observed the transfer rates, k_{sc} , k_2 and k_e , have a higher magnitude than that of the regular insulin estimated parameter set. The physiological clearance rate, k_e , has been reported to be dependent on the patient, thus k_e is left as an estimated parameter to each clinical study. Our clearance rate for both parameter sets is within the physiological bounds reported in (Wilinska et al. (2005)).

The physiological accuracy of the local degradation term, LD , is the subject of some debate as discussed in (Wilinska et al. (2005)). Like Wilinska et al., we choose to keep the $LDSS$ term in our model due to the flexibility it adds for capturing multiple types of insulin. This will be an important component of any model grounded more in the physiology of insulin elimination as the elimination rate, k_e , will not be set by a subcutaneous model, but will be dependent on the systemic elimination rate. Hence, the ability to calibrate a model to a patient while keeping

systemic elimination at the patient's individual value will likely require model structural flexibility, as housed in the LD term.

The low-order subcutaneous insulin model was coupled with a model of glucose and insulin dynamics Roy and Parker (2006); Roy (2008). Regular and fast-acting insulin challenges were simulated when 2U were administered at the same time as a 40g oral nutrition (glucose) challenge, as shown in Figure 7. The simulated meal dynamics

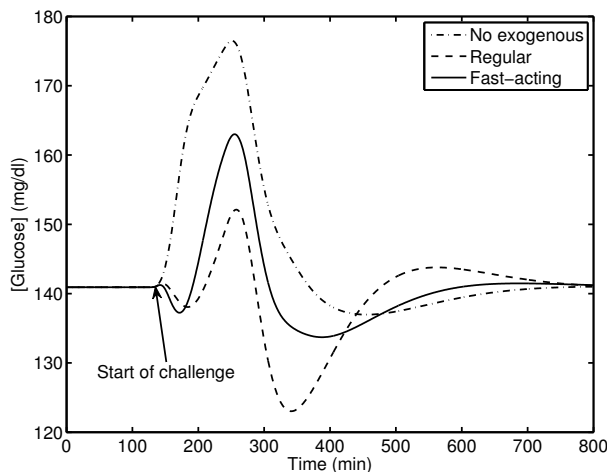

Fig. 7. Glucose response to bolus subcutaneous insulin administration. A 2U bolus of either fast-acting (solid line) or regular (dashed line) insulin is delivered over 5 minutes, beginning simultaneously to the administration of a 40g glucose meal. Both insulin doses are compared to the control case where no insulin is administered (dash-dot line).

were based on the trapezoidal gastric emptying model of (Lehmann and Deutsch (1992)), with intestinal absorption modeled as in (Roy (2008)). The coupled insulin and glucose models were able to capture the different glucose profiles resulting from subcutaneous administration of regular versus fast-acting insulin. This type of challenge shows that the subcutaneous insulin delivery model provides a reasonable starting point for making predictions and supporting treatment decisions in critical care.

4. CONCLUSION

Three subcutaneous insulin absorption models have been evaluated in order to capture the plasma insulin dynamics for regular and fast-acting insulin analogues, for healthy and type-1 diabetic patients, and CSII and bolus injections. The model with the lowest AIC score, representing the preferred trade-off of model complexity and accuracy, captures plasma insulin dynamics for different types of insulin and various patient conditions. The model will be used in the development of a control algorithm that will facilitate clinical decision-making for glucose control and insulin delivery in critical care.

REFERENCES

Akaike, H. (1979). A Bayesian Extension of the Minimal AIC Procedures of Autoregressive Model Fitting. *Biometrika*, 66, 237.

- Binder, C., Lauritzen, T., Faber, O., and Pramming, S. (1984). Insulin pharmacokinetics. *Diabetes Care*, 7(2), 188–99.
- Finfer, S., Chittock, D.R., Su, S.Y.S., Blair, D., Foster, D., Dhingra, V., Bellomo, R., Cook, D., Dodek, P., Henderson, W.R., Hébert, P.C., Heritier, S., Heyland, D.K., McArthur, C., McDonald, E., Mitchell, I., Myburgh, J.A., Norton, R., Potter, J., Robinson, B.G., and Ronco, J.J. (2009). Intensive versus conventional glucose control in critically ill patients. *The New England Journal of Medicine*, 360(13), 1283–97. doi: 10.1056/NEJMoa0810625.
- Hedman, C., Lindström, T., and Arnqvist, H. (2001). Direct comparison of insulin lispro and aspart shows small differences in plasma insulin profiles after subcutaneous injection in type 1 diabetes. *Diabetes Care*, 24(6).
- Kang, S., Brange, J., Burch, A., Volund, A., and Owens, D. (1991). Subcutaneous Insulin Absorption Explained by Insulin's Physicochemical Properties. *Diabetes Care*, 14(11), 942–948.
- Kobayashi, T., Sawano, S., Itoh, T., Kosaka, K., Hirayama, H., and Kasuya, Y. (1983). The Pharmacokinetics of Insulin After Continuous Subcutaneous Infusion or Bolus Subcutaneous Injection in Diabetic Patients. *Diabetes*, 32, 331–336.
- Koivisto, V. and Felig, P. (1980). Alterations in insulin absorption and in blood glucose control associated with varying insulin injection sites in diabetic patients. *Annals of Internal Medicine*, 92(1), 59–61.
- Kraegen, E.W. and Chisholm, D.J. (1984). Insulin Responses to Varying Profiles of Subcutaneous Insulin Infusion: Kinetic Modelling Studies. *Diabetologia*, 26, 208–213.
- Lehmann, E.D. and Deutsch, T. (1992). A Physiological Model of Glucose-Insulin Interaction in Type 1 Diabetes Mellitus. *J. Biomed. Eng.*, 14, 235–242.
- Nucci, G. and Cobelli, C. (2000). Models of Subcutaneous Insulin Kinetics. A Critical Review. *Comp. Meth. Prog. Biomed.*, 62, 249–257.
- Plank, J., Wutte, A., Brunner, G., Siebenhofer, A., Semlitsch, B., Sommer, R., Hirscherger, S., and Pieber, T.R. (2002). A direct comparison of insulin aspart and insulin lispro in patients with type 1 diabetes. *Diabetes Care*, 25(11), 2053–7.
- Roy, A. (2008). *Dynamic Modeling of Free Fatty Acid, Glucose, and Insulin During Rest and Exercise in Insulin Dependent Diabetes Mellitus Patients*. Ph.D. thesis, Department of Chemical and Petroleum Engineering, University of Pittsburgh.
- Roy, A. and Parker, R.S. (2006). Dynamic Modeling of Free Fatty Acids, Glucose, and Insulin: An Extended Minimal Model. *Diabetes Tech. Theraput.*, 8, 617–626.
- van den Berghe, G., Wouters, P., and Weekers, F. (2001). Intensive Insulin Therapy in Critically Ill Patients. *New England Journal of Medicine*, 345, 1359–1367.
- Wilinska, M.E., Chassin, L.J., Schaller, H.C., Schaupp, L., Pieber, T.R., and Hovorka, R. (2005). Insulin kinetics in type-I diabetes: continuous and bolus delivery of rapid acting insulin. *IEEE Transactions on Biomedical Engineering*, 52(1), 3–12. doi:10.1109/TBME.2004.839639.