

Fuel Optimal Control With Service Reliability Constraints for Ship Power Systems

Harry G. Kwatny* Gaurav Bajpai** Karen Miu*
Murat Yasar**

* Drexel University, 3141 Chestnut Street,
Philadelphia, PA 19104, USA

** Techno-Sciences, Inc., 11750 Beltsville Drive
Beltsville, MD 20705, USA

Abstract: Fuel cost is a major concern for naval and commercial ship operations. One approach to fuel efficiency improvement is to integrate propulsion and electric generating systems. This paper examines the use of hybrid electric drives as a means for reducing fuel costs in naval ship operations. Fuel efficiency can be improved by committing only the necessary power generating resources to supply the propulsion and electric power requirements for the mission. However, it is also necessary to insure a degree of reliability of power supply, which typically implies committing more resources than actually needed. This paper examines fuel optimization in the presence of service reliability constraints. It considers optimal strategies for contingency response as a means of reducing the need to commit excess on-line power generating resources.

Keywords: Fuel optimization, ship power systems, optimal control, nonlinear dynamics

1. INTRODUCTION

2. PROBLEM DEFINITION

The number of power supply sources available on a power system is determined by the need to supply the maximum anticipated electrical and propulsion load. On a naval ship, operational modes that require high level of online resources persist only for a small fraction of the total time a ship is in service. Consequently, a plan for fuel reduction should focus on the low load, normal operations that dominate the ship's lifetime. A significant reduction of fuel consumption can result from running a small number of turbine-generators during these periods. Even during normal operations, however, there is a real risk of contingencies that could lead to the need to curtail load for a period of time. Thus, to insure an acceptable level of reliability of power supply it is necessary to maintain sufficient on-line generation and to distribute it appropriately around the network.

New concepts and technologies have created opportunities for reducing fuel consumption while maintaining, even improving, service reliability. These include energy storage devices, integrated electric power systems and hybrid electric drives. This paper addresses the issue of design of control strategies to enable reliable service while reducing fuel consumption.

This paper is focused on normal operations, as opposed to emergencies, in which case fuel optimization is a meaningful goal. In Doerry and J. V. Amy (2011), the authors draw an important distinction between *survivability* and *quality of service* (QOS). Survivability addresses prevention of fault propagation and restoration of service under severe damage conditions whereas QOS concerns insuring a reliable supply of power to loads during normal operations, see also Doerry (2007) and IEEE Std 1709-2010 (2010). QOS is an important consideration during normal operations because equipment malfunction is a relatively common occurrence. Not all loads have the same requirements for continuity of power supply. As used in Doerry and J. V. Amy (2011), QOS is quantified as the *mean time between service interruptions* where a service interruption is defined as a degraded network condition that lasts longer than a load can tolerate before losing functionality. In IEEE Std 1709-2010 (2010) loads are divided into four categories that depend on two time parameters associated with the power network. T_1 is the reconfiguration time: the maximum time to reconfigure the network without bringing on additional generators. T_2 is the generator start time: the time to bring on-line the slowest generator. Accordingly, four categories of loads are defined:

- (1) Uninterruptible loads: cannot tolerate a power loss of duration T_1 .
- (2) Short term interruptible loads: can tolerate a power loss of duration T_1 , but not T_2 .
- (3) Long term interruptible loads: can tolerate a power loss of duration T_2 .

¹ This research was supported in part by the U. S. Naval Sea Systems Command under Contract No. N00024-12-C-4131. Any opinions, findings and conclusions or recommendations expressed in this material are those of the authors and do not necessarily reflect the views of the Sponsors.

- (4) Exempt loads: loads not considered in evaluating QOS.

Because this QOS metric is intended primarily for DC distribution systems it does not consider power quality measures such as harmonic content, or voltage fluctuations. In fact, it does not consider dynamics at all. In AC systems, however, dynamics are important.

In Lahiri et al. (2011), the authors formulate the fuel optimization problem with QOS constraints, where QOS has a meaning appropriate for AC system power quality. The problem is formulated as follows. Given a time interval, $[0, T]$, over which the ship is to perform a specified mission with corresponding maximum load, ℓ , having a corresponding distribution over the network, determine a commitment, c_ℓ^* , of generation resources that minimizes fuel costs, supplies the load, and also satisfies QOS constraints. In this case the QOS constraints are defined as follows.

Definition 2.1. Given:

- (1) a set of contingency events, $\mathcal{R} = \{r_i, i = 1, \dots, m\}$,
- (2) a set of performance variables (e.g., bus voltages, line currents, frequency), $\mathcal{Y} = \{y_i, i = 1, \dots, p\}$, each variable with a corresponding admissible range so that $Y_{i,\min} \leq y_i(t) \leq Y_{i,\max}$ and a time duration, T_i , for which an out of range value can be tolerated.

The QOS constraints are satisfied if for every $r \in \mathcal{R}$, occurring at any time $t_r \in [0, T]$, at which time the network is in equilibrium, none of the performance variables $y_i(t)$ experience a constraint violation for a duration longer than its corresponding T_i .

The fuel optimization problem as formulated above is naturally a static optimization problem as meaningful fuel cost savings are obtained when measured over a long period of operation. QOS constraints, on the other hand, involve short term dynamics. They are incorporated by eliminating from consideration any otherwise feasible commitment configuration. This is accomplished by evaluating the configuration response to the specified contingencies. No attempt is made to optimize that response. In the present work we expand that analysis to allow the temporary use of load shedding and energy storage to avoid violating contingency constraints. The frame-work proposed here also allows inclusion of load scheduling as a means of fuel conservation.

2.1 Example Ship Power System

Figure 1 illustrates a ship electric power and propulsion system that will be used to demonstrate the concepts discussed below. The system is loosely based on a notional DDG-51 class naval ship with a hybrid electric drive, e.g. McCoy et al. (2007); Castles et al. (2009); McMullen and Dalton (2011). The system includes three gas turbine driven electric generators (GTG) and four propulsion gas turbines (GTM), two on each of two propulsion shafts. Two bi-directional permanent magnet synchronous machines (PMSM), one geared to each propulsion shaft can be used as motors to drive the shaft or as generators to provide electric power to ship power network.

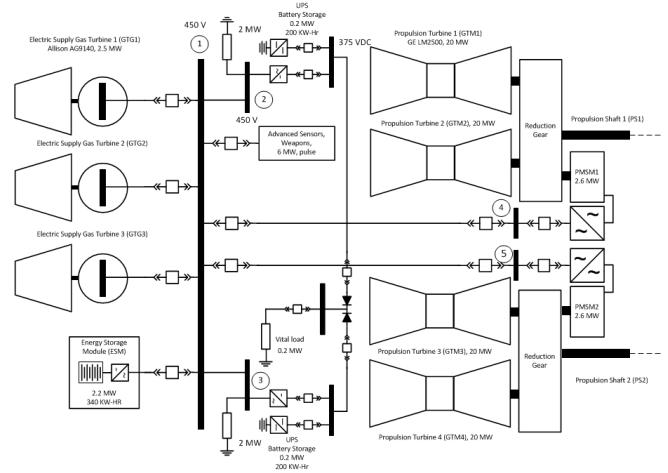

Fig. 1. Notional hybrid electric ship power system based on a DDG 51 class naval ship with hybrid electric drive.

The system can be operated in six configurations defined as follows.

- (1) *Full Power* - 2 turbines (GTM) per shaft driving 2 shafts; 1 or more GTG's supply the electric loads.
- (2) *Split Plant* - 1 turbine (GTM) per shaft driving 2 shafts; 1 or more GTG's supply the electric loads.
- (3) *Trail Shaft* - 1 turbine (GTM) driving 1 shaft, other shaft free; 1 or more GTG's supply the electric loads.
- (4) *HED Motoring* - 1 PMSM driving 1 shaft; 2 or more GTG's supply the electric power.
- (5) *HED generation Split Plant* - 1 turbine (GTM) per shaft driving 2 shafts with PSMS generators supporting 1 or more GTG's in supplying electrical loads.
- (6) *HED Generation Trail Shaft* - 1 turbine (GTM) driving 1 shafts with PSMS generator supporting 1 or more GTG's in supplying electrical loads.

The electrical load is assumed constant over the duration of the analysis. Its value varies with the mission and the season and may range from about 2000 KW to 4500 KW.

3. THE FUEL CONSUMPTION MODEL

It is instructive to first consider the operation of the ship in its various configurations in terms of fuel consumption without regard to QOS constraints. The only constraints considered here, are the generation capacity of each of the generators and the electric power flow constraints of the network.

Fuel consumption data was obtained from the Navy's Energy Conservation Program web site <http://www.i-encon.com>. Based on the DDG 51 CLASS SHIPS data the associated fuel data and fuel curves for both Allison GTGs and GE LM2500 GTMs can be obtained. Curve fits were used to parameterize the data in terms of ship speed, v , in knots. There are three propulsion alignments with distinct fuel curves.

Trail Shaft One GTM engine online and one shaft wind-milling.

$$f_{TS} = 117.17 \exp(0.1087 v)$$

Split Plant One GTM engine online on each shaft.

$$f_{SP} = 181.74 \exp(0.098 v)$$

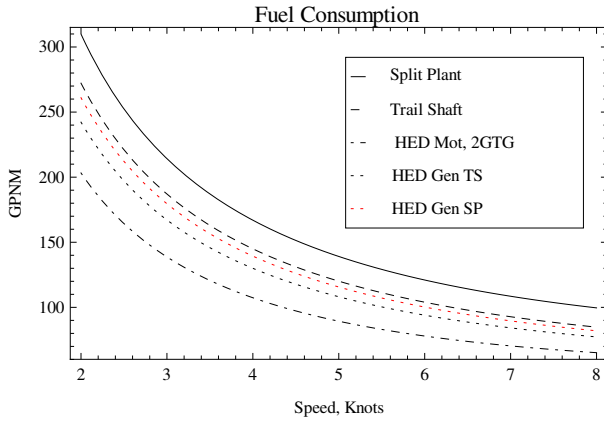

Fig. 2. Low speed fuel consumption as a function of speed in various configurations. Electrical load fixed at 3,000 KW.

Full Power Two GTM engines online on each shaft.

$$f_{FP} = 334.48 \exp(0.082 v)$$

For the **Allison 501-K34** GTG fuel consumption, the curve was parameterized in KW electric load, L and the number of GTGs, N_{GTG} .

$$f_{GTG} = 0.068 L + 97.4 N_{GTG}$$

Figures 2 and 3 show the fuel consumption at low speed (up to 8 knots) and high speed (above 8 knots), respectively, assuming a constant electric load of 3000 KW. Split plant operation has two GTMs operational, one on each shaft with all electric power supplied by two GTGs, as one would not be sufficient. This is the most fuel costly configuration. Trail shaft operation is somewhat better as only one GTM is operational. Note that one GTM can comfortably produce 22 knots. The HED motoring configuration with 2 GTGs supplying 3000 KW, and 1500 KW (or 2011 HP) for propulsion – so that about 8 knots is achievable – with 500 KW remaining. This is the most fuel efficient configuration for low speed operation, see Figure 2. The HED generation configuration allows all of the GTGs to be shut down, but this configuration is not as efficient as motoring.

The HED motoring configuration can only be used above 8 knots with 3 GTGs operational, thereby, increasing fuel consumption and raising it to about the same as trail shaft HED generation. With three GTGs and 3000 KW of electrical load, it can only produce a maximum speed of about 12 knots. Consequently it is omitted from the high speed considerations in Figure 3. In the high speed range, trail shaft HED generation is the most fuel efficient operating configuration. Also note that the optimal speed is in the range of 14-15 knots.

4. OPTIMAL RESPONSE TO CONTINGENCIES

From Section 3, it is clear that without consideration of supply reliability the most efficient operational configuration at low speed is trail shaft HED motoring, and at high speed operation it is trail shaft HED generation. The question now turns to how QOS constraints alters this picture. In accordance with Definition 2.1, to answer this it is necessary to evaluate the candidate configuration

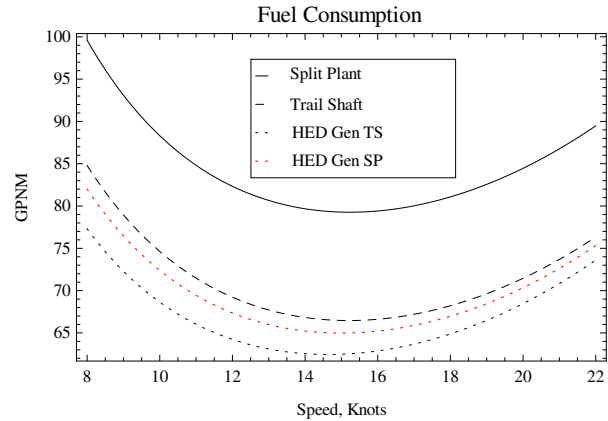

Fig. 3. High speed fuel consumption as a function of speed in various configurations. Electrical load fixed at 3,000 KW.

with respect to all contingency events in \mathcal{R} . This requires delineating the admissible corrective actions to each contingency and then evaluating the corresponding response in terms of continuity of supply variables \mathcal{Y} .

Example 4.2. Low speed Operation: Loss of Generator. As an example, consider operation at 7 knots, so the trail shaft HED motoring is the most fuel efficient configuration. Suppose one of the specified contingencies is loss of one of the two GTGs. Figure 4 illustrates the situation in terms of a state diagram. The normal operating state q_1 consists of two GTGs each producing 2250 KW. The system operating in state q_1 experiences an external event e_1 corresponding to a GTG failure inducing a transition to state q_2 . From the failed state it is desired to restore the system back to the HED motoring state with two GTGs and to do so without violating the QOS requirements. To accomplish this the controller should react with a sequence of corrective actions. In this example the actions to be taken include:

- (1) Start up the spare GTG (it takes 6 minutes to get from shutdown to full power).
- (2) Temporarily drop non-vital load (1000 KW),
- (3) Supply power, temporarily from the emergency storage module (ESM)
- (4) Use the generator crisis capacity (4500 KW for up to 5 minutes).

The discrete states $q_i, i = 2, \dots, 6$ are illustrated along with admissible controllable transitions $s_i, i = 1, \dots, 9$. The contingency triggering event cause the system to transition from q_1 to q_2 . There are four controlled events leading to transition from q_2 . Any departure from state q_2 initiates startup of GTG 3. Now, it is proposed to select the *best* sequence of controlled transitions aimed at satisfying the QOS constraints. If the best does indeed satisfy the constraints as specified in Definition 2.1, then the same process can be followed for the other contingencies until one fails the test. If all contingencies have an adequate response sequence, the the mode is accepted as a valid operating configuration.

In earlier publications Kwatny et al. (2006) and Kwatny et al. (2007) the authors introduced an approach that uses a nonlinear DAE model to describe the continuous state dynamics. Logical specifications are used to define

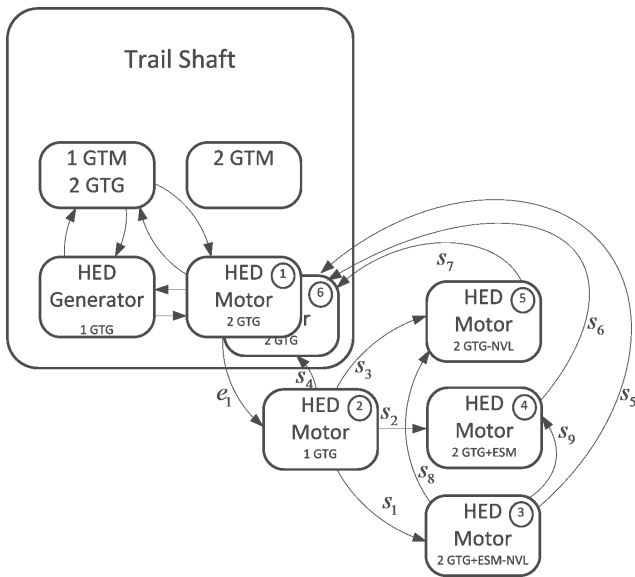

Fig. 4. Possible remedial strategies following loss of GTG from trail shaft motoring configuration.

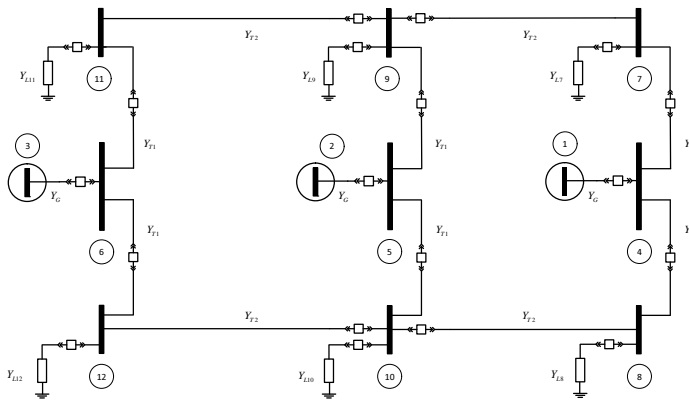

Fig. 5. The distribution network 12 bus configuration includes the generator internal buses.

the admissible transition behavior of the discrete system, to incorporate saturation of the continuous control, to characterize the algebraic constraints of the DAE model, and in the definition of the the cost function. Conversion of the logical specifications to integer formulas using symbolic computation enables the use of mixed-integer dynamic programming to derive an optimal feedback control. This paper adapts this process to the current problem, highlighting new concepts for improving the efficiency of the dynamic programming computations.

4.1 Modeling

The system operates in one of m modes denoted q_1, \dots, q_m . $Q = \{q_1, \dots, q_m\}$ is the discrete state space. The continuous time differential-algebraic equation (DAE) describing operation in mode q_i is

$$\begin{aligned} \dot{x} &= f_i(x, y, u) \\ 0 &= g_i(x, y) \end{aligned} \quad i = 1, \dots, m \quad (1)$$

where $x \in X \subseteq R^n$ is the system continuous state, $y \in Y \subseteq R^p$ is the vector of algebraic variables and $u \in U \subseteq R^l$ is the continuous control. Transitions can occur only between certain modes. The set of admissible

transitions is $\mathcal{E} \subseteq Q \times Q$. It is convenient to view the mode transition system as a graph with elements of the set Q being the nodes and the elements of \mathcal{E} being the edges. We assume that transitions are instantaneous. So, if a system transitions from mode q_1 to q_2 at time t we would write $q(t) = q_1, q(t^+) = q_2$. We allow resets. State trajectories are assumed continuous through events, i.e., $x(t) = x(t^+)$, unless a reset is specified.

Transitions are triggered by external *events* and *guards*. Events are designated s and belong to a set Σ . A guard is a subset of the continuous state space X that enables/disables a transition. A transition enabled by a guard might represent a protection device. Not all transitions have guards and some transitions might require simultaneous satisfaction of a guard and the occurrence of an event.

Each discrete state label, $q \in Q$, and each event label, $s \in \mathcal{E}$ is considered to be a logical variable that takes the value True or False. Guards also are specified as logical conditions. In this way the transition system can be defined by a logical specification (formula) \mathcal{L} .

For computational purposes it is useful to associate with each logical variable, say α , a binary variable or indicator function, δ_α , such that δ_α assumes the values 1 or 0 corresponding respectively to α being True or False. It is convenient to define the discrete state vector $\delta_q = [\delta_{q_1}, \dots, \delta_{q_m}]$. Precisely one of the elements of δ_q will be unity and all others will be zero.

With the introduction of the binary variables the set of dynamical equations (1) can be replaced with the single DAE:

$$\begin{aligned} \dot{x} &= f(x, y, \delta_q, u) = \sum_{i=1}^m \delta_{q_i} f_{q_i}(x, y, u) \\ 0 &= g(x, y, \delta_q) = \sum_{i=1}^m \delta_{q_i} g_{q_i}(x, y) \end{aligned} \quad (2)$$

Remark 4.3. (Power System DAE Models). Power systems are typically modeled by sets of semi-explicit DAEs as given by (1) In any mode q_i the flow defined by (1) is constrained to the set $M_i \subset X \times Y$ defined by $0 = g_i(x, y)$. Ordinarily, it is assumed that M_i is a regular submanifold of $X \times Y$.

Example 4.4. Loss of Generator, Continued. The dynamical behavior in each of the six discrete states shown in Figure 4 will be modeled with reference to the network illustrated in Figure 5. Note that the initial state involves two generators corresponding to buses 1 and 2. The spare generator corresponds to bus 3. It is assumed that the bus 2 generator fails. The difference between the initial state q_1 and the final state q_6 in Figure 4 is that the replacement generator is on a different bus. In summary, the reduced bus network models for the 6 states are:

- State q_1 :** Generator buses 1 and 2, PQ buses 4,5,6, full load.
- State q_2 :** Generator bus 1, PQ bus 4, full load,
- State q_3 :** Generator buses 1 and 3, PQ buses 4,6, vital load,
- State q_4 :** Generator buses 1 and 3, PQ buses 4,6, ESM, full load,
- State q_5 :** Generator buses 1 and 3, PQ bus 4,6, ESM, vital load
- State q_6 :** Generator buses 1 and 3, PQ bus 4,6, full load.

4.2 The Control problem

The system is observed in operation over some finite time horizon T that is divided into N discrete time intervals of equal length. A control policy is a sequence of functions

$$\pi = \{\mu_0(x_0, \delta_{q0}), \dots, \mu_{N-1}(x_{N-1}, \delta_{q(N-1)})\}$$

such that $[u_k, \delta_{sk}] = \mu_k(x_k, \delta_{qk})$. Thus, μ_k generates the continuous control u_k and the discrete control δ_{sk} that are to be applied at time k , based on the state (x_k, δ_{qk}) observed at time k .

Consider the set of m -tuples $\{0, 1\}^m$. Let Δ_m denote the subset of elements $\delta \in \{0, 1\}^m$ that satisfy $\delta_1 + \dots + \delta_m = 1$. Denote by Π the set of sequences of functions $\mu_k : X \times \Delta_m \rightarrow U \times \{0, 1\}^{m_s}$ that are piecewise continuous on X .

The *Optimal Feedback Control Problem* is defined as follows. For each $x_0 \in X, \delta_{q0} \in \Delta_m$ determine the control policy $\pi^* \in \Pi$ that minimizes the cost

$$J_\pi(x_0, \delta_{q0}) = g_N(x_N, \delta_{qN}) + \sum_{k=0}^{N-1} g_k(x_k, \delta_{qk}, \mu_k(x_k, \delta_{qk})) \quad (3)$$

subject to the constraints (1) and the logical specification, i.e.,

$$J_{\pi^*}(x_0, \delta_{q0}) \leq J_\pi(x_0, \delta_{q0}) \quad \forall \pi \in \Pi \quad (4)$$

5. EXAMPLE

Consider, again, the loss of generator 2. This event causes the transition from state q_1 to q_2 as indicated in Figure 4. The goal now is to determine an optimal response strategy for this contingency. Departure from q_2 to any of the states q_3, \dots, q_6 initiates startup of the spare generator (GTG3). It is assumed that the generator power increases at a conservative rate of 250 KW/minute. In units of pu per sec,

$$\dot{P}_3 = 1/1200 \quad (5)$$

The goal is to steer the system from the initial state $P_3 = 0, q = q_2$ to the terminal state $P_3 = 0.45, q = q_6$. This will take 9 minutes since P_3 must reach 0.45 pu from 0 pu. The fast electrical dynamics will be neglected so that the only dynamics are associated with equation (5). Each mode is described by (5) and a set of algebraic equations describing the network.

The nine minute interval is divided into nine one-minute segments, and (5) is replaced by the discrete time equation

$$P_{3,i+1} = P_{3,i} + 60/1200 \quad (6)$$

The goal is to find a sequence of state transitions that steers the system from the initial state $\{0, q_2\}$ to the final state $\{0.45, q_r\}$ such that QOS constraints are met. To do this, an optimal control is sought that minimizes a cost defined to reflect the QOS objectives. In this example, the cost J is

$$J = \sum_{i=4}^{12} |V_i - 1| + \max[0, P_1 - 0.5] + 0.3 \delta_{ESM} + 0.15 \delta_{NVL}$$

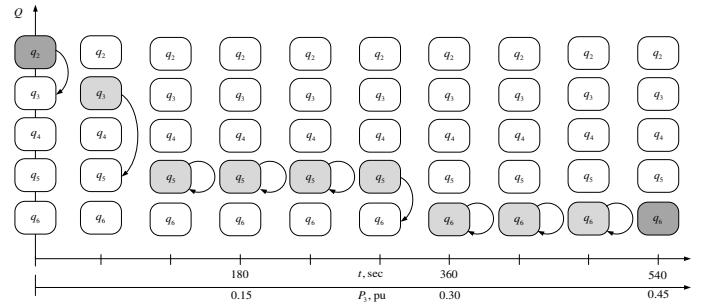

Fig. 6. The optimal strategy is shown in terms of the time period and GTG3 power level.

where δ_{ESM} and δ_{NVL} are binary variables that take the values 0 or 1. $\delta_{ESM} = 1$ denotes the ESM is active and $\delta_{NVL} = 1$ denotes the non-vital load is dropped, whereas in each case, the value zero denotes the opposite. Dynamic programming is used to obtain the switching strategy illustrated in Figure 6. The weights assigned to $\delta_{ESM} = 1, \delta_{ESM} = 1$ are selected to reflect a judgement of the relative cost of employing these actions.

Notice that following the failure, the controller immediately switches to configuration q_3 which means that the non-vital load is dropped and the ESM turned on providing 1000 KW of supporting power. It is worth noting that the power provided by GTG1 is $P_1 = 0.494pu$ which is still below the unit's normal rating of 0.5 pu. If no action is taken, GTM1 would provide 0.786 pu power which is just below the unit's five minute crisis capability (0.9 pu). However, the voltage levels are also unacceptably low. After one minute, the optimal strategy switches to q_5 , in which the ESM is turned off, but the non-vital loads remain disconnected. The GTG1 power output increases to 0.642 pu. The system remains in this state for four minutes by which time the GTG1 power output has dropped below its normal rating to 0.444 pu. At this point the configuration is switched to q_6 , the non-vital load is picked up and the GTG1 power output increase to 0.640 pu. The system remains in this configuration and reaches the target state in four minutes as the GTG1 power output reduces linearly to its target value. Throughout this trajectory the bus voltages remain within acceptable limits.

6. CONCLUSIONS

Using the engine fuel consumption data, a set of possible operational configurations, and mission specific electric load and ship speed requirements it is a straightforward matter to compute the most fuel efficient operating configuration. However, when QOS constraints are imposed, the problem is more complicated. In this case, it is necessary to delineate all credible contingencies and eliminate any configuration which violates the QOS constraints for any one of the contingent events. The occurrence of a contingency should trigger a remedial action designed to prevent violation of the QOS constraints. This paper considers the design of an optimal sequence of available remedial actions. The cost function is constructed from penalties associated with QOS violations which are balanced against costs associated with the using the available remedial actions. With a remediation strategy defined, the response to a contingency can be evaluated to determine if a QOS

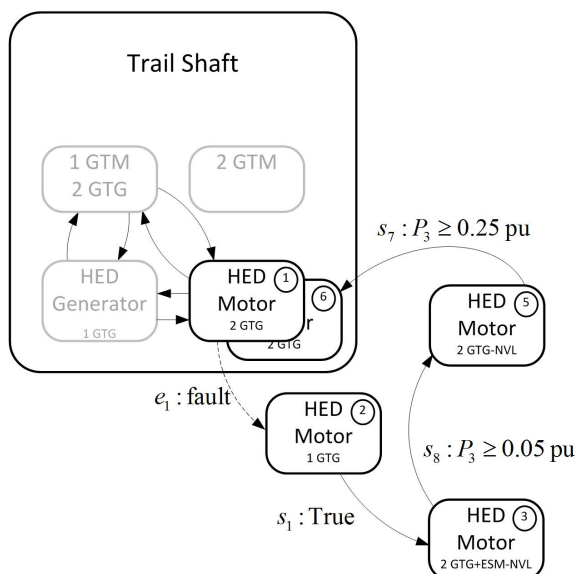

tems and Technologies (MAST) Americas Conference, Washington, DC, 2011.

Fig. 7. The optimal strategy is shown as a discrete state transition diagram.

constraint is violated. A method for doing this is described in this paper and an example is given based on a notional hybrid propulsion version of the U. S. Navy's DDG 51 class ships.

REFERENCES

- G. Castles, G. Reed, A. Bendre, and R. Pitsch. Economic benefits of hybrid drive propulsion for naval ships. In *Electric Ship Technologies Symposium*, pages 515–520, 2009.
- N. H. Doerry and Jr. J. V. Amy. Implementing quality of service in shipboard power system design. In *IEEE Electric Ship Technology Symposium*, Alexandria, VA, 2011.
- Norbert H. Doerry. Designing electric power systems for survivability and quality of service. *ASNE Naval Engineers Journal*, 119(2):25 – 34, 2007.
- IEEE Std 1709-2010. IEEE recommended practice for 1 kv to 35 kv medium voltage dc power systems on ships, 2010.
- H. G. Kwatny, E. Mensah, D. Niebur, and C. Teolis. Optimal power system management via mixed integer dynamic programming. In *2006 IFAC Symposium on Power plants and Systems*, Kananaskis, Canada, 2006.
- H. G. Kwatny, E. Mensah, D. Niebur, G. Bajpai, and C. Teolis. Logic based design of optimal reconfiguration strategies for ship power systems. In *Proceedings 7th IFAC Symposium on Nonlinear Control Systems*, Pretoria, South Africa, 2007.
- S. Lahiri, K. Miu, H. G. Kwatny, G. Bajpai, A. Beyton, and J. Patel. Fuel optimization under quality of service constraints for shipboard hybrid electric drive. In *4th International Symposium on Resilient Control Systems*, Boise, Idaho, 2011. IEEE.
- T. McCoy, J. Zgliczynski, N. W. Johanson, F. A. Puhn, and T. W. Martin. Hybrid electric drive for ddg-51 class destroyers. *Naval Engineers Journal*, (2):83–91, 2007.
- David McMullen and Thomas Dalton. Hybrid electric drive – enhancing energy security. In *Maritime Sys-*