

Control and optimization of a large scale refinery hydrogen network

Y.K. Lee* , H.K. Park* , C.H. Jeong* ,
J.R. Lee , B.J. Minter , S.G. Goodhart**

*Sk energy, Ulsan, South Korea (e-mail: yklee@skenergy.com, hkpark@skenergy.com, dgc3hyg@skenergy.com) ** Applied Manufacturing Technologies (e-mail: jr.lee@applied-mt.com, brendan.minter@applied-mt.com, sean.goodhart@applied-mt.com)

Abstract: Modern refineries must produce large quantities of high quality low sulfur fuels for today's market. A significant input to the low sulfur fuels manufacturing process is hydrogen, which is both produced and consumed within the refinery. When insufficient hydrogen is available, production rates will fall, having significant financial penalties on refinery operation. If excess hydrogen is produced then it must be downgraded to fuel or potentially flared, having a negative environmental impact. Balancing hydrogen production and distribution in the refinery to match rapidly changing demands represents a significant benefit in terms of cost of operation.

1. INTRODUCTION

Modern refineries must produce large quantities of high quality low sulfur fuels for today's market. A significant input to the low sulfur fuels manufacturing process is hydrogen, which is both produced and consumed within the refinery. When insufficient hydrogen is available, production rates will fall, having significant financial penalties on refinery operation. If excess hydrogen is produced then it must be downgraded to fuel or potentially flared, having a negative environmental impact. Balancing hydrogen production and distribution in the refinery to match rapidly changing demands represents a significant benefit in terms of cost of operation.

SK and AMT have implemented an advanced control system in the SK Ulsan Refinery Complex, which coordinates hydrogen production across two interconnected hydrogen networks. The control system sets hydrogen production in two hydrogen reformers, manipulates the flows of purified hydrogen rich off-gas streams from three aromatic reformers and manipulates the transfer line flows between the two hydrogen networks to balance production with demand. The system has been developed using commercially available multivariable control software but required considerable technical effort for success:

Significant changes to the regulatory control schemes in the hydrogen reformers, rich gas producers and some of the largest hydrogen users,
Tight coordination of plant testing with hydrogen user needs using semi-automated plant testing,
Creation of accurate plant/network models,
Changing network handles in the multivariable controller as hydrogen balance changes throughout the refinery result in the need to adapt active manipulated and controlled variables.

This short paper will describe in detail the project, the technical solution and the benefits achieved.

2. HYDROGEN NETWORK CONTROL?

SK Ulsan Refinery Complex Hydrogen Network consists two reformers and 3 PSA to product high purity hydrogen and 3 PSA are taking low purity hydrogen as a feed. (Fig. 1)

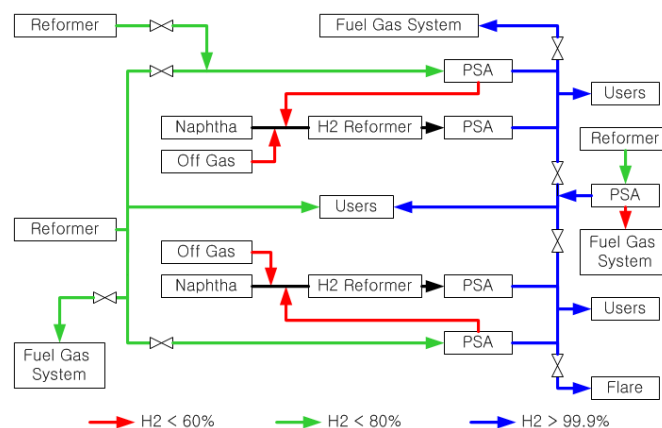

Fig.1 SK Ulsan Refinery Hydrogen Network

In order to meet and balance the rapidly changing demand, hydrogen reformer should move neither a step ahead nor a step behind. How to indicate when hydrogen reformer need to change its load is watching its hydrogen header pressure because when the demand is increased causes their hydrogen makeup suction pressure is falling and hydrogen header pressure is falling at a same time. If hydrogen reformer can balance its header pressure tight and steady, that means hydrogen production and demand is balanced.

3. REGULATORY CONTROLLER MODIFICATION

3.1. Hydrogen Reformer COT Controller

Hydrogen reformer which designed by HARDOR TOPSEO doesn't have reformer coil outlet temperature controller –

COT. The coil outlet temperature's response has high order transfer function of gasified hydrocarbon, steam and fuel that 80% of fuel gas is the recycled tail gas from its own PSA and 20% of fuel gas should be set by COT controller. In addition, PSA tail gas pressure controller tends to be in MAN Mode because tail gas PC controller in PSA cannot be adjusted according to production changes online and it goes easily sluggish or precipitous by nonlinearized valve characteristic.

We have stepped reformed coil outlet temperature and implemented a COT Controller as a simplified model-based feed-forward function with gain multiplier block. (Fig.2) and it can control Methane in Effluent of reformer tighter (40% standard deviation improved) (Fig.3)

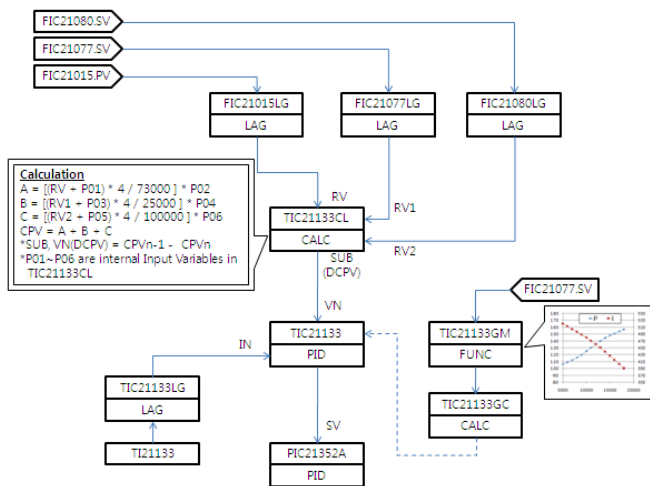

Fig.2 COT Configuration

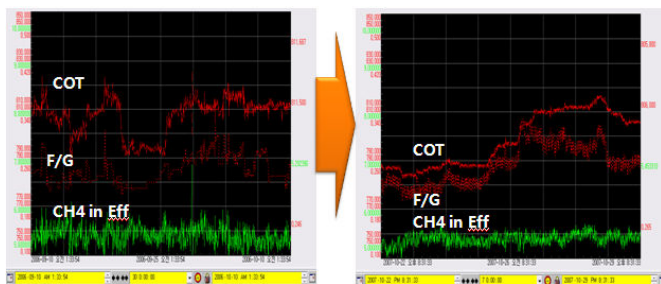

Fig.3 COT and Methane in Effluent Control Performance

3.2. Hydrogen Reformer Draft Controller

IDF and FDF damper was designed to be set by IDF and FDF Pressure controller but hasn't been used more than 8 years after one of reformer heater was trip by the PC controllers malfunction from the VVVF (Variable Voltage Variable Frequency) controller. We reconfigured the draft controller sets IDF damper and installed new flow controller in FDF to be set by APC to control excess O2 in the stack. (Fig.4) It was not easy to overcome the resistance of operation team.

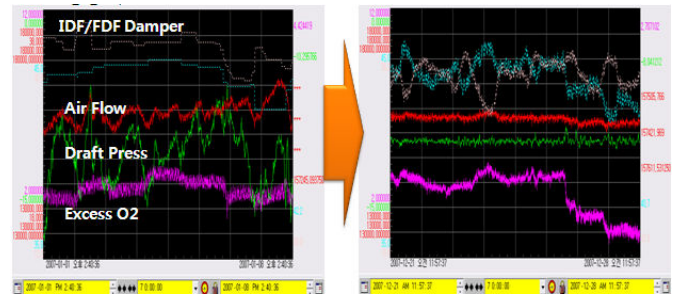

Fig.4. Draft Controller Performance

3.3. Hydrogen Feed Controller

Hydrogen reformer has been revamped several times to attach new feeds since it had been built. A single loop of feed controller takes more than 30 min to stabilize with the disturbances not only reformer feed's change but alternative feed flow's change. We put feed-forward control function in that feed controller so that move with feed-forward action when disturbance occurs. (Fig 5)

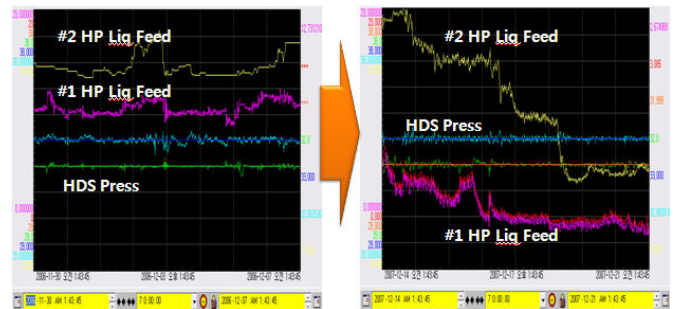

Fig.5 Feed Control Performance

4. HYDROGEN HEADER PRESSURE MODELING

When we have tried to model this network, we have faced typical problem in the gas phase pressure control. Hydrogen header pressure is changing back and forth from the integrating model to self-balancing model. While the network has connected with more than 20 processes, 30% of the related regulatory controllers are not in the normal mode – AUTO or CAS - not only hydrogen reformer itself but also network transfer flow controllers and these hidden abnormal operating controllers diminish the integrating effect in the network and change the model into self-balancing model.

4.1 Network Transfer Flow Controllers

There were two type of problems in the network transfer flow controllers. One, its engineering design and installation had not consider the network connection – redundant, infeasible and conflicting controllers. Two, sharing hydrogen flow controllers should be set by scheduling or manage system but those flow controller are stronger handle for the hydrogen header pressure so that operation tends to move those first instead of hydrogen reformer and it makes transfer flow controllers had been saturated 75% of run time when demand flow is over-set than it can take.

We have categorized two groups of network controllers, normal AUTO mode controllers and normal MAN mode controllers. AUTO-mode-desired controllers are modified to be run in operable range by changing control scheme and installing a throttle valve and MAN-mode-desired controllers are remained program-AUTO as being set by APC to be saturated all the time with setpoint keep changing.

4.2 Hydrogen Makeup Controller Scheme Modification

Some hydrogen consumer unit's hydrogen makeup controllers that can take two different hydrogen from two network are designed without considering the network. Designed controller is taking low purity hydrogen by pressure controller but that header is always little margin and it causes operator put that valve in MAN all the time and transfer process dynamic response through the valve from header to header. We have installed new flow controller that can take a designated amount of flow from the low purity hydrogen and break the dynamic response within headers.(Fig.6)

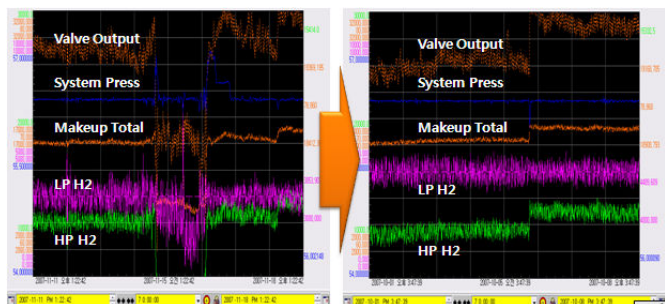

Fig. 6 Hydrogen Makeup stabilization

4.3 Semi-Automated Plant Testing

We planned to use automated plant testing program but the integrating response and too many disturbance made automated plant testing program always in correction mode to balance the network. More than two engineers have been to be in the different control rooms to hold the operators move the plant at a same time until we see the response without process upset. Usually disturbances impact into the network more than one MV's move so that MV's move size negotiation was critical path for the step test. MV's move size was set by the response of the network after one or two moves first.

5. NETWORK OPERATION STRATEGY

5.1 Balancing Strategy

We put a strategy to control hydrogen network : Hydrogen reformer should be the same load. Overall the network can be assumed as a one network, but always each hydrogen reformer can backup a separated network when some incident happened.

5.2 Feed Selecting by The Quality

Three low purity hydrogen are the candidate for the feed instead of liquid feed - naphtha, LSR and C4. We evaluate each streams quality to measure the price of the stream and sort the cost of feed streams to push more and cut less when liquid feed is to be cut or push more.

6. RESULT AND BENEFIT

Benefits are measured two viewpoints.

One. How much high purity hydrogen loss to fuel gas or flare is minimized by decreasing its valve opening? (Fig 7)

Second, How much low purity hydrogen loss to fuel gas is minimized by decreasing its valve opening which is set by pressure controller? (Fig 8)

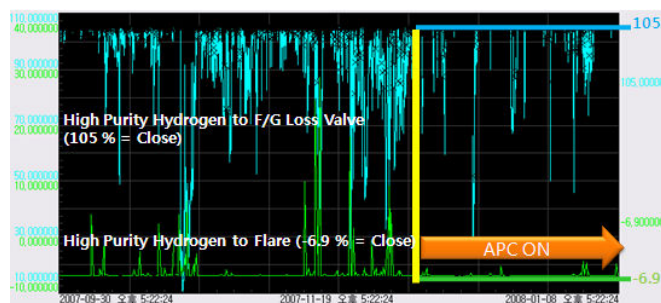

Fig.7 High Purity Hydrogen Loss Minimization

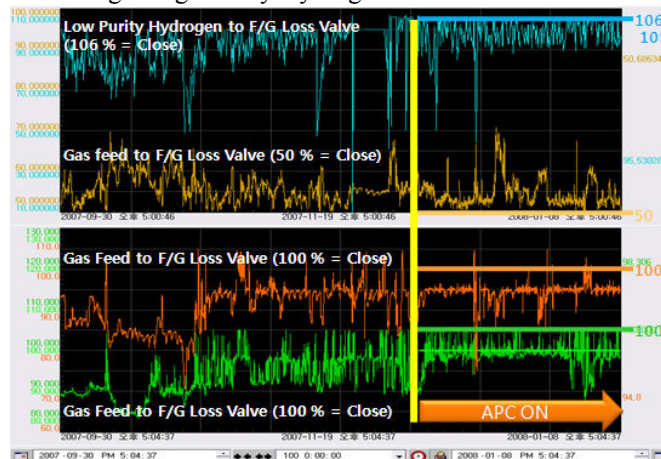

Fig.8 Low Purity Hydrogen Loss Minimization

With balancing the network, we has swapped low price feed for liquid feed more than 10% of total reformer load and its benefit is over 300,000USD a year.