

Improving transient behavior of MIMO adaptive systems [★]

Marcos F. D. Pinto ^{*} Ramon R. Costa ^{**}

^{*} IPqM - Navy Research Institute, Rio de Janeiro, BRAZIL
(e-mail: mpinto@ipqm.mar.mil.br)

^{**} COPPE/UFRJ - Department of Electrical Engineering, Rio de Janeiro, BRAZIL (e-mail: ramon@coep.ufrj.br)

Abstract: This paper presents a model-reference adaptive control algorithm with improved transient behavior for MIMO uncertain plants with relative degree one. The algorithm employs the control parametrization based on the SDU factorization of the high frequency gain matrix and introduces a lead filter in the adaptive law. Using the singular perturbation method, it is shown that for a sufficiently high adaptation gain and a sufficiently small time constant of the filter, the output error decreases exponentially. Simulations illustrate the transient improvement attained with the algorithm.

Keywords: Adaptive control, transient performance, stability, singular perturbation.

1. INTRODUCTION

Over the last years a considerable amount of effort has been devoted to improve the poor transient behavior of adaptive control systems. Some results can be found in, for example, (Sun (1993)), (Datta and Ioannou (1994)), (Datta and Ho (1994)), (Papadakis and Thomopoulos (1996)), (Zang and Bitmead (1994)), (Ortega et al. (1994)), (Narendra and Balakrishnan (1994)), (Artega and Tang (2002)), (Dixon et al. (2004)). In (Cao and Hovakimyan (2006a)), (Cao and Hovakimyan (2006b)), (Cao and Hovakimyan (2007a)) and (Cao and Hovakimyan (2007b)) one can find some of the most recent results in this area. However, even after all these efforts, a methodology focused on improving the transient behavior in the case of MIMO adaptive systems is still lacking in the literature.

This paper presents a generalization of the adaptive algorithm introduced in (Costa (1999)) for MIMO linear systems with relative degree one. The MIMO framework is based on the design proposed by (Costa et al. (2003)) which employs a control parametrization derived from an SDU factorization of the high frequency gain matrix. The algorithm presented here employs a lead-filter to estimate the tracking error derivative and uses this signal in the update law. It is shown that the system stability does not depend on the filter parameters. Moreover, if the adaptation gain is sufficiently high and the filter time constant is sufficiently small, then the transient behavior is approximately exponentially decreasing with a rate of convergence that depends only on the design parameters. The improvement in the transient performance is concluded from an analysis based on the standard *singular perturbation method* (Kokotović et al. (1986)) (Khalil (1992)).

[★] This work was supported in part by the CNPq/Brazil.

Some simulation results are presented to illustrate the improvement achieved in the transient behavior by the proposed adaptive algorithm.

2. PROBLEM STATEMENT

For an observable and controllable MIMO linear time-invariant plant given by $m \times m$ transfer matrix $G(s)$,

$$y = G(s)u, \quad (1)$$

we make the following assumptions (Costa et al. (2003)):

- (A1) The transmission zeros of $G(s)$ have negative real parts.
- (A2) $G(s)$ has relative degree $n^* = 1$.
- (A3) The observability index ν of $G(s)$ is known.
- (A4) The signs of the leading principal minors of the plant high frequency gain (HFG) matrix K_p are known.

The adaptive control objective is to achieve asymptotic tracking

$$e_0(t) = y(t) - y_M(t) \rightarrow 0 \quad \text{as } t \rightarrow \infty, \quad (2)$$

where $y_M \in \mathbb{R}^m$ is the output of the reference model

$$y_M = W_M(s)r, \quad (3)$$

and $r \in \mathbb{R}^m$ is a piecewise continuous uniformly bounded signal.

In view of assumption (A2), we select a diagonal *strictly positive real* (SPR) reference model

$$W_M(s) = K_M \text{diag} \left\{ \frac{1}{s+a_1}, \dots, \frac{1}{s+a_m} \right\}, \quad (4)$$

where $a_i > 0$, ($i = 1, \dots, m$). Without loss of generality, we let $K_M = I$.

3. SYSTEM ERROR EQUATIONS

If $G(s)$ is known, then a control law which achieves matching between the closed-loop transfer matrix and

$W_M(s)$, i.e. $y = G(s)u^* = W_M(s)r = y_M$, is given by (Sastry and Bodson (1989))

$$u^* = \theta_1^{*T} \omega_1 + \theta_2^{*T} \omega_2 + \theta_3^* y + \theta_4^* r = \theta^{*T} \omega, \quad (5)$$

where $\theta^* = [\theta_1^{*T} \theta_2^{*T} \theta_3^* \theta_4^*]^T$ and the regressor vector $\omega = [\omega_1^T \omega_2^T y^T r^T]^T$ with

$$\theta_1^*, \theta_2^* \in \mathbb{R}^{m(\nu-1) \times m}, \theta_3^* \in \mathbb{R}^{m \times m}, \theta_4^* = K_M K_p^{-1},$$

$$\omega_1 = \frac{A(s)}{\Lambda(s)} u, \omega_2 = \frac{A(s)}{\Lambda(s)} y, \quad \omega_1, \omega_2 \in \mathbb{R}^{m(\nu-1)},$$

$$A(s) = [I \quad Is \quad \dots \quad Is^{\nu-2}]^T, \quad I \in \mathbb{R}^{m \times m},$$

$$\Lambda(s) = \lambda_0 + \lambda_1 s + \dots + s^{\nu-1} \text{ is Hurwitz.}$$

Details on the calculation of the matching parameters θ_1^*, θ_2^* and θ_3^* can be found in (Tao (2003), p:391). The matched closed-loop system is obtained setting $u = u^*$. After some algebraic manipulation, the output error equation can be written as (Tao (2003))

$$e_0 = W_M(s)K_p [u - \theta^{*T} \omega]. \quad (6)$$

Except for the fact that $W_M(s)$ and K_p are matrices and e and u are vectors, this MIMO error equation has the same form as the well known SISO error equation. Another important difference to be observed is the non-uniqueness of θ^* in the MIMO case.

4. REVIEW OF MIMO MRAC DESIGN

In this section we review the MIMO MRAC design proposed by (Costa et al. (2003)). The algorithm employs a control parametrization derived from an *SDU* factorization of the matrix K_p .

4.1 Gain factorization

The following lemma was adapted from (Morse (1993)).

Lemma 1. Every $m \times m$ real matrix K_p with nonzero lead principal minors $\Delta_1, \Delta_2, \dots, \Delta_m$ can be factored as

$$K_p = SDU, \quad (7)$$

where S is symmetric positive definite, D is diagonal, and U is unity upper triangular.

Proof: Since all Δ_i are nonzero, there exists a unique factorization (Strang (1988)),

$$K_p = L_1 D_p L_2^T, \quad (8)$$

where L_1 and L_2 are unity lower triangular and

$$D_p = \text{diag} \left\{ \Delta_1, \frac{\Delta_2}{\Delta_1}, \dots, \frac{\Delta_m}{\Delta_{m-1}} \right\}. \quad (9)$$

Factoring D_p as

$$D_p = D_+ D, \quad (10)$$

where D_+ is a diagonal matrix with positive entries, we rewrite (8) as $K_p = L_1 D_+ L_1^T L_1^{-T} D L_2^T$, so that (7) is satisfied by $S = L_1 D_+ L_1^T$ and $U = D^{-1} L_1^{-T} D L_2^T$. ■

Remark: In (Morse (1993)), the matrix D is made of diagonal entries $+1$ or -1 . Here, the factorization $K_p = SDU$ is not unique because the positive diagonal matrix D_+ , introduced in (10), is a free parameter.

4.2 Control parametrization

Substituting $K_p = SDU$ in the error equation (6) and using (5) one obtains

$$\begin{aligned} e_0 &= W_M(s)SDU[u - \theta^{*T} \omega] \\ &= W_M(s)SD[Uu - U\theta_1^{*T} \omega_1 - U\theta_2^{*T} \omega_2 - U\theta_3^* y - U\theta_4^* r]. \end{aligned} \quad (11)$$

A further refinement of this expression will make sure that the control law is well-defined. With the decomposition,

$$Uu = u - (I - U)u, \quad (12)$$

where $(I - U)$ is strictly upper triangular, it is possible to define the control signal u as a function of $(I - U)u$. No static loops can appear since u_1 would depend on u_2, u_3, \dots, u_m , while u_2 would depend on u_3, u_4, \dots, u_m , and so on. The unknown entries of U are incorporated in the parametrization by defining $K_1 = U\theta_1^{*T}$, $K_2 = U\theta_2^{*T}$, $K_3 = U\theta_3^*$, and $K_4 = U\theta_4^*$, and rewriting (11) as

$$e_0 = W_M(s)SD[u - K_1 \omega_1 - K_2 \omega_2 - K_3 y - K_4 r - (I - U)u]. \quad (13)$$

Next, the parameter vectors Θ_i^* are introduced via the identity

$$\begin{bmatrix} \Theta_1^{*T} \Omega_1 \\ \Theta_2^{*T} \Omega_2 \\ \vdots \\ \Theta_m^{*T} \Omega_m \end{bmatrix} \equiv K_1 \omega_1 + K_2 \omega_2 + K_3 y + K_4 r + (I - U)u. \quad (14)$$

In addition to the concatenated i^{th} rows of the matrices K_1, K_2, K_3, K_4 , each row Θ_i^{*T} includes the unknown entries of the i^{th} row of $(I - U)$. The corresponding regressor vectors are

$$\begin{aligned} \Omega_1^T &= [w^T \quad u_2 \quad u_3 \quad \dots \quad u_m], \\ \Omega_2^T &= [w^T \quad u_3 \quad \dots \quad u_m], \\ &\vdots \\ \Omega_m^T &= [w^T]. \end{aligned} \quad (15)$$

To simplify the notation, it is also defined

$$\Omega^T = \begin{bmatrix} \Omega_1^T & 0 & 0 & \dots & 0 \\ 0 & \Omega_2^T & 0 & \dots & 0 \\ \vdots & \vdots & \vdots & \ddots & \vdots \\ 0 & 0 & 0 & \dots & \Omega_m^T \end{bmatrix} \quad \text{and} \quad \Theta^* = \begin{bmatrix} \Theta_1^* \\ \Theta_2^* \\ \vdots \\ \Theta_m^* \end{bmatrix}. \quad (16)$$

The error equation (13) has thus been brought to the form,

$$e_0 = (W_M(s)S) D (u - \Omega^T \Theta^*). \quad (17)$$

In this parametrization the control law is

$$u = \Omega^T \Theta, \quad (18)$$

where Θ is an estimate of Θ^* . The key feature of the error equation (17) is that the diagonal matrix D appears in the place of the K_p , and an assumption can now be made about the signs of its entries d_1, d_2, \dots, d_m , generalizing the sign condition of the SISO case. Although an increase of apriori system plant information is required, it results in a simpler MRAC design for a MIMO case. This parametrization requires that the *SPR* condition is to be satisfied by $W_M(s)S$ rather than by $W_M(s)$ alone. The following lemma shows that for any diagonal $W_M(s)$, a positive definite $S = S^T$ exists such that $W_M(s)S$ is *SPR*.

Lemma 2. For any $A = \text{diag}\{-a_1, -a_2, \dots, -a_m\}$, $a_i > 0$, ($i = 1, \dots, m$), and any $m \times m$ unity lower triangular matrix L_1 , there is a matrix $D_+ = \text{diag}\{d_1^+, d_2^+, \dots, d_m^+\}$, $d_i^+ > 0$, such that $W_M(s)S = (sI - A)^{-1}L_1D_+L_1^T$ is *SPR*.

Proof. See (Costa et al. (2003)). The proof uses the fact that S in $K_p = SDU$ is not unique.

Remark: The SDU approach intrinsically introduces $m(\frac{m-1}{2})$ additional adaptive parameters which lead to an MRAC scheme with overparametrization.

4.3 Adaptive Control

Define the state vector $X = [x^T \ w_1^T \ w_2^T]^T \in \mathbb{R}^{n+2m(\nu-1)}$, where $x \in \mathbb{R}^n$ is the plant state and w_1 and w_2 are the states of the filters used to generate the regressor. With X_M we denote the state of a corresponding nonminimal realization $C_M(sI - A_M)^{-1}B_M$ of $W_M(s)S$, where $C_M B_M = S$. Then, the state error

$$Z = X - X_M, \quad (19)$$

and the output error e_0 in (17) satisfies

$$\begin{aligned} \dot{Z} &= A_M Z + B_M D(u - \Omega^T \Theta^*), \\ e_0 &= C_M Z. \end{aligned} \quad (20)$$

Because $W_M(s)S$ is *SPR*, there exist matrices $P_M = P_M^T > 0$ and $Q_M = Q_M^T > 0$ that satisfies

$$\begin{aligned} A_M^T P_M + P_M A_M &= -2Q_M, \\ P_M B_M &= C_M^T. \end{aligned} \quad (21)$$

Define matrices

$$D = \text{diag}\{d_1 I_1, d_2 I_2, \dots, d_m I_m\}, \quad (22)$$

$$\Gamma = \text{diag}\{\Gamma_1, \Gamma_2, \dots, \Gamma_m\}, \quad (23)$$

where d_i are the diagonal elements of matrix D , $\Gamma_i = \Gamma_i^T > 0$ are adaptation gain matrices, and I_i and $\Gamma_i \in \mathbb{R}^{(2n+m-i) \times (2n+m-i)}$. Also define

$$\tilde{\Theta} = \Theta - \Theta^* \quad \text{and} \quad \tilde{u} = u - u^*. \quad (24)$$

Now, consider the Lyapunov function

$$2V(Z, \tilde{\Theta}) = Z^T P_M Z + \tilde{\Theta}^T |\mathcal{D}| \Gamma^{-1} \tilde{\Theta}. \quad (25)$$

Since $D\Omega^T = \Omega^T \mathcal{D}$, then the time derivative of (25) along the trajectories of the error system (20) yields

$$\begin{aligned} \dot{V}(Z, \tilde{\Theta}) &= -Z^T Q_M Z + \tilde{\Theta}^T \mathcal{D} \Omega e_0 + \tilde{\Theta}^T |\mathcal{D}| \Gamma^{-1} \dot{\tilde{\Theta}} \\ &= -Z^T Q_M Z + \tilde{\Theta}^T |\mathcal{D}| \Gamma^{-1} [\Gamma \text{sign}(\mathcal{D}) \Omega e_0 + \dot{\tilde{\Theta}}]. \end{aligned} \quad (26)$$

Choosing

$$\dot{\tilde{\Theta}} = -\Gamma \text{sign}(\mathcal{D}) \Omega e_0, \quad (27)$$

the expression for \dot{V} reduces to

$$\dot{V}(Z, \tilde{\Theta}) = -Z^T Q_M Z \leq 0. \quad (28)$$

The result of the above analysis can be summarized in the following theorem.

Theorem 3. Consider system in (1) and the reference model (3). Suppose that assumptions (A1)-(A4) hold. If the vector $r(t)$ is piecewise continuous and uniformly bounded, then the adaptive control (18) with update law (27) assures that all the closed loop signals are uniformly bounded and the tracking error vector $e_0(t) \rightarrow 0$.

Proof. See (Costa et al. (2003)).

5. MODIFIED MIMO ADAPTIVE ALGORITHM

In this section, we extend the adaptive algorithm introduced in (Costa (1999)) to the MIMO case and show its stability and transient performance. The new algorithm is referred to as MIMO α -MRAC. It employs a lead-filter to estimate the derivative of e_0 and uses this signal in the update law. For a sufficiently high adaptation gain and a sufficiently small time constant of the filter, it is shown that the transient behavior is approximately exponentially decreasing with a rate of convergence that depends only on the design parameters.

To introduce the main idea, suppose that \dot{e}_0 is available for measurement. From the equation error

$$\begin{aligned} e_0 &= W_M(s)SD[u - \Omega^T \Theta^*] \\ &= W_M(s)SD\Omega^T \tilde{\Theta}, \end{aligned} \quad (29)$$

one can compute the signal F (see Costa (1999))

$$F := W_M(s)^{-1}e_0 = SD\Omega^T \tilde{\Theta}. \quad (30)$$

In other words, the signal F , which is a measure of $SD\Omega^T \tilde{\Theta}$, can be computed as

$$F = \dot{e}_0 - Ae_0. \quad (31)$$

Consider the Lyapunov function (25) and its derivative (26). Now, we propose to modify the update law (27) as

$$\dot{\tilde{\Theta}} = -\Gamma \text{sign}(\mathcal{D})\Omega[e_0 + \alpha F], \quad (32)$$

where α is a positive constant. This way, instead of forcing a cancelation, the proposed update law (32) keeps the $\tilde{\Theta}$ -term in the expression of \dot{V} by completing the square as follows,

$$\dot{V}(Z, \tilde{\Theta}) = -Z^T Q_M Z - \alpha(\Omega^T \tilde{\Theta})^T DSD(\Omega^T \tilde{\Theta}). \quad (33)$$

Since $DSD > 0$, then $\dot{V} \leq 0$.

Therefore, the update law (32) guarantees that the system is *at least globally uniformly stable*.

When \dot{e}_0 is not available then the signal F cannot be computed as in (31). To circumvent this problem we use an estimate \hat{e}_0 ,

$$\hat{e}_0 = I \left(\frac{s}{\tau s + 1} \right) e_0 = sT(s)e_0, \quad (34)$$

where τ is a positive time constant and $T(s) = I \left(\frac{1}{\tau s + 1} \right)$. Replacing e_0 in (30) by its estimate \hat{e}_0 we obtain an estimate \hat{F} of F as,

$$\hat{F} = W_M(s)^{-1}\hat{e}_0 = W_M(s)^{-1}T(s)e_0 = H(s)e_0, \quad (35)$$

where $H(s)$ is a diagonal matrix of lead filters.

Now, using (35), the update law is modified to

$$\dot{\tilde{\Theta}} = -\Gamma \text{sign}(\mathcal{D})\Omega[e_0 + \alpha \hat{F}]. \quad (36)$$

Figure 1 shows the block diagram of the MIMO α -MRAC.

6. STABILITY ANALYSIS

The expression (35) for \hat{F} can be written as

$$\begin{aligned} \hat{F} &= T(s)F \\ &= T(s)SD\Omega^T \tilde{\Theta}. \end{aligned} \quad (37)$$

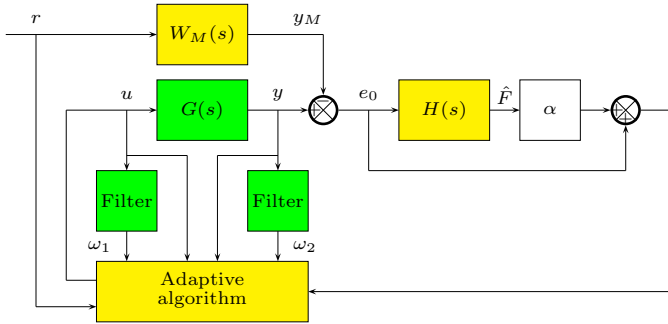

Fig. 1. Block diagram of the MIMO α -MRAC.

To simplify the notation we define

$$\mathcal{F} = D\Omega^T\tilde{\Theta}. \quad (38)$$

Defining the state vector (see (Costa (1999)))

$$v = [\hat{e}_0^T \ Z^T]^T, \quad v \in \mathbb{R}^{n+m(2\nu-1)}, \quad (39)$$

we have the following nonminimal realization for (37),

$$\begin{aligned} \dot{v} &= \bar{A}v + \bar{B}\mathcal{F}, \\ \hat{F} &= \bar{C}v, \end{aligned} \quad (40)$$

where \bar{A} , \bar{B} , \bar{C} are given by

$$\begin{aligned} \bar{A} &= \begin{bmatrix} -\tau^{-1}I & \tau^{-1}C_M \\ 0 & A_M \end{bmatrix}, \quad \bar{B} = \begin{bmatrix} 0 \\ B_M \end{bmatrix}, \\ \bar{C} &= [(-A - \tau^{-1}I) \ \tau^{-1}C_M]. \end{aligned}$$

The state equation (40) is introduced only for analysis. Since \mathcal{F} is not available, it cannot be implemented. Since $T(s)S$ is strictly positive real, then from Kalman Meyer Yakubovich Lemma there exist matrices $\bar{P} = \bar{P}^T > 0$ and $\bar{Q} = \bar{Q}^T > 0$ such that the realization $\{\bar{A}, \bar{B}, \bar{C}\}$ satisfies

$$\begin{aligned} \bar{A}^T\bar{P} + \bar{P}\bar{A} &= -2\bar{Q}, \\ \bar{P}\bar{B} &= \bar{C}^T. \end{aligned} \quad (41)$$

For convenience, we rewrite below the set of equations that represents the system dynamics,

$$\dot{Z} = A_M Z + B_M \mathcal{F}, \quad (42)$$

$$e_0 = C_M Z, \quad (43)$$

$$\dot{v} = \bar{A}v + \bar{B}\mathcal{F}, \quad (44)$$

$$\hat{F} = \bar{C}v, \quad (45)$$

$$\dot{\tilde{\Theta}} = -\Gamma \text{sign}(\mathcal{D})\Omega[e_0 + \alpha\hat{F}]. \quad (46)$$

Now, consider the Lyapunov function

$$2V(Z, v, \tilde{\Theta}) = Z^T P_M Z + \alpha v^T \bar{P} v + \tilde{\Theta}^T |\mathcal{D}| \Gamma^{-1} \tilde{\Theta}. \quad (47)$$

Using (41), the derivative of (47) along the trajectories of (42)-(46) results

$$\dot{V}(Z, v, \tilde{\Theta}) = -Z^T Q_M Z - \alpha v^T \bar{Q} v. \quad (48)$$

Since, $\dot{V}(Z, v, \tilde{\Theta}) \leq 0$, it implies that $V(Z, v, \tilde{\Theta})$ is nonincreasing along trajectories (42)-(46) in the $(Z, v, \tilde{\Theta})$ -space. Thus, $V(Z, v, \tilde{\Theta})$ is bounded above by $V(0)$ and below by 0 and $Z, v, \tilde{\Theta}$ are bounded. Since the reference $r(t)$ and y_M are bounded, consequently y is bounded. Now, since Θ^* is a constant and $\tilde{\Theta}$ is bounded, it implies that Θ is also bounded. Moreover, because r and y are bounded,

it can be shown in a recursive way as in (Costa et al. (2003)) that the regressor matrix Ω is bounded. Thus, from (42) and (44), it follows that \dot{Z} and \dot{v} are bounded and consequently \dot{V} is also bounded. From (30) it follows that F is bounded. From (46) one concludes that $\dot{\tilde{\Theta}}$ is bounded. Now, applying the Barbalat's Lemma, it follows that $Z, v \rightarrow 0$ when $t \rightarrow \infty$.

The following theorem summarizes the result.

Theorem 4. : Consider system (1) and the reference model (3). Suppose that assumptions (A1)-(A4) hold. If $r(t)$ is piecewise continuous and uniformly bounded, then the adaptive control (18) with update law (36) assure that all the closed loop signals are uniformly bounded and the tracking error vector $e_0(t) \rightarrow 0$.

Notice that $\lim_{t \rightarrow \infty} v = 0$ implies that $\lim_{t \rightarrow \infty} \hat{F} = 0$. It can also be verified that

$$\lim_{t \rightarrow \infty} F = 0 \quad \text{and} \quad \lim_{t \rightarrow \infty} \Omega^T \tilde{\Theta} = 0. \quad (49)$$

From (49) we conclude that $\tilde{u} \rightarrow 0$ without identification of the matching vector parameters and without any persistency excitation or richness condition.

7. TRANSIENT ANALYSIS

It was shown that the system (42)-(46) is globally stable for all time constant $\tau > 0$, $\alpha > 0$ and adaptation gain matrix $\Gamma = \Gamma^T > 0$. To analyse the transient behavior of the nonlinear MIMO system in (42)-(46) we use the *singular perturbations method* (Kokotović et al. (1986)). The purpose is to find a reduced model for the system dynamics and to analyse its transient behavior.

7.1 Reduced model

Consider the equations (31), (36) and (??). Rewriting them in a convenient form to apply the singular perturbation method we have,

$$\dot{e}_0 = Ae_0 + F, \quad (50)$$

$$\tau \dot{\hat{F}} = -\hat{F} + F, \quad (51)$$

$$\Gamma^{-1} \dot{\tilde{\Theta}} = -\text{sign}(\mathcal{D})\Omega[e_0 + \alpha\hat{F}]. \quad (52)$$

Now, considering τ and Γ^{-1} as the *singular parameters*, and formally setting $\tau = 0$ and $\Gamma^{-1} = 0$, and disregarding the initial conditions for $\tilde{\Theta}$ and \hat{F} , the differential equations (51) and (52) degenerate into the algebraic equations (see Kokotović et al. (1986))

$$0 = -\bar{\hat{F}} + \bar{F}, \quad (53)$$

$$0 = \bar{e}_0 + \alpha\bar{\hat{F}}, \quad (54)$$

where the bar indicates that the variables belong to a reduced order system (with $\tau = 0$ and $\Gamma^{-1} = 0$). Notice that both τ and Γ^{-1} should be considered as *singular parameters*. This way, the algebraic equations (53)-(54) have a *isolated real root* given by

$$\bar{F} = -\alpha^{-1}\bar{e}_0. \quad (55)$$

Upon substituting (55) into (50), we have that

$$\dot{\bar{e}}_0 = (A - \alpha^{-1}I)\bar{e}_0. \quad (56)$$

Defining $\bar{A} = (A - \alpha^{-1}I)$, we rewrite the system reduced order model (56) as

$$\dot{\bar{e}}_0 = \bar{A}\bar{e}_0, \quad (57)$$

which has solution given by

$$\bar{e}_0 = e^{\bar{A}t}\bar{e}_0(0). \quad (58)$$

Thus, for a sufficiently high adaptation gain Γ and sufficiently small time constant τ , the tracking error e_0 (approximately) converges exponentially fast to zero.

8. SIMULATION RESULTS

In the first example we consider the plant $G_1(s) = K_p \text{diag} \left\{ \frac{1}{s+1}, \frac{1}{s+1} \right\}$, where $K_p = \begin{bmatrix} 0.5 & 0.866 \\ -0.866 & 0.5 \end{bmatrix}$ is the only unknown, and the reference model $W_M(s) = \text{diag} \left\{ \frac{1}{s+1}, \frac{1}{s+1} \right\}$. For comparison purpose Fig. 2 presents the simulation results obtained when the MIMO standard-MRAC (Costa et al. (2003)) is used. Fig. 3 shows the corresponding plots obtained with the proposed α -MRAC algorithm. The data used in this simulations are: $\Gamma = 5I$, $\tau = 0.1$, $\alpha = 1$, $r(t) = [\sin(3t) \quad \sin(5.5t)]^T$, $y(0) = \hat{e}_0(0) = [2.7 \quad -0.7]^T$. All other initial conditions are zero. As predicted in the above analysis, the improvement in the transient behavior is apparent in Fig. 3(a), even for the values of Γ and τ used.

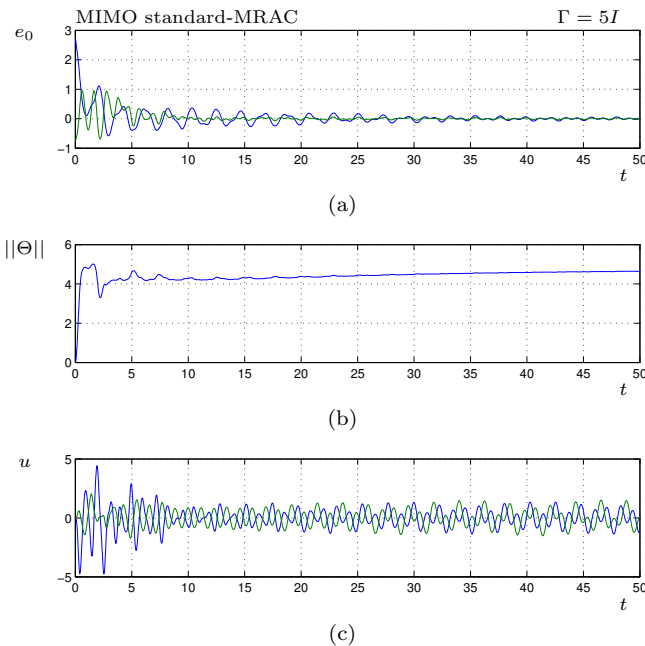

Fig. 2. Simulation of plant $G_1(s)$ using the MIMO standard-MRAC.

As our second example, we consider the plant $G_2(s) = K_p \text{diag} \left\{ \frac{(s+6)}{s(s+2)}, \frac{(s+6)}{s(s+3)} \right\}$, where K_p is as in the first example and the reference model is $W_M(s) = \text{diag} \left\{ \frac{1}{s+1}, \frac{1}{s+2} \right\}$.

The results from simulations carried out using the MIMO standard-MRAC are shown in Fig. 4 and using the proposed MIMO α -MRAC are shown in Fig. 5. The following data were used: $\Gamma = 10I$, $\alpha = 1$, $\tau = 0.05$, $r(t) =$

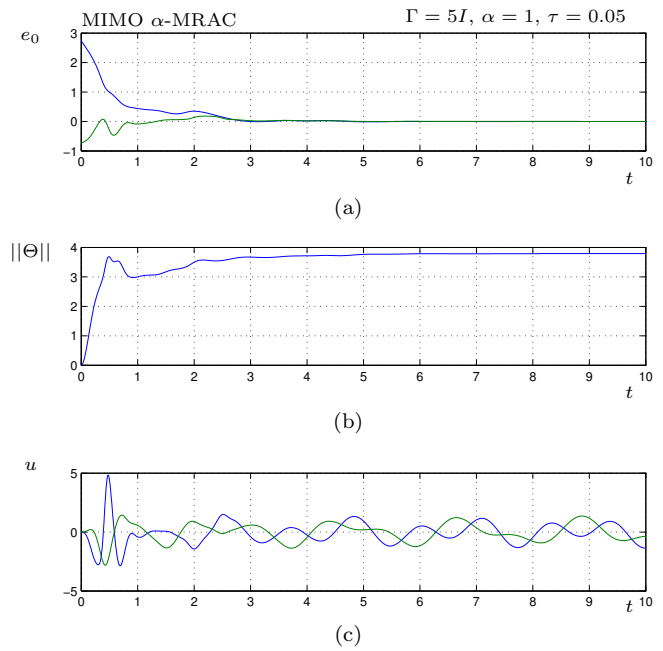

Fig. 3. Simulation of plant $G_1(s)$ using the MIMO α -MRAC.

$[\sin(1.1t) \quad -\sin(6t)]^T$, $y(0) = \hat{e}_0(0) = [0.956 \quad -0.256]^T$. All other initial conditions are zero.

The plots in Fig. 5 show a notable improvement in transient behavior compared to the response obtained with the MIMO standard-MRAC.

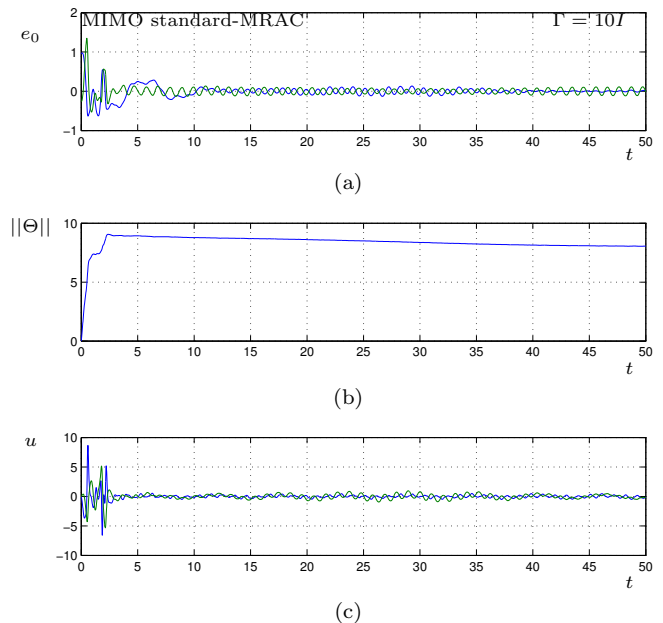

Fig. 4. Simulation results of plant $G_2(s)$ using MIMO standard-MRAC.

9. CONCLUSION

In this paper we have presented a MRAC scheme for MIMO systems, named MIMO α -MRAC, and analyzed its stability and transient behavior. The main result states that, if the adaptation gain is set sufficiently high and the filter time constant is set sufficiently small, then the

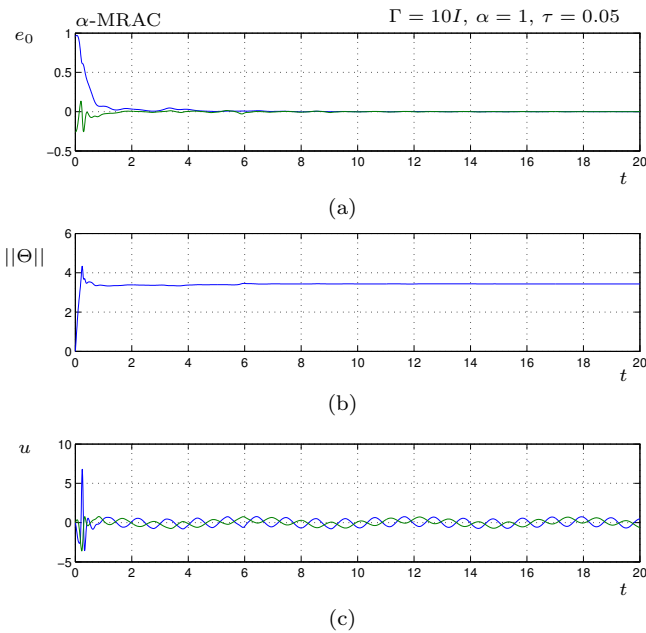

Fig. 5. Simulation results of plant $G_2(s)$ using MIMO α -MRAC.

initial tracking error and the mismatch control decrease (monotonically) exponentially with a rate that is dictated by the design parameters. Moreover, the transient behavior of the MIMO α -MRAC does not depend on any kind of richness or persistent excitation condition. An accepted idea found in the literature says that the class of adaptive algorithm based on certainty equivalence principle cannot provide a satisfactory transient without a good estimation of the plant parameters. This is not verified by the MIMO α -MRAC, which has shown that this is, in fact, possible. Extensive simulations have confirmed the improved transient behavior of the MIMO α -MRAC.

REFERENCES

- M. A. Ortega and Yu Tang. Adaptive control of robots with improvement transient performance. *IEEE Trans. Aut. Contr.*, 47:1198–1202, 2002.
- C. Cao and N. Hovakimyan. Design and analysis of a novel \mathcal{L}_1 adaptive control architecture, part I: Control signal and asymptotic stability. *Proc. American Contr. Conf.*, pages 3397–3402, 2006a.
- C. Cao and N. Hovakimyan. Design and analysis of a novel \mathcal{L}_1 adaptive control architecture, part II: Guaranteed transient performance. *Proc. American Contr. Conf.*, pages 3403–3408, 2006b.
- C. Cao and N. Hovakimyan. Guaranteed transient performance with \mathcal{L}_1 adaptive controller for systems with unknown time-varying parameters: Part I. *Proc. American Contr. Conf.*, 2007a.
- C. Cao and N. Hovakimyan. Extension of \mathcal{L}_1 adaptive output feedback controller to systems of unknown dimension. *Proc. American Contr. Conf.*, 2007b.
- Ramon R. Costa. Improving transient behavior of model-reference adaptive control. In *Proc. American Contr. Conf.*, San Diego, 1999.
- Ramon R. Costa, Liu Hsu, Alvaro K. Imai, and P. Kokotović. Lyapunov-based adaptive control of mimo systems. volume 39, 2003.
- A. Datta and M. T. Ho. On modifying model reference adaptive control schemes for performance improvement. *IEEE Trans. Aut. Contr.*, 39, 1994.
- A. Datta and P. A. Ioannou. Performance analysis and improvement in model reference adaptive control. *IEEE Trans. Aut. Contr.*, 39, 1994.
- W. E. Dixon, M. S. Queiroz, D. M. Dawson, and T. J. Flynn. Adaptive tracking and regulation of a wheeled mobile robot with controller/update law modularity. *IEEE Trans. on Contr. Systems Technology*, 12:138–147, 2004.
- Hassan K. Khalil. *Nonlinear Systems*. Macmillan Publishing Company, 1992.
- Petar V. Kokotović, Hassan K. Khalil, and John O'Reilly. *Singular Perturbation Methods in Control: Analysis and Design*. Academic Press, 1986.
- A. S. Morse. A gain matrix decomposition and some of its applications. *Systems and Contr. Letters*, 21:1–10, 1993.
- K. Narendra and J. Balakrishnan. Improvement transient response of adaptive control systems using multiple and switching. *IEEE Trans. Aut. Contr.*, 39:1861–1866, 1994.
- R. Ortega, L. Praly, and I. Landau. Robustness of discrete-time direct adaptive controller. *IEEE Trans. Aut. Contr.*, 39(1), 1994.
- I. N. M. Papadakis and S. C. A. Thomopoulos. Improvement performance MRAC with parameters mismatch compensation. *IEEE Trans. Aut. Contr.*, 41, 1996.
- S. S. Sastry and M. Bodson. *Adaptive Control: Stability, Convergence and Robustness*. Prentice Hall, 1989.
- Gilbert Strang. *Linear Algebra and Its Applications, 3rd Edition*. Academic Press, Inc., 1988.
- J. Sun. A modified model reference adaptive control scheme for improvement transient performance. *IEEE Trans. Aut. Contr.*, 38(8), Aug. 1993.
- G. Tao. *Adaptive Control Design and Analysis*. John Wiley & Sons, 2003.
- Z. Zang and R. R. Bitmead. Transient bound for adaptive control systems. *IEEE Trans. Aut. Contr.*, 30:1179–1187, 1994.