

Control and Sensor Fault-Tolerance of Vehicle Lateral Dynamics

M. Oudghiri, *Student Member, IEEE*, M. Chadli and A. El hajjaji

Modélisation, Information et Systèmes

University of Picardie Jules Verne

Tel: +33(0)3-82-22-76-84/80

*E-mail: { mohammed.oudghiri, mohammed.chadli,
ahmed.hajjaji }@u-picardie.fr*

Abstract: In this paper, fault tolerant control (FTC) system is developed for lateral vehicle dynamics by combining static output feedback control and sliding mode observers for improving vehicle handling and stability under sensors faults. The system consists of three blocks: fault detection and isolation (FDI) block, a static output feedback controller block and a switcher block. The nonlinear two degrees of freedom vehicle motion (bicycle model) is described by a Takagi-Sugeno (T-S) fuzzy model. The strategy of the FDI method is based on a bank of observers, each one is constructed using sliding mode design techniques to estimate the system state vector. Thus the diagnostic signal-residuals are generated by the comparison of measured and estimated outputs and the faulty sensor is isolated. Simulations demonstrate that the vehicle maintains acceptable performance after either set of yaw rate sensor and lateral velocity sensor has failed.

Keywords: Fault tolerant control; vehicle dynamics; Takagi-sugeno fuzzy model; Sliding mode observers; Static output feedback; *LMF*.

1. INTRODUCTION

One of the main areas of research being undertaken in the automotive industry is that of vehicle chassis control in terms of handling performance, ride comfort and traction/braking performance (Canale and Fagiano (2007)). The principle aims of this research include improvements in vehicle safety, steerability/manoeuvrability, increase passenger comfort and reduce driver workload. many solutions have been proposed in recent years by the introduction and the development of new driver assisted systems such as anti-lock braking systems (ABS), electronic stabilization program (ESP), dynamic stability control (DSC), etc. Some of these systems have become an integral part of modern passenger vehicles. However, each physical components, sensors or actuators may fail; a fault can propagate very quickly if it is not recovered in time. To cope with increasing requirements, vehicle control systems must include FDI units and advanced fault tolerant control systems (Isermann (2001), Hsiao and Tomizuka (2004), Oudghiri et al (2007a), Chadli et al (2008)).

Our aim is to develop a sensor FTC system to avoid the degradation of vehicle performances when some sensors fault happen in input variables of the controller. The given method is based on a FDI module to detect the presence of an incipient fault and to isolate it.

The objective of developing fault tolerant measurement schemes is to provide correct information of the process to the controller.

The strategy of the fault detection and isolation (FDI) used in this paper is based on a bank of two sliding mode

observers (SMO), each utilizing different measurements to estimate the system state vector, from this the diagnostic signal-residuals are generated by the comparison of measured and estimated outputs and then the faulty sensor is isolated. Two static output feedback controllers (SOFC) (Chadli et al (2002)) have been used, each one uses one output sensor, after the detection and the isolation of the faulty sensor, a switcher block selects the right controller (which is based on the healthy sensor output) in order to maintain the stability and the handling of the vehicle.

The paper is organized as follows. Section 2 describes both the nonlinear simulation model used to test the scheme and a Takagi-Sugeno (T-S) fuzzy model used for controllers and observers design. Section 3 presents the fault tolerant controller design, based on sliding mode observers and the static output feedback controllers. Section 4 is dedicated to simulations of sensor faults and results analysis. Conclusions are given in Section 5.

2. VEHICLE DYNAMICS MODELING

Control design will be worked out on the basis of the single track vehicle model reported in figure 1, with tyre dynamic force generation description. The employed model is based on the following hypothesis:

- Flat road.
- Longitudinal motion resistances are ignored.
- No rear wheel steering angle.
- Vehicle longitudinal acceleration is low or equal to zeros.

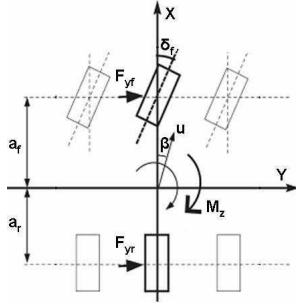

Fig. 1. Bicycle model (2dof)

Tyre lateral forces are obtained by Pacejka formulation Bakker et al (89). Thus for the considered model, dynamic equations are the following:

$$m\dot{v}(t) + mu_r(t) = 2F_{yf}(t) + 2F_{yr}(t), \quad (1a)$$

$$J\dot{r}(t) = 2a_f F_{yf}(t) - 2a_r F_{yr}(t), \quad (1b)$$

The meaning of each symbol is listed in Table 1.

u_l	longitudinal vehicle velocity (m/s)
v	lateral vehicle velocity (m/s)
β	side slip angle ($\beta = \frac{v}{u}$) (rad)
r	yaw rate (rad/s)
δ_f	front steering angle (rad)
m	total mass of the vehicle (kg)
J	yaw moment of inertia (kgm^2)
a_f/a_r	distance between the CG and the front/rear bumper (m)
F_{yf}/F_{yr}	front and rear lateral forces (N)

Table 1. nomenclature of the bicycle model

By using the method based on T-S approximation proposed in (Hajjaji et al (2006); Oudghiri et al (2007a)), the rear and front lateral forces, can be described by two fuzzy rules as follows

$$F_{yf} = \sum_{i=1}^2 h_i(|\alpha_f|(t)) C_{fi} \alpha_f(t), \quad (2a)$$

$$F_{yr} = \sum_{i=1}^2 h_i(|\alpha_f|(t)) C_{ri} \alpha_r(t), \quad (2b)$$

where C_{fi} and C_{ri} are the cornering stiffness coefficients of the front and rear wheels. They vary according to the road adhesion μ . Variables α_f and α_r represent tyre slip-angles at the front and rear of the vehicle respectively. Given that

$$\alpha_f = \frac{-v - a_f r}{u} + \delta_f \quad (3)$$

$$\alpha_r = \frac{-v + a_r r}{u} \quad (4)$$

$h_i(i = 1, 2)$ are membership functions, they depend of the front tyre slip-angle α_f which is considered available, they satisfy the following conditions

$$\begin{cases} \sum_{i=1}^2 h_i(|\alpha_f|) = 1 \\ 0 \leq h_i(|\alpha_f|) \leq 1 \quad \forall i = 1, 2 \end{cases} \quad (5)$$

Substituting (2a) and (2b) into equations (1a) and (1b), we obtain:

$$\begin{aligned} m\dot{v}(t) + mur(t) &= 2 \sum_{i=1}^2 h_i(\alpha_f(t)) C_{fi} \left(\frac{-v - a_f r}{u} + \delta_f \right) \\ &+ 2 \sum_{i=1}^2 h_i(\alpha_f(t)) C_{ri} \left(\frac{-v + a_r r}{u} \right), \end{aligned} \quad (6)$$

$$\begin{aligned} J\dot{r}(t) &= 2a_f \sum_{i=1}^2 h_i(\alpha_f(t)) C_{fi} \left(\frac{-v - a_f r}{u} + \delta_f \right) \\ &- 2a_r \sum_{i=1}^2 h_i(\alpha_f(t)) C_{ri} \left(\frac{-v + a_r r}{u} \right), \end{aligned} \quad (7)$$

from (6) and (7), we obtain

$$\begin{aligned} \dot{v}(t) &= \sum_{i=1}^2 h_i(\alpha_f(t)) \left(\left(-2 \frac{C_{fi} + C_{ri}}{mu} \right) v \right. \\ &\left. + \left(-2 \frac{C_{fi} a_f - C_{ri} a_r}{mu} - u \right) r + 2 \frac{C_{fi}}{m} \delta_f \right), \end{aligned} \quad (8)$$

$$\begin{aligned} \dot{r}(t) &= \sum_{i=1}^2 h_i(|\alpha_f|(t)) \left(\left(-2 \frac{C_{fi} a_f - C_{ri} a_r}{Ju} \right) v \right. \\ &\left. + \left(-2 \frac{C_{fi} a_f^2 + C_{ri} a_r^2}{Ju} \right) r + 2 \frac{a_f C_{fi}}{J} \delta_f \right), \end{aligned} \quad (9)$$

We assume that $\delta_f = \delta_{fd} + \delta_{fc}$, where δ_{fd} represents the steering angle supposed given by the driver and δ_{fc} represents the input signal.

In the proposed model, it is assumed that measurements of lateral velocity v and yaw rate, r are available. It is also assumed that the front road-wheel steer angle δ_{fd} is known.

From (8) and (9), in state space, the lateral motion can be expressed by:

$$\dot{x}(t) = \sum_{i=1}^2 h_i(|\alpha_f|(t)) (A_i x(t) + B_i (\delta_{fd} + \delta_{fc})) \quad (10)$$

$$y(t) = Cx(t) \quad (11)$$

with the following data:

$$A_i = \begin{pmatrix} -2 \frac{C_{fi} + C_{ri}}{mu} & -2 \frac{C_{fi} a_f - C_{ri} a_r}{mu} - u \\ -2 \frac{C_{fi} a_f - C_{ri} a_r}{Ju} & -2 \frac{C_{fi} a_f^2 + C_{ri} a_r^2}{Ju} \end{pmatrix},$$

$$B_i = \begin{pmatrix} 2 \frac{C_{fi}}{m} \\ 2 \frac{a_f C_{fi}}{J} \end{pmatrix}, \quad x(t) = \begin{pmatrix} v(t) \\ r(t) \end{pmatrix},$$

When the output variable is the measurement of the lateral velocity ($y = v$), the output matrix is $C = C_1 = [1 \ 0]$ and when the measurement output is the yaw rate ($y = r$), the output matrix is $C = C_2 = [0 \ 1]$.

To take into account variation of the road adhesion parameter and modelling errors, we assume that vehicle model is uncertain and can be written as follows:

$$\dot{x}(t) = \sum_{i=1}^2 h_i(|\alpha_f|(t)) ((A_i + \Delta A_i)x(t) + (B_i + \Delta B_i)(\delta_{fd}(t) + \delta_{fc}(t))) \quad (12)$$

where ΔA_i and ΔB_i represent parametric uncertainties, they can be formulated as follows

$$\Delta A_i = D_{A_i} H_i(t) E_{A_i}, \quad \Delta B_i = D_{B_i} H_i(t) E_{B_i} \quad (13)$$

where D_{A_i} , D_{B_i} , E_{A_i} and E_{B_i} are known real matrices of appropriate dimensions that characterize the structures of uncertainties and $H_i(t)$, $i = 1, \dots, M$ are unknown matrices such that $H_i(t)^T H_i(t) < I$. I is the identity matrix of appropriate dimension.

3. FAULT TOLERANT CONTROLLER SYSTEM DESIGN

In this section, we present an active model-based FTC-scheme for vehicle lateral dynamics control system based on a FDI block to distinguish the healthy sensor from the faulty one. As shown in Fig. 2, the FTC system consists of three blocks.

FDI block: In this block, faults in lateral velocity and yaw rate sensors will be detected and isolated. The structure of this block contains two main stages:

- *Residual generation:* its purpose is to generate a signal-residual, indicating a fault.

- *Decision Making:* residuals " R_i " are examined for the likelihood of fault and a decision rule is then applied to determine whether or not faults appear in sensors, i.e. the residual must satisfy the following conditions:

$$|R_i| \begin{cases} \approx 0 & \Rightarrow f(t) = 0 \text{ (normal)} \\ \gg 0 & \Rightarrow f(t) \neq 0 \text{ (faulty)} \end{cases} \quad (14)$$

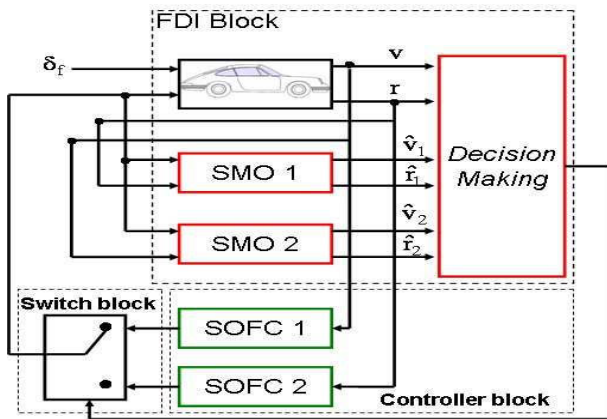

Fig. 2. Structure of the FTC system

The strategy of the fault diagnosis method presented in this paper is based in using a bank of two observers to estimate the system state vector, each one is driven by a single sensor output; from this the diagnostic signal-residuals are generated by the comparison of measured and estimated outputs. Different methods exist for the residuals generation (see for example Gertler (1998)). In this paper, we use the SMO (Oudghiri et al (2007b)).

This class of observer is very useful and was developed for many reasons, among which: (Castillo and Anzures (2005), Edwards et al (2005))

- i) The possibility of working with reduced observation error dynamics.
- ii) A finite time convergence for all the observable states.
- iii) Robustness under parameter variations is possible.

Table 2 lists the generated residuals

Variable	Residual 1	Residual 2
Lateral velocity	$R_{v,1} = v - \hat{v}_1$	$R_{v,2} = v - \hat{v}_2$
Yaw rate	$R_{r,1} = r - \hat{r}_1$	$R_{r,2} = r - \hat{r}_2$

Table 2. List of generated residuals

Here, note that the ' $\hat{\cdot}$ ' denotes estimate and the '1' or '2' subscript denotes the estimate from the first or the second observer.

From these residuals, the presence or absence of a particular fault can be deduced using the following rules

- i) Only one fault is present at any time.
- ii) If a sensor is faulty all the estimated from the observer that uses that sensor are affected.

From the above rules the following logic table (Table 3) can be constructed to uniquely identify the fault. Note that in the second column of the table the values of the elements of the residual vector are denoted by '1's and '0's, the ones denoting non-zero elements and the zeros denoting elements whose value is zero.

Fault	$[R_{v,1} \ R_{v,2} \ R_{r,1} \ R_{r,2}]$
Lateral velocity sensor	$[0 \ 1 \ 1 \ 1]$
Yaw rate sensor	$[1 \ 1 \ 1 \ 0]$

Table 3. Logic Table for Fault Isolation

Controller block: it consists of two static output feedback controllers (Chadli et al (2002)), the controller 1 uses the lateral velocity measurement and the controller 2 uses the yaw rate measurement. The design of this controller and stability conditions are given below.

Switch block: if $R_{v,2}$ is large and $R_{r,1}$ is low then switch to SOFC 2 otherwise switch to SOFC 1.

Before giving the design of each one of FDI block and controller block, let us considering the following assumptions

3.1 Assumptions

i) Sensor failures are modeled as additive signals to sensors outputs

$$y = C_i x + D_i f(t), \quad \text{with } i = 1, 2. \quad (15)$$

Where $i = 1$ when $y = v$, $i = 2$ when $y = r$. $f(t)$ represents sensor faults and D_i ($i = 1, 2$) represent distribution matrices. They are defined as follows

- For failure of lateral velocity sensor $D_1 = [d_1 \ d_2]^T = [1 \ 0]^T$.

- For failure of yaw rate sensor $D_2 = [d_1 \ d_2]^T = [0 \ 1]^T$.

ii) At any time at most one sensor fails.

iii) All pairs (A_i, C_i) are observable.

3.2 Design of FDI functional block

The structure of the FDI functional block is shown in Fig.2. It consists of two sliding mode observers. Each one is driven by only one of two available sensor signals. For state estimation, we consider an uncertain fuzzy model as follows:

Let us consider the general case of an uncertain fuzzy system with unknown inputs

$$\begin{aligned} \dot{x}(t) &= \sum_{i=1}^M h_i(z) [(A_i + \Delta A_i)x(t) \\ &\quad + (B_i + \Delta B_i)u(t)] \\ y(t) &= Cx(t) \end{aligned} \quad (16)$$

where M is the number of sub-models, $x(t) \in \mathbb{R}^p$ is the state vector, $u(t) \in \mathbb{R}^m$ is the input vector, $y(t) \in \mathbb{R}^l$ is the output vector, A_i , B_i and C are time invariant matrices of appropriate dimensions. ΔA_i , ΔB_i represent parametric uncertainties, they are defined in (13). The vector $z(t) \in \mathbb{R}^q$ is the decision variable.

The fuzzy system (16) can be rewritten as :

$$\begin{aligned} \dot{x}(t) &= \sum_{i=1}^M h_i(z) [A_i x(t) + B_i u(t) + w(t)] \\ y(t) &= Cx(t) \end{aligned} \quad (17)$$

where $w(t) = \Delta A_i x(t) + \Delta B_i u(t)$. Its is assumed to be bounded, such that $\|w(t)\| < \rho$, where ρ is a positive scalar. In the following $w(t)$ is considered as unknown input.

The proposed fuzzy observer of the uncertain fuzzy system with unknown input (17) is based on a linear combination of local Luenberger observer involving sliding terms allowing to compensate the unknown inputs ($w(t)$). It has the following form:

$$\begin{aligned} \dot{\xi}(t) &= \sum_{i=1}^M h_i(z) (A_i \xi(t) + B_i u(t) + G_i (y - C\xi) + \alpha_i) \\ \hat{y}(t) &= C\xi(t) \end{aligned} \quad (18)$$

The aim of the design is to determine gain matrices $G_i \in \mathbb{R}^{p \times q}$ and $\alpha_i \in \mathbb{R}^p$, that guarantee the asymptotic convergence of $\xi(t)$ towards $x(t)$.

Theorem 1. The state estimation of the robust state multiple observer (18) converges globally asymptotically to the state of the fuzzy system (16), if there exist a matrix $P > 0$, some matrices L_i and W_i satisfying the following constraints:

$$\begin{bmatrix} A_i^T P + P A_i - C^T W_i^T - W_i C & P \\ P & -I \end{bmatrix} < 0 \quad (19)$$

$$C^T L_i^T = P, \quad (i = 1, \dots, M) \quad (20)$$

with $G_i = P^{-1}W_i$.

And $\alpha_i(t)$ is given by the following equations:

$$\begin{cases} \text{if } r(t) \neq 0 : \alpha_i(t) = \rho \frac{L_i r}{\|L_i r\|} \\ \text{if } r(t) = 0 : \alpha_i(t) = 0 \end{cases} \quad (21)$$

with $r(t) = y(t) - \hat{y}(t)$.

Proof: see Oudghiri et al (2007b).

The structure of the two observers used in the FTC scheme (Fig.2) are given as:

- SMO 1:

$$\begin{aligned} \dot{\xi}_1(t) &= \sum_{i=1}^2 h_i(|\alpha_f|) (A_i \xi_1(t) + B_{i1}(\delta_{fd}(t) + \delta_{fc}(t)) \\ &\quad + G_i^1 (v(t) - C_1 \xi(t)) + \alpha_i^1(t)) \\ \hat{y}(t) &= \hat{v}(t) = C_1 \xi(t) \end{aligned} \quad (22)$$

- SMO 2:

$$\begin{aligned} \dot{\xi}_2(t) &= \sum_{i=1}^2 h_i(|\alpha_f|) (A_i \xi_2(t) + B_{i1}(\delta_{fd}(t) + \delta_{fc}(t)) \\ &\quad + G_i^2 (r(t) - C_2 \xi(t)) + \alpha_i^2(t)) \\ \hat{y}(t) &= \hat{r}(t) = C_2 \xi(t) \end{aligned} \quad (23)$$

where G_j^i , and α_j^i with $i, j \in \{1, 2\}$ are constant to be determined by solving (19) and (20).

3.3 Static output feedback design

Consider the nonlinear system represented by a T-S fuzzy model 16 and a nonlinear static output feedback which shares the same activation functions as the T-S model (16):

$$u(t) = \sum_{i=1}^M h_i(z) F_i y(t) \quad (24)$$

where $F_i \in \mathbb{R}^{m \times l}$ is the local output feedback controller to determine.

Taking into account the expression (24), the closed loop model becomes:

$$\dot{x}(t) = \sum_{i=1}^M \sum_{j=1}^M h_i(z) h_j(z) (\bar{A}_{ij} + \Delta \bar{A}_{ij}) x(t) \quad (25)$$

where

$$\bar{A}_{ij} = A_i + B_i F_j C, \quad \Delta \bar{A}_{ij} = \Delta A_i + \Delta B_i F_j C \quad (26)$$

Theorem 2. suppose that there exist matrices N_i , M , S_{ij} and Q and scalars ϵ_{ij} , δ_{ij} such that $\forall i < j, (i, j) \in I_M^2$:

$$Q > 0 \quad (27)$$

$$\begin{pmatrix} T_{ii} + S_{ii} & * & * \\ E_{Ai} Q & -\epsilon_{ii} I & * \\ E_{Bi} N C & 0 & -\delta_{ii} I \end{pmatrix} < 0 \quad (28)$$

$$\begin{pmatrix} T_{ij} + T_{ji} + S_{ij} + S_{ij}^T & * & * \\ \begin{pmatrix} E_{Ai} \\ E_{Aj} \end{pmatrix} Q & - \begin{pmatrix} \varepsilon_{ij} I & 0 \\ 0 & \varepsilon_{ji} I \end{pmatrix} & * \\ \begin{pmatrix} E_{Bi} N_j \\ E_{Bj} N_i \end{pmatrix} C & 0 & - \begin{pmatrix} \delta_{ij} I & 0 \\ 0 & \delta_{ji} I \end{pmatrix} \end{pmatrix} \quad (20)$$

$$\begin{pmatrix} S_{11} & S_{12} & \cdots & S_{1M} \\ S_{12}^T & S_{22} & \cdots & S_{2M} \\ \vdots & \vdots & \ddots & \vdots \\ S_{1M}^T & S_{2M}^T & \cdots & S_{MM} \end{pmatrix} > 0 \quad (30)$$

$$CQ = MC \quad (31)$$

with:

$$T_{ij} = QA_i^T + A_i Q + C^T N_j^T B_i^T + B_i N_j C + \varepsilon_{ij} D_i D_i^T + \delta_{ij} D_i D_i^T.$$

Then there exist a nonlinear output feedback $u(t) = \sum_{i=1}^M h_i(z) F_i y(t)$ that stabilizes globally asymptotically the T-S model (16) with $F_i = N_i C C^T (C Q C^T)^{-1} \forall i \in \{1, \dots, M\}$.

Proof: The proof can be obtained directly from (Chadli et al (2002)).

For the vehicle FTC system developed in this paper, the two used controllers have the following expressions:

- Controller 1:

$$\delta_{fc1}(t) = \sum_{i=1}^2 h_i(z) F_i^1 v(t) = \sum_{i=1}^2 h_i(z) F_i^1 C_1 x \quad (32)$$

where $F_i^1 = F_i$ when $C = C_1$

- Controller 2:

$$\delta_{fc2}(t) = \sum_{i=1}^2 h_i(z) F_i^2 r(t) = \sum_{i=1}^2 h_i(z) F_i^2 C_2 x \quad (33)$$

where $F_i^2 = F_i$ when $C = C_2$

with F_i^j ($i, j \in \{1, 2\}$) are controller gains to be determined.

4. SIMULATION RESULTS

In the following simulations, we set the longitudinal speed u to be 20m/s and with the following values of the other involved parameters:

$$\begin{aligned} m &= 1500Kg, & J &= 3000Kg m^2 \\ a_f &= 1.3m, & a_r &= 1.2m \\ C_{f1} &= 60712NM/rad, & C_{f2} &= 4812NM/rad \\ C_{r1} &= 60088NM/rad, & C_{f1} &= 3455NM/rad \end{aligned}$$

The simultaneous resolution of equations (27-31) using LMI tools leads to the following results :

Gains of controller 1 (with $C = C_1 = [1 \ 0]$) :

$$F_1^1 = -0.0422, \quad F_2^1 = -0.0014$$

Gains of controller 2 (with $C = C_2 = [0 \ 1]$) :

$$F_2^1 = -5.8156, \quad F_2^2 = -3.2056$$

To obtain observer gains, we resolve equations given in (19).

Gains of SMO 1 :

$$\begin{aligned} G_1^1 &= [91.0911 \ -22.8865]^T, \quad G_1^2 = [36.0722 \ -9.9945]^T \\ \alpha_1^1 &= 2.1745, \quad \alpha_1^2 = 0.1037 \end{aligned}$$

Gains of SMO 2 :

$$\begin{aligned} G_2^1 &= [163.2350 \ 488.8202]^T, \quad G_2^2 = [22.3700 \ 495.4687]^T \\ \alpha_2^1 &= 13.6562, \quad \alpha_2^2 = 0.9496 \end{aligned}$$

In all simulations we consider that the steering angle δ_{fd} is known and given by the driver as shown in figure 3.

For showing the effectiveness of the proposed method, we study three cases:

Case 1: FTC strategy is not used, only controller 1 (32) is used and the lateral velocity sensor is faulty between 2s and 4s (see Fig 4). We can notice in figure 5 that the vehicle performances are degraded when lateral velocity sensor is faulty.

Case 2: FTC strategy is not used, only controller 2 (33) is used and the yaw rate sensor is faulty between 6s and 8s (see Fig 6). We can notice in figure 7 that the vehicle performances are degraded when yaw rate sensor is faulty.

Case 3: FTC strategy is used. We consider that lateral velocity sensor is faulty between 2s and 4s and yaw rate sensor is faulty between 6s and 8s (see Fig 8). We can notice in figure 9 that the vehicle remains stable all time of simulation without lost of control of system state.

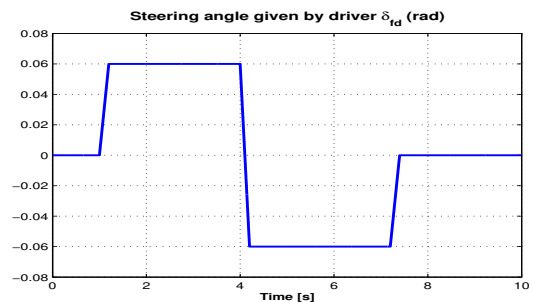

Fig. 3. Steering angle

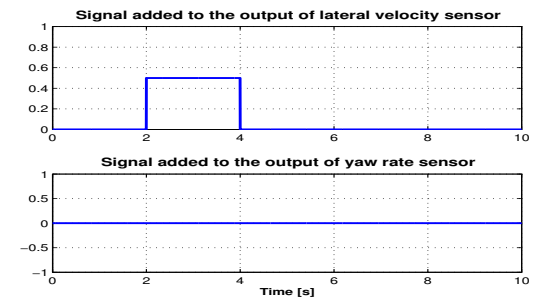

Fig. 4. Additive Sensor Failures

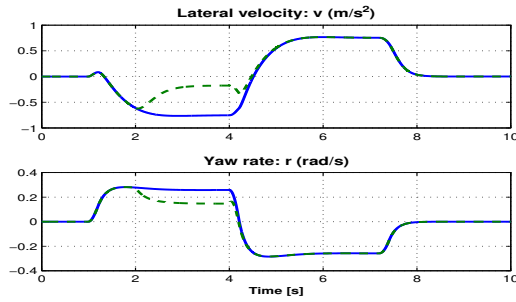

Fig. 5. **Without FTC** strategy: comparison between vehicle response when all sensors are healthy (solid line) and vehicle response when the lateral velocity sensor is faulty between 2s and 4s (dotted line)

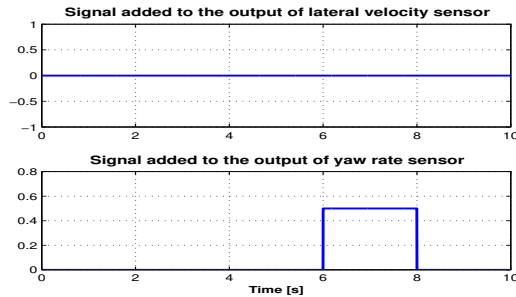

Fig. 6. Additive Sensor Failures

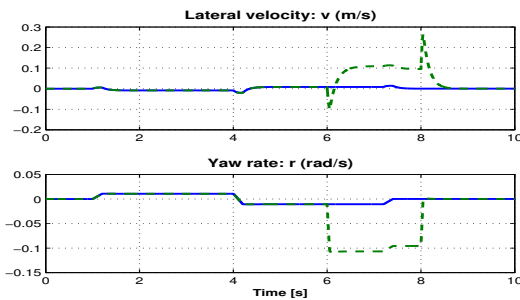

Fig. 7. **Without FTC** strategy: comparison between vehicle response when all sensors are healthy (solid line) and vehicle response when the yaw rate sensor is faulty between 6s and 8s (dotted line)

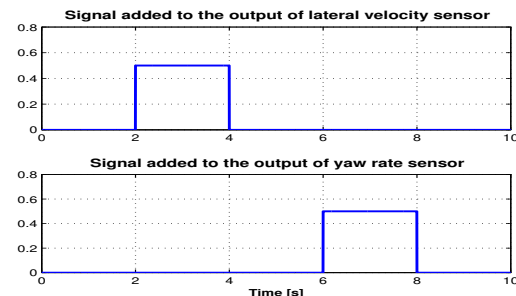

Fig. 8. Additive Sensor Failures

5. CONCLUSION

We proposed an active FTC approach to accommodate yaw rate sensor failures and lateral velocity sensor failures of the vehicle lateral control system. The strategy is based

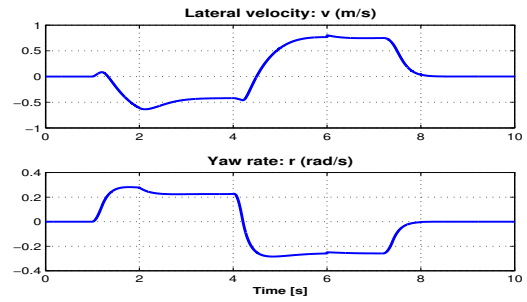

Fig. 9. Vehicle response **With FTC** strategy

on a block of two sliding mode observers for detecting and isolating failures, a block of two static output feedback controllers and switcher block for selecting the right controller. Simulations demonstrate the effectiveness of the proposed algorithm (SMO + SOFC).

REFERENCES

E. Bakker L. Linder, H. B. Pacejka. A new tyre model with an application in vehicle dynamics studies. *SAE*, vol.98, N.6, pp.101-113, 1989.

A. El Hajjaji, M. Chadli, M. Oudghiri and O. Pagès. Observer-based robust fuzzy control for lateral dynamics. *American Control Conference*, pp. 4664-4669, 2006.

M.Oudghiri, M.Chadli and A. El hajjaji. Observer-based fault tolerant control for vehicle lateral dynamics. *European Control Conference*, pp.632-637, 2007.

M.Oudghiri, M.Chadli and A. El hajjaji. Lateral Vehicle Velocity Estimation Using Fuzzy Sliding Mode Observer. *The 15th Mediterranean Conference on Control and Automation-MED*, pp. 1-6, 2007.

M. Chadli, A. Elhajjaji, M. Oudghiri. Robust Output Fuzzy Control for Vehicle Lateral Dynamic Stability Improvement. *International Journal of Modelling, Identification and Control*, vol.3, 2006, in press.

M. Canale and L. Fagiano. Comparing RWS and RAD approaches in robust vehicle yaw control. *European Control Conference*, pp.1225-1232, 2007.

A.Akhenak, M.Chadli, D.Maquin and J.Ragot. State estimation of uncertain multiple model with unknown inputs. *The 43rd IEEE Conference on Decision and Control*, pp.3563-3568, vol.4, 2004.

J.J. Gertler. Fault Detection and Diagnosis in Engineering Systems. *Marcer Dekker*, 1998.

M. Chadli, D. Maquin and J. Ragot. An LMI formulation for output feedback stabilization in multiple model approach. *Conference on Decision and Control*, vol.1, pp.311-316, 2002.

B. Castillo-Toledo and J. Anzurez-Marin. Model-based fault diagnosis using sliding mode observers to Takagi-Sugeno fuzzy model. *International Symposium on Intelligent Control*, 2005.

R.Isermann. Diagnosis Methods for Electronic Controlled Vehicles. *Vehicle System Dynamics*, 2001.

T.Hsiao and M.Tomizuka. Observer-based sensor fault detection and identification with application to vehicle lateral control. *American Control Conference*, vol.1, pp.810 - 815, 2004.

C.Edwards, R.G.Herbden and S.K.Supergeon. Sliding mode observers for vehicle mode detection. *Vehicle System Dynamics*, vol. 43, No. 11, pp. 823-843, 2005.