

## Active Queue Management Algorithm Based on Fuzzy Sliding Model Controller

Yuanwei Jing\*, Na Yu\*, Zhi Kong\*, Georgi M. Dimirovski\*\*

\* College of Information Science and Engineering, Northeastern University,  
Shenyang, Liaoning, 110004, P.R. of China

(e-mail: ywjing@mail.neu.edu.cn; cuina1116@yahoo.com.cn).

\*\* Faculty of Engineering, Dogus University of Istanbul, TR-347222 Istanbul,  
Rep. of Turkey, (e-mail: gdimirovski@dogus.edu.tr)

---

**Abstract:** The active queue management (AQM) problem of networks is discussed. An AQM scheme is presented based on improved sliding model controller. The proposed controller combines the excellent characteristics of linear sliding model controller (LSMC) and the terminal sliding model controller (TSMC). The LSMC is used to speed up the error convergence when the error is greater than one, and the TSMC is adopted to guarantee the error convergence to zero in a finite time when the error is around the zero. The chattering in the conventional sliding model control systems is avoided with the employed continuous controller. The simulation results show that the proposed scheme has strong robust against the network modeling uncertainties and disturbances, as well as leads to the convergence of the output queue to the desired value quickly and precisely than employing either LSMC or TSMC alone.

---

### 1. INTRODUCTION

If there are more data packets in networks, then the network performance will descend, that is called congestion (Nagle, 1984). It seems that it is the direct results of lacking network resource (Luo *et al.*, 2001, Ren *et al.*, 2003). But increasing the single resource purely is no sense. It needs a congestion control scheme on the networks to solve the congestion problem. The TCP congestion control mechanisms, while necessary and powerful, are not sufficient to provide good services in all circumstances, especially with the rapid growth in size and the strong requirement for QoS guarantee, because there is a limit much control can be accomplished at the end system. It is needed to implement some measures in the intermediate nodes to complement the end system congestion avoidance mechanisms.

Active queue management (AQM), as a class of packet marker/dropping mechanism in the router queue, is recently proposed to support the end-to-end congestion control in the Internet (Braden *et al.*, 1998). It has been a very active research area in the Internet community. RED (Floyd *et al.*, 1993) is originally proposed to achieve fairness among sources with different burst attributes and to control queue length. Despite of its meeting the requirements of AQM, it depends on experience and the optimal parameters are hard to obtain, as well as the design is not always scientific and reasonable for all conditions.

There are different methods based on TCP model to overcome its disadvantages. For example, Hollot *et al.* (2001) employs the control theory to set the parameters. The non-linear dynamic model for TCP flow control (Misra *et al.*, 2001) is inspired by Hollot to design the PI controller for AQM. But systems can not work well under the dynamics

circumstance, for they always base on the certainly linear model. Considering the uncertain parameters, the method to control the congestion should have strong robustness.

In this paper, we will follow the design approach based on the theoretical model. Sliding mode control (SMC) is robust to uncertainty and disturbances, as well as has good transient performance. SMC is employed to solve this problem in several references. But based on the references (Man *et al.*, 1994, 1995), we can see that the error convergence in linear sliding mode control (LSMC) systems is faster if the absolute values of errors are greater than one and then the error will asymptotically converge to zero if the time  $t$  tends to infinity. However the terminal sliding control system (TSMC) has a different convergence property. That is, if the error is greater than one, the error convergence is slower than that in the LSMC. After the error is less than one, the error can quickly converge to zero in a finite time in the TSMC systems.

Based on the above observation, we propose a new fuzzy sliding mode controller to combine the advantages of both the LSMC and TSMC to improve the error convergence. It is shown that the design of sliding mode control system is divided into two steps. An LSMC controller is designed first to speed up the error convergence. A TSMC controller is then designed to guarantee that the error converges to zero in a finite time near the system origin. In order to have a smooth switching from the LSMC controller to the TSMC controller, a fuzzy logic technique is used to connect the two sliding mode surfaces.

This paper is organized as follows. The mathematical model is depicted in Section 2. The sliding switching surface is designed in Section 3. Then the fuzzy sliding mode controller (FSMC) is designed in Section 4. In Section 5, the simulation

results show that the proposed approach is feasible. Finally, some concluding remark is drawn in Section 6.

## 2. TCP MATHEMATICS MODEL

By considering the time-delay in state, the TCP model can be written as follows (Misra *et al.*, 2001).

$$\begin{cases} \dot{W}(t) = \frac{1}{R(t)} - \frac{W(t)W(t-R(t))}{2R(t)} p(t) \\ \dot{q}(t) = \frac{N(t)}{R(t)} W(t) - C(t) \end{cases} \quad (1)$$

where  $W(t)$  is the size of congestion window,  $q(t)$  is the instantaneous queue in the buffer,  $R(t)$  is the round-trip delay. (where  $R(t) = T_p + q(t)/C(t)$ ),  $T_p$  is the transport time-delay.  $0 \leq p(t) \leq 1$  is the marker/dropping probability.  $C(t)$  is the link capacity.  $N(t)$  is the TCP connections.

The instantaneous queue and the size of the congestion window are positive, namely,  $q(t) \in [0, \bar{q}]$ ,  $W(t) \in [0, \bar{W}]$ , where  $\bar{q}(t)$ ,  $\bar{W}$  denote buffer capability and maximum size of congestion window respectively. The value of marker/dropping probability ranges from 0 to 1.

Consider the network topology structure with singularity bottle-neck. Its various structure diagram is shown in Fig. 1.

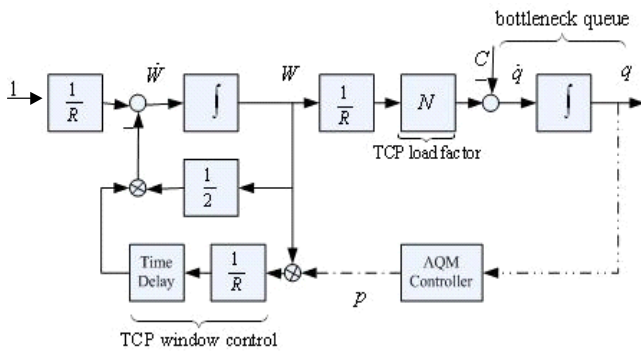

Fig. 1. The configuration chart of TCP changed congestion window

Let  $N(t) = N_0$ ,  $R(t) = R_0$  and  $C(t) = C_0$  be the normal value. System (1) is linearized at equilibrium  $(W_0, q_0, p_0)$  (Hollot *et al.*, 2001), then,

$$\begin{cases} \delta \dot{W}(t) = -\frac{2N_0}{R_0^3 C_0} \delta W(t) - \frac{R_2 C_0^2}{2N_0^2} \delta p(t) \\ \delta \dot{q}(t) = \frac{N_0}{R_0} \delta W(t) - \frac{1}{R_0} \delta q(t) \end{cases} \quad (2)$$

where  $\delta W(t) = W(t) - W_0$ ,  $\delta q(t) = q(t) - q_0$ ,  $\delta p(t) = p(t) - p_0$ .

Let  $e = \delta q = x_1$ ,  $\dot{e} = \delta \dot{q} = x_2$ ,  $u = \delta p$ . Neglecting time-delay, Equation (2) can be depicted as (Ren *et al.*, 2003)

$$\begin{cases} \dot{x}_1 = x_2 \\ \dot{x}_2 = -\frac{2N_0}{R_0^3 C_0} x_1 - \left( \frac{2N_0}{R_0^2 C_0} + \frac{1}{R_0} \right) x_2 - \frac{C_0^2}{2N_0} u(t) \end{cases} \quad (3)$$

It can be seen that the system parameters  $N(t)$ ,  $R(t)$ , and  $C(t)$  change with time. Therefore it incorporates uncertainty, and disturbances. Thus, consider the model as follows,

$$\begin{cases} \dot{x}_1 = x_2 \\ \dot{x}_2 = -a_1 x_1 - a_2 x_2 - bu + f(t, x) + \Delta b(t)u \end{cases} \quad (4)$$

where

$$\begin{aligned} a_1 &= \frac{2N(t)}{R_0(t)^3 C(t)} \\ a_2 &= \frac{1}{R_0(t)} + \frac{2N(t)}{R_0^2(t)C(t)} \\ b &= \frac{C(t)^2}{2N(t)} \end{aligned}$$

Assume that the matching conditions holds, *i.e.*,

$$f(t, x) = b\gamma_1(t, x), \quad \Delta b(t) = b\gamma_2(t).$$

and  $\gamma_1(t, x), \gamma_2(t)$  are bounded, *i.e.*  $|\gamma_1(t, x) + \gamma_2(t)| < l$ . Thus (4) can be written as

$$\dot{x}_2 = -a_1 x_1 - a_2 x_2 - b(u - \gamma_1(t, x) - \gamma_2(t)) \quad (5)$$

Let  $u' = u - \gamma_1(t, x) - \gamma_2(t)$ . We obtain

$$\dot{x}_2 = -a_1 x_1 - a_2 x_2 - bu' \quad (6)$$

## 3. FUZZY SLIDING MODE COONTROL

Let  $e = x_1$ , where  $e$  is the error, then  $\dot{e} = \dot{x}_1 = x_2$ , and  $\ddot{e} = -(a_1 x_1 + a_2 x_2 + bu')$ .

If the absolute value of  $e$  is bigger than  $e_b$ , the linear sliding mode control is used to speed up the error convergence. If the absolute value of  $e$  is smaller than  $e_a$ , a terminal sliding mode is employed to obtain a finite error convergence. A fuzzy switching function  $\alpha(e)$  is introduced to smoothly change the sliding mode surfaces when the error  $e$  is between  $e_a$  and  $e_b$ , or between  $-e_a$ , and  $-e_b$ .

For the linear sliding mode control part, the hype-plane is defined as

$$s = \dot{e} + he \quad (7)$$

For the terminal sliding mode control part, the hype-plane is defined as

$$s = \dot{e} + he^p \quad (8)$$

where  $p = p_1 / p_2$  and  $p_1, p_2$  are positive odd integers, also  $p_1 < p_2$  is a positive constant.

Then the new fuzzy hype-plane variable can be written as:

$$\begin{aligned} s &= \alpha s_T + (1-\alpha)s_L \\ &= \alpha(\dot{e} + he^p) + (1-\alpha)(\dot{e} + he) \\ &= \dot{e} + h\alpha e^p + h(1-\alpha)e \end{aligned} \quad (9)$$

The trapezoid membership function is chosen as in Fig. 2.

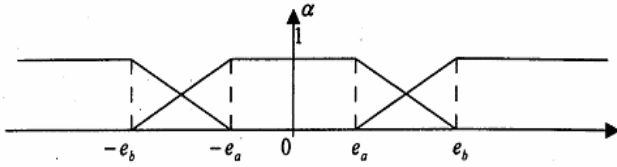

Fig. 2. Membership function

Then we get the membership function  $\alpha(e)$  as

$$\alpha = \begin{cases} 1 & |e| < e_a \\ \frac{e_b - e}{e_b - e_a} & e_a < e < e_b \\ \frac{e_b - e}{e_b - e_a} & -e_b < e < -e_a \\ 0 & |e| > e_b \end{cases} \quad (10)$$

The fuzzy sliding mode variable  $s$  in (9) works according to the following rules:

(a) If  $|e|$  is smaller than  $e_a$ , then  $\alpha(e)=1$  and the fuzzy sliding mode variable in (8) is a pure terminal sliding mode variable  $s = s_T$ . The error dynamics will converge to zero in a finite time.

(b) If  $|e|$  is bigger than  $e_b$ , then the fuzzy sliding mode variable is a pure linear sliding mode variable  $s = s_L$ .

(c) If  $e_a < e < e_b$ , then  $s = s_3 = \frac{e_b - e}{e_b - e_a} s_T + \frac{e - e_a}{e_b - e_a} s_L$ .

(d) If  $-e_b < e < -e_a$ , then  $s = s_4 = \frac{e_b + e}{e_b - e_a} s_T - \frac{e + e_a}{e_b - e_a} s_L$ .

#### 4. CONTROL DESIGN

The design of the controller and the stability analysis using the proposed fuzzy sliding mode in (6) are stated as follows:

$$u' = \begin{cases} \text{sign}(s_T)\Delta_1 & -e_a < e < e_a \\ \text{sign}(s_L)\Delta_2 & e < -e_b \text{ or } e > e_b \\ \text{sign}(s_3)\Delta_3 & e_a < e < e_b \\ \text{sign}(s_4)\Delta_4 & -e_b < e < -e_a \end{cases} \quad (11)$$

where

$$\Delta_1 > b^{-1} |-(a_1 x_1 + a_2 x_2) + hpe^{p-1} \dot{e}| \quad (12)$$

$$\Delta_2 > b^{-1} |-(a_1 x_1) - (a_2 - h)x_2| \quad (13)$$

$$\Delta_3 > \frac{b^{-1}}{|e_b - e_a|} \left| \frac{h\dot{e}(e - e^p) + (e_b - e_a)(-a_1 x_1 - a_2 x_2) + h\dot{e}(pe^{p-1}(e_b - e) + (e - e_a))}{h\dot{e}(pe^{p-1}(e_b - e) + (e - e_a))} \right| \quad (14)$$

$$\Delta_4 > \frac{b^{-1}}{|e_b - e_a|} \left| \frac{h\dot{e}(e^p - e) + (e_b - e_a)(-a_1 x_1 - a_2 x_2) + h\dot{e}(pe^{p-1}(e_b + e) - (e + e_a))}{h\dot{e}(pe^{p-1}(e_b + e) - (e + e_a))} \right| \quad (15)$$

**Theorem 1** The system is stable and the error will converge to zero in finite time, by using the rules above.

*Proof:* Define the Lyapunov function as follows.

$$V = \frac{1}{2} s^2$$

If  $|e| < e_a$ , then

$$s = s_T = \dot{e} + he^p$$

$$\begin{aligned} \dot{V} &= s_T \dot{s}_T = -s_T bu' + s_T [-(a_1 x_1 + a_2 x_2) + hpe^{p-1} \dot{e}] \\ &\leq -|s_T| b\Delta_1 + |s_T| |-(a_1 x_1 + a_2 x_2) + hpe^{p-1} \dot{e}| < 0 \end{aligned}$$

If  $|e| > e_b$ , then

$$s = s_L = \dot{e} + he$$

$$\begin{aligned} \dot{V} &= s_L \dot{s}_L = -s_L bu' + s_L [-(a_1 x_1) - (a_2 - h)x_2] \\ &\leq -|s_L| b\Delta_2 + |s_L| |-(a_1 x_1) - (a_2 - h)x_2| < 0 \end{aligned}$$

If  $e_a < e < e_b$ , then

$$s = s_3 = \frac{e_b - e}{e_b - e_a} s_T + \frac{e - e_a}{e_b - e_a} s_L$$

$$\begin{aligned} \dot{V} &= s_3 \dot{s}_3 \\ &= -s_3 bu' + \frac{s_3}{e_b - e_a} [h\dot{e}(e - e^p) + (e_b - e_a)(-a_1 x_1 - a_2 x_2) \\ &\quad + h\dot{e}(pe^{p-1}(e_b - e) + (e - e_a))] \end{aligned}$$

$$\leq -|s_3| b\Delta_3 + \frac{|s_3|}{|e_b - e_a|} \left| \frac{h\dot{e}(e - e^p) + (e_b - e_a)(-a_1 x_1 - a_2 x_2) + h\dot{e}(pe^{p-1}(e_b - e) + (e - e_a))}{h\dot{e}(pe^{p-1}(e_b - e) + (e - e_a))} \right| < 0$$

If  $-e_b < e < -e_a$ , then

$$s = s_4 = \frac{e_b + e}{e_b - e_a} s_T - \frac{e + e_a}{e_b - e_a} s_L$$

$$\begin{aligned} \dot{V} &= s_4 \dot{s}_4 \\ &= -s_4 b u' + \frac{s_4}{e_b - e_a} [h\dot{e}(e^p - e) + (e_b - e_a)(-a_1 x_1 - a_2 x_2) \\ &\quad + h\dot{e}(pe^{p-1}(e_b + e) - (e + e_a))] \\ &\leq -|s_4| \left[ b\Delta_4 + \frac{|s_4|}{|e_b - e_a|} \left| \begin{aligned} &h\dot{e}(e^p - e) + (e_b - e_a) \\ &(-a_1 x_1 - a_2 x_2) + \\ &h\dot{e}(pe^{p-1}(e_b + e) - (e + e_a)) \end{aligned} \right| \right] < 0 \end{aligned}$$

According to  $e$  belonging to different conditions, (12)~(15) will ensure  $\dot{V} < 0$ . Therefore, according to the Lyapunov stability theorem, the system is stable and the error will asymptotically converge to zero.

Thus we choose  $\Delta_i (i = 1, 2, 3, 4)$  in (8) as follows.

If  $|e| < e_a$ , then

$$\Delta_1 > b^{-1} |-(a_1 x_1 + a_2 x_2) + hpe^{p-1}\dot{e}|$$

If  $|e| > e_b$ , then

$$\Delta_2 > b^{-1} |-(a_1 x_1) - (a_2 - h)x_2|$$

If  $e_a < e < e_b$ , then

$$\Delta_3 = b^{-1} \frac{1}{|e_b - e_a|} \left| \frac{h\dot{e}(e - e^p) + (e_b - e_a)(-a_1 x_1 - a_2 x_2) + h\dot{e}(pe^{p-1}(e_b - e) + (e - e_a))}{h\dot{e}(pe^{p-1}(e_b - e) + (e - e_a))} \right| + 0.8$$

If  $-e_b < e < -e_a$ , then

$$\Delta_4 = b^{-1} \frac{1}{|e_b - e_a|} \left| \frac{h\dot{e}(e^p - e) + (e_b - e_a)(-a_1 x_1 - a_2 x_2) + h\dot{e}(pe^{p-1}(e_b + e) - (e + e_a))}{h\dot{e}(pe^{p-1}(e_b + e) - (e + e_a))} \right| + 0.8$$

### 5. SIMULATION

In this section, we will prove the efficiency and advantages over the linear sliding mode control and terminal sliding mode control by simulations.

The network topology structure considered is as in Fig. 3.

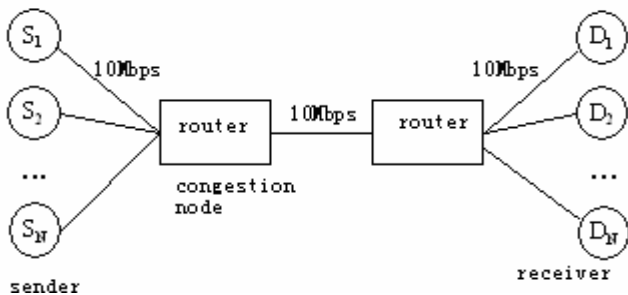

Fig. 3. Simulation network topology

Let  $e_a = 1$ ,  $e_b = 10$ . Choose the parameters  $p_1 = 3, p_2 = 5, h = 2$ ;  $R = 0.533s, N = 50, C = 300\text{packet/s}$  as chosen in the reference (Quet *et al.*, 2004).

Neglected the time-delay, simulations are given according to the parameters chosen above, we get the parameters

$$A = \begin{bmatrix} 0 & 1 \\ -2.2014 & -3.0495 \end{bmatrix}, B = \begin{bmatrix} 0 \\ -900 \end{bmatrix}$$

In order to show the advantages of the fuzzy sliding mode control over the LSMC and the TSMC, the simulations are given for LSMC and TSMC, respectively, with the same network parameters.

The simulation results are shown in Fig. 4 and Fig. 5.

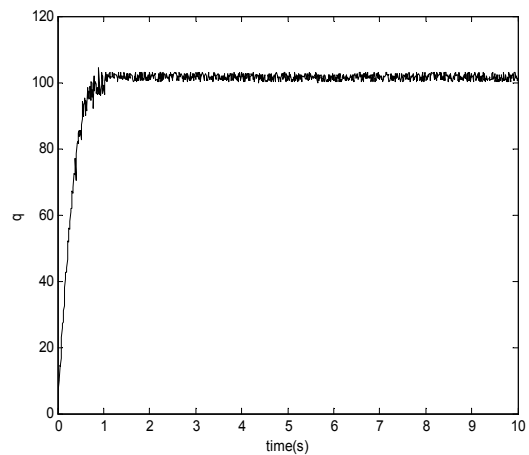

Fig. 4. The queue length using LSMC

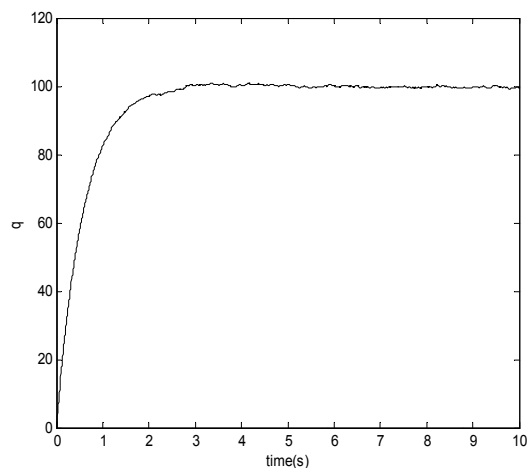

Fig. 5. The queue length using TSMC

From Fig. 4 and Fig. 5, we can see that the two controllers both can ensure the systems stability, and can almost drive the queue track to the anticipate value.

Fig. 4 shows that the queue chatters are around the anticipate value, and cannot track the anticipate value 100 in finite time.

Fig. 5 shows that the queue can track the anticipate value 100, but it seems more time needed.

In order to explain conveniently, we put the two simulation results together, as in Fig. 6.

It is shown (where real line figures the LSMC, and dotted line figures TSMC) that, under the control of LSMC, the queue can arrive at anticipate value 100 in about 1 second, but fluctuates near it. But under the control of TSMC, the queue arrives at anticipate value 100 in about 2 seconds, and almost keep this value all the time.

So LSMC cannot show the objective characters if system states approach the anticipate value, *i.e.*, it cannot drive the queue to track the anticipate value with no error; but if it is away from the anticipate value, the queue can approach it quickly.

TSMC shows the contrary characters, although the queue can track anticipate value with no error, it needs more time for arriving.

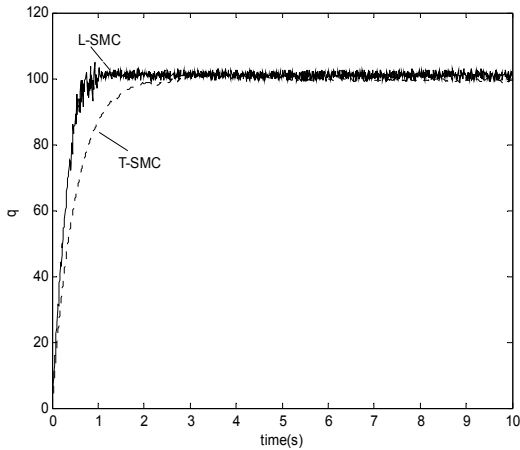

Fig. 6. The comparison of TSMC and LSMC

In order to compare with the TSMC control, the simulation for FSMC is also given with the same network parameters.

The simulation results are shown in Fig.7 (where real line figures the FSMC, and broken line figures TSMC).

If the absolute value of  $e$  is bigger than 10, it employs the LSMC method. If the error  $e$  is between 1 and 10, or between  $-1$  and  $-10$ , it employs the FSMC method. If the absolute value of  $e$  is smaller than 1, it employs the TSMC method. And it converges to zero completely in about 2 seconds, while the TSMC method needs more than 4 seconds.

Also, it can be seen that the FSMC method employed has more robust characteristics and less chattering than employing the TSMC method.

So, it proves that the FSMC method has more advantages over the TSMC method in tracking the anticipate queue. At the same time, it has more accurate tracking ability than the LSMC.

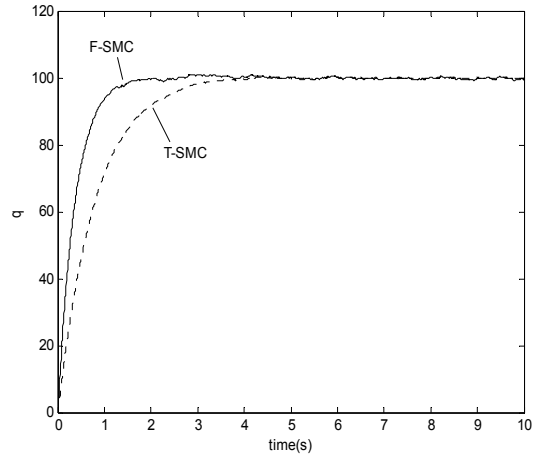

Fig. 7. Comparison between FSMC and TSMC

Fig.8 shows its robustness to the uncertainty.  $N(t)$  changes from 50 to 100, and it can converge to zero quickly, despite of a little oscillations. That is, the queue can track the anticipate queue 100 quickly.

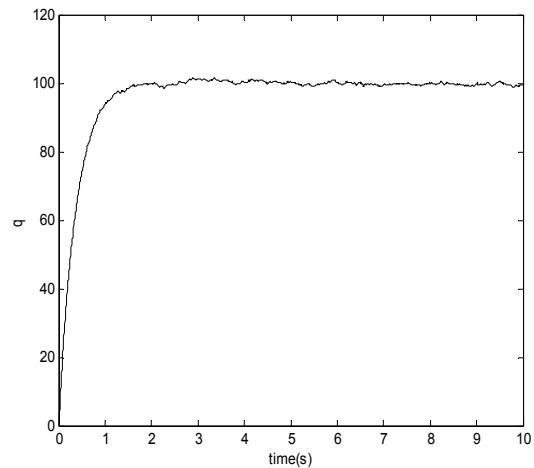

Fig. 8. FSMC with varying parameters

It can be seen that the FSMC method always has the faster error convergence though the values of parameters are time varying.

## 6. CONCLUSIONS

TCP/IP network is a dynamic system, and its parameters are time varying. And there exists extern disturbance to systems. The traditional AQM controllers usually depend on the accurate mathematical model. But sliding mode control (SMC) is not sensitive to the various parameters and disturbance. So SMC is employed in designing the AQM controllers.

This paper discussed the problem of designing the AQM controller. Based on the advantages of SMC, we combine the excellent characteristics of the LSMC and the TSMC to design the AQM controller.

As the theoretical analysis and the simulation results, it can be concluded that the proposed AQM based on fuzzy sliding mode control possesses the advantages of both the linear sliding mode control and the terminal sliding mode control. Convergence time is shortened, despite the presence of the uncertainties and disturbances. As well, for employing the fuzzy logic technique, it smoothes the switching, therefore, reduces the chattering.

#### REFERENCES

- Braden, B. *et al.* (1998). Recommendations on queue management and congestion avoidance in the Internet. *RFC 2309* April.
- Floyd, S. and V. Jacobson (1993). Random early detection gateways for congestion avoidance. *IEEE/ACM Transactions on Networking*, August, **1**, 397~413.
- Hollot, C.V., V. Misra and D. Towsley *et al.* (2001). A control theoretic analysis of RED. <http://www.net.cs.umass.edu/~misra/>.
- Luo, W.M., C. Lin and B.P. Yan (2001). A Survey of Congestion Control in TCP/IP Internet. *Chinese Journal of Computers*. **24**, 1~8
- Man, Z.H. and M. Palaniswami (1994). Robust tracking control for rigid robotic manipulators. *IEEE Transactions on Automatic Control*, **39**, 154~159.
- Man, Z.H. and M. Palaniswami (1995). A decentralized three-segment nonlinear sliding mode control for rigid robotic manipulators. *Int. J. of Adaptive Control and Signal Processing*, **9**, 443~457.
- Misra, V., W.B. Gong and D. Towsley (2001). Fluid-based analysis of a network of AQM routers supporting TCP flows with an application to RED. <http://www.net.cs.umass.edu/~misra/>
- Nagle, J. (1984). Congestion control in IP/TCP internetworks. *ACM SIGCOMM Computer Communication Review*. **14**, 11~17.
- Quet, P.F. and H. Özbay (2004). On the Design of AQM Supporting TCP Flows Using Robust Control Theory. *IEEE Transactions Automatic control*. **4**, 1031~1036.
- Ren, F.Y., C. Lin and W.D. Liu (2003). Congestion Control in IP Networks. *Chinese Journal of Computers*. **26**, 1025~1034.