

## A New Identification Method for Mechatronic Systems in closed-loop from only Control Data

Gautier M.\*,\*\*, Janot A.\*\*, Vandanjon P.O.\*\*\*

\*Université de Nantes

\*\*IRCCyN, 1, rue de la Noë - BP 92 101 - 44321 Nantes Cedex 03, France(Tel: +33 2 40 37 69 60; e-mail: maxime.gautier@irccyn.ec-nantes.fr).

\*\*\* Laboratoire Central des Ponts et Chaussées, Route de Bouaye BP 4129, 44341Bouguenais Cedex, France (e-mail: pierre.olivier.vandanjon@lcp.c.fr)

---

**Abstract:** The identification of the dynamic parameters of robot is based on the use of the inverse dynamic model which is linear with respect to the parameters. This model is sampled while the robot is tracking trajectories which excite the system dynamics in order to get an over determined linear system. The linear least squares solution of this system calculates the estimated parameters. The efficiency of this method has been proved through the experimental identification of a lot of prototypes and industrial robots. However, this method needs joint torque and position measurements and the estimation of the joint velocities and accelerations through the pass band filtering of the joint position at high sample rate. The new method needs only torque data at a low sample rate. It is based on a closed loop simulation which integrates the direct dynamic model. The optimal parameters minimize the 2 norm of the error between the actual torque and the simulated torque assuming the same control law and the same tracking trajectory. This non linear least squares problem is dramatically simplified using the inverse model to calculate the derivatives of the cost function.

---

### 1. INTRODUCTION

The usual identification method based on the inverse dynamic model (IDM) and LS technique has been successfully applied to identify inertial and friction parameters of a lot prototypes and industrial robots (Gautier *et al.*, 1995), (Gautier, 1997) and (Khalil *et al.*, 2007) among others. Recently, it was also used to identify the inertial parameters of slave and master arms developed by the CEA (Janot *et al.*, 2007 a), (Bidard *et al.*, 2005), inertial parameters of a compactor (Lemaire *et al.*, 2006) and the parameters of a car (Venture *et al.*, 2006). The obtained results were interesting and consistent. At any case, a derivative pass band data filtering is required to calculate the joint velocities and accelerations.

Another method is to minimize a quadratic error between an actual output and a simulated output of the system, assuming both the actual and simulated systems have the same input. It is known as an output error (OE) identification method or as the *model's method* (Richalet and Fiani, 1995). This method was used to identify electrical parameters of a synchronous machine (Khatounian *et al.*, 2006) and it was compared to the LS and inverse model method. The results are very close. The optimal values of the parameters are calculated using non linear programming algorithms to solve the nonlinear least squares problem. Usually, the output is a state model output such as the joint position for mechanical systems. Difficulties arise due to bad initial conditions which leads to multiple and local solutions.

These methods require both the joint position and the joint torque measurements.

The new identification method is based on a closed loop simulation using the direct dynamic model (DDM) while the optimal parameters minimize the 2 norms of the error between the actual torque and the simulated torque assuming the same control law and the same tracking trajectory. This non linear least squares problem dramatically simplifies using the inverse dynamic model (IDM) to calculate the gradient vector and the Hessian matrix of the cost function.

The paper is organized as follows: section 2 recalls the Inverse Dynamic Model and LS usual method in robotics; section 3 presents the output error identification method; section 4 presents the new identification method; section 5 gives an experimental validation performed on a 2 DOF planar robot; finally, section 5 concludes the paper.

### 2. INVERSE DYNAMIC IDENTIFICATION MODEL METHOD

The inverse dynamic model (IDM) of a rigid robot composed of  $n$  moving links calculates the motor torque vector  $\tau$  (the control input) as a function of the generalized coordinates (the state vector and its derivative). It can be written as the following relation which explicitly depends on the joint acceleration:

$$\tau = \mathbf{M}(\mathbf{q})\ddot{\mathbf{q}} + \mathbf{N}(\mathbf{q}, \dot{\mathbf{q}}) \quad (1)$$

Where  $\mathbf{q}$ ,  $\dot{\mathbf{q}}$  and  $\ddot{\mathbf{q}}$  are respectively the (nx1) vectors of generalized joint positions, velocities and accelerations,  $\mathbf{M}(\mathbf{q})$  is the (nxn) robot inertia matrix and  $\mathbf{N}(\mathbf{q}, \dot{\mathbf{q}})$  is the (nx1) vector of centrifugal, Coriolis, gravitational and friction torques.

The choice of the modified Denavit and Hartenberg frames attached to each link allows to obtain a dynamic model linear in relation to a set of standard dynamic parameters  $\chi_s$  (Gautier, 1997) and (Khalil and Kleinfinger, 1986) :

$$\boldsymbol{\tau} = \mathbf{ID}_s(\mathbf{q}, \dot{\mathbf{q}}, \ddot{\mathbf{q}})\chi_s \quad (2)$$

Where  $\mathbf{ID}_s(\mathbf{q}, \dot{\mathbf{q}}, \ddot{\mathbf{q}})$  is the regressor and  $\chi_s$  is the vector of the standard parameters which are the coefficients  $XX_j$ ,  $XY_j$ ,  $XZ_j$ ,  $YY_j$ ,  $YZ_j$ ,  $ZZ_j$  of the inertia tensor of link j denoted  ${}^j\mathbf{J}_j$ , the mass of the link j called  $m_j$ , the first moments vector of link j around the origin of frame j denoted  ${}^j\mathbf{M}_j = [MX_j \ MY_j \ MZ_j]^T$ , the friction coefficients  $f_{vj}$ ,  $f_{cj}$  and the actuator inertia called  $I_{aj}$  and the offset of current measurement denoted offset.

The base parameters are the minimum number of mechanical parameters from which the dynamic model can be calculated. They are obtained from the standard inertial parameters. The minimal inverse dynamic model can be written as:

$$\boldsymbol{\tau} = \mathbf{ID}(\mathbf{q}, \dot{\mathbf{q}}, \ddot{\mathbf{q}})\boldsymbol{\chi} \quad (3)$$

Where  $\mathbf{ID}(\mathbf{q}, \dot{\mathbf{q}}, \ddot{\mathbf{q}})$  is the minimal regressor and  $\boldsymbol{\chi}$  is the vector of the base parameters. The inverse dynamic model (3) is sampled while the robot is tracking a trajectory to get an over-determined linear system such that (Gautier, 1997):

$$\mathbf{Y}(\boldsymbol{\tau}) = \mathbf{W}(\mathbf{q}, \dot{\mathbf{q}}, \ddot{\mathbf{q}})\boldsymbol{\chi} + \boldsymbol{\rho} \quad (4)$$

With:

- $\mathbf{Y}(\boldsymbol{\tau})$  is the measurements vector,
- $\mathbf{W}$  is the observation matrix,
- $\boldsymbol{\rho}$  is the vector of errors.

The L.S. solution  $\hat{\boldsymbol{\chi}}$  minimizes the 2-norm of the vector of errors  $\boldsymbol{\rho}$ .  $\mathbf{W}$  is a  $r \times b$  full rank and well conditioned matrix where  $r = N_e \times n$ ,  $N_e$  being the number of samples, obtained by tracking "exciting" trajectories and by considering the base parameters. The LS solution  $\hat{\boldsymbol{\chi}}$  is given by:

$$\hat{\boldsymbol{\chi}} = \left( (\mathbf{W}^T \mathbf{W})^{-1} \mathbf{W}^T \right) \mathbf{Y} = \mathbf{W}^+ \mathbf{Y} \quad (5)$$

It is calculated using the QR factorization of  $\mathbf{W}$ . Standard deviations  $\sigma_{\hat{\chi}_i}$  are estimated using classical and simple results from statistics. The matrix  $\mathbf{W}$  is supposed deterministic, and  $\boldsymbol{\rho}$ , a zero-mean additive independent noise, with a standard deviation such as:

$$\mathbf{C}_{\rho\rho} = \mathbf{E}(\boldsymbol{\rho}^T \boldsymbol{\rho}) = \sigma_\rho^2 \mathbf{I}_r \quad (6)$$

where  $\mathbf{E}$  is the expectation operator and  $\mathbf{I}_r$ , the  $r \times r$  identity matrix. An unbiased estimation of  $\sigma_\rho$  is:

$$\hat{\sigma}_\rho^2 = \|\mathbf{Y} - \mathbf{W} \hat{\boldsymbol{\chi}}\| / (r-b) \quad (7)$$

The covariance matrix of the standard deviation is calculated as follows:

$$\mathbf{C}_{\hat{\boldsymbol{\chi}}\hat{\boldsymbol{\chi}}} = \mathbf{E}[(\boldsymbol{\chi} - \hat{\boldsymbol{\chi}})(\boldsymbol{\chi} - \hat{\boldsymbol{\chi}})^T] = \sigma_\rho^2 (\mathbf{W}^T \mathbf{W})^{-1} \quad (8)$$

$\sigma_{\hat{\chi}_i}^2 = C_{\hat{\boldsymbol{\chi}}\hat{\boldsymbol{\chi}}_{ii}}$  is the  $i^{\text{th}}$  diagonal coefficient of  $\mathbf{C}_{\hat{\boldsymbol{\chi}}\hat{\boldsymbol{\chi}}}$ . The relative standard deviation  $\% \sigma_{\hat{\chi}_i}$  is given by:

$$\% \sigma_{\hat{\chi}_i} = 100 \sigma_{\hat{\chi}_i} / \hat{\chi}_i \quad (9)$$

However, experimental data are corrupted by noise and error modeling and  $\mathbf{W}$  is not deterministic. This problem can be solved by filtering the measurement matrix  $\mathbf{Y}$  and the columns of the observation matrix  $\mathbf{W}$  as described in (Gautier, 1997) and (Khalil *et al.*, 2007). This identification method is illustrated in Fig. 1:

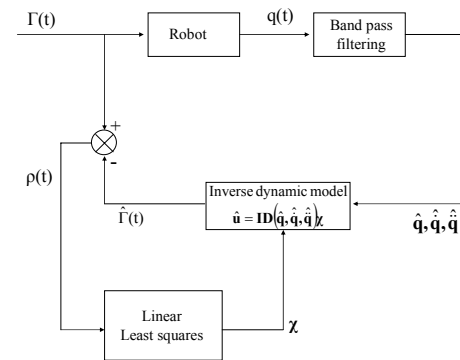

Fig. 1: Identification method based on the inverse dynamic model

The use of LS is particularly interesting because no integration of the differential equations is required and there is no need of initial conditions. However, the calculation of the velocities and accelerations are required using well tuned band pass filtering of the joint position (Gautier, 1997) and (Pham *et al.*, 2001).

### 3. OUTPUT ERROR IDENTIFICATION METHOD

The OE identification methods consist in minimizing a quadratic error between an actual output and a simulated output of the system, assuming both the actual and simulated systems have the same input. Usually, this output is a state model output such as the joint position for mechanical systems (Khatounian *et al.*, 2006), (Walter and Pronzato, 1997) and (Richalet and Fiani, 1995) (Fig. 2). Hence, an OE method needs the integration of the state equation which is the direct dynamic model for robots.

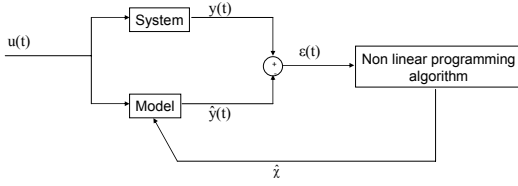

Fig. 2: OE identification method using non linear programming algorithms  
Generally, the non linear programming algorithm minimizes the quadratic error between the actual output and the estimated output.

Compared to IDIM and LS, these techniques are quite time consuming because the state equation of the system and its sensitivity functions (the derivative of the output w.r.t the parameters) must be integrated on a long time and many times at each step of the recursive non linear optimization method. More over, difficulties arise with multiple and local solutions depending on the initial conditions.

#### 4. DIDIM: DIRECT and INVERSE DYNAMIC IDENTIFICATION MODELS METHOD

The new identification method is based on a closed loop simulation using the DDM. The optimal parameters minimize the 2 norm of the error between the actual and the simulated torque. It overcomes the non linear LS problems by using the IDIM to calculate the gradient and the hessian of the cost function of this non linear LS problem. Details on the DIDIM method are given in (Janot, 2007c).

The optimal solution  $\hat{\chi}$  is given by:

$$\hat{\chi} = \underset{\chi}{\text{Argmin}} \|\mathbf{y} - \mathbf{y}_s(\chi)\|^2 \quad (10)$$

It minimizes the cost function:

$$J(\chi) = \|\mathbf{y} - \mathbf{y}_s(\chi)\|^2 \quad (11)$$

This is a non linear least squares problem which can be solved with the Newton's method because of its quadratic convergence. Hence, it comes:

$$\hat{\chi}_{k+1} = \hat{\chi}_k - \left( \nabla^2 J(\hat{\chi}_k) \right)^{-1} \nabla J(\hat{\chi}_k) \quad (12)$$

We introduce the estimation error:

$$\boldsymbol{\varepsilon} = \mathbf{y} - \mathbf{y}_s(\chi) .$$

The gradient vector is given by  $\nabla J(\chi) = 2(\nabla \boldsymbol{\varepsilon})^T \boldsymbol{\varepsilon}$  and with the Gauss Newton approximation, the hessian matrix is given by  $\nabla^2 J(\chi) \approx 2(\nabla \boldsymbol{\varepsilon})^T \nabla \boldsymbol{\varepsilon}$ .

As the IDIM is linear to the parameters,  $\mathbf{y}$  is chosen as a sampling of  $\boldsymbol{\tau}$  instead of a sampling of  $\mathbf{q}$  in the OE method, i.e.  $\mathbf{y} = \mathbf{Y}$ . The output of the OE method is the control input of the simulated system. The cost function is:

$$J(\chi) = \|\mathbf{Y} - \mathbf{W}_s(\mathbf{q}_s(\chi), \dot{\mathbf{q}}_s(\chi), \ddot{\mathbf{q}}_s(\chi))\chi\|^2 \quad (13)$$

$\mathbf{W}_s(\mathbf{q}_s(\chi), \dot{\mathbf{q}}_s(\chi), \ddot{\mathbf{q}}_s(\chi))$  is the observation matrix built with the simulated positions, velocities and accelerations respectively denoted  $\mathbf{q}_s, \dot{\mathbf{q}}_s, \ddot{\mathbf{q}}_s$ , that is:

$$\mathbf{W}_s(\mathbf{q}_s(\chi), \dot{\mathbf{q}}_s(\chi), \ddot{\mathbf{q}}_s(\chi)) = \begin{bmatrix} \mathbf{ID}_{S1}(\mathbf{q}_{S1}, \dot{\mathbf{q}}_{S1}, \ddot{\mathbf{q}}_{S1}) \\ \vdots \\ \mathbf{ID}_{Sr}(\mathbf{q}_{Sr}, \dot{\mathbf{q}}_{Sr}, \ddot{\mathbf{q}}_{Sr}) \end{bmatrix} \quad (14)$$

These states are calculated by integrating the DDM:

$$\ddot{\mathbf{q}}_s = \mathbf{M}^{-1}(\mathbf{q}_s, \chi) (\boldsymbol{\tau}_s - \mathbf{N}(\mathbf{q}_s, \dot{\mathbf{q}}_s, \chi)) \quad (15)$$

$\mathbf{M}(\mathbf{q}_s, \chi)$  is the inertia matrix and  $\mathbf{N}(\mathbf{q}_s, \dot{\mathbf{q}}_s, \chi)$  is the vector regrouping the Coriolis, the gravity and the friction effects. Finally, the criterion to be minimized is:

$$J(\chi) = \|\mathbf{Y} - \mathbf{W}_s \chi\|^2 = \boldsymbol{\varepsilon}^T \boldsymbol{\varepsilon} \quad (16)$$

Now, the derivatives of  $J(\chi)$  are calculated. The gradient of  $\boldsymbol{\varepsilon}$  equals the sensitivity functions,  $\nabla \boldsymbol{\varepsilon} = \nabla \mathbf{Y}_s$ . It is approximated by the following relation:

$$\nabla \boldsymbol{\varepsilon} = -\mathbf{W}_s - \left( \frac{\partial \mathbf{W}_s(\mathbf{q}_s(\chi), \dot{\mathbf{q}}_s(\chi), \ddot{\mathbf{q}}_s(\chi))}{\partial \chi} \right) \chi \approx -\mathbf{W}_s \quad (17)$$

This is possible because of the closed loop simulation which assumes that  $\mathbf{q}_s, \dot{\mathbf{q}}_s, \ddot{\mathbf{q}}_s$  closely track the reference trajectory for a wide range of  $\chi$  values.

This is the point of the DIDIM method where the sensitivity functions are the columns of  $\mathbf{W}_s$  which are algebraic expressions easily calculated by the IDM.

Equation (17) is the approximation used in the Gauss Newton method. This approximation simplifies considerably the calculation of the sensitivity functions. Then, at each step, the Gauss Newton method reduces to a linear LS problem, that is:

$$\hat{\chi}_{k+1} = \underset{\chi}{\text{Argmin}} \|\mathbf{Y} - \mathbf{W}_s(\mathbf{q}_s(\hat{\chi}_k), \dot{\mathbf{q}}_s(\hat{\chi}_k), \ddot{\mathbf{q}}_s(\hat{\chi}_k))\chi\|^2 \quad (18)$$

$$\hat{\chi}_{k+1} = \left( \mathbf{W}_s^T(\hat{\chi}_k) \mathbf{W}_s(\hat{\chi}_k) \right)^{-1} \mathbf{W}_s^T(\hat{\chi}_k) \mathbf{Y} \quad (19)$$

$$\mathbf{W}_s(\mathbf{q}_s(\hat{\chi}_k), \dot{\mathbf{q}}_s(\hat{\chi}_k), \ddot{\mathbf{q}}_s(\hat{\chi}_k)) = \mathbf{W}_s(\hat{\chi}_k) \quad (20)$$

This approach is particularly interesting because of the following reasons:

- Only one signal is needed, the actuator torque,
- The data filtering is the integration of the direct dynamic model which is a low pass integral filter without any tuning,
- The expressions of the sensitivity functions are simple,
- It combines the inverse and the direct dynamic models and validates both models for computed torque control and for simulation purposes.

The identification process can be resumed by the following algorithm illustrated Fig. 3:

- The algorithm is initialized with values which can be very different from the real ones,
- At each step of the recursive algorithm,  $q_s, \dot{q}_s, \ddot{q}_s$ , are calculated by simulation of the closed loop robot tracking exciting trajectories using the Direct Dynamic model.  $W_s$  is obtained as a sampling of the Inverse Dynamic model  $ID_s(q_s, \dot{q}_s, \ddot{q}_s)$ ,
- $\hat{\chi}_{k+1}$  is the LS solution of (18),
- The algorithm stops when the relative error decreases under a chosen small number tol:  $\frac{\|\epsilon_{k+1}\| - \|\epsilon_k\|}{\|\epsilon_k\|} \leq \text{tol}$

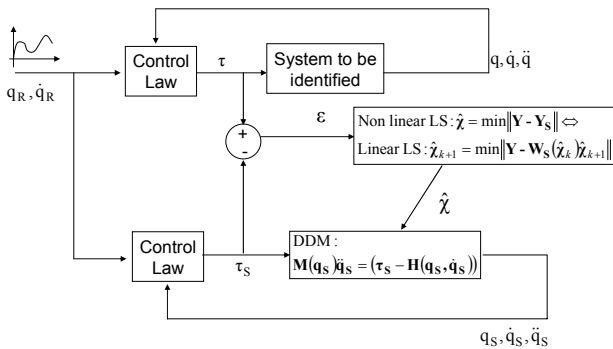

Fig. 3: Scheme of the algorithm of the new identification method

In the following, this identification process is applied to a 2 DOF robot.

## 5. EXPERIMENTAL VALIDATION

### 5.1 Presentation of the SCARA robot

The identification method described is carried out on a 2 joints planar direct drive prototype robot without gravity effect. The description of the geometry of the robot uses the modified Denavit and Hartenberg notation (Khalil and Kleinfinger, 1986) and the notations are illustrated in Fig. 4. The robot is direct driven by 2 DC permanent magnet motors supplied by PWM choppers.

The dynamic model depends on 8 minimal dynamic parameters, considering 4 friction parameters:

$$\chi = [ZZ_{1R} \ fv_1 \ fc_1 \ ZZ_2 \ MX_2 \ MY_2 \ fv_2 \ fc_2]^T.$$

Where:  $ZZ_{1R} = ZZ_1 + Ia_1$ . More details about the modelling and ID identification can be found in [2].

The closed loop is a simple PD control law. The sample control rate is 200Hz. Torque data are obtained from the current reference  $v_{ir}$  assuming a large bandwidth (1 KHz) of the current closed loop such as:

$$\tau_j = g_{tj} v_{ij} \quad (21)$$

$g_{tj}$  being the transmission gain of the joint  $j$ .

The simulation of the robot is carried out with the same trajectory generator and the same control law as the actual robot.

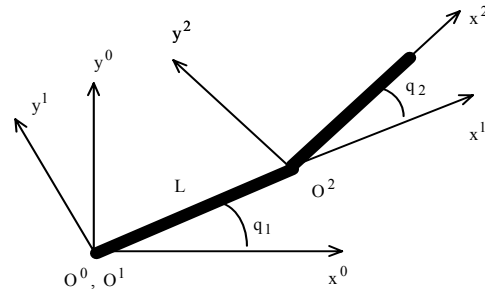

Fig. 4: SCARA robot : frames and joint variables

### 5.2 Experimental identification results

The new identification method is tested varying the initial conditions, the filtering of torque data, the acquisition sampling rate...

At first, the algorithm is initialized with the values identified through the IDIM LS estimator which will be called the optimal solution in the following. In this case, the torque data are low pass filtered with a cut off frequency of 4Hz.

The results are summarized in Table 1. Only 2 steps are enough to obtain a solution close to the optimal one. Hence, the DIDIM method does not improve the IDIM LS solution in the case of good filtering data. This result agrees with those exposed in (Vandanjon *et al.*, 2007), (Janot *et al.*, 2007 b) and (Marcassus *et al.*, 2007).

Direct validations have been performed (Fig. 5 and Fig. 6). The predicted torque is very close to the actual one (relative error less than 5%).

TABLE 1: IDIM AND DIDIM COMPARISON WITH 4HZ CUT OFF FREQUENCY.

Parameter	IDIM LS	% $\sigma_{X_j}$ (%)	DIDIM	% $\sigma_{X_j}$ (%)
$ZZ_{1R}$	3,43 Kgm <sup>2</sup>	0,50	3,45 Kgm <sup>2</sup>	0,52
$fv_1$	0,03 Nms/rad	52,0	0,04 Nms/rad	40,0
$fs_1$	0,82 Nm	6,0	0,82 Nm	3,0
$ZZ_2$	0,063 Kgm <sup>2</sup>	0,51	0,061 Kgm <sup>2</sup>	0,49
$MX_2$	0,241 Kgm	0,56	0,248 Kgm	0,52
$MY_2$	0,014 Kgm	5,0	0,014 Kgm	3,5
$fv_2$	0,013Nms/rad	23,0	0,014Nms/rad	30,0
$fs_2$	0,137 Nm	2,30	0,133 Nm	3,0
	$\ \rho\  = 16 \text{ Nm}$		$\ \epsilon\  = 15 \text{ Nm}$	

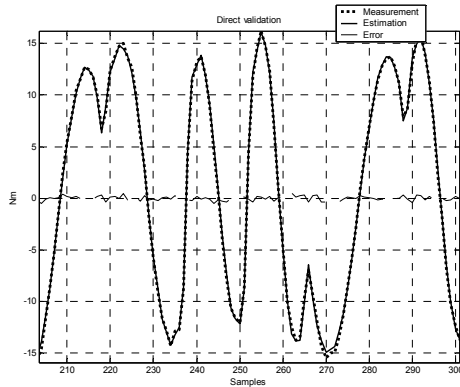

Fig. 5: DIDIM direct validation, axis 1.

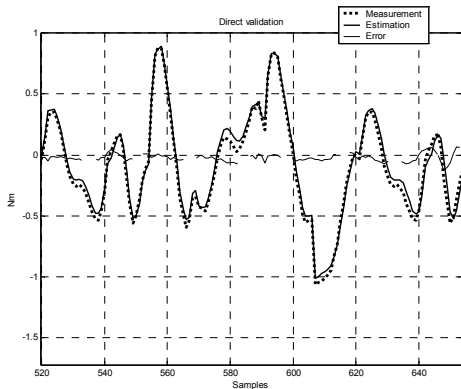

Fig. 6: DIDIM direct validation, axis 2.

Now, the robustness of the algorithm with respect to a bad initialization is analyzed. The initial values of the inertia parameters are divided by 100 from the optimal values while the other values are fixed at 0.

The results are summarized in Table 2. Only 5 steps are enough to reach the optimal solution of Table 1. This justifies the approximation made in (17). This result is very important because the algorithm is quite robust with respect to a bad initialization. So, it comes that the algorithm converges quickly and it is not very time consuming.

The initial values of the inertia components  $ZZ_{1R}$  and  $ZZ_2$  can be small but must be large enough to keep the inertia matrix  $M(q)$  regular for the DDM calculation (15). Their initial values can be divided by 1000 from the optimal values and the initial values of the gravity and friction parameters can be chosen at 0, keeping the algorithm to converge in 5 steps.

TABLE 2: DIDIM WITH BAD INITIAL CONDITIONS.

Parameter	Initial values	DIDIM	$\% \sigma_{x_j}$ (%)
$ZZ_{1R}$	$3,4 \cdot 10^{-2} \text{ Kg m}^2$	$3,45 \text{ Kg m}^2$	0,2
$fv_1$	0 Nms/rad	0,02 Nms/rad	15
$fs_1$	0 Nm	0,85 Nm	1,0
$ZZ_2$	$6 \cdot 10^{-4} \text{ Kg m}^2$	$0,061 \text{ Kg m}^2$	0,1
$MX_2$	0 Kg m	0,248 Kg m	0,1
$MY_2$	0 Kg m	0,017 Kg m	2,0
$fv_2$	0 Nms/rad	0,01 Nms/rad	10
$fs_2$	0 Nm	0,132 Nm	0,3

Direct validations have been performed and they are very similar to those illustrated in Fig. 5 and Fig. 6. The estimated torque follows the noisy measured ones closely.

As a final test, the algorithm is badly initialized and the actual torque and the simulated data are under sampled at 10Hz. The results are summed up in Table 3. Once again, the identified values are very close to those given in Table 1. It is also possible to observe the simulated states and the torque data at a frequency which is lower than the frequency of the control law. That reduces the computation time of the optimal solution because of the reducing of the size of the vector  $Y$  and the size of the matrix  $W_s$ . Finally, only 4 steps are enough to reach the optimal solution. The limit frequency to observe the torque data and the simulated data is close to 4Hz.

TABLE 3: DIDIM: BAD INITIAL CONDITIONS AND UNDER SAMPLING AT 10HZ.

Parameter	Initial values	DIDIM	$\% \sigma_{x_j}$ (%)
$ZZ_{1R}$	$3,4 \cdot 10^{-2} \text{ Kg m}^2$	$3,46 \text{ Kg m}^2$	0,52
$fv_1$	$1 \cdot 10^{-4} \text{ Nms/rad}$	0,04 Nms/rad	30
$fs_1$	$8 \cdot 10^{-3} \text{ Nm}$	0,81 Nm	3,0
$ZZ_2$	$6 \cdot 10^{-4} \text{ Kg m}^2$	$0,062 \text{ Kg m}^2$	0,49
$MX_2$	$0,241 \cdot 10^{-2} \text{ Kg m}$	0,249 Kg m	0,52
$MY_2$	$1 \cdot 10^{-2} \text{ Kg m}$	0,016 Kg m	4,0
$fv_2$	$1 \cdot 10^{-2} \text{ Nms/rad}$	0,01 Nms/rad	25
$fs_2$	$1 \cdot 10^{-3} \text{ Nm}$	0,13 Nm	3,0

Direct validations have been performed. The results are illustrated in Fig. 7 and Fig. 8. The estimated torque follows the noisy measured ones closely.

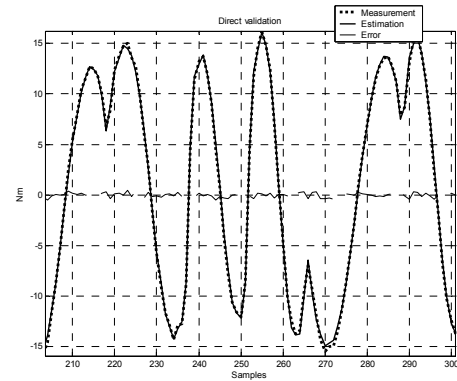

Fig. 7: DIDIM direct validation, under sampled data at 10 Hz, axis 1.

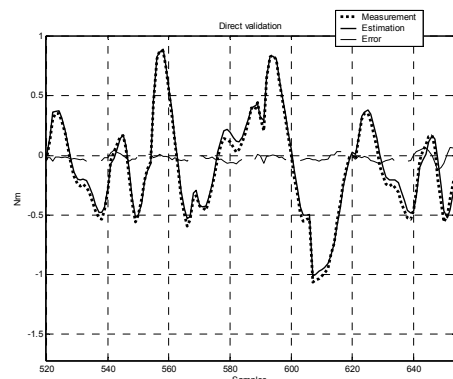

Fig. 8: DIDIM direct validation, under sampled data at 10 Hz, axis 2.

## 6. CONCLUSION

This paper has presented a new method for the identification of the dynamic and friction parameters of robots. It bypasses the need to measure or estimate joint position, velocity and acceleration by using both Direct and Inverse Dynamic Identification Models (DIDIM). It needs only torque data at a low sample rate. The optimal parameters minimize the 2 norm of the error between the actual torque and the closed loop simulated torque assuming the same control law and the same tracking trajectory. This non linear least squares problem is simplified to an iterative linear LS solution using the inverse model to calculate the derivatives of the cost function.

This method has been validated on the experimental identification of 2 DOF robot. It has been proved that it is not sensitive to bad initial conditions and to data under sampling. This is very important because in that case the ID method fails because the pass band filter cut off frequency which estimates the derivatives of the position is too small. This is often the case for industrial robots where the sample rate of the measurements is lower than the control sample rate.

This method is also particularly interesting because it validates in the same identification procedure both the inverse dynamic model which is used for computed torque control and the direct dynamic model which is used for simulation. This technique combines the advantages of the inverse dynamic and LS identification method and of the output error identification method.

However the actual control law must be known. Indeed, it is not possible to take the control torque as the input of an open loop simulation because of the instable behavior of the robot which is mainly a double integrator system. The open loop simulation is very sensitive to state initial conditions errors.

So DIDIM is complementary of the IDIM method, depending on the knowledge of the control law and on the actual measurements.

Future work concerns the validation of this technique on a 6 DOF industrial robot.

## REFERENCES

- Bidard C., Libersa C., Arhur D., Measson Y., Friconneau J.-P., Palmer J.-D. (2005), "Dynamic identification of the hydraulic MAESTRO manipulator – Relevance for monitoring", In: *Proc. of the 23rd Symposium of Fusion Technology - SOFT 23*, vol.75-79, November 2005, pp. 559–564.
- Gautier M. (1997), "Dynamic identification of robots with power model", In: *Proc. IEEE Int. Conf. on Robotics and Automation*, Albuquerque, 1997, p. 1922-1927.
- Gautier M., Khalil W. and Restrepo P. P. (1995), "Identification of the dynamic parameters of a closed loop robot", In: *Proc. IEEE on Int. Conf. on Robotics and Automation*, Nagoya, may 1995, p. 3045-3050.
- Janot A., Anastassova M., Vandanjon P.O. and Gautier M. (2007 b), "Identification process dedicated to haptic devices", In: *Proc. IEEE on Int. Conf. on Intelligent Robots and Systems*, San Diego, October 2007.
- Janot A., Bidard C., Gosselin F., Gautier M., Keller D. and Perrot Y. (2007 a), "Modeling of a three DOF haptic interface", In: *Proc. IEEE Int. Conf. on Robotics and Automation*, Roma, April 2007, pp. 4949-4955.
- Janot A. (2007 c), "Contribution à la modélisation et à l'identification des interfaces haptiques", *Thèse de doctorat de l'Université de Nantes*, December 2007.
- Khalil W. and Kleinfinger J.F. (1986), "A new geometric notation for open and closed loop robots", In: *IEEE Int. Conf. On Robotics and Automation*, San Francisco USA, April 1986, pp. 1147-1180.
- Khalil W., Gautier M. and Lemoine P. (2007), "Identification of the payload inertial parameters of industrial manipulators", In: *IEEE Int. Conf. On Robotics and Automation*, Roma Italia, April 2007, pp. 4943-4948.
- Khatounian F., Moreau S., Monmasson E., Janot A. and Louveau F. (2006), "Parameters Estimation of the Actuator Used in Haptic Interfaces: Comparison of two Identification Methods", In: *ISIE 2006*, Montreal, Canada, August-September 2006.
- Lemaire Ch.E., Vandanjon P.O., Gautier M. and Lemaire Ch. (2006), "Dynamic Identification of a Vibratory Asphalt Compactor for Contact Efforts Estimation", In: *14th IFAC Symposium on System Identification, SYSID 2006*, Newcastle Australia, March 2006, pp. 973-978.
- Marcassus N., Janot A., Vandanjon P.O. and Gautier M. (2007), "Minimal resolution for an accurate parametric identification - Application to an industrial robot arm", In: *Proc. IEEE on Int. Conf. on Intelligent Robots and Systems*, San Diego, October 2007.
- Pham M.T., Gautier M. and Poignet P. (2001), "Identification of joint stiffness with band pass filtering", In: *Proc. IEEE on Int. Conf. on Robotics and Automation*, Seoul, may 2001, p. 2867-2872
- Richalet J. and Fiani P., "The global approach in identification protocol optimization", In: *Proc. IEEE on 4<sup>th</sup> Control Applications*, 28-29 September 1995, pp. 423-431.
- Vandanjon P.O., Janot A., Gautier M. and Khatounian F., "Comparison of two identification of two identification techniques: theory and application", *ICINCO 2007, 4th International Conference on Informatics in Control, Automation and Robotics; SS on Fractional Order Systems*, Angers, Mai 2007, pp. 341-347.
- Venture G., Ripert P.-J., Khalil W., Gautier M., Bodson P. (2006), "Modelling and identification of passenger car dynamics using robotics formalism", *IEEE Transactions on Intelligent Transportation Systems*, vol. 7(3), Sept. 2006, pp 349-359.
- Walter E. and Pronzato L. (1997), "Identification of parametric models from experimental data", *Springer*, 1997.