

Implementation of Fuzzy-logic State controller in FPGA for Step-down Converter

Mitja Truntič* Miro Milanovič* Žarko Čučej*

* University of Maribor, Faculty of Electrical Engineering and Computer Science Smetanova 17, 2000 Maribor, Slovenia (Tel: +386 2 220 7339; e-mails: mitja.truntic@uni-mb.si, milanovic@uni-mb.si, zarko.cucej@uni-mb.si).

Abstract: This paper describes the implementation of fuzzy control algorithm (state controller with adjustable gains by fuzzy sets) in DC-DC Buck converter. All tasks are implemented by FPGA. Fuzzy sets are tuned by genetic algorithm of-line by using Fuzzy-logic and genetic toolbox in MATLAB. Fuzzyfication and defuzzyfication algorithms are implemented in real time in Field Programmable Gate Array (FPGA). Whole control algorithm is solved in 150 ns. The switching frequency of buck-converter PWM units is 200 kHz. This work is experimentally verified.

1. INTRODUCTION

DC-DC switching converters are due to the high efficiency an important part in power supply systems. Due to its switching mode operation DC-DC converters are nonlinear systems and have been predominately controlled by analogue integrated circuit technology with linear system design techniques Middlebrook, and Čuk. [1977]. These controllers are easy to design and implement, but their working performances depend on the working point, which makes it difficult to select the proper control parameters that will ensure stability of the system in any operating conditions.

With the rapid development of digital circuits, the digital control systems will gradually replace the currently used analogue controllers in high frequency switching converters. Among many digital control methods, fuzzy logic control (FLC) is one of the most active and promising control methods, which does neither require a precise mathematical modelling of the system nor complex computations although it has the capability to compute very fast and with high precision. Fuzzy control systems are based on expert knowledge where the human linguistic concepts are converted in to automatic control strategy. Control design of a FLC is simple as it is only based on linguistic rules it makes easy application of non-linear control laws to confront with the nonlinearities of dc-dc converters So et al. [1996], Ross [2004]. For more complex control tasks, obtaining the fuzzy knowledge base from an expert is often based on a tedious and unreliable trial and error approach and this can be partially solved with genetic algorithm parameter tuning.

This paper provides a framework for evolutionary tuning and optimization of fuzzy control systems for dc-dc converter. The strategy of tuning can also be adapted to other converter topologies. Fuzzy logic control system performance is improved with the membership functions tuning to the desired control behavior. Tuning is done by

genetic algorithm where the parameters of fuzzy system membership functions represent a population of competing chromosomes which evolve by means of selection, mutation and recombination. Criteria or fitness evaluation of an individual is done according to the fuzzy controller response in comparison to predescribed dynamics response while controlling the converter on load or voltage changes.

The main goal of research here is a feasibility study to validate a design for a low-cost, stand-alone Application-Specific Integrated Circuit (ASIC), which will contain some digital and analog elements. The ASIC chip organization is shown in Fig. 1. The work, described in this paper deals with implementation of some nonlinear control approach by using the power of FPGA. Reconfigurable P and PI controllers are studied and solved in Milanovic et al. [2007]. The State controller with fuzzy-logic adjusted gains was used in order to cover all aspects of load change. The experimental results are summarized in the last section of this paper. Whole system is verified by measurement on the functional lab experimental set.

2. EXPERIMENTAL SET DESCRIPTION

DC-DC switching power converters are essential parts of power supply systems in most electronic equipment due to their high-efficiency. Control algorithms based on the state space averaging approach have been developed in order to cover all aspects of load change Middlebrook, and Čuk. [1977] and Čuk, and Middlebrook [1981].

The advanced power management technique relies on the integration of power control and conversion functions with digital systems. Non-linear control functions can be easily implemented digitally, and contrarily these functions are sometimes very difficult to solve by an analog approach. Digital controllers have inherently lower sensitivity to process parameter variation and, consequently, it is possible to implement control schemes that are impractical for analog consideration. From the standpoint of digital system de-

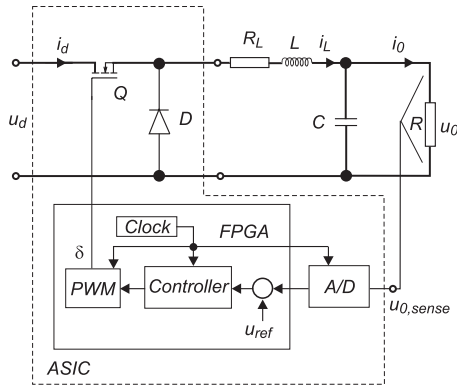

Fig. 1. Block diagrams: The whole system of the controlled Buck converter; the ASIC and FPGA chip organization

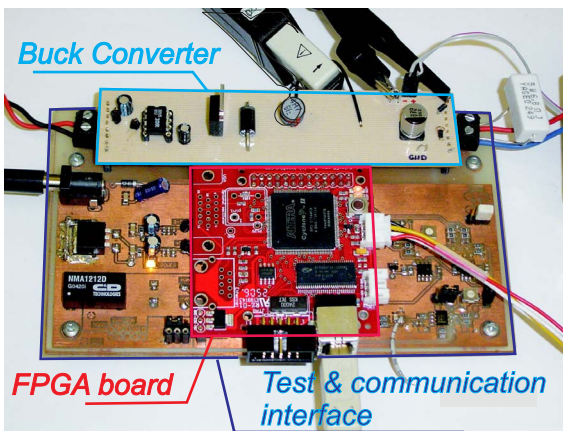

Fig. 2. Experimental set

sign, the main advantages of the digital approach are that well-established and automated design tools can be applied to shorten the design procedure So et al. [1996], Milanovic and Gleich. [2005]. Starting with VHDL-based design, synthesis, simulation and verification tools are available for the standard cell of FPGA implementation. The design can then be easily moved to a different process, integrated with other digital systems, or modified to meet a new set of requirements.

3. THE STATE CONTROLLED BUCK CONVERTER

A buck converter model is obtained using linear differential equations:

$$\begin{bmatrix} \frac{di_L}{dt} \\ \frac{du_0}{dt} \end{bmatrix} = \begin{bmatrix} -\frac{R_L}{L} & -\frac{1}{L} \\ \frac{1}{C} & -\frac{1}{RC} \end{bmatrix} \begin{bmatrix} i_L \\ u_0 \end{bmatrix} + \begin{bmatrix} \frac{1}{L} \\ 0 \end{bmatrix} u_d \delta \quad (1)$$

where i_L is the inductor current, u_0 is the output voltage, u_d is input voltage, δ is a duty cycle, L is the circuit inductance, R_L is the resistance of inductor, C is the output capacitance and R is the load resistance. In order to get the dynamic model the small signal perturbation must be introduced: $u_d = U_d + \tilde{u}_d$, $u_C = U_C + \tilde{u}_C$, $i_C = I_C + \tilde{i}_C$, $\delta = \Delta + \tilde{\delta}$, where capital letters describe the converter operating point and represent the average values of the variables and tilde $\tilde{\cdot}$ represents the perturbed variable in

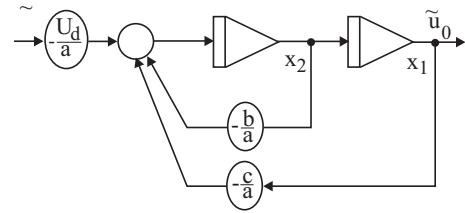

Fig. 3. Canonical form of converter model.

the operating point vicinity. The corresponding transfer function of the continuous system is given by:

$$H_1(s) = \frac{\tilde{u}_0(s)}{\tilde{\delta}(s)} \Big|_{\tilde{u}_d=0} = \frac{U_d}{as^2 + bs + c} \quad (2)$$

where $a = LC$, $b = L/R + R_L C$, and $c = 1 + R_L/R$, where $R = 6.8 \Omega$, $L = 56 \mu\text{H}$, $C = 220 \mu\text{F}$, $R_L = 0.35 \Omega$ and $U_d = 12 \text{ V}$ have been chosen. In order to control the state variables the output voltage u_0 and its derivative du_0/dt were chosen. For this purposes from (2) the controllable canonical form is obtained (Fig 3):

$$\begin{bmatrix} \frac{d\tilde{x}_1}{dt} \\ \frac{d\tilde{x}_2}{dt} \end{bmatrix} = \begin{bmatrix} 0 & 1 \\ -\frac{c}{a} & -\frac{b}{a} \end{bmatrix} \begin{bmatrix} \tilde{x}_1 \\ \tilde{x}_2 \end{bmatrix} + \begin{bmatrix} 0 \\ \frac{U_d}{a} \end{bmatrix} \tilde{\delta} \quad (3)$$

$$\begin{bmatrix} \tilde{y}_1 \\ \tilde{y}_2 \end{bmatrix} = \begin{bmatrix} \tilde{u}_0 \\ \frac{d\tilde{u}_0}{dt} \end{bmatrix} = [1 \ 0] \begin{bmatrix} \tilde{x}_1 \\ \tilde{x}_2 \end{bmatrix}$$

where $x_1 = u_0$ and $x_2 = du_0/dt$. The above system can be written in a matrix form:

$$\frac{d\tilde{\mathbf{x}}(t)}{dt} = \mathbf{A}\tilde{\mathbf{x}}(t) + \mathbf{B}\tilde{u}(t) \quad (4)$$

$$\tilde{\mathbf{y}}(t) = \mathbf{C}\tilde{\mathbf{x}}(t)$$

In order to control the converter digitally the continuous system (4) is discretized by using a sample time $T_s = 5.33 \mu\text{s}$ and zero order hold element. The discretized system is:

$$\tilde{\mathbf{x}}(k+1) = \mathbf{\Phi}\tilde{\mathbf{x}}(k) + \mathbf{\Gamma}\tilde{u}(k) \quad (5)$$

$$\tilde{\mathbf{y}}(k) = \mathbf{C}\tilde{\mathbf{x}}(k)$$

According to chosen element values the (5) the discrete matrix $\mathbf{\Phi}$ and $\mathbf{\Gamma}$ were evaluated :

$$\begin{bmatrix} \tilde{x}_1(k+1) \\ \tilde{x}_2(k+1) \end{bmatrix} = \begin{bmatrix} 0.9988 & 5.202 \cdot 10^{-6} \\ -444 & 0.9628 \end{bmatrix} \begin{bmatrix} \tilde{x}_1(k) \\ \tilde{x}_2(k) \end{bmatrix} + \begin{bmatrix} 0.01351 \\ 5067 \end{bmatrix} \tilde{\delta}(k) \quad (6)$$

$$\begin{bmatrix} \tilde{y}_1(k) \\ \tilde{y}_2(k) \end{bmatrix} = \begin{bmatrix} 1 \\ 0 \end{bmatrix} \begin{bmatrix} \tilde{x}_1(k) \\ \tilde{x}_2(k) \end{bmatrix} \quad (7)$$

The control scheme is shown in Fig. 4. The state controller was determined using a standard approach. The poles of the system were chosen in such a way, that damping factor $D = 1$ and frequency $\omega_0 = 8000$ of the characteristic polynomial $s^2 + 2d\omega_0 + \omega_0^2$, in the continuous space. The parameters were transformed into discrete space and poles of closed loop discrete transfer function were evaluated as

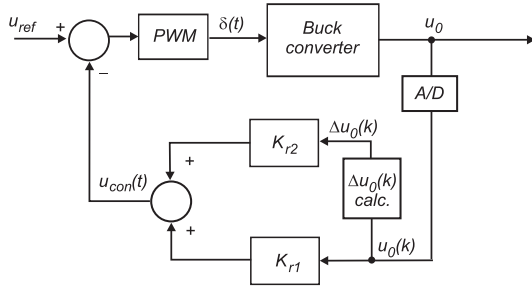

Fig. 4. The state controller scheme.

$z_1 = z_2 = e^{d\omega_0 T_s} = 0.9585$. According to this the discrete state controller gains have values:

$$\mathbf{K}_R = [K_{r1} \ K_{r2}] = [-8.76 \cdot 10^{-2} \ -7.10 \cdot 10^{-6}]. \quad (8)$$

As it is well known the state controller produce in such system the static error. The solution of this problem is described in Milanovic and Gleich. [2005], but the state space controller is also unable to reduce an over/undershoot in output voltage when the load resistance change. Changing of load (R) produces changeable system dynamics (coefficients b and c in (2)). To reduce the over/undershoot a structure of the fuzzy adjusted gains (K_{r1} and K_{r2}) of state space controller is proposed.

4. THE FUZZY STATE CONTROLLED BUCK CONVERTER

In the structure of the state space controller a nonlinear gains are used instead of a constant value of K_{r1} and K_{r2} . Fig. 5 shows so organized controller. Two fuzzy systems were designed; first fuzzy system for a voltage change (derivative) (K_{r2}) and second for a voltage (K_{r1}). Seven membership functions were used for each input/output to achieve fine decision mode. The position of membership functions can be defined by expert experience work, by using different method as are Takagi-Sugeno approach (Takagi and Sugeno. [1985]) or self-tuning by using the genetics algorithms. Membership functions are shown in Fig. 6.

Table 1. K_{r2} fuzzy rules

K_{r2}
if KR2(k)=NB then KR2y=NB
if KR2(k)=NM then KR2y=NM
if KR2(k)=NS then KR2y=NS
if KR2(k)=ZE then KR2y=ZE
if KR2(k)=PS then KR2y=PS
if KR2(k)=PM then KR2y=PM
if KR2(k)=PB then KR2y=PB

Table 2. K_{r1} fuzzy rules

K_{r1}
if KR1(k)=NB then KR1y=NB
if KR1(k)=NM then KR1y=NM
if KR1(k)=NS then KR1y=NS
if KR1(k)=ZE then KR1y=ZE
if KR1(k)=PS then KR1y=PS
if KR1(k)=PM then KR1y=PM
if KR1(k)=PB then KR1y=PB

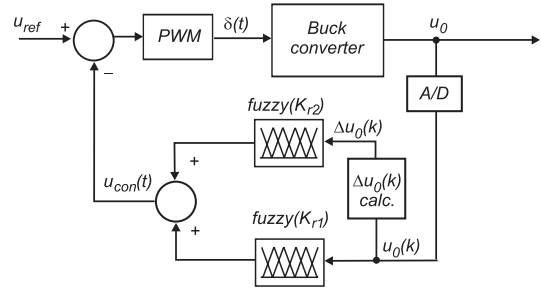

Fig. 5. Structure of fuzzy state space controller.

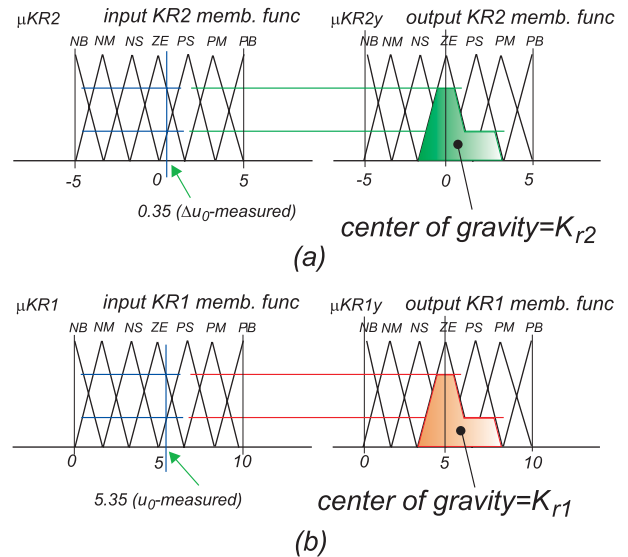

Fig. 6. Membership functions for K_{r1} and K_{r2} fuzzy systems.

4.1 Genetic tuning process of fuzzy controller

Genetic algorithms (GA) are stochastic search methods that mimics the metaphor of natural biological evolution. It is a class of optimization algorithm which borrows the ideas of evolution from the natural world and applies them to computational problem. This *artificial evolution* uses reproduction, mutation, and genetic recombination to evolve a solution to a problem. The first step in designing a GA is the decision which parts of the knowledge base are subject to optimization by the GA. The general structure of a FLC tuned with genetic algorithm is shown in Fig. 7 where every K_{rx} -block consists of input and output triangular functions. The GA is used for fast adaptation and tuning of FLC membership function according to several variables measured from the process. As criterium some dynamic properties of output voltage were prescribed. In our application all inputs and output membership functions are tuned. To decrease the number of tuned parameters certain constraints are imposed. The set of input and output membership functions:

$$\begin{aligned} \mu K_{r1i} &= (NB_{1i}, NM_{1i}, NS_{1i}, ZE_{1i}, PS_{1i}, PM_{1i}, PB_{1i}) \\ \mu K_{r1o} &= (NB_{1o}, NM_{1o}, NS_{1o}, ZE_{1o}, PS_{1o}, PM_{1o}, PB_{1o}) \\ \mu K_{r2i} &= (NB_{2i}, NM_{2i}, NS_{2i}, ZE_{2i}, PS_{2i}, PM_{2i}, PB_{2i}) \\ \mu K_{r2o} &= (NB_{2o}, NM_{2o}, NS_{2o}, ZE_{2o}, PS_{2o}, PM_{2o}, PB_{2o}) \end{aligned} \quad (9)$$

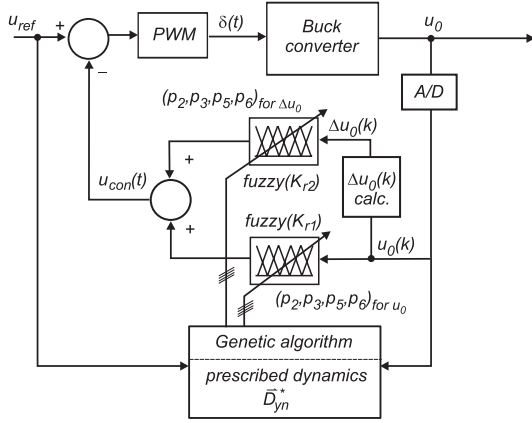

Fig. 7. Block diagram: genetic algorithm tuning of FLC.

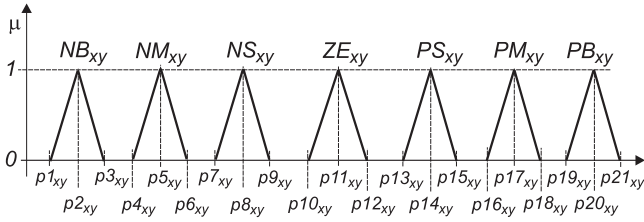

Fig. 8. Triangular membership function with characteristic parameters.

where *NB* means *negative big*, *NM* *negative middle*, ..., *ZE* *zero*, *PS* means *positive small*, ...and these function have triangular shape where the border points and center location of these membership functions are defined as shown in Figure 8. Center point of output *ZE* membership function is positioned at defined value (could be 0 or the middle point of region) while other borders and center locations ($p1_{xy} - p21_{xy}$) are included into chromosome and the values are chosen and rearranged in ascending order. Actually the chromosome is presented as a vector:

$$\vec{P} = [p_{i1}, p_{o1}, p_{i2}, p_{o2}] \quad (10)$$

where

$$p_{i1} = [p1_{i1}, p2_{i1}, \dots, p21_{i1}], \quad p_{o1} = [p1_{o1}, p2_{o1}, \dots, p21_{o1}], \\ p_{i2} = [p1_{i2}, p2_{i2}, \dots, p21_{i2}], \quad p_{o2} = [p1_{o2}, p2_{o2}, \dots, p21_{o2}],$$

Prescribed dynamics \vec{D}_{yn}^* (evident in Figs. 7 and 9) is expressed as a vector:

$$\vec{D}_{yn}^* = [A_{over}^*, t_r^*, t_{set}^*, e_{stat}^*] \quad (11)$$

where A_{over}^* is over-shoot, t_r^* is rise time, t_{set}^* is settling time and e_{stat}^* is static error of the closed loop system as shown Fig. 9. The vector of measured parameters, is expressed as:

$$\vec{D}_{yn} = [A_{over}, t_r, t_{set}, e_{stat}] \quad (12)$$

The task of GA is to find the vector \vec{P} which will minimize the difference between real "dynamics" vector and prescribed "dynamics" vector:

$$\vec{D}_{diff} = \vec{D}_{yn}^* - \vec{D}_{yn} \quad (13)$$

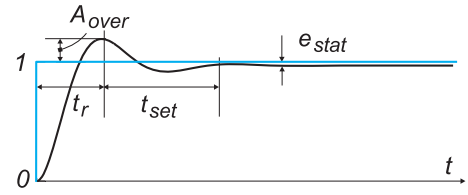

Fig. 9. Prescribed dynamics parameters for step response.

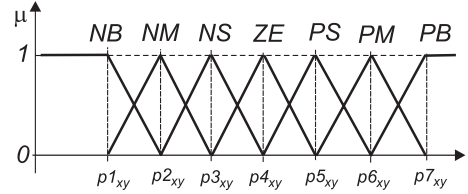

Fig. 10. Triangular membership function with reduced characteristic parameters.

The dynamic properties of closed loop system A_{over} , t_r , t_{set} and e_{stat} was obtained by simulation. So organized chromosome needs calculation of 44 elements and it is unappropriate for FPGA implementation. The GA procedure was optimized by using expert knowledge and the search algorithm was adapted at computation of the numbers follows from Fig. 10. The triangular function were chosen in a way that each number represents the middle point of previous function and the lower edge of next function. From the set of $\{p1_{xy} - p7_{xy}\}$ three points are defined in advance by control plant, $p1_{xy}$ (represents lower boundary), $p4_{xy}$ (is zero or reference voltage), and $p7_{xy}$ (represents upper boundary). So the others are adjusted by GA. For each fuzzy functions μK_{r1_i} , μK_{r1_o} , μK_{r2_i} and μK_{r2_o} four points are calculated, so vector (chromosome) of 16 elements is adjusted by GA in order to minimize \vec{D}_{diff} . In this way is evaluated the final values of chromosome vector \vec{P}_f determined by condition:

$$\vec{D}_{diff}(\vec{P}) = \min\{\vec{D}_{diff}(\vec{P}), \vec{P} \in \mathcal{S}\} \quad (14)$$

where \mathcal{S} is the set of all values for \vec{P} which are defined by physical properties of the process.

5. EXPERIMENTAL RESULTS AND DISCUSSION

The control of the Buck Converter is implemented on FPGA Cyclone II-ALTERA. Output voltage U_0 were converted using an analog-digital (A/D) converter with 8 bit resolution. The control algorithms are written in VERILOG language. The sample rate T_s of A/D conversion was $T_s = 5.33 \mu s$. In all experiments, the desired output is $U_{ref} = U_0 = 5 \text{ V}$ and the input voltage is $U_d = 12 \text{ V}$. First experiment was done in open-loop. The start-up response and the change of load resistance is shown in Fig. 11. The evaluated voltage ripple at converter output was 1 mV by formula, but due to quality of output capacitor (*ESR*-effect) the measured ripple was 10 mV. At time instant cca. $3.5 \mu s$ the load changed which manifested that current changes from 0.7 A to 1.25 A. The voltage drop is evident from the voltage response from 5 V to 4.65 V. The second experiment was done in closed-loop operation. The Fuzzy state controller was implemented in order to control

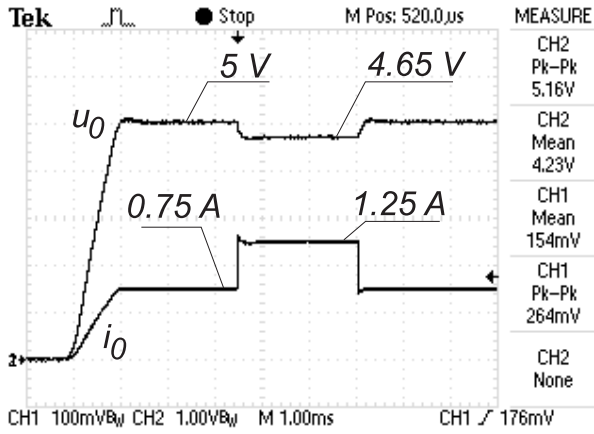

(a)

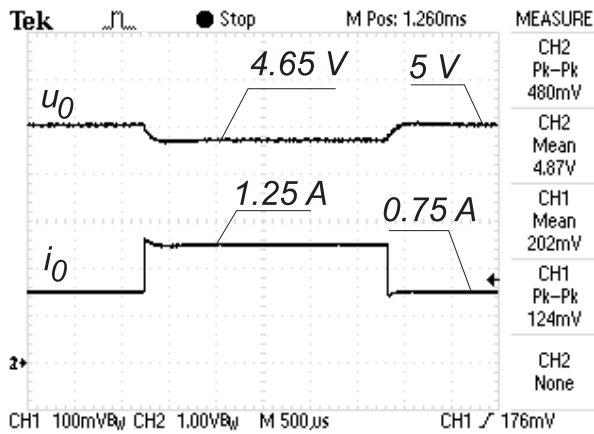

(b)

Fig. 11. Open loop response.

output voltage. Fig. 12 shows the start-up and load change response. At time instant $3.5 \mu s$ the load changes and it manifested that current changes from 0.7 A to 1.4 A. The voltage drop is not evident from response. The dynamic error was less than $\pm 2\%$.

6. CONCLUSION

The results presented in the paper show the convenience of applying fuzzy control to dc/dc converter control as an alternative to conventional techniques. Genetic algorithms are a valuable tool for the fuzzy controller tuning. An evolutionary strategy is applied to tune the input and output membership functions of a fuzzy controller. This algorithm was ran under the MATLAB Genetic Algorithm Toolbox. The evaluated boundaries of fuzzy sets function were afterwards implemented on the FPGA. The genetic tuning process was able to reduce the overshoots at startup and over/under-shoots at the load change. Non-linear gains ($K_{r,1}$ and $K_{r,2}$) were calculated as center of gravities of chosen input and output membership functions in a real time. For this task the FPGA unit spend $50 ns$ to $140 ns$. The experimental set is open for testing the another digital non-linear controllers.

REFERENCES

R.D. Middlebrook, S. Čuk A General Unified Approach to Modeling Switching Power Stages. *IEEE Power*

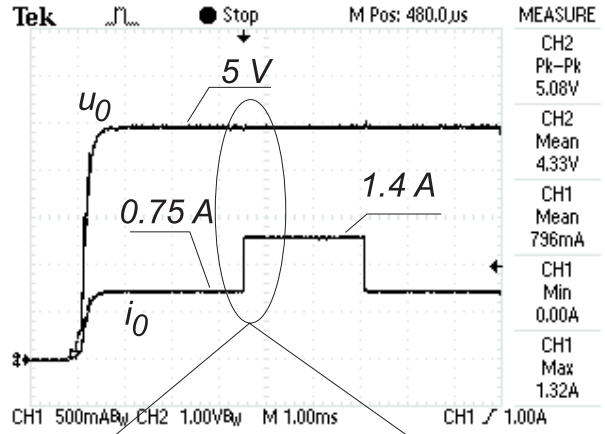

(a)

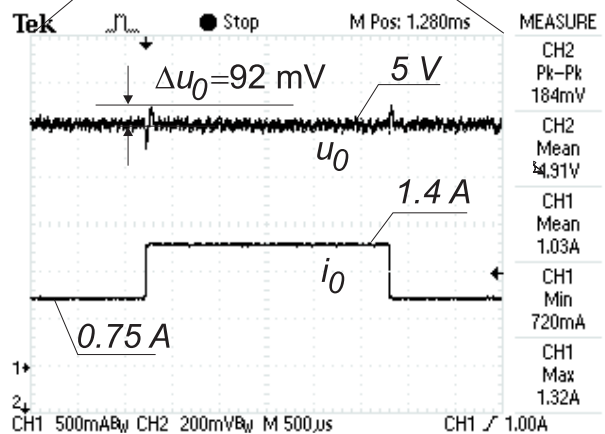

(b)

Fig. 12. Closed loop response.

Electronics Specialist Conference-PESC77, pp. 36-37, May. 1977.
 W.-C. So, C. K. Tse, Y-S. Lee Development of a fuzzy logic controller for DC/DC converters: design, computer simulations, and experimental evaluation. *IEEE Trans.Power Electronics*, vol. 11, no. 1, Jan. 1996.
 T.J. Ross. *Fuzzy logic with engineering applications*. John Wiley and Sons, Ltd., The Atrium, Southern Gate, Chichester, West Sussex, England, 2004.
 M. Milanović, M. Truntiĉ, P. Šlibar, and D. Dolinar. Development of a fuzzy logic controller for DC/DC converters: design, computer simulations, and experimental evaluation. *Microelectronics reliability*, vol. 47, no. 1, pp. 150-154, Jan. 2007.
 S. Čuk, R.D. Middlebrook *Basic of switched-mode power conversion: Topologies, magnetics, and control, Advanced in switching Mode Power Conversion*. Pasadena, CA, TESLaco 1981, vol. 2, pp. 279-310, 1981.
 M. Milanovic, D. Gleich. Buck converter digitally controlled by a fuzzy state-space controller. *HAIT Journal of Science and Engineering B*, Volume 2, Issue 5-6, pp. 638-654, 2005.
 T. Takagi, and M. Sugeno, Fuzzy Identification of System and Its Applications to Modelling and Control. *IEEE Transactions on Systems, Man and Cybernetics*, Vol.15, pp 116-132, Jan. 1985.