

Displacement Sensor Fault Tolerance for Hydraulic Servo Axis

Marco Muenchhof*

* *Technische Universitaet Darmstadt, Institute of Automatic Control, Laboratory for Control Systems and Process Automation, Darmstadt, Germany (Tel: +49-6151-16-3114; e-mail: MMuenchhof@iat.tu-darmstadt.de).*

Abstract: In this paper, a fault management system for a hydraulic servo axis is described. This system is capable of sustaining faults in the piston displacement sensor of the position-controlled hydraulic servo axis. By means of a parity equation based fault detection stage, faults in the displacement sensor as well as other sensors and components of the servo axis can be detected and subsequently be diagnosed by means of a fuzzy-logic based reasoning system. Upon the diagnosis of a piston displacement sensor fault, the system switches to a “model-sensor” which provides an estimate for the piston position. To ensure the utmost model fidelity of the model sensor, the model parameters are constantly updated by means of parameter estimation during the fault-free operation of the servo axis. Experiments at a hydraulic servo axis conclude this paper and show the high quality of the reconstructed piston displacement sensor signal.

Keywords: Hydraulic Actuators, Fault Diagnosis, Fault Tolerance, Sensor Failures, Physical Models, Parameter Estimation

1. INTRODUCTION

There are in general two ways to achieve a high system availability, *perfectness* and *fault tolerance*. Perfectness means that one has to oversize all components and introduce stringent quality control procedures. Despite these efforts, one can still not deny all faults. There may still exist unforeseen events leading to faults during operation of the component as well as flaws in the quality control procedures, allowing imperfect components to leave the factory and enter the market. In contrast to perfectness, fault tolerance, see e.g. Lee and Anderson [1990], takes the occurrence of faults into consideration at the design stage. It is accepted that faults can happen, but the system is equipped with countermeasures to limit the impact of a fault.

Fault tolerance can be achieved in several ways: Typical approaches for sensor fault tolerance are *hardware redundancy* and/or *analytical redundancy*. In hardware redundancy, two or more sensors of the same or better yet diverse measuring principles are operated in parallel. A voter structure or an integrated fault detection and diagnosis mechanism allows to separate the faulty from the fault-free measurements and thus provides a consolidated signal. A detailed discussion for the application of diverse measuring principles as well as voter schemes for a fault tolerant brake-by-wire pedal can be found in Isermann et al. [2000]. The use of hardware redundancy will however lead to increased cost (for the additional sensors, wiring, etc.) and will thus be limited to applications with the highest safety-demands, e.g. aircrafts, railways and such. In hydraulic systems, fault management methods will mostly only be acceptable if they can operate with the series instrumentation, see Hammn and Bork [2005].

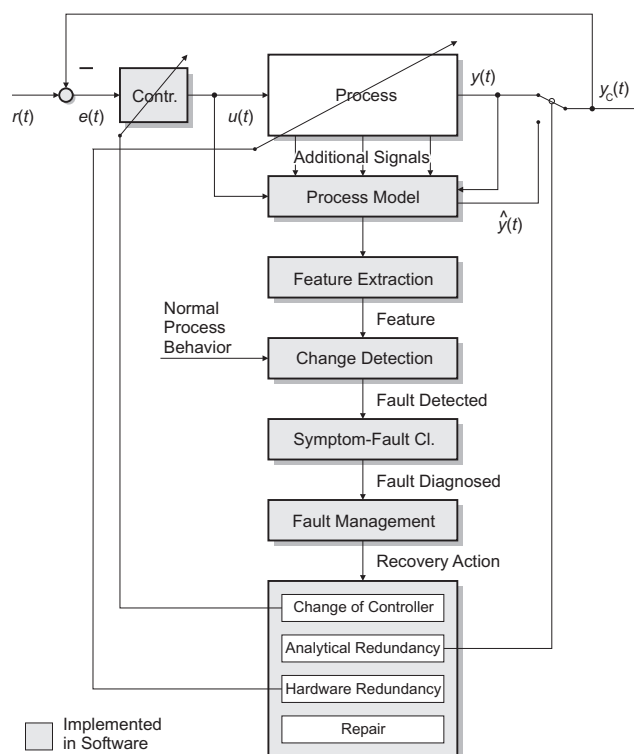

Fig. 1. General Scheme of a Fault Management System

Hydraulic servo axes are typically employed in one of the two operating modes, *force-controlled* or *position-controlled*. In piston-controlled mode, the feed-back quantity is obviously the piston displacement, which is measured by a displacement sensor. If the sensor fails and there is no integrated fault management stage capable of dealing

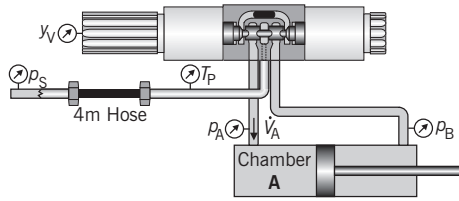

Fig. 2. Schematic Drawing of Hydraulic Servo Axis along with Sensor Location

with sensor faults, the servo axis must be shut down and repaired.

By the application of modern fault management techniques, as discussed in this paper, the servo axis can maintain operation even in the presence of a displacement sensor fault or even total loss of the displacement sensor signal. Figure 1 presents the general scheme of a fault management system. Faults in the system are detected by means of *model-based fault detection* techniques. For these methods, a process model, which is driven by the process inputs and outputs as well as additional signals, is evaluated and so-termed *features* are generated. The physical modeling of the hydraulic servo axis is shortly described in Sec. 2. The generated features can be physical parameters as e.g. a resistance, a friction coefficient and so on, but can also be *residuals*, i.e. deviations between the output of the process and a process model. A detailed description of the theory of the different fault detection and diagnosis methods can e.g. be found in Isermann [2006] or Patton et al. [2000].

In the next step, the features are compared with the *normal process behavior*. Features that do not fall within the interval typical for the normal process operation are called *symptoms*. As soon as any symptoms occur, the fault management system can indicate the presence of a fault to the user, which means that the *fault has been detected*. See Sec. 3.1 for the application of fault detection techniques to the hydraulic servo axis. The symptoms are next subjected to a *symptom-fault classification* and the fault currently present in the system is *diagnosed*. The setup employed at the servo axis is described in Sec. 3.2.

Finally, the *fault management* stage must initiate some recovery action. In the easiest case, this can be a change of controller parameters or a change of the controller structure, Blanke et al. [2003], Zhang and Jiang [2003]. In the case of sensor faults, the fault management system can employ so-termed *analytical redundancy*. The individual sensor readings at a process are not random but are determined by the process characteristics and process dynamics. If one sensor fails, its reading can be determined by the aid of an analytical model which is driven by other (still intact) sensors. This approach is utilized in this paper and is developed in Sec. 3.3. Other recovery actions can include the use of hardware redundancy, controller reconfiguration (Niksefat and Sepeheri [2001], Bu and Yao [2001]), or repair.

2. PHYSICAL MODEL OF THE HYDRAULIC SERVO AXIS

Figure 2 shows a schematic drawing of the hydraulic servo axis along with the sensor locations. The servo axis is

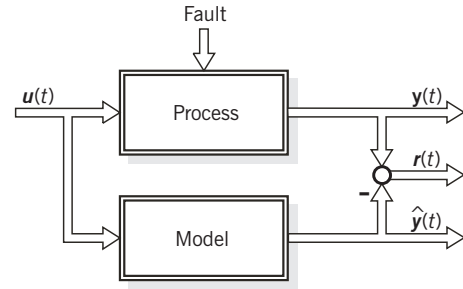

Fig. 3. Scheme of Parity Equation

equipped with a pressure sensor measuring the pressure at the outlet of the pressure supply (p_S), two cylinder chamber pressure sensors (p_A and p_B), a fluid temperature sensor (T_P) as well as a valve spool displacement sensor (y_V) and a piston displacement sensor (y). A detailed description of hydraulic components along with their modeling can be found in Isermann [2003]. The flow over the control edges inside the direct driven proportional valve is modeled as a turbulent flow. The flow to/from chamber A, \dot{V}_A is thus given as

$$\dot{V}_A(t) = \begin{cases} b_{V1}(y_V, T_P) \sqrt{|p_S(t) - p_A(t)|} \dots \\ \dots \text{sign}(p_S(t) - p_A(t)) \text{ for } y_V(t) > 0 \\ b_{V1}(y_V, T_P) \sqrt{|p_A(t)|} \text{sign}(p_A(t)) \text{ for } y_V(t) < 0 \end{cases} \quad (1)$$

Although p_A may never be negative, the absolute value is taken to easily deal with outliers or measurement noise.

In (refeq:firstbvequation), $b_{V1}(y_V, T_P)$ is the coefficient of valve flow, which depends on both the valve spool displacement y_V and the fluid temperature T_P . Since the valve spool shows a non-linear displacement-flow relation, the coefficient of valve flow should not be modeled employing a linear model but should rather be modeled as a polynomial of order 3,

$$b_{V1}(y_V, T_P) = \begin{cases} a_{02}(T_P) + a_{12}(T_P)y_V(t) + a_{22}(T_P)y_V^2(t) \dots \\ \dots + a_{32}(T_P)y_V^3(t) \text{ for } y_V(t) > 0 \\ a_{01}(T_P) + a_{11}(T_P)y_V(t) + a_{21}(T_P)y_V^2(t) \dots \\ \dots + a_{31}(T_P)y_V^3(t) \text{ for } y_V(t) < 0 \end{cases} \quad (2)$$

which has two separate branches for $y_V > 0$ and $y_V < 0$. The valve flow characteristics vary drastically from design to design which also motivates to use a general polynomial model, since for such a model, almost no a-priori assumptions have to be made and thus a wide variety of different designs can be accommodated.

The hydraulic cylinder is a differential cylinder with a one sided piston rod. The flow balance of the cylinder is given as

$$\dot{V}_A(t) = A_A \dot{y}(t) - G_{AB}(T_P) (p_A(t) - p_B(t)) \dots \\ \dots - \frac{\dot{p}_A(t)(V_{0A} + A_A y(t))}{E_{0A}(T_P)} \quad (3)$$

where $G_{AB}(T_P)$ is the coefficient of laminar leakage flow between chamber A and B and $E_{0A}(T_P)$ is the bulk modulus of the fluid enclosed in chamber A. V_{0A} is the dead volume and A_A the cross-sectional area of chamber A.

The flow balance (3) is now solved for the piston velocity,

$$\dot{y}(t) = \frac{1}{A_A} \left(\dot{V}_A(t) - G_{AB}(T_P)(p_A(t) - p_B(t)) \dots \dots - \frac{\dot{p}_A(t)(V_{0A} + A_A y(t))}{E_{0A}(T_P)} \right) \quad (4)$$

This model can be integrated over time to obtain the piston position $y(t)$. As this model does only provide an estimate for the piston position, its output will be denoted $\hat{y}(t)$ from now on. The temperature dependency of the system parameters will be taken into account in the “soft-sensor” by a permanent update of the model parameters by means of parameter estimation during fault-free operation. For the parity equation itself, different sets of system parameters for different fluid temperatures have been determined by measurements at the time of the initiation of the hydraulic servo axis.

3. FAULT MANAGEMENT

As described in Sec. 1, the typical stages of a fault management system are fault detection, fault diagnosis and in the case at hand, the use of analytical redundancy to maintain operation despite the presence of a displacement sensor fault.

3.1 Fault Detection

Fault detection is based on parity equations. The concept of parity equations means that a model is operated in parallel to the process. If the model is of sufficient fidelity, the model and plant output will be similar and their difference close to zero. If a fault occurs and it influences the behavior of the process with respect to the compared quantity, then there will be a deflection of the residual as there is a difference between the model output and the plant output, see Fig. 3. Based on the dynamics for chamber A and chamber B as well as different sensor configurations, a total of five parity equations can be obtained. These are

$$r_1(t) = y(t) - \hat{y}_1(p_P(t), p_A(t), p_B(t), T_P(t), y_V(t)) \quad (5)$$

$$r_2(t) = y(t) - \hat{y}_2(p_S(t), p_A(t), p_B(t), T_P(t), y_V(t)) \quad (6)$$

$$r_3(t) = y(t) - \hat{y}_3(p_P(t), p_A(t), p_B(t), T_P(t), y_V(t)) \quad (7)$$

$$r_4(t) = y(t) - \hat{y}_4(p_S(t), p_A(t), p_B(t), T_P(t), y_V(t)) \quad (8)$$

$$r_5(t) = y(t) - \hat{y}_5(p_A(t), p_B(t), T_P(t), y_V(t)) \quad (9)$$

In these equation p_P denotes an additional pressure sensor at the valve port P. The system is capable of detecting single faults in all sensors. A more detailed description can be found in Muenchhof [2006a]. There, also the tuning of the thresholds will be discussed in detail. An assessment of the performance has shown that sensor faults in the area of 1% of the maximum sensor reading can be detected.

3.2 Fault Diagnosis

A fuzzy-logic based reasoning system is employed to classify the type of fault from the symptoms supplied by the parity equations. The different process and sensor faults manifest themselves in different patterns of deflected and unaffected residuals. The value of each residual is classified according to the classes “reduced”, “normal”, and

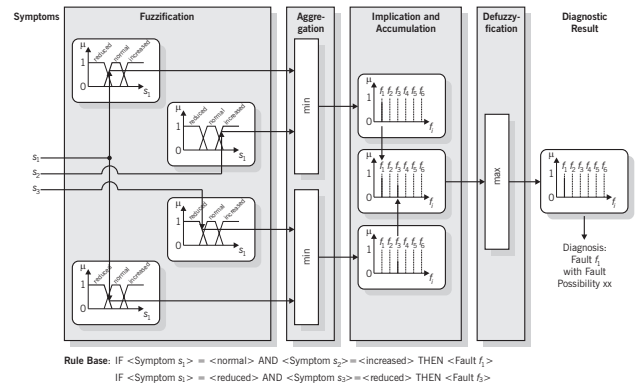

Fig. 4. Scheme for Fault Diagnosis

Fault	r1	r2	r3	r4	r5
Fault Free	0	0	0	0	0
Supply Line Congest.	-	-	+	+	0
Return Line Congest.	+	+	-	-	+
Internal Leakage	-	-	+	+	0
Sensor Offset +ΔpA	+	+	0	0	+
Sensor Offset -ΔpA	-	-	0	0	-
Sensor Offset +ΔpB	0	0	-	-	-
Sensor Offset -ΔpB	0	0	+	+	+
Sensor Offset +ΔpP	-	0	+	0	0
Sensor Offset -ΔpP	+	0	-	0	0
Sensor Offset +ΔpS	0	-	0	+	0
Sensor Offset -ΔpS	0	+	0	-	0
Sensor Offset +Δy	+	+	+	+	+
Sensor Offset -Δy	-	-	-	-	-

0:Normal +:Increased -:Decreased

Table 1. Fault-Symptom Table

“increased”. Fuzzy logic is used to reproduce the fuzzy transitions between the different states in the reasoning process. A Fuzzy-AND operator is used to combine the deflection of individual residuals into the distinctive patterns. The underlying fault-symptom-table is shown in Tab. 1. This Fuzzy Logic-based reasoning system has been chosen because of its intuitive design, which mimics the human decision process well. Furthermore, since it works with fuzzy information instead of crisp numbers, it is well adapted to the diagnosis problem, where one typically has to deal with uncertain information, e.g. only slight violations of thresholds, false reaction of one symptom and such.

3.3 Fault Tolerance by Analytical Redundancy

In the case of a displacement sensor fault, the sensor signal $y(t)$ shall be replaced by an estimate $\hat{y}(t)$ which is determined based on the physical model described in (2) as well as (4). During the fault free operation of the sensor, the piston displacement as measured is passed on as the consolidated piston position signal $y_C(t)$, see Fig. 5.

In contrast to Muenchhof [2006b], the model parameters are constantly updated by parameter estimation Isermann [1991] in this realization of a fault-tolerant position sensing system. (4) is split into two equations, one for positive valve spool displacements ($y_V > 0$) and one for negative valve spool displacements ($y_V < 0$). The resulting two equations are

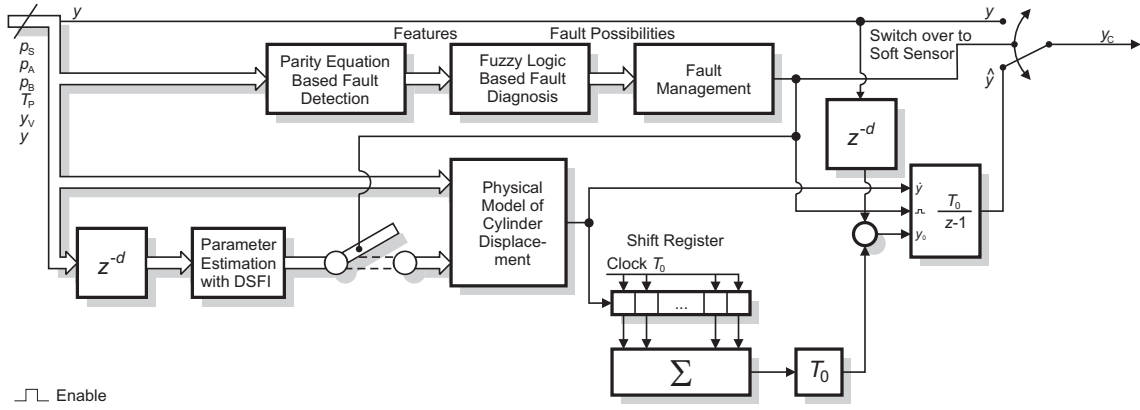

Fig. 5. Detailed View of Functional Blocks for Fault Management

$$\begin{aligned}
 & a_{02} \sqrt{|p_S - p_A|} \cdot \text{sign}(p_S - p_A) \dots \\
 & \dots + a_{12} y_V \sqrt{|p_S - p_A|} \cdot \text{sign}(p_S - p_A) \dots \\
 & \dots + a_{22} y_V^2 \sqrt{|p_S - p_A|} \cdot \text{sign}(p_S - p_A) \dots \\
 & \dots + a_{32} y_V^3 \sqrt{|p_S - p_A|} \cdot \text{sign}(p_S - p_A) \dots \\
 & \dots - G_{AB}(p_A - p_B) - \kappa_A \dot{p}_A (V_{0A} + A_A y) = A_A \dot{y}
 \end{aligned} \quad (10)$$

and

$$\begin{aligned}
 & a_{02} \sqrt{|p_A|} \cdot \text{sign}(p_A) \dots \\
 & \dots + a_{12} y_V \sqrt{|p_A|} \cdot \text{sign}(p_A) \dots \\
 & \dots + a_{22} y_V^2 \sqrt{|p_A|} \cdot \text{sign}(p_A) \dots \\
 & \dots + a_{32} y_V^3 \sqrt{|p_A|} \cdot \text{sign}(p_A) \dots \\
 & \dots - G_{AB}(p_A - p_B) - \kappa_A \dot{p}_A (V_{0A} + A_A y) = A_A \dot{y}
 \end{aligned} \quad (11)$$

where κ_A denotes the inverse of the bulk modulus E_A .

Since (10) and (11) are linear in parameters, a Least Squares parameter estimation approach can be used to determine the model parameters. A recursive DSFI algorithm is employed to make an update available after each sample step. To account for time variance of the parameters, a forgetting factor $\lambda < 1$ is introduced.

One problem which might affect the parameter estimates negatively is the time lag between the onset of the fault and the detection of the fault by the fault detection stage. In the time period between the onset and the detection, faulty measurements might contribute to the parameter estimation. To avoid this, the measurements supplied to the parameter estimation stage are delayed by d samples. If the fault is detected within d samples after its emergence, no faulty measurements are employed for the model parameterization.

In the case of a fault, the system switches over to the "soft-sensor" as sketched in (4): The physical model of the cylinder displacement is initialized with the parameter estimates and then evaluated periodically to update the position estimate. At the same time, the parameter estimation is stopped since the signal $\dot{y}(t)$ which is required for parameter estimation is no longer available from the sensor.

The output of the physical model of the cylinder displacement is an estimate for the piston velocity, $\hat{y}(t)$. It must be integrated over time. This task is carried out by the discrete time integrator $G_I(z)$ with the transfer function

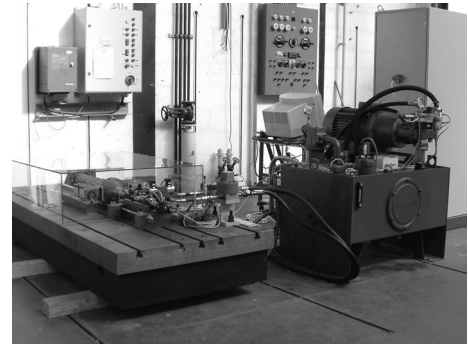

Fig. 6. View of Testbed

$$G_I(z) = \frac{T_0}{z - 1} \quad (12)$$

where T_0 is the sample time. If the fault management switches over to the analytical redundancy, the integrator is enabled. At this point, an initial condition, i.e. initial displacement y_0 , must be supplied to the integrator. As there might be a time lag between the emergence and the detection of a piston displacement sensor fault, it is not advisable to use the latest available piston displacement measurement as an initial condition. Rather, the piston displacement $y(t - dT_0)$ measured d samples ago is used. The velocity estimates \hat{y} as determined for the time steps $t - dT_0$ up to $t - T_0$ are integrated and added to the piston displacement $y(t - dT_0)$. This operation is written as

$$y_0(t) = y(t - dT_0) + \sum_{i=-d}^{-1} \hat{y}(t - iT_0) \cdot T_0 \quad (13)$$

This functionality is realized by a shift register, which stores the last d values of $\hat{y}(t)$ and a subsequent summation and scaling with the gain T_0 .

4. EVALUATION AT TESTBED

The algorithm has been tested exhaustively at a testbed. The testbed consists of a swash plate axial piston pump which supplies the hydraulic pressure to an electrohydraulic servo axis made up of a direct acting proportional valve and a differential cylinder. The supply pressure is $p_S = 80$ bar. A photo of the testbed is shown in Fig.6.

During fault free operation, the recursive DSFI algorithm permanently estimates the parameters of the model of the

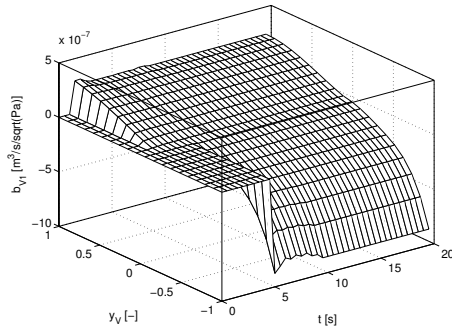

Fig. 7. Estimation of the Valve Flow Characteristics

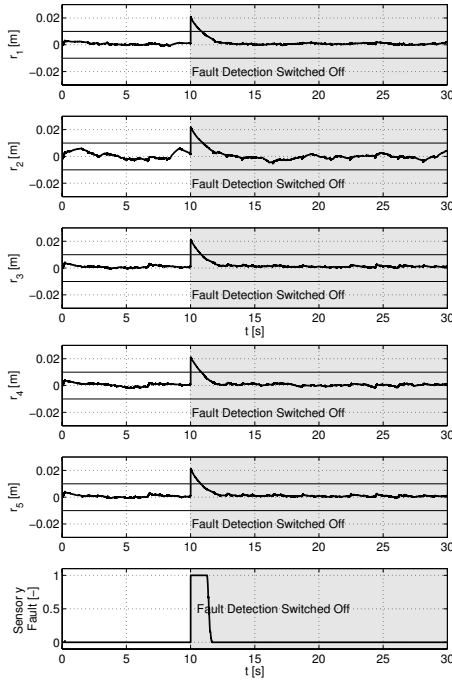

Fig. 8. Diagnosis of Offset Fault on y

hydraulics in chamber A. Figure 7 shows the estimation of the valve flow characteristics. The parameter estimation algorithm waits for a certain number of data pairs before beginning to supply estimates. Thus, the estimated valve characteristics for both branches ($y_V > 0$ and $y_V < 0$) are zero at the beginning. One can see that the estimation converges rapidly. In a similar manner, the bulk modulus and the laminar leakage flow are evaluated.

At $t = 10$ s, a displacement sensor offset fault of $\Delta y = 2$ cm is introduced into the system. The effect of this fault is illustrated in Fig. 9. In the diagnosis plot (Fig. 8), one can see the behavior of the five residuals. The thin horizontal lines denote the boundaries between the fault-free and the faulty case. The residuals first remain close to zero indicating that the system is indeed fault free. At $t = 10$ s, the offset fault is injected and instantaneously, all residuals react to the fault and deflect. As all residuals deflect positively, the diagnostic system infers a positive sensor offset fault of the piston displacement sensor based on the fault-symptom table shown in Tab. 1.

The fault management system now switches from the real sensor to the "soft-sensor". The consolidated sensor signal $y_C(t)$ is from now on generated by means of analytical

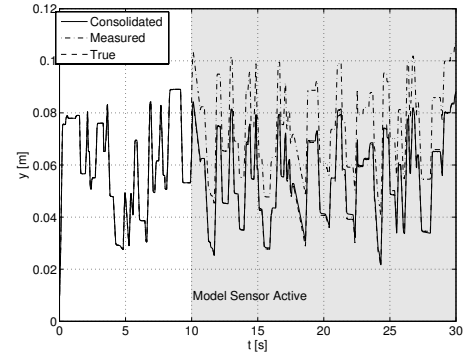

Fig. 9. Consolidated Signal $y_C(t)$

redundancy from other sensor signals. Figure 9 illustrates the high fidelity of the consolidated signal. During the first ten seconds, the measured signal is passed through, i.e. $y_C(t) = y(t)$. At the occurrence of the fault, the displacement sensor signal becomes erroneous and is offset by 2 cm from the true piston position. The fault management system switches to the model sensor, i.e. $y_C(t) = \hat{y}(t)$ to obtain more precise information about the current piston displacement than would be possible with the erroneous sensor.

The switchover to the soft-sensor is permanent as the fault detection and diagnosis system is currently only capable of detecting single faults and thus cannot detect further faults once the piston displacement sensor has failed. Two questions that arise in the use of the soft-sensor are the initial condition and the stability of the system. The initial condition must not be affected by the fault, thus the position readout d samples ago and projected by means of the model forward to the current time step is used. As the soft-sensor uses an open integrator it is by definition susceptible to drifting. In the experiments, the soft-sensor has shown sufficient long-term stability. Furthermore, by driving the piston into the displacement limits, the integrator can always be reset to a known position value.

5. CONCLUSION AND OUTLOOK

In this work, a fault management system for a hydraulic servo axis has been developed. Figure 10 shows a summary of this work. Driven by measurements of the supply pressure, the chamber pressures, the fluid temperature as well as the valve spool and piston displacement, parity equations based on the dynamics of the hydraulic servo axis are employed for fault detection. They are augmented by a parameter estimation approach which can be used for both, fault detection as well as parameterization of the "soft-sensor". The symptoms generated by the fault detection stage are passed on to the fault diagnosis stage, which in the case at hand was realized as a fuzzy logic-based inference system. Its diagnosis is supplied to the fault management system, which then decides on an appropriate recovery action. Such actions can be the change of controller parameters or the controller structure, the application of analytical or hardware redundancy or in the worst case the shutdown and repair of the hydraulic servo axis. In this paper, analytical redundancy is employed to be able to tolerate faults on the piston displacement

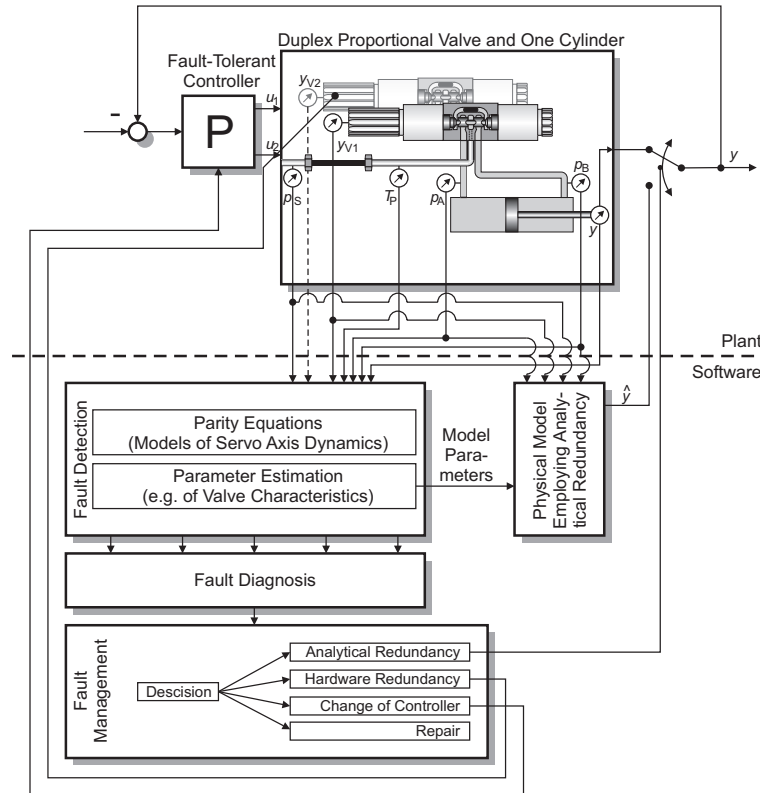

Fig. 10. View of Fault Tolerant Hydraulic Servo Axis

sensor. In the case of a fault, the fault management system switches over from the position sensor to a physical model providing an estimate for the piston position $\hat{y}(t)$. Some other remedial actions for fault tolerance against various faults are sketched in Fig. 10: Currently, a second valve (drawn in light colors) is mounted at the testbed to introduce hardware redundancy into the testbed and to allow the investigation of the fault management of valve faults. Also, one can think about changing the controller structure or controller parameters in the case of a fault. This shall also be investigated in the future.

ACKNOWLEDGEMENTS

This research work has been supported under grant AiF 14990 from budgetary resources of the German Bundesministerium für Wirtschaft und Technologie (BMWi) by the Arbeitsgemeinschaft industrieller Forschungsvereinigungen Otto von Guericke e. V. (AiF). The closing report will be available from the Deutsche Forschungsgesellschaft für Automatisierung und Mikroelektronik DFAM e. V.. Furthermore, this research work was supported by Bosch Rexroth AG, Lohr am Main, Germany.

REFERENCES

M. Blanke, M. Kinnaert, J. Lunze, and M. Staroswiecki. Concepts and methods in fault tolerant control. In *Proceedings of the 2003 SAFEPROCESS*, Washington, DC, 2003.

Fanping Bu and Bin Yao. Desired compensation adaptive robust control of single-rod electro-hydraulic actuator. In *Proceedings of the 2001 ACC*, Arlington, VA, 2001.

Wolfgang Hammn and Wilfried Bork. O+P Gespraech condition monitoring. *O+P*, 2, 2005.

R. Isermann, R. Schwarz, and S. Stoelzl. Fault tolerant drive-by-wire systems – concepts and realization. In *Proceedings of the 2000 SAFEPROCESS*, Budapest, 2000.

Rolf Isermann. *Fault Diagnosis Systems*. Springer-Verlag, Berlin, 2006.

Rolf Isermann. *Identifikation Dynamischer Systeme Band 1 und 2*. Springer-Verlag, Heidelberg, 1991.

Rolf Isermann. *Mechatronic Systems : Fundamentals*. Springer Verlag, UK, 2003. ISBN 1-852-33693-5.

P. Lee and T. Anderson. *Fault Tolerance – Principles and Practice*. Springer-Verlag, Berlin, 1990.

Marco Muenchhof. *Model-Based Fault Detection for a Hydraulic Servo Axis, Nummer 1105 in Fortschritt-Berichte VDI Reihe 8*. VDI-Verlag, Dsseldorf, 2006a. ISBN 3-18-510508-7.

Marco Muenchhof. Fault-management for a smart hydraulic servo axis. In *Proceedings of the Actuator 2006*, Bremen, 2006b.

Navid Niksefat and Nariman Sapeheri. Fault tolerant control of electrohydraulic servo positioning system. In *Proceedings of the 2001 ACC*, Arlington, VA, 2001.

R. J. Patton, P. M. Frank, and R. N. Clark. *Issues of Fault Diagnosis for Dynamic Systems*. Springer-Verlag, Berlin, 2000.

Youmin Zhang and Jin Jiang. Bibliographical review on reconfigurable fault-tolerant control systems. In *Proceedings of the 2003 SAFEPROCESS*, Washington, DC, 2003.