

## Fuzzy Petri Nets Based Rescheduling Model for Semiconductor Production and its Application

Fei Qiao\* Qidi Wu \*\* Li Li\*\*\* Zuntong Wang\*\*\*\* Zhengcai Cao\*\*\*\*\*

\*CIMS Research Center, Tongji University, Shanghai, 201804 P.R. China  
(Tel: +86 21 69589358; e-mail: fqiao@mail.tongji.edu.cn).

\*\* CEIE, Tongji University, Shanghai, China (e-mail: wuqidi@mail.tongji.edu.cn)

\*\*\* Tongji University, Shanghai, China (e-mail: lili@mail.tongji.edu.cn).

\*\*\*\* Tongji University, Shanghai, P.R. China (e-mail: wangzt@mail.tongji.edu.cn).

\*\*\*\*\* CIMS Center, Tongji University, Shanghai, China (e-mail: giftczc@163.com).

---

**Abstract:** The rescheduling strategy of semiconductor production refers to deciding when to start a rescheduling procedure and what kind of rescheduling method to be adopted. Both of the two problems are ill-structured and involve some fuzzy and random information. In order to solve this kind of production problem, a fuzzy Petri nets based rescheduling model (FPN-R) is proposed. FPN-R is defined as a 7-tuple, which includes an additional threshold parameter. Based on FPN-R, the fuzzy reasoning approach for rescheduling decision-making is further discussed. At last, an example of rescheduling strategy problem from semiconductor manufacturing is illustrated to show the application and feasibility of the proposed model and reasoning approach.

**Key Words:** rescheduling; rescheduling strategy; fuzzy reasoning; Petri nets; semiconductor production

---

### 1. INTRODUCTION

Today's rapid development of market economy has put manufacturing enterprises under more stress from customers who require higher product quality and shorter lead time. In order to satisfy even more rigorous customers and market, production managers must rely on a realistic and feasible production schedule. Due to the high possibility of uncertain production disturbances either from external market environments or from internal factory circumstances, production rescheduling has become an urgent issue (Li *et al.*, 2000).

According to Olumolade and Norrei, Production rescheduling refers to the process in which, when the original production schedule is disturbed in the course of its operation, a new schedule adapted to the present conditions is laid down on the basis of the original one (Olumolade *et al.*, 1996). Present researches on rescheduling mainly consist of rescheduling strategy and rescheduling method. The former deals with when to start a rescheduling procedure and what kind of rescheduling method should be adopted. And the later deals with updating or generating new schedule upon the original schedule under the changed production environment and conditions.

This paper will focus on the first rescheduling problem, and be organized as follows. Section 2 analyzes rescheduling strategy of semiconductor production and its two aspects. Section 3 defines a fuzzy Petri nets model (FPN-R) for describing rescheduling problem. How to make the rescheduling decision by fuzzy reasoning based on FPN-R is

discussed in section 4. Section 5 gives an example to illustrate the application of proposed FPN-R and its reasoning approach. And Section 6 provides some conclusions of whole paper.

### 2. RESCHEDULING STRATEGY FOR SEMICONDUCTOR PRODUCTION

The rescheduling strategy is to answer two questions. One is when to start rescheduling procedure, which is called as rescheduling start-up decision. The other is what kind of rescheduling method should be used, that is the rescheduling method selection

#### 2.1 Rescheduling Start-up Decision

In order to determine when to start a rescheduling procedure, it is necessary to effectively monitor internal and external production environment and recognize various disturbances, such as machine breakdown, rush order release, customer's request for an urgent delivery date, etc. Sometimes further analysis of certain important disturbance or relation and synthesis between different disturbances are also required.

From the literatures there are three types of rescheduling policies: periodic, event-driven and hybrid, to address the rescheduling start-up decision problem (Vieira *et al.*, 2002).

Following the periodic policy, rescheduling will be started at regular intervals, as Church and Uzsoy have explained in detail in (Church and Uzsoy, 1992). Though this periodic approach yields more rescheduling stability and is easy to

implement, its ability to respond to production uncertain disturbances is limited. Determining the optimal rescheduling interval is also a difficult task.

Event-driven policy triggers rescheduling once any disturbance event, such as machine failure or rush order arrival occurs. For example, Abumaizar and Suestka, J.A. used this strategy to reschedule the system when machine failures occur (Abumaizar *et al.*, 1997). Bierwirth and Mattfeld studied event-driven rescheduling policy that creates a new schedule every time a new job arrives (Bierwirth and Dirk, 1999). While this event-driven rescheduling policy can give quick response to dynamic production system, it usually causes high nervousness, low stability and excessive computational requirements, especially in large facilities with many events occurring in rapid succession.

Combining above-mentioned two policies, the hybrid rescheduling policy reschedules production system periodically and also responds to the disturbance events happened between two periodical rescheduling points, as the research work by Vieira, G.E. *et al.* (Vieira *et al.*, 2000) and the work by Qiao *et al.* (Qiao *et al.*, 2007).

### 2.2 Rescheduling Method Selection

Once the rescheduling start-up decision has been made, an appropriate rescheduling method should be chosen to execute rescheduling procedure. There are many rescheduling methods which have been studied in literatures (Bierwirth and Dirk, 1999, Church and Uzsoy, 1992, and Vieira *et al.*, 2000 and 2002). To summarize them, two rescheduling method categories can be concluded: partial rescheduling and regeneration rescheduling. The former reschedules only the operations affected directly or indirectly by the disruption. This method preserves original schedule as much as possible, and tends to maintain schedule stability. The later one reschedules the entire unprocessed operations no matter being affected by the disruption or not (Vieira.*et al.*, 2002). The idea of this method is to seek optimization with the risk of losing computational efficiency and satisfactory response time.

For individual production rescheduling problem, normal solution is to use one kind of rescheduling method at any rescheduling point and under any production circumstance. Since different rescheduling methods have different advantages and disadvantages, it is better to make a choice at each rescheduling point considering the actual status at the time. This is another decision to be made by rescheduling strategy.

## 3. FUZZY PETRI NETS MODEL FOR SEMICONDUCTOR RESCHEDULING

Fuzzy Petri nets (FPN) (Chen *et al.*, 1990, Jia *et al.*, 2003, Li and Lara-Rosano, 2000) is a model of knowledge based system, which can be used for fuzzy knowledge representation and reasoning. According to literature plenty of applications of FPN address problems like fault diagnosis, fuzzy reasoning, uncertainty management,

knowledge learning, etc. In order to describe the combined rescheduling strategy problem, which is composed of rescheduling start-up decision and rescheduling method selection, a new fuzzy Petri nets model for rescheduling (FPN-R) of semiconductor production will be defined. And how to use FPN-R model based reasoning to make the rescheduling decision will be discussed in the next section.

### 3.1 Fuzzy Petri Nets Model for Rescheduling(FPN-R)

The FPN-R can be defined as a 7-tuple:

$$FPN-R = \{P, T, I, O, \tau, \gamma, S_0\} \quad (1)$$

Here,  $P = P_U \cup P_D$  denotes a set of places. It consists of a set of condition places  $P_U = \{p_1, p_2, \dots, p_{m_1}\}$  and a set of conclusion places  $P_D = \{d_1, d_2, \dots, d_{m_2}\}$ , where  $m = m_1 + m_2$  denotes the total number of places in a FPN-R model.

$T = \{t_1, t_2, \dots, t_m\}$  denotes a set of transitions, corresponding to a set of reasoning rules.

$I = \{ I_{ij} \mid p_i \in P, t_j \in T \}$  is fuzzy input function, defined as  $P \times T$ . It can also be expressed as a  $m \times n$  dimensional matrix,  $I_{ij} \in [0,1]$ .

$O = \{ O_{ji} \mid p_i \in P, t_j \in T \}$  is fuzzy output function, defined as  $P \times T$ . It can also be expressed as a  $m \times n$  dimensional matrix,  $O_{ji} \in [0,1]$ .

$\tau: T \rightarrow (0,1]$  is a mapping which assigns a certainty value between 0 and 1 to each transition, denoting the firing threshold of this transition.

$\gamma: P \rightarrow (0,1]$  is a mapping to assign a certainty value to each place, denoting the legal threshold of this place.

$S_0: P \rightarrow [0,1]$  is the initial marking of FPN. It is also a mapping which assigns a certainty value to each place.

Figure 1 shows a FPN-R model example. Here, since  $\{S_0(p_1)=0.9\} > \{\gamma_1=0.2\}$  and  $\{S_0(p_2)=0.3\} > \{\gamma_2=0.2\}$  and  $\{S_0(p_1) \times I_{11} + S_0(p_2) \times I_{21} = 0.78\} > \{\tau_1 = 0.5\}$ ,  $t_1$  is enabled and fired to get  $S(p_3) = 0.78 \times O_{13} = 0.78 \times 0.9 = 0.7$ . On the contrary, because  $S_0(p_2) \times I_{22} = 0.3 < \{\tau_2 = 0.4\}$ ,  $t_2$  is not enabled. So  $S(p_4)$  remains to be 0.

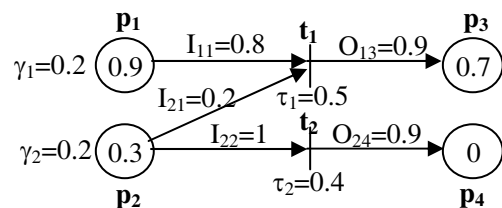

Figure 1 A model example of FPN-R

Two advantages of FPN-R can be drawn from this example: updating the input / output weight from integer value to real value can enhance the model power on describing uncertainty, and introducing the legal threshold to places prevent those low-possibility conditions from being calculated.

### 3.2 Modelling and Application Procedure of FPN-R

As shown in Figure 2, the modeling and application process of FPN-R could be performed in the following phases:

- Building model structure - After determining the rescheduling problem scope (disturbance factors and desired conclusion) and reasoning rules, model elements, P and T, as well as their relations should be defined in this phase;

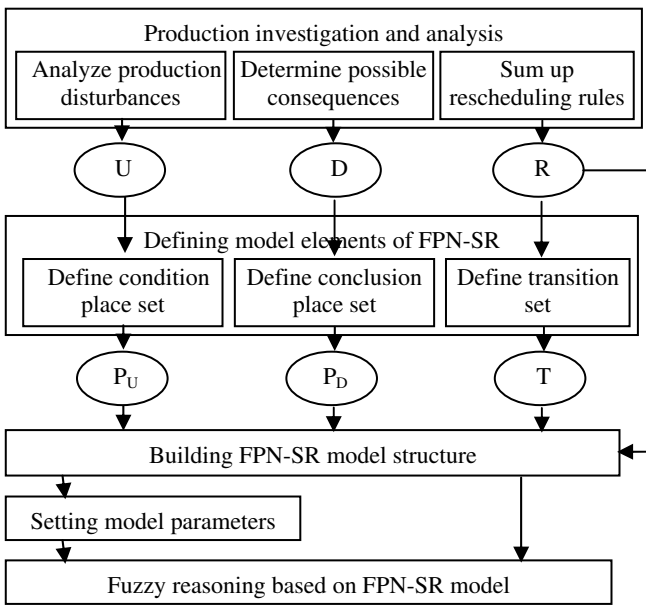

Figure 2 Model and application procedure of FPN-R

- Setting model parameters - All model parameters should be initialized in this phase, like  $S_0$  and  $\gamma$  of each place  $p_i$ ,  $i=1,2,\dots,m$  and  $\tau$  of each transition  $t_j$ ,  $j=1,2,\dots,n$ .
- Fuzzy reasoning based on model - Based on the model structure and parameters, a model based series of reasoning operations will be executed in this phase to support the rescheduling decision-making.

## 4. FUZZY REASONING FOR RESCHEDULING STRATEGY OF SEMICONDUCTOR PRODUCTION

### 4.1 FPN-R Model Parameter Initialization

**Initialization of  $S_0$**   $S_0(p_i)$  denotes the creditability of place  $p_i$  (If  $p_i \in P_D$ , then  $S_0(p_i)=0$ ). The initial vector of  $S_0(p_i)$  reflects the practical status of production environment, especially the disruptions being addressed.

**Initialization of  $\gamma$**   $\gamma$  lets the low-possibility conditions out of consideration. That is to say, when  $\{S_0(p_i) < \gamma(p_i)\} \wedge \{I_{ij} > 0\}$ ,  $t_j$  is not enabled and can not be fired. So, the role  $p_i$  plays in rescheduling reasoning is strongly dependent on the initialization of  $\gamma(p_i)$ .

**Initialization of  $\tau$**   $\tau$  gives lower firing threshold of an enabled transition, namely  $t_j$  can not be fired if  $\Sigma\{S_0(p_i) \times I_{ij}\} < \tau_j$ .

### 4.2 FPN-R Based Reasoning

The FPN-R based reasoning is carried out by matrix calculation. FPN-R can also be expressed in matrix format:

Model Input:  $I$  and  $O$  are  $m \times n$  dimensional matrixes.  $\gamma$  and  $S_0$  are  $n$  dimensional vectors.  $\tau$  is a  $n$  dimensional vector.

Model Output:  $P_D \subset P$  is a  $m_2$  dimensional vector,  $S_0(p_k)=0$ ,  $p_k \in P_D$ .

Firing Criterion: If and only if  $\forall p_i, \forall t_j$  and expression (2) is true, then  $t_j$  is enabled at marking  $S_k$ .

$$\{S_k(p_i) > \gamma(p_i)\} \wedge \{I_{ij} > 0\} \wedge \{\Sigma[S_k(p_i) \times I_{ij}] > \tau_j\} \quad (2)$$

Firing Rule: When  $t_j$  is enabled at  $S_k$  and fired, the subsequent marking  $S_{k+1}$  is:

$$S^{k+1}(p_i) = \begin{cases} \Sigma\{S_k(p_i) \times I_{ij}\} O_{jl}, & \text{when } O_{jl} > 0 \\ S_k, & \text{when } O_{jl} = 0 \end{cases} \quad (3)$$

Conclusion Synthesis Rule: When more than one transition firings result in the same conclusion (Their output places are the same, for example  $p_i$ ). The value  $S_{k+1}(p_i)$  should be unified, and usually with the maximum theorem as (4) (Jia et al., 2003).

$$S_{k+1} = S_k \oplus S^{k+1} \quad (4)$$

Here,  $C = A \oplus B \Leftrightarrow c_{ij} = \max(a_{ij}, b_{ij})$

FPN-SR based fuzzy reasoning procedure is to check transition(s) that meet (2) and fire it / them to get the successive markings through (3) and (4). Then repeat these two steps continually until  $S_{k+1} = S_k$ .

## 5. EXAMPLE OF RESCHEDULING DECISION FOR SEMICONDUCTOR PRODUCTION

Next an example will be given to show how to use FPN-R to model a rescheduling problem triggered by rush order arrival. And further fuzzy reasoning will also be illustrated.

### 5.1 Modelling the Rescheduling Problem

The FPN-R model of the rescheduling problem triggered by rush order arrival is shown as Figure 3.

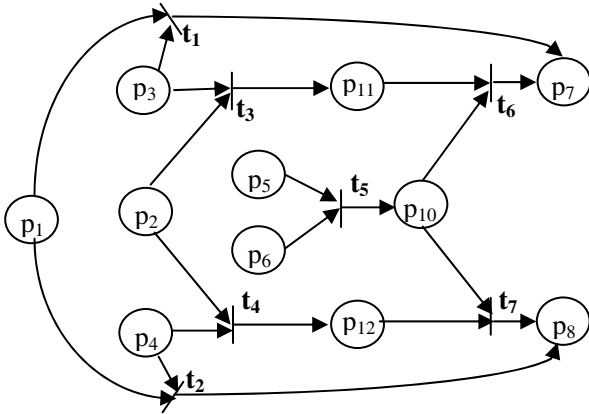

Figure 3 FPN-R model for rescheduling decision in response to rush order

$$P = \{p_1, p_2, p_3, p_4, p_5, p_6, p_7, p_8, p_{10}, p_{11}, p_{12}\}$$

$$= P_U \cup P_D$$

$P_U = \{p_1, p_2, p_3, p_4, p_5, p_6\} = \{\text{High urgency, Low urgency, High load, Low load, Far from next periodic rescheduling point, Incompact initial schedule}\}$

$P_D = \{p_7, p_8\} = \{\text{regeneration rescheduling, partial rescheduling}\}$

$$T = \{t_1, t_2, t_3, t_4, t_5, t_6, t_7\}$$

$$= \{\text{rule1, rule2, rule3, rule4, rule5, rule6, rule7}\}$$

$I = \{I_{ij}\}$ , there exists an arc from  $p_i$  to  $t_j$ .

$O = \{O_{ji}\}$ , there exists an arc from  $t_j$  to  $p_i$ .

### 5.2 Setting model parameters

To set the model parameters is not an easy task, and usually needs plenty of investigation and synthesis of both production circumstance and historical experiences. As an example, following is one parameter setting:

$$\gamma = \{0.3, 0.3, 0.2, 0.2, 0.4, 0.3, 0.2, 0.2, 0.2, 0, 0\}$$

$$\tau = \{0.6, 0.6, 0.4, 0.4, 0.3, 0.4, 0.4\}$$

$$S_0 = \{0.1, 0.9, 0.8, 0.2, 0.6, 0.8, 0, 0, 0, 0, 0\}$$

$$I/O = \begin{pmatrix} 0.5 & 0.5 & & & & & & & & & -1 \\ 0.5 & & 0.5 & & & & & & & & -1 \\ & 0.3 & 0.7 & & & & & & & & -1 \\ 0.3 & & 0.7 & & & & & & & & \\ & & & 0.4 & 0.6 & -1 & & & & & \\ & & & & 0.4 & 0.6 & -1 & & & & \\ & & & & & 0.4 & 0.6 & -1 & & & \end{pmatrix}$$

### 5.3 Fuzzy reasoning based rescheduling decision

Step one: under initial marking  $S_0$ ,  $t_3$ ,  $t_4$  and  $t_5$  are enabled according to firing criterion, equation (2). After these three transitions are fired, the subsequent marking  $S_1 = \{0.1, 0.9, 0.8, 0.2, 0.6, 0.8, 0.72, 0.83, 0.41, 0, 0\}$  could be reached according to equations (3) and (4).

Step one: under marking  $S_1$ ,  $t_6$  and  $t_7$  are enabled according to firing criterion, equation (2). After these transitions are

fired, the subsequent marking  $S_2 = \{0.1, 0.9, 0.8, 0.2, 0.6, 0.8, 0.72, 0.83, 0.41, 0.79, 0.53\}$  could be reached.

So, as shown by the reasoning conclusion, the creditability of making the decision based on regeneration rescheduling and partial rescheduling is 0.79 and 0.53 respectively.

If considering another circumstance when  $S_0 = \{0.1, 0.9, 0.8, 0.2, 0.2, 0.3, 0, 0, 0, 0, 0\}$ , it can be found that no conclusion could be drawn. That means no rescheduling ought to be triggered. And the reason might be it is quite close to the next periodical rescheduling point.

## 6. CONCLUSIONS

A new kind of fuzzy Petri nets based rescheduling model (FPN-R) for semiconductor production line has been proposed. It has three obvious advantages. Firstly it combines two aspects of the rescheduling strategy problem, namely start-up decision and method-choice decision into one model. Secondly it tries to set a formal model for the unstructured rescheduling problem so as to be calculated with matrix. Lastly, it introduces threshold to take the practical factors into consideration.

Then the application approach of the proposed FPN-R, including model structure building, model parameter setting and model based fuzzy reasoning, has been discussed and illustrated with an example of rush order triggered rescheduling problem.

Further studies could be carried on with optimization of the model parameters, other rescheduling triggering factors and the corresponding rescheduling problem, etc.

## ACKNOWLEDGMENT

The authors gratefully acknowledge the National Natural Science Foundation of China (No. 70531020), the National Basic Research Program of China (No. 2002CB312202) and the Program for New Century Excellent Talents (No. NCET-07-0622) for their research support and project sponsorship.

## REFERENCES

Abumaizar, R.J., et al. (1997) Rescheduling job shops under disruptions, *International Journal of Production Research*, **35**, 1997: 2065-2082.

Bierwirth, C., and C.M. Dirk (1999) Production scheduling and rescheduling with genetic algorithms, *Evolutionary Computation*, **V. 7, N. 1**, 1999, pages 1-17

Chen S.M, J.S. Ke, J.F. Chang (1990) Knowledge representation using fuzzy Petri nets, *IEEE Trans Knowledge and Data Engineering*, **V.2,N.3**, 1990, 311-319

Church, L.K., and R. Uzsoy (1992) Analysis of periodic and event-driven rescheduling policies in dynamic shops. *International Journal of Computer Integrated Manufacturing*, **5**, 1992, 153-163

Jia, L.X., J.Y. Xue, F. Ru (2003) Fuzzy Petri net based formalized reasoning algorithm with applications, *Journal of Xi'an Jiaotong University*, **Vol.37, No.12**, 2003: 1263-1266

- Li, H., Z. Li, L.X. Li, B. Hu (2000) A production rescheduling expert simulation system, *European Journal of Operational Research*, **124 (2000)**: 283-293
- Li, X., F. Lara-Rosano, (2000) Adaptive fuzzy Petri nets for dynamic knowledge representation and inference, *Expert Systems with Applications*, **19(2000)** 235-241
- Olumolade, M.O., and D.H. Norrie (1996) Reactive scheduling system for cellular manufacturing with failure-prone machines. *International Journal of Computer Integrated Manufacturing.*, **9, 2, 1996**: 131-14
- Qiao, F., L. Li, et al. (2007) Improved hybrid rescheduling strategy for semiconductor manufacturing, *Computer Integrated Manufacturing System*, **Vol.13, No.3, 2007**: 558-562
- Vieira, G.E., W.H. Jeffrey, et al. (2000) Predicting the performance of rescheduling strategies for parallel machine systems, *Journal of Manufacturing Systems*, **V. 19, N. 4, 2000**: 256-266
- Vieira, G.E., et al.(2002) Rescheduling Manufacturing Systems: A framework of Strategies, Policies, and Methods, *Journal of Scheduling*, **March 14, 2002**