

MODEL BRIDGE CONTROL -MULTI DEGREE OF FREEDOM DESIGN FOR HIGH ROBUSTNESS AND HIGH PERFORMANCES-

Keiji Watanabe and Rui Wang

Yamagata University
 Jonan-4-3-16, Yonezawa-shi, 992-8510 Japan
 kw@yz.yamagata-u.ac.jp

Abstract: This paper proposes a new concept of robust control – Model Bridge Control (MBC). The MBC is a multi-degree of freedom control based on the model bridge principle (MBP) that the gaps between objects and achievements are bridged by individual models. The key of MBC is the error compensation by the model which covers both gain and phase of the error. This breaks through the trade-off between the robust stability and performances, and yields high robustness and high performances simultaneously beyond the small gain theorem. A new robust stability criteria and systematic design method are presented.

1. INTRODUCTION

In control systems, there is the trade-off between the robust stability and the sensitivity. To manage the trade-off, weighting functions are introduced on the basis of the small gain theorem. They are integrated in a generalized plant. The controller is designed by H^∞ control (Doyle et al. 1989) or LMI such that the H^∞ norm of the generalized plant is less than 1. This approach, however, suffers from the following problems.

- (1) the resulting control system is conservative.
- (2) The trade-off is tight because the total norm of the gathered system is forced to be small.
- (3) The choice of the weighting function is complicated to get the solution.
- (4) Since performance assignment is indirect, there is a case that the response is not desirable even if the problem is solved
- (5) The controller, sometimes, have higher order exceed the plant and yields slow responses, because the design is prepared to treat the worst case.

In this paper, a new robust control is proposed for breakthrough of above problems. It is called as the model bridge control (MBC) and can yield high robustness and high performances simultaneously beyond the small gain theorem. The concept, the configuration of MBC and the new robust stability criteria are proposed. The numerical example shows usefulness of MBC.

2. WHAT IS MODEL BRIDGE CONTROL

Two definitions are proposed.

<Definition 1>: Model Bridge Principle (MBP)

The model bridge principle (MBP) is that gaps between objects and achievements are bridged by models respectively.

<Definition 2> Model Bridge Control(MBC)

The model bridge control (MBC) is a multi-degree of freedom control which bridges the gap between the model error and the robust stability, and the gaps between external signals and their responses by individual models on the basis of MBP.

The grasp of the concept, analysis, design and realization of MBC are achieved according to the flow shown in Fig.1, where the left hand is the objects and the right hand is the achievements, and they are bridged by blocks respectively.

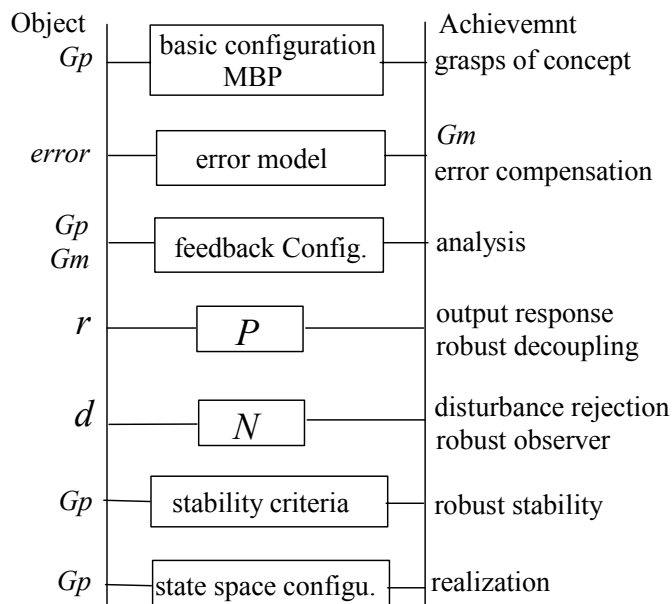

Fig.1 The flow of MBC

3. MODEL BRIDGE PARAMETRIZATION

First of all, consider the top of the flow, the grasps of the concept of MBC. The basic model bridge control system (MBCS) is given as the model bridge parametrization (MBPZ) shown in Fig.2.

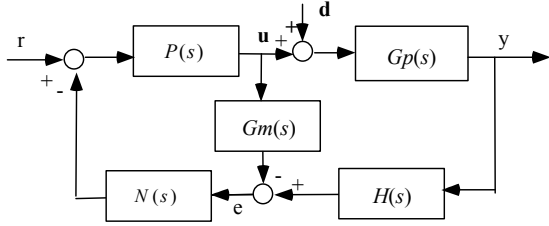

Fig.2 basic configuration of MBCS(MBPZ)

It is similar to the internal model control (Morari 1989), but differs from IMC in multi degree-of-freedom. According to MBP, $G_p(s) \in R^{m \times m}(s)$ is the control subject with perturbation. $G_m(s) \in R^{m \times m}(s)$ is the plant model compensated by feedforward model of the error for robust stability. It is assumed that $G_p(s)$ and $G_m(s)$ are invertible. $P(s) \in R^{m \times m}(s)$ is the reference controller for reference input r , which involves inverse model of the plant for good responses, $N(s) \in R^{m \times m}(s)$ is the disturbance compensator for d , which generates the inverse model of the plant for disturbance rejection. $H(s) \in R^{m \times m}(s)$ is the low-pass filter for noise reduction. In this paper, let $H(s) = 1$.

4. ERROR COMPENSATION

Second, consider the error compensation that is the key of MBC. In Fig.2, The controlled system $G_p(s)$ is given by

$$G_p(s) = \begin{bmatrix} (1 + \Delta_{11}(s))G_{11}(s) & \cdots & (1 + \Delta_{1m}(s))G_{1m}(s) \\ \vdots & & \vdots \\ (1 + \Delta_{m1}(s))G_{m1}(s) & \cdots & (1 + \Delta_{mm}(s))G_{mm}(s) \end{bmatrix} \quad (1)$$

where $G_{ij}(s)$ is the model and $1 + \Delta_{ij}(s)$ is the error. satisfying the following assumptions.

<Assumption 1>

the number of unstable poles of $(1 + \Delta_{ij}(s))G_{ij}(s)$ is equal to that of $G_{ij}(s)$.

<Assumption 2>

$$|1 + \Delta_{ij}(j\omega)| \leq k_{ij} \quad \forall \omega \geq 0 \quad (2)$$

<Assumption 3>

$$-\omega l_{ij} \leq \angle(1 + \Delta_{ij}(j\omega)) \leq 0 \quad \forall \omega \geq 0 \quad (3)$$

The assumption 2 is verified by

$$\frac{|1 + \Delta_{ij}(j\omega)G_{ij}(j\omega)|}{|G_{ij}(j\omega)|} \leq k_{ij}, \quad \forall \omega \geq 0 \quad (4)$$

In assumption 3, the left hand of (3) implies the phase of time delay l_{ij} . Thus, l_{ij} satisfying assumption 2 is easily estimated such that the step response of $G_{ij}(s)e^{-sl_{ij}}$ follows the response of the plant $(1 + \Delta_{ij}(s))G_{ij}(s)$ at raising part as

shown in Fig.3, where the real line is $(1 + \Delta_{ij}(s))G_{ij}(s)$, the dotted line is $G_{ij}(s)$ and the chain line is $G_{ij}(s)e^{-sl_{ij}}$

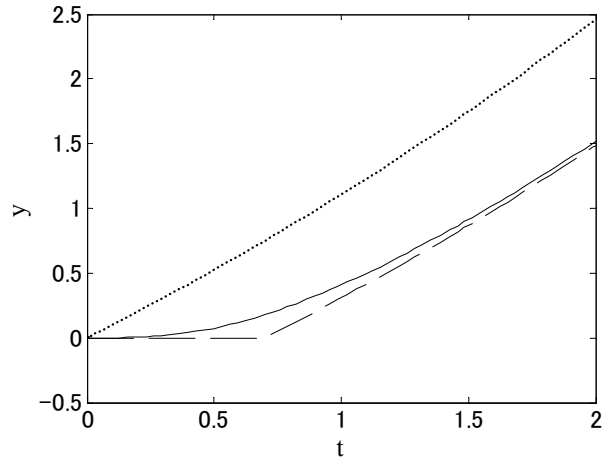

Fig.3 estimation of l_{ij}

From these assumptions, the error models for $1 + \Delta_{ij}(s)$ are given by

$$m_{ij}(s) = \frac{k_{ij}}{(1 + \frac{l_{ij}}{p}s)^p} \quad (5)$$

where $p=1$ or 2 from numerical experiences. If smaller error are required, then increase p .

The error compensated plant is represented by

$$G_m(s) = \begin{bmatrix} m_{11}(s)G_{11}(s) & \cdots & m_{1m}(s)G_{1m}(s) \\ \vdots & & \vdots \\ m_{m1}(s)G_{m1}(s) & \cdots & m_{mm}(s)G_{mm}(s) \end{bmatrix} \quad (6)$$

Let

$$G_p(s) = \delta(s)G_m(s) \quad (7)$$

where

$$\delta(s) = \begin{bmatrix} \delta_{11}(s) & \cdots & \delta_{1m}(s) \\ \vdots & & \vdots \\ \delta_{m1}(s) & \cdots & \delta_{mm}(s) \end{bmatrix} \quad (8)$$

If the error compensation is adequate, then

$$\delta_{ii}(s) \rightarrow 1 \text{ and } |\delta_{ij}(s)| \rightarrow 0 \quad (i \neq j) \quad (9)$$

The e depending on the model error in Fig.2 is reduced and increases the robust stability.

5. FEEDBACK CONFIGURATION OF MBC

In order to stabilize MBC for unstable plants or to analyze MBC, the basic MBCS is transformed to the feedback configuration shown in Fig.4, where

$$G_c(s) = [I - P(s)N(s)G_m(s)]^{-1}P(s) \quad (10)$$

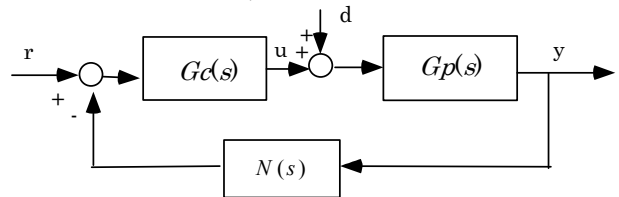

Fig.4 MBCS(the feedback configuration)

If the error compensation is perfect, then $G_p(s) = G_m(s)$ and the outputs y to reference r and disturbance d are given by

$$y(s) = G_m(s)P(s)r(s) \quad (11)$$

$$y(s) = [I - G_m(s)P(s)N(s)]G_m(s)d(s) \quad (12)$$

respectively. It should be noted that the response to the reference r can be adjusted linearly by $P(s)$ and disturbance rejection can be performed linearly by $N(s)$. The $P(s)$ and $N(s)$ are designed to make both (11) and (12) diagonal in order to reduce the interactions which affects the robustness under the following assumptions.

<Assumption 4> unstable zeroes of $G_m(s)$ are row zeroes.

<Assumption 5> $G_m(s)$ can be decoupled by state feedback.

Even if the original $G_m(s)$ does not satisfy the assumptions, the pre-compensation makes them satisfied (Asagi 2004, Wang 2006, Watanabe 2006).

6. DESIGN OF $P(s)$

Consider the observable block diagonal realization of $G_m(s)$ for (11) and (12) to be diagonal. Let the state space form of the i -throw of $G_m(s)$ be

$$\begin{bmatrix} m_{i1}(s)G_{i1}(s) & \cdots & m_{im}(s)G_{im}(s) \end{bmatrix} \quad (13)$$

$$= c_i(sI - A_i)^{-1}B_i$$

where (A_i, B_i) is controllable and (c_i, A_i) is observable. It is assumed that

$$G_m(s) = C(sI - A)^{-1}B = G_I(s)\bar{C}(sI - A)^{-1}B \quad (14)$$

where

$$A = \begin{bmatrix} A_1 & & 0 \\ & \ddots & \\ 0 & & A_m \end{bmatrix} \in R^{n \times n}, B = \begin{bmatrix} B_1 \\ \vdots \\ B_m \end{bmatrix} \in R^{n \times m} \quad (15)$$

$$C = \begin{bmatrix} C_1 \\ \vdots \\ C_m \end{bmatrix} = \begin{bmatrix} c_1 & & 0 \\ & \ddots & \\ 0 & & c_m \end{bmatrix} \in R^{m \times n} \quad (16)$$

$$\bar{C} = \begin{bmatrix} \bar{C}_1 \\ \vdots \\ \bar{C}_m \end{bmatrix} = \begin{bmatrix} \bar{c}_1 & & 0 \\ & \ddots & \\ 0 & & \bar{c}_m \end{bmatrix} \in R^{m \times n}$$

$$G_I(s) = \begin{bmatrix} G_{I1}(s) & & 0 \\ & \ddots & \\ 0 & & G_{Im}(s) \end{bmatrix} \quad (17)$$

and $G_{Ij}(s)$ are inner with unstable zeros of $G_m(s)$. Let

$$P(s) = [I + F(sI - A)^{-1}B]Q_a \quad (18)$$

where $A - BF$ is stable and Q_a is a free parameter. Substituting (14) and (18) into the left hand of (11) yields

$$y(s) = G_m(s)P(s)r(s) = C(sI - A + BF)^{-1}BQ_a r(s) \quad (19)$$

The transient response can be adjusted by F and the steady state one by Q_a . we design them to satisfy

$$y(s) = C(sI - A + BF)^{-1}BQ_a r(s) = \begin{bmatrix} G_{F1}(s)G_{I1}(s) & & 0 \\ & \ddots & \\ 0 & & G_{Fm}(s)G_{Im}(s) \end{bmatrix} r(s) \quad (20)$$

considering the internal stability, where

$$G_{iF}(s) = \frac{1}{(1 + \tau s)^2 (1 + \gamma \tau s)^{\nu_i - 2}} \quad (21) \quad \tau > 0,$$

$0 < \gamma < 1$ for robust stability explained later.

Such F and Q_a can be obtained by the decoupling method as follows.

Let

$$\bar{C}_i A^j B = 0, j = 0, 1, 2, \dots, \nu_i - 2 \quad (22)$$

$$\bar{C}_i A^{\nu_i - 1} B \neq 0$$

From the assumption,

$$\Phi = \begin{bmatrix} \bar{C}_1 A^{\nu_1 - 1} B \\ \vdots \\ \bar{C}_m A^{\nu_m - 1} B \end{bmatrix} \quad (23)$$

is non-singular. Let

$$p_i(s) = (1 + \tau s)^2 (1 + \gamma \tau s)^{\nu_i - 2} = \alpha_{i\nu_i} s^{\nu_i} + \dots + \alpha_{i1} s + 1$$

$$\Psi = \begin{bmatrix} \alpha_{1\nu_1} \bar{C}_1 A^{\nu_1} + \dots + \alpha_{11} \bar{C}_1 A + \bar{C}_1 \\ \vdots \\ \alpha_{m\nu_m} \bar{C}_m A^{\nu_m} + \dots + \alpha_{m1} \bar{C}_m A + \bar{C}_m \end{bmatrix}$$

$$\Omega = \text{diag}[\alpha_{1\nu_1} \quad \dots \quad \alpha_{m\nu_m}]$$

The F and Q_a satisfying (20) are given by

$$F = \Phi^{-1} \Omega^{-1} \Psi \quad (24)$$

$$Q_a = \Phi^{-1} \Omega^{-1} \quad (25)$$

For $G_p(s) \neq G_m(s)$, this implies from (7) and (20) that

$$G_p(s)P(s) = \delta(s) \begin{bmatrix} G_{F1}(s)G_{I1}(s) & & 0 \\ & \ddots & \\ 0 & & G_{Fm}(s)G_{Im}(s) \end{bmatrix} \quad (26)$$

If the error compensation are adequate, then (26) approaches to (20) and is said to be robust decoupling.

7. DESIGN OF $N(s)$

Next, consider the design of $N(s)$ and let

$$N(s) = Q_a^{-1}F(sI - A + KC)^{-1}K + Q_b \{I - C(sI - A + KC)^{-1}K\} \quad (27)$$

where $K \in R^{n \times m}$ and $Q_b \in R^{m \times m}$. It follows from (14), (18) and (27) that

$$y(s) = [I - G_m(s)P(s)N(s)]G_m(s)d(s) = \{I + C(sI - A + BF)^{-1}(K - BQ_a Q_b)\} C(sI - A + KC)^{-1}Bd(s) \quad (28)$$

The transient response can be adjusted by K and the steady state one by Q_b . In order to make H^∞ norm of $N(s)$ near one for robust stability (Izuta and Watanabe 2002), K is given by

$$K = YC^T \quad (29)$$

where $Y = Y^T \geq 0$ is the stabilizing solution of the Riccati equation

$$Y(A^T + \alpha I) + (A + \alpha I)Y - YC^T CY = 0 \quad (30)$$

for $\alpha \geq 0$ such that $A + \alpha I$ does not contain any eigenvalues at the imaginary axis. The transient responses to disturbances can be adjusted by $\alpha \geq 0$.

The parameter Q_b is given from (20) and (28) by

$$Q_b = I + C(-A + BF)^{-1}K \quad (31)$$

to yield zero steady state error to step disturbances.

It follows from the structure (15), (16), (24), (25) and (29) that $N(s)$ becomes

$$N(s) = \begin{bmatrix} N_1(s) & & 0 \\ & \ddots & \\ 0 & & N_m(s) \end{bmatrix} \quad (32)$$

8. STABILITY CRITERIA

With above $P(s)$ and $N(s)$, we consider robust stability for the case that $G_p(s) \neq G_m(s)$. Equations (11) and (12) become

$$y(s) = G_p(s)P(s)E_1^{-1}(s)r(s) \quad (33)$$

$$y(s) = (I - G_m(s)P(s)N(s))E_2^{-1}(s)G_m(s)d(s) \quad (34)$$

respectively, where

$$E_1(s) = I + N(s)(G_p(s) - G_m(s))P(s) \quad (35)$$

$$E_2(s) = I + (G_p(s) - G_m(s))P(s)N(s) \quad (36)$$

<Lemma 1> The necessary and sufficient condition for the system shown in Fig.4 to be stable is that the vector plot of $\det E_1(j\omega) = \det E_2(j\omega)$ does not circle the origin.

It follows from (26) and (32) that

$$E_2(s) = \left\{ I + \begin{bmatrix} \delta_{11}(s) - 1 & & \delta_{1m}(s) \\ & \ddots & \\ \delta_{m1}(s) & & \delta_{mm}(s) - 1 \end{bmatrix} \begin{bmatrix} G_{F1}(s)G_{I1}(s)N_1(s) & & 0 \\ & \ddots & \\ 0 & & G_{Fm}(s)G_{Im}(s)N_2(s) \end{bmatrix} \right\} \quad (38)$$

In order to check the stability of (38), we introduce the diagonal dominant matrix is defined as follows.

Consider

$$Z = \begin{bmatrix} z_{11} & \cdots & Z_{1m} \\ \vdots & & \\ Z_{m1} & \cdots & Z_{mm} \end{bmatrix} \in R^{m \times m}(s) \quad (39)$$

If

$$|z_{ii}| > \sum_{\substack{j=1 \\ j \neq i}}^m |z_{ij}| \quad (40)$$

for arbitrary $s \in C$ and all i , then Z is said to be the row dominant. If

$$|z_{ii}| > \sum_{\substack{j=1 \\ j \neq i}}^m |z_{ji}| \quad (41)$$

for arbitrary $s \in C$ and all i , then Z is said to be the column dominant. If Z is the row dominant or the column dominant, then Z is said to be diagonal dominant.

<Lemma 2> (Rosenbrock 1974) Consider that $Z(s)$ is diagonal dominant and Γ is the closed contour in the complex plane. Let $Z_{ii}(s)$ encircle the origin μ_i times and $\det Z(s)$ encircles the origin μ times, as s travels Γ once. Then, we have

$$\mu = \sum_{i=1}^m \mu_i \quad (42)$$

Equation(38), Lemma 1 and 2 yield the following lemma.

<Lemma 3> If the vector plot of

$$1 + \{\delta_{ii}(j\omega) - 1\}G_{Fi}(j\omega)G_{Ii}(j\omega)N_i(j\omega)$$

does not encircle the origin and

$$|1 + \{\delta_{ii}(j\omega) - 1\}G_{Fi}(j\omega)G_{Ii}(j\omega)N_i(j\omega)| > r_i$$

$$r_i = |G_{Fi}(j\omega)G_{Ii}(j\omega)N_i(j\omega)| \sum_{\substack{j=1 \\ i \neq j}}^m |\delta_{ji}(j\omega)| \quad (43)$$

is met, then the system shown in Fig.2 is stable.

The lemma 3 is transformed to the illustrative one.

<Lemma 4> Consider Fig.5,

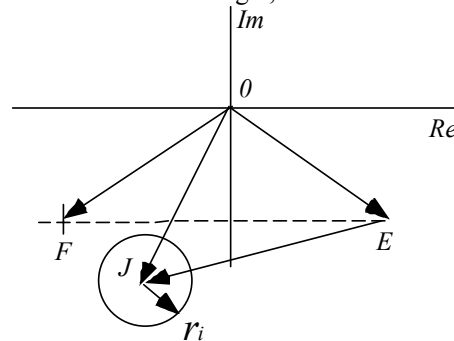

Fig. 5 Stability condition 1

where

$$0E = G_{Fi}(j\omega)G_{Ii}(j\omega)N_i(j\omega) \quad (44)$$

$$0F = G_{Fi}(j\omega)G_{Ii}(j\omega)N_i(j\omega) - 1 \quad (45)$$

$$0J = \delta(j\omega)G_{Fi}(j\omega)G_{Ii}(j\omega)N_i(j\omega) \quad (46)$$

If the circle with center J and radius r_i does not encircle the point F , then the system is stable.

We introduce the following assumptions

<Assumption 6>

Diagonal elements of $\delta(s)$ satisfy

$$|W_{lii}(j\omega)| \leq |\delta_{ii}(j\omega)| \leq |W_{xii}(j\omega)| \leq 1, \quad \forall \omega \geq 0 \quad (47)$$

where $W_{xii}(s), W_{lii}(s) \in R(s)$ and

$$-\omega L_{ii} \leq \angle \delta_{ii}(j\omega) \leq 0 \quad \forall \omega \geq 0 \quad (48)$$

<Assumption 7>

Non-diagonal elements satisfy

$$|\delta_{ij}(j\omega)| \leq |W_{Xij}(j\omega)| \leq 1, \quad \forall \omega \geq 0 \quad (49)$$

where $W_{Xij}(s) \in R(s)$.

These assumptions can be confirmed in the similar manner of assumptions 1~3. From these assumptions, the point J exists in the area ABCD shown in Fig.6, where

$$0A = |W_{Xii}(j\omega)| G_{Fi}(j\omega) G_{Fi}(j\omega) N_i(j\omega) \quad (50)$$

$$0B = |W_{Xii}(j\omega)| e^{-j\omega L_{ii}} G_{Fi}(j\omega) G_{Fi}(j\omega) N_i(j\omega) \quad (51)$$

$$0C = |W_{Lii}(j\omega)| e^{-j\omega L_{ii}} G_{Fi}(j\omega) G_{Fi}(j\omega) N_i(j\omega) \quad (52)$$

$$0D = |W_{Lii}(j\omega)| G_{Fi}(j\omega) G_{Fi}(j\omega) N_i(j\omega) \quad (53)$$

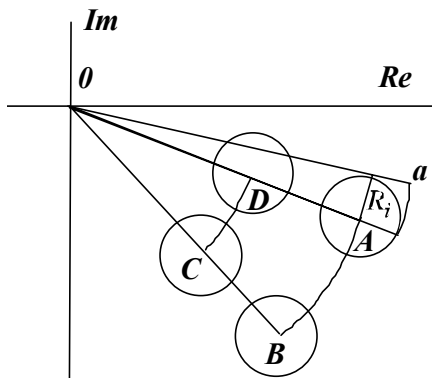

Fig.6 Area of J

Let

$$R_i = |G_{Fi}(j\omega) N_i(j\omega)| \sum_{\substack{j=1 \\ i \neq j}}^m |W_{Xji}(j\omega)| \quad (54)$$

The area which covers the circle with radius R_i and center A, B, C, D in Fig.6 is shown as abcd in Fig.7,

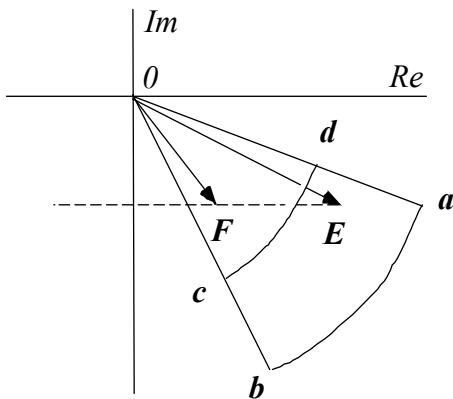

Fig.7 Stability condition 2

where

$$0a = (|0A| + R_i) e^{j \tan^{-1} \frac{R_i}{|0A|}} \quad (55)$$

$$0b = (|0B| + R_i) e^{-j(\tan^{-1} \frac{R_i}{|0A|} + \omega L_{ii})} \quad (56)$$

$$0c = (|0C| - R_i) e^{-j(\tan^{-1} \frac{R_i}{|0C|} + \omega L_{ii})} \quad (57)$$

$$0d = (|0D| - R_i) e^{j \tan^{-1} \frac{R_i}{|0D|}} \quad (58)$$

Since the circle in Fig.5 stays in the area abcd in Fig.7, lemma 4 yields

<Theorem 1> If the area abcd does not encircle F, then the system is robustly stable for arbitrary model error satisfying assumptions 6 and 7.

It follows from (9) that the error compensation makes the area abcd shrunk small and near E. Furthermore, Equation (21) implies that θF turns clockwise and half, and maintains near point (-1,0). These increase robust stability and allow time constant τ in (21) to be small. Thus, the high robust stability and high performance can be obtained simultaneously.

9. STATE SPACE MODEL OF MBC

For realization of MBC, derive the state space configuration of MBCS. The $G_c(s)$ in Fig.4 is represented by

$$G_C(s) = \{1 - P(s)N(s)G_m(s)\}^{-1} P(s) = [1 + f(sI - A + kc)^{-1} b - Q_a Q_b c(sI - A + kc)^{-1} b]^{-1} Q_a \quad (59)$$

Substituting (59) into

$$u(s) = \{1 - P(s)N(s)G_m(s)\}^{-1} P(s) \{r(s) - N(s)y(s)\}$$

yields

$$u(s) = -fz(s) + Q_a[r(s) - Q_b(s)\{y(s) - cz(s)\}] \quad (60)$$

$$z(s) = (sI - A + kc)^{-1} \{bu(s) + ky(s)\} \quad (61)$$

The state space configuration of Fig.4 is denoted in Fig.8.

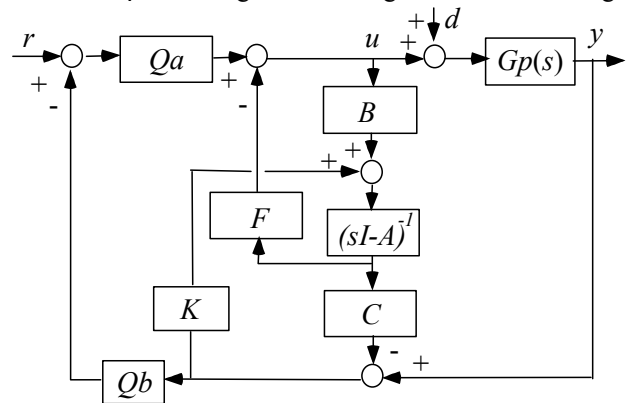

Fig.8 the state space model of MBC

(Remark 1) The realization (15) and (16) of $G_m(s)$ is observable, but the controllability is not guaranteed. There is a case that (61) is uncontrollable by u. It does not become problems, because (61) is stabilized by K and the control system is internally stable. Equation (61) is said to be a robust observer.

(Remark 2) The MBC has higher degree of freedom by 1 than Youla parametrization (Youla 1976).

10. NUMERICAL EXAMPLE

Finally, a numerical example is presented. Consider the unstable system with errors

$$G_p(s) = \begin{bmatrix} \frac{1}{(1+0.2s)^3} \frac{1}{(s-1)} & \frac{1}{(1+0.2s)^2} \frac{1}{(s+3)} \\ \frac{1}{(1+0.25s)^2} \frac{1}{(s-1)} & \frac{1}{(1+0.1s)^2} \frac{2}{(s+4)} \end{bmatrix} \quad (62)$$

and its model

$$G(s) = \begin{bmatrix} \frac{1}{(s-1)} & \frac{1}{(s+3)} \\ \frac{1}{(s-1)} & \frac{2}{(s+4)} \end{bmatrix} \quad (63)$$

In H^∞ control, model error $I + \Delta(s)$ is defined as

$$G_p(s) = (I + \Delta(s))G(s) \quad (64)$$

This yields

$$\Delta(s) = G_p(s)G^{-1}(s) - I \quad (65)$$

The weighting function satisfying

$$\sigma_{\max}[\Delta(j\omega)] < |W_T(j\omega)|, \quad \omega \geq 0 \quad (66)$$

is given by

$$W_T(s) = \frac{1+10s}{2.5} \quad (67)$$

The weighting function to the sensitivity is chosen by

$$W_s(s) = \frac{k_d}{s+0.001} \quad (68)$$

H^∞ control problem can not be solved for even small k_d such that $k_d = 0.001$.

On the other hand, model bridge control can give the solution easily by using error compensators

$$m_{11}(s) = \frac{1}{1+0.6s}, \quad m_{12}(s) = \frac{1}{1+0.4s} \\ m_{21}(s) = \frac{1}{1+0.5s}, \quad m_{22}(s) = \frac{1}{1+0.2s} \quad (69)$$

For the error compensated plant with (69), $P(s)$ and $N(s)$ are designed according to above sections. The responses to step reference inputs $r_1 = 1/s$ and $r_2 = 0.6/s$, and disturbances with amplitude 0.2 at $t = 15$ are shown in Fig.9 for $\tau = 1$ and $\alpha = 0$.

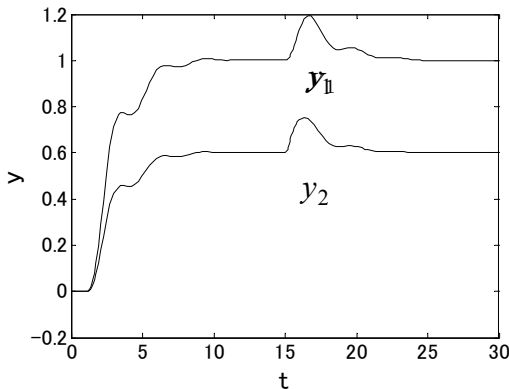

Fig.9 Responses

11. CONCLUSIONS

This paper proposed a new robust control, Model Bridge Control. The feature of MBC is to yield high robustness and high performances simultaneously under large model error beyond the small gain theorem. The key is multi-degree of freedom involving error compensation. It breaks through the trade-off which conventional robust control suffers from. The MBC can be designed easily from robust decoupling and robust observer for even cases where H^∞ control does not have a solution. Future works are to add various model bridges for various control purposes.

REFERENCES

Doyle, J.C., Glover K., Khargonekar P.P., and Francis B.A. (1989) IEEE Trans. AC, 34-8, 831-847.
 Morari M and Zafiriou E. (1989) Robust Process Control, Prentice-Hall.
 Rosenbrock H.H. (1974) Computer-Aided Control System Design, Academic Press
 Youla D.J., Jabr H.A. and Bongiorno J.J. (1976) IEEE Trans AC, 21-3, 319-338.
 Izuta G. and Watanabe K. (2002), Systems and Control Letters, 47, 375-382.
 Asagi Y., Watanabe K., Muramatsu E. Izuta G. and Ariga Y. (2004) IFAC LSS, 771-776.
 Wang R., Watanabe K. and et al (2006), Trans. SICE, 42, 2, 147-155
 Watanabe K. Wang R. and et al (2006) 17th MTNS, 2295-2299