

# A HAPTIC EXCAVATOR SYSTEM WITH ACTIVE MASSES UNDER SLIDING MODE PD FORCE/FORCE-POSITION CONTROL <sup>1</sup>

H.I.Torres-Rodríguez, V.Parra-Vega, F.J.Ruiz-Sánchez

*Mechatronics Division, CINVESTAV - IPN  
AP 14-740, México, D.F., 07300 México*

Abstract: We present a haptic interface-based excavator training system. This system is based on the full nonlinear excavator dynamic model which mimics an industrial excavator, and six degrees of freedom haptic interface. The interface is characterized of been conformed by two controlled prismatic joints that compensate the gravitational effects leaving the full power of the actuators to kinesthetic sensations transmission. The control of gravity compensation is based in the gravitational force vector of the dynamic model. On the other hand the excavator control is carry out through a robust, model free second order sliding mode force-position controller. We present and discuss simulation results of the whole excavator training system. *Copyright @ 2005 IFAC*

Keywords: Haptic Interface, Robotics, Sliding Modes, Force control

## 1. INTRODUCTION

Excavators are heavy duty hydraulic machines used in agricultural, mining and construction industry whose main functions are digging, ground leveling and material transport operations. These machines are driven by qualified operators who move joysticks and pedals in an organized manner to reach a desired performance. The sequences of movements are very complex and the fact that these joysticks and pedals are not an intuitive man-machine interface, MMI, expose the human operator to fatigue, reducing the ability to maneuver properly the excavator, provoking mechanical stress in the machine and increasing the risk of an accident. These problems are more evident in the training process. Thus, topics as simplification of the digging task and the reduction of the harm risks during the training period, are interesting for researchers however, until now, their attention

has been focused on automating different aspects of the excavator process, as for example (Tafazoli, 1999), (Simon P. DiMaio, 1998), (Stentz, 1998) which focused mainly on simplified modeling and control schemes, while (Koivo A.J, 1996) presented the full nonlinear model (neglecting the inertia of the heavy actuators). Instead of this, we are concerned not only in the control aspect of the excavator but in creating a new MMI, more intuitive and easy to use, based on a Mechatronics approach, that could be able to recreate the real dynamics of the system in a virtual environment furnishing the operator with more sensorial information.

We conjecture that one way to improve the excavation process is through a haptic interface, which makes possible to improve significantly the interaction between the user and a system through kinesthetic coupling in bidirectional way, therefore we focus on the full modeling and advanced control schemes of a novel haptic excavator, composed of a haptic interface as MMI, and an exca-

---

<sup>1</sup> Partially supported by CONACYT project 39727-Y.  
Email: (vicente,htorres,fruiz)@cinvestav.mx

vator to achieve kinesthetic coupling under transparency.

In this paper we present the advances in the construction of a haptic interface-based excavator training system. We present the dynamical model of the excavator calculated considering the mechanical effects of the hydraulic actuators. This model will be employed to reproduce with high fidelity the free and constraint motion of the excavator in a virtual environment. To control the virtual digging task we present and modeling a six degree of freedom haptic interface, where two degrees of freedom are used to compensate the gravitational effects. The coupling between the virtual excavator and the haptic interface is accomplish through a non linear PID controllers. We present and discuss simulation results.

## 2. EXCAVATOR MODEL

### 2.1 Cinematical Model

We employed the Denavit-Hartenberg procedure to calculate the direct cinematic of the links and to understand and the complexity and dependence of the movement of the actuators on the movement of the links. We used the excavator model showed in figure(1), due we are interested in digging operation. In this particular case, the excavator parameters are showed in the table 1, where the  $\theta_i$  are the rotational joint angles and  $d_i$ ,  $a_i$  are constant lengths.

$i$	1	2	3	4
$\alpha$	0	$\frac{\pi}{2}$	0	0
$\theta$	$\theta_1$	$\theta_2$	$\theta_3$	$\theta_4$
$a$	0	$a_2$	$a_3$	$a_4$
$d$	$d_1$	0	0	0

Table 1. Link parameters of the excavator.

The cinematical model, also is used to calculate linear an angular velocities of the excavator. These velocities will be used to obtain the dynamical model based in the Euler-Lagrange formulation. (Stai, 1963).

### 2.2 Dynamical Model

We obtained the dynamic model of the excavator to create a virtual simulator trying to reproduce with fidelity the behaviour of the excavator. For this reason we consider the dynamic of the links and the contribution of the forces of the mechanic parts of the telescopic actuators. To obtain this model, we employ the Euler-Lagrange formulation considering the angles of the links as the generalized coordinates of the system. Due the energy

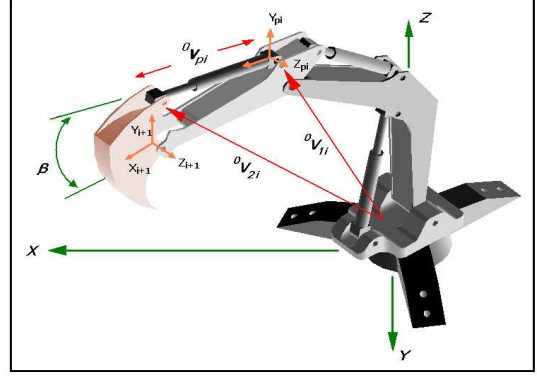

Fig. 1. Model of the proposed excavator.

present the additive property, the lagrangian of the excavator can be separated in two elements

$$L = Le + Lp. \quad (1)$$

where  $Le$  is the Lagrangian of the links and  $Lp$  is the Lagrangian of the actuators. Even more, using the linearity property of the derivative operator, the equation (1) can be wrote

$$\left[ \frac{d}{dt} \left( \frac{\partial \mathcal{L}_e}{\partial \dot{q}} \right) + \frac{\partial \mathcal{L}_e}{\partial q} \right] + D_p = Q \quad (2)$$

$$\left[ \frac{d}{dt} \left( \frac{\partial \mathcal{L}_p}{\partial \dot{q}} \right) + \frac{\partial \mathcal{L}_p}{\partial q} \right] = D_p \quad (3)$$

therefore the dynamic model of the system can be calculated by parts. The first part (the dynamic model of links) was computed using the procedure exposed in (Stai, 1963). On the other hand, to obtain the dynamic model of the actuators, was necessary to obtain the value of the angle  $\beta$  between the axial axis of the piston and the normal vector that links the joint of the link  $i$  and the link  $i + 1$  figure(2). To obtain  $\beta$  we need to calculate the vector  ${}^0V_{pi}$  figure(1), which is function of the lengths  $x_{i+1}$ ,  $y_{i+1}$ ,  $x_i$ ,  $y_i$  figure(2) and the transformation matrices  ${}^0A_{i+1}$ ,  ${}^0A_i$

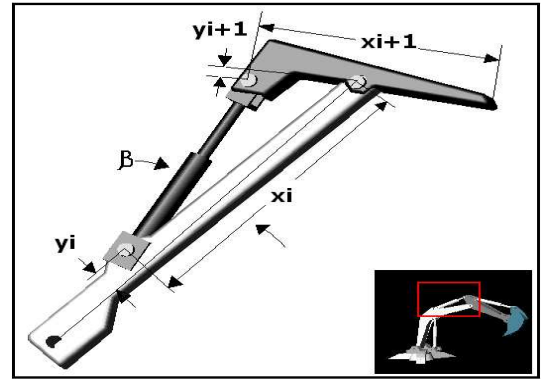

Fig. 2. Parameters of the links.

$${}^0V_{pi} = {}^0A_{i+1}^{i+1}V_{2i} - {}^0A_i^iV_{1i} \quad (4)$$

where the vectors  ${}^{i+1}V_{2i}$ ,  ${}^iV_{1i}$  are defined as

$${}^{i+1}V_{2i} = \begin{bmatrix} x_{i+1} \\ y_{i+1} \\ 0 \\ 1 \end{bmatrix}, {}^iV_{1i} = \begin{bmatrix} x_i \\ y_i \\ 0 \\ 1 \end{bmatrix}, \quad (5)$$

Using a coordinate change it can be obtained the vector  ${}^0V_p$  with reference to frame  $i$

$${}^iV_p = \begin{bmatrix} V_{pxi} \\ V_{pyi} \\ V_{pzi} \end{bmatrix} = {}^iR_0^0V_p = {}^iR_0 \begin{bmatrix} V_{px} \\ V_{py} \\ V_{pz} \end{bmatrix}. \quad (6)$$

The value of  $\beta$  is

$$\beta = \text{atan}\left(\frac{V_{pyi}}{V_{pxi}}\right). \quad (7)$$

Where  $\text{atan}$  is the tangent arc function, and  $V_{pxi}$  and  $V_{pyi}$  are the position coordinates  $(x, y)$  of the distal element of the actuator (the sliding element of the actuator), referenced to frame  $i$ .

Employing a new reference coordinate frame, located in the proximal extreme of the actuator joint, is possible to establish a similar procedure to Denavit-Hartenberg, in which the transformation matrix  ${}^iA_{pi}$  relates the position of the reference frame of the link  $i$  and the reference frame of the actuator  $i$ , which is defined

$${}^iA_{ip} = T(X, x_i)T(Y, y_i)T(Z, \beta). \quad (8)$$

where  $T(X, x_i)$  is a displacement matrix along the  $X$  axis of the link  $i$ ,  $T(Y, y_i)$  is a displacement matrix along the  $Y$  axis of the same link, and the matrix  $T(Z, \beta)$  represents a rotation in direction of the  $Z$  axis a  $\beta$  value. Using this transformation matrix the center of mass position  ${}^iP_{cpi}$  of the actuator referenced to inertial frame is

$${}^0P_{cpi} = {}^0A_i^iA_{pi}^iP_{cpi}. \quad (9)$$

Once we obtain the equation that describes the movement of the center of mass of the actuator, the actuators jacobian matrices can be calculated using the same methodology used to compute the dynamic model of the links (Stai, 1963).

In this way, the Euler-Lagrange equation of the excavator can be wrote as

$$\sum_{j=1}^n (\lambda) \ddot{q} + \beta + \alpha = Q \quad (10)$$

$$\alpha = \sum_{j=1}^n \sum_{k=1}^n \left[ \frac{\partial(\lambda)}{\partial q_k} - \frac{1}{2} \frac{\partial(\lambda)}{\partial q_i} \right] \ddot{q}_k \ddot{q}_j \quad (11)$$

$$\beta = \sum_{j=1}^n m_{ej} g^T J_{vj}^i + m_{pj} g^T J_{pvj}^i \quad (12)$$

where  $M_{eij}$ ,  $M_{pij}$  are the inertia matrix of the links and inertia matrix of the actuators respectively, and  $Q$  has the form

$$Q = W f_a + B_e \dot{q}. \quad (13)$$

and  $W$  is the relation matrix between the force of the actuators  $f_a$  and the control torques,  $B_e$  is a diagonal matrix representing the links viscous damping.

In this paper we consider as first approximation of digging process the soil as a rigid surface, under this consideration a constrained model, arises as follows.

$$M_e \ddot{q} + C_e \dot{q} + G_e + B_e \dot{q} = \tau_e + J_\varphi^T \lambda \quad (14)$$

$$\varphi(q) = 0. \quad (15)$$

where  $\varphi(q)$  define the rigid surface and  $J_\varphi^T$  is the orthogonal unit vector to this surface and  $\lambda$  is the magnitude of the contact force.

The same procedure presented to obtain the dynamic model of the excavator in free motion, was employed to obtain the dynamic model of the haptic interface, which also was calculated employing the Euler-Lagrange formulation.

### 3. HAPTIC INTERFACE MODEL

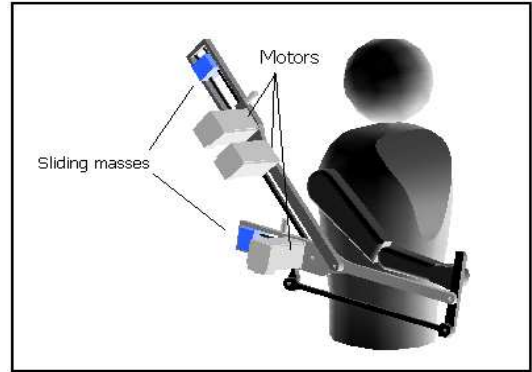

Fig. 3. Model of the proposed haptic interface.

To carry out a good mechanic design to the haptic interface, we obtain the dynamic model due we design supported on simulation results considering the behaviour of the system in a recursive form.

Similarly to the excavator, the haptic interface has four degrees of freedom, to be able to map 1 : 1 generalized coordinates. However, because we are including two sliding masses to compensate more effectively for gravitational torques, we proposed a six degrees of freedom mechanical device fully actuated by electric motors, see Figure (3). The Denavit-Hartenberg links parameters values are

showed in the table 2, where  $d_i, l_i, x_{m_i}$  are constant lengths.

$i$	1	2	3	4	$m1$	$m2$
$\alpha$	$\pi/2$	0	0	0	0	0
$\theta$	$\theta_1$	$\theta_2$	$\theta_3$	$\theta_4$	0	0
$a$	0	$l_2$	$l_3$	$l_4$	$x_{m1}$	$x_{m2}$
$d$	$-d_1$	$-d_2$	$d_3$	$-d_4$	0	0

Table 2. Link parameters of the haptic interface.

Using the same procedure used to calculate the excavator dynamic model, to calculate the haptic interface dynamic model is necessary solve de differential equation

$$\frac{d}{dt} \left( \frac{\partial L_{ih}}{\partial \dot{q}_{ih}} \right) + \frac{\partial L_{ih}}{\partial q_{ih}} = \tau. \quad (16)$$

where  $L_{ih}$  is the haptic interface Lagrangian and  $q_{ih}$  is the generalized variables vector, which in this case is formed by the variables  $\theta_i$ , and  $\tau$  is the external force vector (Stai, 1963). In this case, the dynamic model the haptic interface model is

$$\frac{d}{dt} \left( \frac{\partial(\delta)}{\partial \dot{q}_{ih}} \right) + \frac{\partial(\delta)}{\partial q_{ih}} = \tau. \quad (17)$$

$$\delta = L_l + L_m + L_{et} \quad (18)$$

where  $L_l$  is the links Lagrangian,  $L_m$  is the masses Lagrangian and  $L_{et}$  is the transmission elements Lagrangian. The general dynamic model is

$$M_h \dot{q} + C_h \dot{q} + G_h + B_h \dot{q} = \tau_h + \tau_o \quad (19)$$

where  $\tau_o$  stands for the operator input torque, since the operator is always grasping the handle of the haptic interface to control the system.

## 4. THE CONTROL SYSTEM

In this section we present the control algorithms for the excavator and haptic interface, which do not depend of the dynamic of the systems, due the complexity of the models. We consider second order sliding mode schemes for free (Parra, 2002), and constrained motion (Parra, 1996), (V. Parra-Vega and Akella, 2003), to guarantee local exponential tracking without using the model. These approaches are suitable for this tasks since they provide fast simultaneous trajectory tracking of position and force trajectories, even in the case of uncertainty on the dynamic model and its parameters.

### 4.1 Excavator Control System

*4.1.1. free motion:* In free motion,  $\tau_r = W f_a$  is a position control, where the desired trajectories of the excavator  $q_{dr}$  are

$$q_{dr} = \Omega_p q_h \quad (20)$$

where  $\Omega_p$  is a linear map between the haptic interface coordinates and the excavator coordinates.

Let consider

$$\tau_e = -K_d \left[ \{ (\Delta \dot{q}_e + \sigma \Delta q_e) - S_{pd}^e \} + \eta_1 \int_{t_0}^t \text{sgn} \{ (\Delta \dot{q}_e + \sigma \Delta q_e) - S_{pd}^e \} \right] \quad (21)$$

for  $\sigma > 0$ ,  $K_d = K_d^T \in R^{n \times n}$ , and  $S_{pd}^e = (\Delta \dot{q}_e + \sigma \Delta q_e)(t_0) e^{-\alpha_e(t-t_0)}$ , for  $\Delta q_e = q_e - q_{de}$ . This smooth controller guarantees local exponential tracking, without using the model (V. Parra-Vega and Akella, 2003).

*4.1.2. constrained motion:* In constrained motion, a force position controlled is necessary where the desired coordinates are

$$q_{dr} = \Omega_p q_h, \lambda_{dr} = \Omega_f \lambda_h \quad (22)$$

where  $\Omega_f$  is a linear map between the haptic interface force coordinates and the excavator force coordinates.

Let consider

$$\tau_e = -K_d Q \left[ \{ (\Delta \dot{q}_e + \sigma \Delta q_e) - S_{pd}^e \} + \eta_1 \int_{t_0}^t \text{sgn} \{ (\Delta \dot{q}_e + \sigma \Delta q_e) - S_{pd}^e \} \right] - \beta K_d J_{\varphi_+}^T [-\lambda_{dh} + \eta_h \Delta F_e] - \gamma_{2e} K_d J_{\varphi_+}^T * \left[ \tanh(\mu S^e) + \eta_h \int \text{sgn}(S^e) \right] \quad (23)$$

where  $\Delta F_e = \int_{t_0}^t (\lambda_e - \lambda_{de})$ ,  $\mu_e > 0$ ,  $\eta_e > 0$ ,  $\gamma_{2e} > 0$ , and  $S^e = \Delta F_e - \Delta F_e(t_0) e^{-\eta_e(t-t_0)}$ . Notice that  $J_{\varphi_+}^T$  is the normalized gradient of  $\varphi_e(q_e)$ , and  $Q$  its orthogonal complement.

### 4.2 Haptic Interface Control System

*4.2.1. free motion:* In free motion input signal is the torque of the operator  $\tau_o$  and the control of the sliding masses. This control compensates the gravitational effects varying the positions of the sliding masses computing the gradient of the haptic interface potential energy which is function of these positions ( $x_2$  and  $x_3$ )  $\nabla U(q) = \left[ \frac{\partial U(q)}{\partial q_1}; \frac{\partial U(q)}{\partial q_n} \right]$  then, the partial derivative with respect to links 2 and 3 must be zero to null the gravitational torques

$$\left[ \frac{\partial U(q)}{\partial q_2}, \frac{\partial U(q)}{\partial q_3} \right] = [0, 0] \quad (24)$$

finally, solving for  $x_2$  and  $x_3$ , we can obtain the desired position of the mass 2 and 3 for a position PID controller that nullifies the gravitational torques  $g(q) = 0$ . Notice that this controller is always turned on and produce a floating free haptic interface.

*4.2.2. constrained motion:* In constrained motion,  $\tau_h$  is formed by the sliding masses control and a new control that must be designed to reproduce a virtual constraint

$$\varphi_h = \Omega_{fh} q_r = 0 \quad (25)$$

where  $\Omega_{fh}$  is a linear map between the haptic interface force coordinates and the excavator force coordinates. This control must generate force to operator

$$\tau_h = J_{\varphi_h}^T \lambda_o \quad (26)$$

therefore the dynamic equation is as follow

$$M_h(q)\ddot{q} + C_h\dot{q} + G_h + B_h\dot{q} = J_{\varphi_h}^T \lambda_o + \tau_o \quad (27)$$

$$\varphi(q_h) = 0. \quad (28)$$

Let consider

$$\tau_e = -K_d Q \dot{q} - \beta K_d J_{\varphi_+}^T [-\lambda_{dh} + \eta_h \Delta F_h] - \gamma_{2h} K_d J_{\varphi_+}^T \left[ \tanh(\mu S_{qF}^h) + \eta_h \int \text{sgn}(S_{qF}^h) \right] \quad (29)$$

where  $\Delta F_h = \int_{t_0}^t (\lambda_o - \lambda_{do})$ ,  $\mu_h > 0$ ,  $\eta_h > 0$ ,  $\gamma_{2h} > 0$ , and  $S_{qF}^h = \Delta F_h - \Delta F_h(t_0)e^{-(t-t_0)}$ . Notice that under this control, the servosystem exerts a force  $J_{\varphi_+}^T \lambda_e$  to the hand of the human operator, and there is not any control over the position.

Some simulation results of the excavator and haptic interface performance under some of the control algorithms exposed in this section will be presented and discussed in the next section.

## 5. SIMULATIONS RESULTS

In this section we present simulation results which describe the behaviour of the excavator and the haptic interface separately, in this moment we are working in the total integration of the system, in fact we are considering employ a dynamic model to simulate the response of the human.

The results of simulation of the haptic interface are presented in the figure(4) and figure(5). We present two simulation results implementing a tracking control in free motion. In the first simulation figure(4) we present a result employing a PD control to maintain a predefined position of the

masses. It can be observed the constant value of the torque when the haptic interface reach the final position. In the second simulation figure (5) we used the balance control with the sliding masses. Employing this control the value of the control torques are reduced due the system is balanced and when the system reach the final position, the control torques of links 2 and 3 are reduced to zero.

In the simulation of the excavator figures(6,7,8, 9,10) was considered the transition of of movement from free motion to constrained motion. In this simulation results it can be observed the increment of magnitude of contact force and its subsequent stabilization and tracking of a sine function. In the other hand the tracking position errors are different to zero before the excavator touch the soil due the holonomic constraint imposed by the rigid surface.

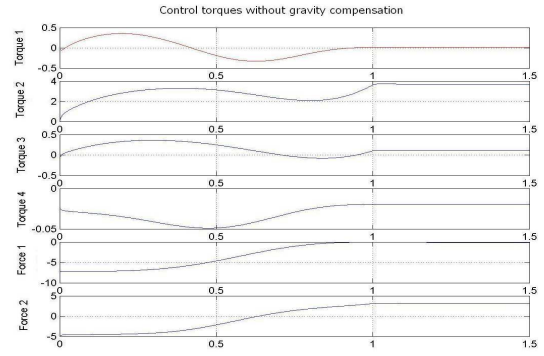

Fig. 4. Controllers without active mass control.

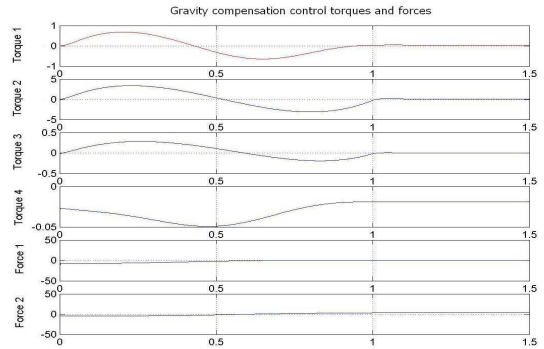

Fig. 5. Controllers with active mass control.

## 6. CONCLUSIONS

A new haptic interface, a complex dynamical model of an excavator which considers the dynamic of the telescopic actuators and an advanced force-position and force controllers have been proposed. Simulation data suggest that the controlled motion of sliding masses are critical to achieve haptic transparency. On the other hand the control system of the excavator produce a satisfactory

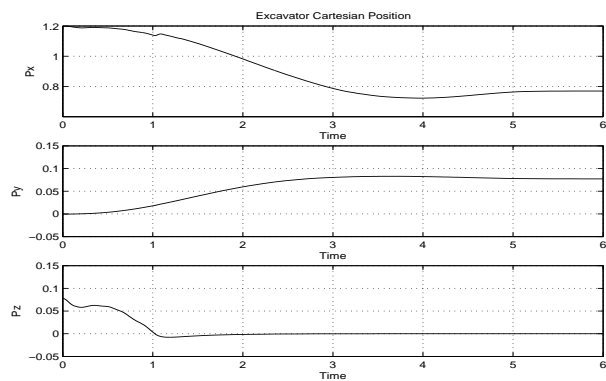

Fig. 6. Excavator cartesian position.

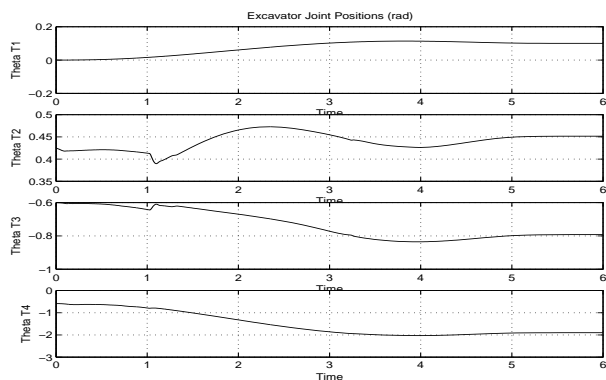

Fig. 7. Excavator joint position.

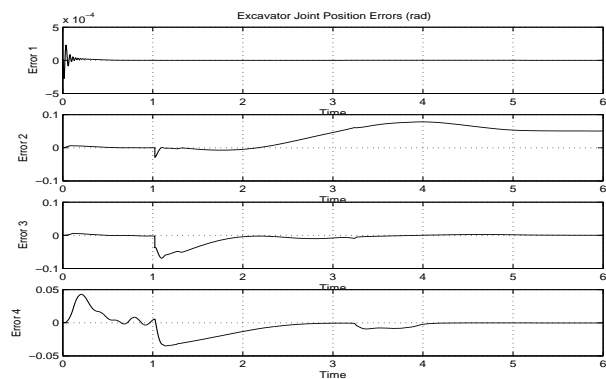

Fig. 8. Excavator joint position error.

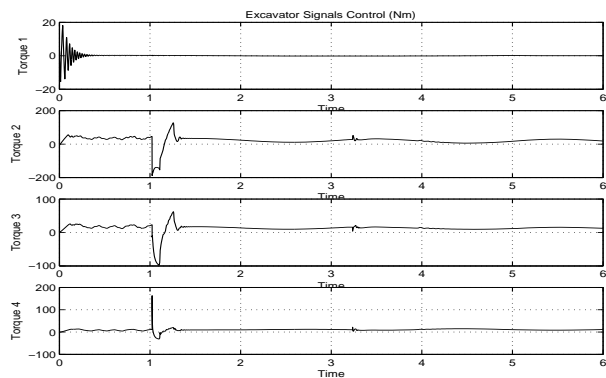

Fig. 9. Excavator signal control.

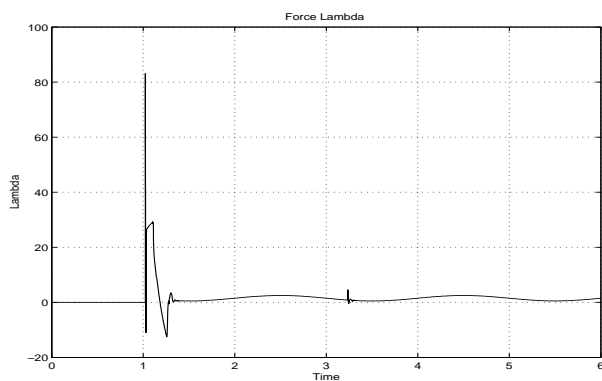

Fig. 10. Magnitude of force signal.

position tracking in free movement and a satisfactory force tracking in a constraint movement.

## REFERENCES

- Koivo A.J, Thoma, M. Kocaoglan E. Andrade-Cetto (1996). A. *Journal of Aerospace Engineering* **135**, 7–9.
- Parra, V. Arimoto, S. (1996). A passivity-based adaptive sliding mode position - force control for robot manipulators. *International Journal of Adaptive Control and signal Processing*. **66**, 267–269.
- Parra, V. Castillo, A. Arteaga (2002). Perfect tracking of force and position for constrained robot manipulators with orthogonal nonlinear pid control. *IEEE 3rd International Symposium on Robotics and Automation* **66**, 267–269.
- Simon P. DiMaio, S. E. Salcudean, Claude Reboulet S. Tafazoli K. Hashtrudi-Zaad (1998). A virtual excavator for controller development and evaluation. *ICRA* pp. 52–58.
- Stai, L.W (1963). *The mechanics of Serial and Parallel manipulators*. Wiley Interscience. London.
- Stentz, A. Bares, J. Singh S. Rowe P (1998). A robotic excavator for autonomus truck loading. *Proceedings of Internatinal Conference of Intelligent Robots and System* **35**, 123–126.
- Tafazoli, S. Lawrence, P.D. Salcucean F. (1999). Identification of inertial and friction parameters of excavator arm. *IEEE Transactions on Robotics and Autoation*.
- V. Parra-Vega, S. Arimoto, Y.H. Liu G. Hirzinger and P. Akella (2003). Dynamic sliding pid control for tracking of robot manipulators: Theory and experiments. *IEEE Transaction on Robotics and Automation* **19**, 976 – 985.