

AN IMPROVED FRICTION SLIDING MODEL FOR WEB HANDLING SYSTEMS. APPLICATION TO THE CONTROLLER PARAMETRIZATION

M. Vedrines ⁽¹⁾, D. Knittel ⁽²⁾

⁽¹⁾ INSA Strasbourg, LICIA

24, boulevard de la victoire, 67000 Strasbourg, FRANCE
marc.vedrines@insa-strasbourg.fr fax : +33 3 88 24 14 90

⁽²⁾ University of Strasbourg I, ERT Enroulement
IPST, 15 Rue du Mal. Lefebvre, 67100 Strasbourg, FRANCE.
dominique.knittel@ipst-ulp.u-strasbg.fr fax: +33 3 90 24 49 72

Abstract: In web transport systems, the main concern is to independently control speed and tension in spite of perturbations such as radius variations and changes of setting points. So far, simulation models representing web handling systems have only dealt with continuously rolling web without considering friction between web and rollers. This article aims at introducing the modeling of friction as well as the risk for the web to slide on traction rollers. The influence of several physical factors on the occurrence of such sliding is studied. In this paper, we focused on analyzing the special case of an emergency shutdown.

The authors observed and analyzed the consequences of several controllers on the occurrence or not of sliding. An approach for defining the optimal command to decrease the speed as fast as possible in the case of an emergency shutdown without occurrence of sliding is proposed. *Copyright © 2005 IFAC*

Keywords: winding systems, large scale systems, friction, sliding, slip, reference optimization.

1. INTRODUCTION

Web handling systems are very common industrial production plants used to transport materials such as textile, paper or polymers. Although modeling and control of web handling systems have been studied for several decades, increasing requirements on performances has lead to more sophisticated mechanical and control models. The most common goal is to increase web velocity as much as possible, while controlling web tension over the entire production line. This requires decoupling between web tension and speed, so that a constant tension can be maintained during speed changes. So far, many industrial web transport systems have used decentralized PI-type controllers (as illustrated in Fig.2). However, for higher control requirements more efficient control strategies must be used, e.g. LQG or H_∞ solutions. Most modern control law

designs need the elaboration and validation of the plant model. A detailed description of the model we use being given in (Koç *et al.*, 2002), we will only retain the principal laws on which it is based.

Robust control has already been applied to web handling for reduced-size systems, containing no more than 3 motors, with multivariable H_∞ centralized controllers (Koç *et al.*, 2002). Due to the wide-range variation of the roller radius during the winding process, the dynamic behavior of the system changes considerably with time. Thus, a substantial improvement has been obtained by the use of LPV controllers (Koç *et al.*, 2002).

So far, simulation models representing large scale web handling systems do not consider friction between web and rollers. The present study describes the introduction of friction and the possibility of sliding in the existing web handling simulation models. Accounting for friction and sliding in the

web handling systems can lead to performance deterioration in comparison to a system without friction. The models used for simulations were validated on a three-motor setup.

Part 2 shows the development of the nonlinear model dedicated to the bench simulation. Its linearization is used for controller design. The synthesis of the controller is summarized in part 3. The modeling of friction of the master traction roll is explained in part 4. The robust control without sliding is developed in part 5. The different cases of sliding occurrence are analyzed in part 6. Part 7 will conclude the paper.

2. PLANT MODELING

A scheme of a three-motor setup with PI controllers is represented on Fig.1. The inputs to the system defined by the dashed box are the torque reference signals (u_u , u_v , u_w) of the brushless motors; its measurements are the web tensions T_u and T_w and the web velocity V . This velocity is imposed by the master traction motor whereas the web tension is controlled by the unwinding and winding motors.

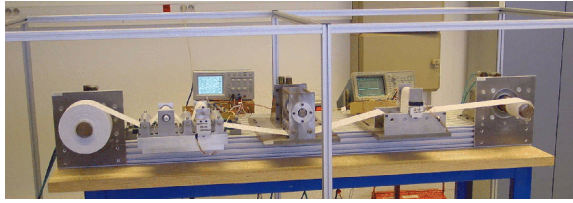

Fig. 1. Experimental setup with 3 motors and 2 load cells

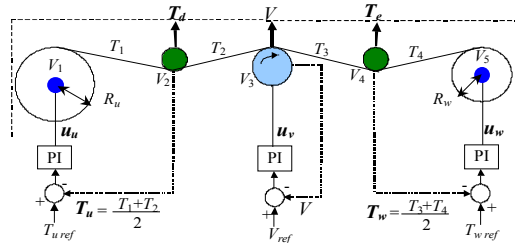

Fig. 2. Distributed PI control for a winding process

The nonlinear model (Koç *et al.*, 2002) of a web transport system is built from the equations of web tension behavior between two consecutive rollers and the equations describing the velocity of each roll.

A. Web tension calculation:

Modeling of web transport systems is based on three laws, which allow the calculation of web tension between two rolls.

1) As stated by *Hooke's law*, the tension T of an elastic web is function of the web strain ϵ :

$$T = ES\epsilon = ES \frac{L - L_0}{L_0} \quad (1)$$

where E is the Young elasticity modulus, S the web section, L the web length under stress and L_0 the web length without stress.

2) According to *Coulomb's law*, the study of a web tension on a roll can be considered as a problem of friction between solids.

3) *Equation of Continuity* applied to the web gives:

$$L \frac{dT_{k+1}}{dt} = ES(V_{k+1} - V_k) + T_k V_k - T_{k+1}(2V_k - V_{k+1}) \quad (2)$$

B. *Web velocity calculation:*

The linear velocity V_k of roll k is obtained from the torque balance (Koç *et al.*, 2002):

$$\frac{d}{dt} \left(J_k \frac{V_k}{R_k} \right) = R_k (T_k - T_{k-1}) + K_k U_k + C_f \quad (3)$$

in this equation $K_k U_k$ is the motor torque assumed equal to the reference value and C_f is the friction torque. Note that both inertia J_k and radius R_k of unwinder and winder are time dependent and vary substantially during processing.

C. *State space representation (Koç et al., 2002):*

The nonlinear state-space model is made of eq. (2) for the different web spans and eq. (3) for the different rolls. Under the assumption that J_k/R_k is slowly varying, which is the case for thin webs, V_k can be chosen as state variable in (3), leading to the following linear model (Koç *et al.*, 2002):

$$E(t) \frac{dX}{dt} = A(t)X + B(t)U \quad Y = C X \quad (4)$$

where: $Y = [T_u \ V_3 \ T_w]^T$, $U = [u_u \ u_v \ u_w]^T$
 $X = [V_1 \ T_1 \ V_2 \ T_2 \ V_3 \ T_3 \ V_4 \ T_4 \ V_5]^T$

3. GAIN SCHEDULING CONTROL

If we consider the unwinder and the winder separately, while keeping a quasi-static assumption on radius variations, the transfer function between control signal and web tension appears to be inversely proportional to the radius:

$$\lim_{s \rightarrow 0} \frac{T_1(s)}{u_u(s)} \cong \frac{K_u}{R_u} \quad \lim_{s \rightarrow 0} \frac{T_4(s)}{u_w(s)} \cong \frac{K_w}{R_w} \quad (5)$$

Based on this observation, a new plant is obtained by multiplying the controller output signals u_u and u_w by the radius R_u and R_w respectively. This new plant has the advantage of making the gain at low frequency less dependent on radius and inertia. Therefore, gain scheduling improves robustness to radius variations; it is used in control strategies presented in the sequel.

4. MODELISATION OF ADHESION AND SLIDING OF THE WEB

Bastogne (2002) proposed a model representing the occurrence of sliding between a web and a single roll. Using the same procedure considering the web as a rigid body, we propose here a new formulation of the acceleration, and from the same local equations, a different way of determining whether there is sliding or not, and then, the implementation of this model in a more complex system: our three motors bench simulator.

Considering an elementary part of the web of angular value $d\theta$:

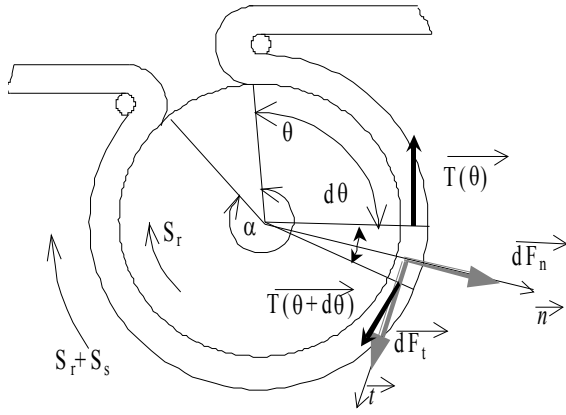

Fig 3 : master traction roll

In Fig. 3, dF represents the tangential force, and dF_n the normal force between the roll and the web, $T(\theta)$ and $T(\theta+d\theta)$ the action of the web before and after the elementary volume on the roll. α is the wrap angle. T_u is the web tension before and T_w after the master roll.

It is now necessary to consider that the speed S_r of the master roll can be different from the web speed. The rotational web speed is S_r+S_s , S_s being the sliding speed. The acceleration of the elementary volume is

$$\vec{r} = -R(S_r + S_s)^2 \cdot \vec{n} + R(\dot{S}_r + \dot{S}_s) \vec{t} \quad (6)$$

in this equation R is the radius of the traction roll. Equations (7) and (8) are obtained from the implementation of the fundamental principle of dynamics applied to an elementary part of the web in contact with the master roll. The equilibrium of an elementary volume of the web gives the equations (7) and (8) using the projection on \vec{n} and \vec{t} in the polar coordinate system:

$$\begin{aligned} & -[T(\theta + d\theta) + T(\theta)] \sin\left(\frac{d\theta}{2}\right) + dF_n(\theta) - dm \cdot g \cdot \cos(\theta) \\ & = -dm \cdot R \cdot (S_r + S_s)^2 \end{aligned} \quad (7)$$

and

$$\begin{aligned} & -[T(\theta + d\theta) - T(\theta)] \cos\left(\frac{d\theta}{2}\right) - dF_t(\theta) + dm \cdot g \cdot \sin(\theta) \\ & = dm \cdot R \cdot (\dot{S}_r + \dot{S}_s) \end{aligned} \quad (8)$$

where dm is the mass of the elementary volume and E the web Young modulus.

Locally, the relationship between dF_t and dF_n is set by the friction law:

$$dF_t = \mu(F_n, S_s) dF_n \quad (9)$$

This law has to be chosen according to the application. In this presentation, we will consider a basic friction model where μ_s is the static coefficient, and μ_d is the dynamic coefficient during sliding.

In (Bastogne, 2002), the evolution of the web tension on the roll is an hypothesis which is supposed to be linear according to the relation :

$$T(\theta) = T_u + \frac{T_w - T_u}{\alpha} \theta \quad (10)$$

and this linear evolution is then used to calculate F_t and F_n .

In this paper, a new approach using the combination of equations (7), (8) and (9) leads to :

$$\frac{dT}{\mu[T(\theta) - \lambda]} = d\theta \quad (11)$$

which gives :

$$T(\theta) = (T_u - \lambda) \cdot e^{\mu\theta} + \lambda \quad (12)$$

where :

$$\lambda = \frac{\rho AR}{\mu} [R(S_r + S_s)^2 - R(\dot{S}_r + \dot{S}_s)] \quad (13)$$

A is the area of the web section and ρ the density.

The evolution of the web tension is not linear but now exponential. From equation (12), it is possible, as T_w (tension for $\theta = \alpha$) and T_u (tension for $\theta = 0$) are input of the problem, to calculate a theoretical value of μ : μ_{th} .

We chose to use the idea of a logical treatment introduced by (Bastogne, 2002) to determine whether the web is sliding on the master roll or not, but in our case the decision is made on the value of μ_{th} instead of comparing the value of F_t to border values as made by Bastogne (2002).

The sliding state is represented by a logical parameter $G(t)$, which is equal to 1 when there is sliding and to 0 otherwise. The logical equation governing the sliding / adhesion variable $G(t)$ is :

$$G(t) = [\text{not } G(t-1) \text{ and } | \mu_{th}(t) | > \mu_s] \text{ OR } [G(t-1) \text{ and } | S_s(t) | > \Delta_s]$$

Equation (7) gives :

$$dF_n = T(\theta) d\theta - \rho AR [R(S_r + S_s)^2 - g \cos \theta] d\theta \quad (14)$$

and by integrating from $\theta = 0$ to $\theta = \alpha$, we obtain the resultant forces :

$$\begin{aligned} F_n &= \frac{T_u - \lambda}{\mu} (e^{\mu\alpha} - 1) + \lambda\alpha \\ & - \rho \cdot A \cdot R \left[(S_r + S_s)^2 \alpha - g \cdot \sin \alpha \right] \end{aligned} \quad (15)$$

the relationship (9) gives F_t .

The evolution of G as a logical value governing the behaviour of the web (Bastogne 2002) generates discontinuities of physical values and therefore introduces instability in the system. It is important to implement a continuous equation (9) as made in the paper of Schraberger and Brandenburg (Schraberger *et al.*, 2001). As a consequence, we use here a basic friction model where we considered that $\mu_s = \mu_d$. A more sophisticated friction model may be necessary to account for an accurate behaviour in the sliding area. Papers of Brandenburg and Schraberger (Schraberger *et al.*, 2001), modelling the Stribeck effect, set the basis of a further implementation of the sliding behaviour.

The integration of equation (8) gives :

$$\begin{aligned} F_t &= -T_u + T_w + \rho AR (-g(\cos \alpha - 1)) \\ & - R(\dot{S}_r + \dot{S}_s) \end{aligned} \quad (16)$$

S_s can be integrated from the equation (16) and is reset to zero as long as there is no sliding. This action was not implemented in the original roll model (Koç *et al.*, 2002), (Knittel *et al.*, 2003).

As a result of this new model, it is now possible to detect the occurrence of sliding and to calculate the sliding speed S_s .

This model has been implemented into the three motors setup. The friction factor has been approximated to $\mu = 0.25$. Some experiments are currently carried out to identify experimentally the friction effects. The structure of the 3-motors setup simulator in Matlab/Simulink environment is presented in the Appendix.

5. ROBUST CONTROL WITHOUT SLIDING

The coupling between web velocity and tension makes the control of web transport systems inherently difficult. Several methods to suppress this coupling in a system with two driven rolls have been studied (Jeon *et al.*, 1999) (Panda *et al.*, 2002). For the past several years, we have developed 1DOF or 2DOF multivariable strategies based on H_∞ and LPV using different mixed sensitivity schemes (Koç *et al.*, 2002), (Xu *et al.*, 2003), (Knittel *et al.*, 2003). These methods have significantly improved the tracking properties and quasi suppressed the coupling.

The controller used in the following paragraphs was calculated with H_∞ optimization using a S/KS/T synthesis scheme with model matching. In figure 4 are shown simulations with such type of controller applied to our 3-motor model. In this case no sliding between web and master roll occurs (represented by parameter G). As expected, the same dynamic and static behaviour was obtained with the model where the possibility of sliding was neutralized.

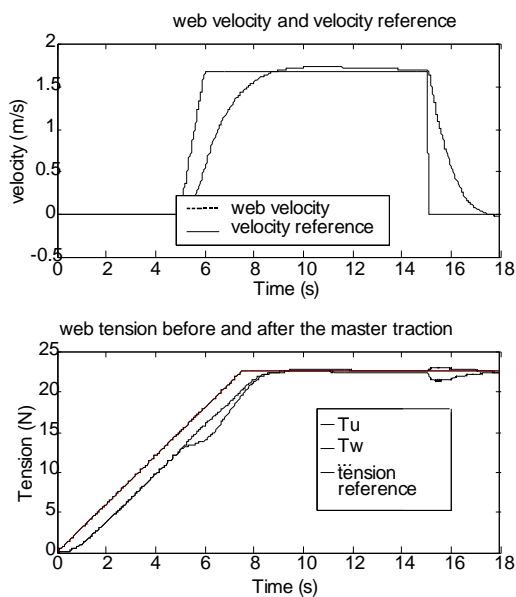

Fig 4 : velocity and tension simulations obtained with a model without sliding

The simulations are done with the following nominal values: $\rho = 500 \text{ kg/m}^3$, $E = 160 \text{ Mpa}$, $\alpha = 3\pi/2$, web thickness = 0.26 mm, web width = 100 mm.

6. STUDY OF SLIDING OCCURRENCE

The occurrence of sliding will be detected in the particular case of a fast decreasing speed. This stands for the industrially very common case of an emergency shutdown. In most cases, when the speed set point command is rapidly set to zero, the web span will slide, and the entire system will be out of control. One of our primary concerns is to keep the control of the system during the entire phase of slow down.

A) Effect of the velocity tracking improvement

The velocity tracking response of the controller synthesized in part 5 can be improved. In such case, the reference model used for the controller computation has to be faster.

Fig. 5 shows the tensions and velocity responses with two different controller tunings : the one is the controller applied in simulations represented on figure 4, the second used the same synthesis scheme but with a faster reference model. In this figure 5, great oscillations in tensions and speed occur at 15.07s in the case of sliding for the fastest controller.

The evolution of the parameter G , which represents the sliding, shows that the sliding appears at that time (see Fig. 6).

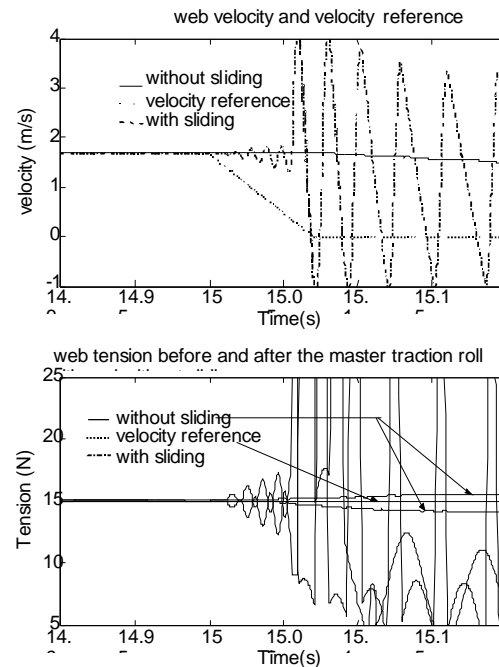

Fig 5 : behaviour of the model in the case of sliding

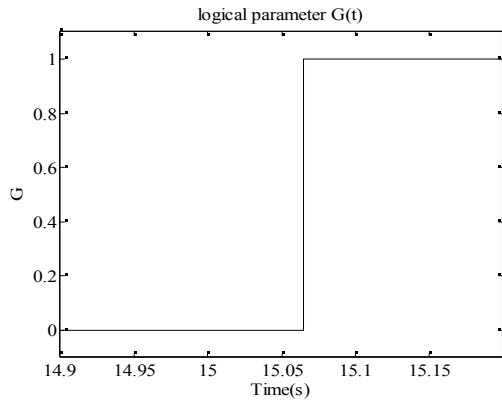

Fig 6 : sliding parameter G in the case of sliding.

In the controller synthesis scheme, the tuning of the reference model allows to find the fastest controller without sliding.

More specific controllers for sliding reducing or avoiding are used in anti-lock brake systems (ABS) for cars (Petersen et al., 2003) (Solyom, 2002).

B) Optimization of the velocity reference slew rate

For a given controller, the occurrence of sliding is determined by the velocity slew rate. The limit slew rate can be found with our simulator, and it is affected by several physical parameters.

C) Influence of several physical parameters

For a given controller, the fastest velocity slew rate avoiding sliding depends mostly on three physical parameters ρ , E , μ and a reference T_w (equal to the reference T_u in our simulation case).

Figure 7 shows an example of the relationship between the maximum velocity slew rate and the friction coefficient between web and roll.

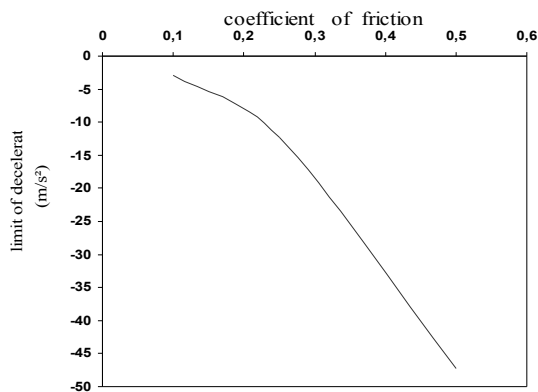

Fig 7: influence of the friction coefficient on the limit of velocity deceleration.

It is interesting to range the sensitivity of each factor x (i.e. ρ , E , T_w or μ) to on the limit of deceleration Γ (maximum velocity slew rate).

The sensitivity $(d\Gamma / dx)$ has been determined at the nominal point :

Table 1 : influence of several physical factors on the limit of deceleration

Parameter	$(d\Gamma / dx)$
ρ	0,0004
E	0,0068
$T_w = T_u$	0,8867
μ	68,67

Obviously, the density ρ has a very little influence on the deceleration rate. We observed that for a higher Young modulus, the system can be stop faster without sliding. We have also observed that for higher web tension, the system can be shut down faster.

D) Identification method for the friction coefficient

The coefficient of friction will be calculated using the measured values of band tension T_w and T_u and wrap angle α in the case of friction on the three motors

experimental setup : $\mu = \frac{1}{\alpha} \ln\left(\frac{T_w}{T_u}\right)$.

7. CONCLUSION

Web winding systems require an efficient control of the tension and the velocity during the whole process. Modern control strategies require the elaboration of an accurate plant model. Unfortunately the different web handling models published in the litterature don't consider the sliding case between web span and driving rolls. This paper presents a 3-motor plant model including a friction sliding model located on the master roll. Sliding occurrences are analysed and investigated. The influence of the velocity deceleration and the controller tracking behavior are particularly focused on. The friction coefficient is the main factor governing the limit of velocity deceleration. Its value and therefore its influences will have to be determined experimentally on our real bench. This will be the subject of future investigations.

ACKNOWLEDGMENTS

The authors wish to thank the French Ministry of Research for financial support through the project "Winding and high velocity handling of flexible webs" (ERT, contract number 01 B 0395).

REFERENCES

Bastogne, T., A. Richard (2002), Modélisation et simulation d'un système d'entraînement de bande en présence de glissement, *CIFA 2002 – Conférence Internationale francophone d'Automatisme*, Nantes.

- Christen, U.(1996), Engineering aspects of H_∞ control. *PhD thesis*, Swiss Federal Institute of Technology, Zurich.
- Grimble, M. J., G. Hearn (1999). Advanced control for hot rolling mills, *Advances in control, Highlights of ECC'99*, Springer, pp. 135-169.
- Knittel, D., D. Gigan, E. Laroche (2002). Robust decentralized overlapping control of large scale winding systems, *American Control Conference, Anchorage*.
- Knittel, D., E. Laroche, D. Gigan, H. Koç (2003). Tension control for winding systems with two degrees of freedom H_∞ controller, *IEEE Transactions on Industry Applications* 39(1), pp. 113-120.
- Koç, H., D. Knittel, M. de Mathelin and G. Abba (2002). Modeling and robust control of winding systems for elastic webs. *IEEE Transactions on Control Systems Technology* 10(2), pp. 197-208.
- Petersen, I., T. A. Johansen, J.K. Kalkkuhl, J. Lüdemann (2003). Wheel slip control using gain-scheduled LQ – LPV/LMI analysis and experimental results. European Control Conference ECC'03, Cambridge.
- Panda, S. P., A. P. Engelmann (2002). Modelling and control system design of reel-to-reel tape drives. *American Control Conference, Anchorage, USA*, Schraberg, G., M. Lauzi, G. Brandenburg (2001), *Vergleich verschiedener Ansätze zur Simulation von Reibungseffekten und deren Verifikation an einem Vorschubantrieb*, *Antriebstechnik*, N°43, Heft 9, pp. 35-43.
- Siljak, D. D. (1991), Decentralized control of complex systems, Academic press.
- Solyom, S. (2002). Synthesis of a model-based tire slip controller. PhD Thesis, Lund Institute of Technology.
- Van Antwerp, R. Braatz (2000), Identification and control of sheet and film processes, Springer.
- Xu, Y., D. Knittel, M. de Mathelin (2003) Two-degrees-of-freedom gain scheduled control for quasi-periodic disturbance rejection: application in the unwinding of an eccentric roll. *IFAC ROCOND'03, Milan, Italy*
- Zhou, K., J. Doyle, K. Glover (1995). Robust and optimal control, *Prentice Hall*, Upper Saddle River, New Jersey. pp. 927-933

APPENDIX

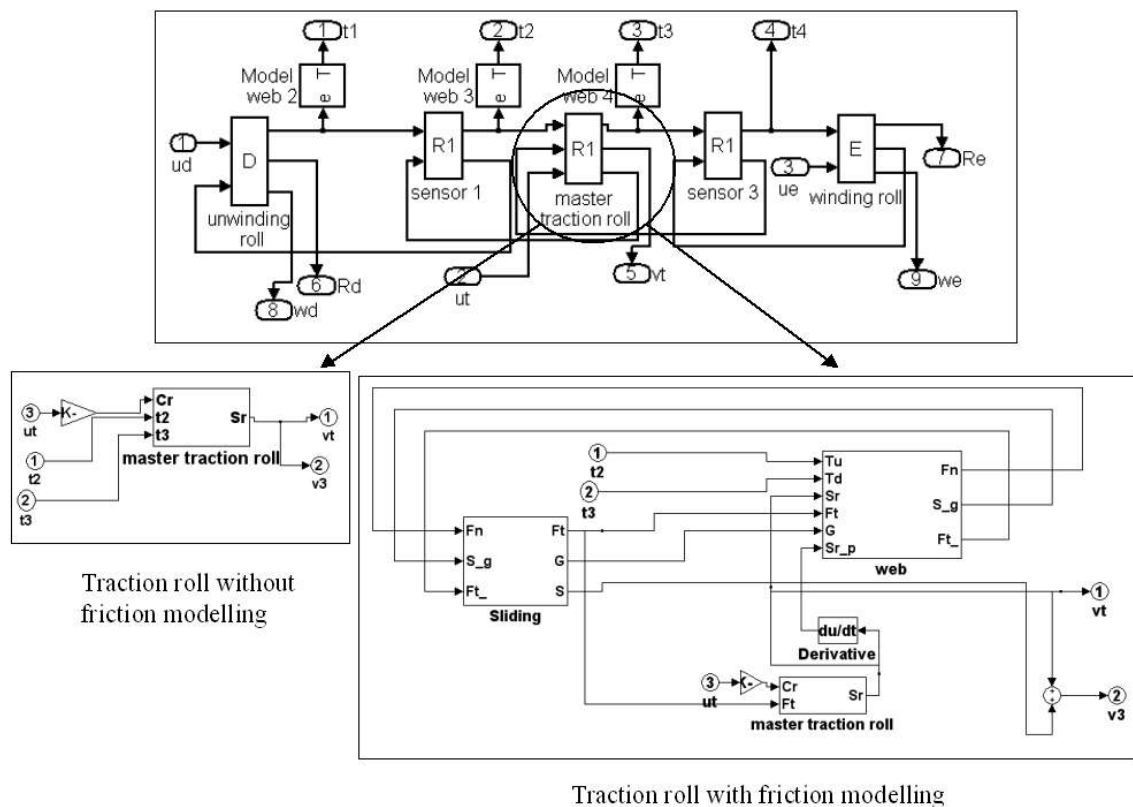

Fig 8: Structure of the 3-motor setup simulator in Matlab/Simulink environment