

A PARAMETRIC ROBUST APPROACH PID CONTROL FOR A LAPAROSCOPIC SURGERY ROBOT

Yolanda Bolea, Pere Dot, Damià Pujol, and Antoni Grau

Automatic Control Dept, Technical University of Catalonia, UPC,
Barcelona, Spain
e-mail: yolanda.bolea@upc.edu

Abstract: This paper presents an innovative H_{∞} robust controller PID with parametric approach. The non-linearity uncertainties, the time-varying system and other parameters' variations are taken into account in its design. Furthermore, this type of controller (of low order) is frequently used for industrial purposes due to its simplicity and straightforward implementation in comparison with the high order controllers that H_{∞} technique yields. The goodness of this kind of controller for robotics systems has been tested in a 3-dof laparoscopic surgery robotic arm. *Copyright © 2005 IFAC*

Keywords: H_{∞} , robust control, parametric robust control, PID, linealization, robotics.

1. INTRODUCTION

Robotics has attracted an ever-increasing number of control researchers in the last twenty years, producing a visible cross-fertilization between the two fields. As automation becomes more prevalent in medicine it should be clear that the traditional PID is no longer a satisfactory means of control in many situations. Optimum performance for operations seems more convenient for the surgeon. Then, lastly, robotics systems are used for interventions as laparoscopic (Krupa, *et al.*, 2003), physiotherapy (Richardson, *et al.*, 2004), etc. This type of systems demands the use of such approaches as robust control (Koo, *et al.*, 1994), adaptive control (Craig, *et al.*, 1987; Egeland, *et al.*, 1994), intelligent control (Kang, 1998) and the like.

Recently it is widely used the robust control that needs usually a fixed controller design to satisfy stability and performance specifications over given range of uncertainty. This control approach is important in robotics engineering because a robotics system has very strong nonlinear characteristics (error

models, several operating points, not to take into account the actuators dynamics, high frequencies and other internal/external disturbances) and, often, contains variable system parameters (masses, loads and frictions) in a real environment. The robust control presents two approaches: the parametric (Bhattacharyya, *et al.*, 1995) and the non-structured (Skogestad, *et al.*, 1997). Although uncertainty model is better known in the first case, control is less conservative in the second one. The main motivation to use robust control with a parametric approach has been the possibility of designing a PID (of low order) even when the model has a higher order. Despite this methodology does not capture the uncertainty too much detailed (unstructured), it provides an allowable set of controllers to choose the more suitable to obtain the desired specifications.

The paper is distributed as follows¹. In Section 2 the robotics system and the dynamic modeling are described; in Section 3 an H_{∞} robust controller with

¹ This work has been supported by the DPI2004-5414 project of the Science and Technology Spanish ministry.

parametric approach design will be presented showing the uncertainties due to the non-linearity of the robot dynamic, in this case the actuators dynamics and high frequencies have not been taken into account. Some interesting results are showed in Section 4.

2. PROBLEM DESCRIPTION

The robotic system consists on a three-link rigid manipulator which has been developed at the Robotics System Laboratory in the Technical University of Catalonia, UPC, (Amat, 2001). The system includes a 3-dof (degree-of-freedom) industrial robot specifically designed for laparoscopic surgery. The arm holds a video camera in order to accomplish the robot objective: to follow the end of any tool the surgeon would like to track inside an abdomen. An industrial PC contains the video acquisition card and the analog input/output card to supply current to the robot actuators and position sensors reading. Fig. 1 shows the system configuration of this manipulator, (Dot and Pujol, 2004), in a laparoscopic surgical trainer.

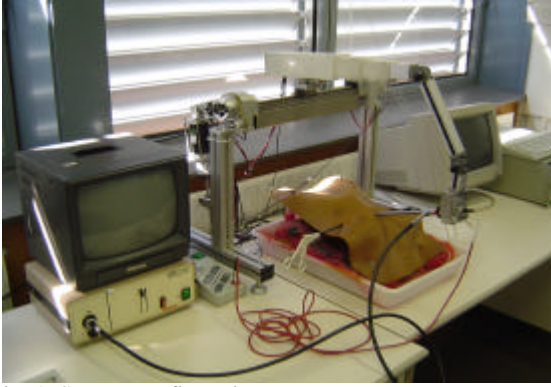

Fig. 1. System configuration.

2.1. Dynamic Complete Model

The complete physics of manipulators can be classified into two categories: cinematic and dynamic modeling. Both the cinematic and dynamic modeling rely on an accurate knowledge of a number of constant parameters characterizing the mechanical structure, such as link lengths, masses and inertial properties. The cinematic modeling of a manipulator concerns the description of the motion of the manipulator with respect to a fixed reference frame by ignoring the forces and moments that cause the actuators.

The system model consists of a complete model that, accurately and globally, describes the dynamics of the laparoscopic robot. According to the constrained Lagrange-Euler theory and neglecting the friction vector, the robotic system can be expressed as

$$\mathbf{t} = \mathbf{M}(q)\ddot{q} + \mathbf{C}(q, \dot{q}) + \mathbf{G}(q) + \mathbf{F}(\dot{q}) \quad (1)$$

where \mathbf{t} are the applied torques, $q \in \mathfrak{R}^n$ consists on the joint variables (the generalized coordinates), $\dot{q} \in \mathfrak{R}^n$ is the generalized velocity, $\ddot{q} \in \mathfrak{R}^n$ is the acceleration, $\mathbf{M}(q) \in \mathfrak{R}^{n \times n}$ is the generalized moment inertia matrix, $\mathbf{C}(q, \dot{q}) \in \mathfrak{R}^n$ is the centripetal and Coriolis forces vector, $\mathbf{G}(q) \in \mathfrak{R}^n$ is the gravitational forces vector and $\mathbf{F}(\dot{q}) \in \mathfrak{R}^n$ is the friction vector.

In this case, these matrices can be expressed as

$$\mathbf{M}(q) = \begin{bmatrix} m_{11} & m_{12} & m_{13} \\ m_{21} & m_{22} & m_{23} \\ m_{31} & m_{32} & m_{33} \end{bmatrix}; \mathbf{C}(q, \dot{q}) = \begin{bmatrix} c_1 \\ c_2 \\ c_3 \end{bmatrix}; \mathbf{G}(q) = \begin{bmatrix} g_1 \\ g_2 \\ g_3 \end{bmatrix}$$

$$m_{11} = \frac{1}{4}a_2^2m_2 + m_3a_2^2 + m_3s_3^2 + m_3d_3^2 + m_3h^2 - m_3a_2h - m_3ha_2 + 2m_3d_3s_3;$$

$$m_{13} = a_2m_3 - m_3h; \quad m_{22} = m_3 + m_2;$$

$$m_{31} = -hm_3 - a_2m_3; \quad m_{33} = m_3;$$

$$m_{12} = m_{21} = m_{23} = m_{32} = 0;$$

$$c_1 = 2m_3s_3\dot{q}_1\dot{s}_3 + 2m_3d_3\dot{q}_1\dot{s}_3; \quad c_2 = 0;$$

$$c_3 = -m_3\dot{q}_1^2d_3 - m_3\dot{q}_1^2s_3;$$

$$g_1 = -\frac{1}{2}a_2m_2g\sin(q_1) + m_3hg\sin(q_1)$$

$$- (d_3 + s_3)\cos(q_1) - a_2\sin(q_1);$$

$$g_2 = 0; \quad g_3 = -m_3g\sin(q_1);$$

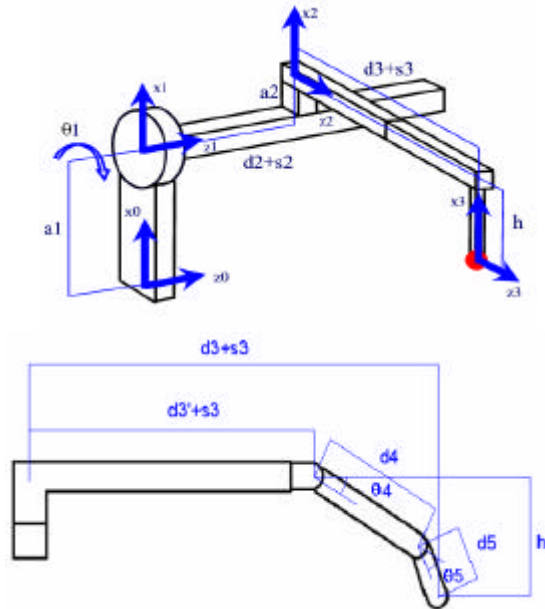

Fig. 2. (Up) Robot scheme with its parameters; (down) robot system angles representation.

$\mathbf{F}(\dot{q}) = \mathbf{F}_m\dot{q} + \mathbf{T}_{df}$, \mathbf{F}_m is the diagonal viscous friction constants matrix and \mathbf{T}_{df} represents other non-structural effects (resonances), i.e., the Coulomb friction constants vector. The final robot variables are

q_1 (the revolution joint) and s_2 and s_3 (translation joints 2 and 3). The parameters nominal values of the robot can be seen in Table 1. The joints 4 and 5 will be neglected in this study because they do not permit any rotation, anyway their constants q_4 and q_5 are needed in the calculations.

This dynamic model derives the direct cinematic model from the Denavit-Hartenberg algorithm.

Table 1. Nominal parameters of the laparoscopic surgery robot.

Distances [m] (see Fig. 2)	a_1	0.42
	a_2	0.095
	d_2	0.30
	d_3	$0.34 + d_4 \cos(q_4) + d_5 \cos(q_4 + q_5)$
	h	$d_4 \sin(q_4) + d_5 \sin(q_4 + q_5)$
	d_4	0.25
	d_5	0.135
Masses of links 2 and 3	m_2	2.193 [kg]
	m_3	1.205 [kg]
Viscous friction constants of links 1, 2 and 3	b_1	1 [kg·m ² /rad]
	b_2	1 [kg·m]
	b_3	1 [kg·m]
Coulomb friction constants of links 1, 2 and 3	C_{f1}	1
	C_{f2}	1
	C_{f3}	1

2.2. Control Scheme and Control Objectives

The control objective is to design a robust control scheme to track the laparoscopic instrument (tool) with sufficient precision to avoid damaging the patient. Thus, only position measurements are used i.e. joint space controllers (Berghuis, *et al.*, 1994; Richardson, *et al.*, 2004).

X-Y-Z space coordinates (3D) determine where the terminal element of the robot has to be located. This spatial position is the reference (x_d, y_d, z_d) to the controller in order to move the robot arms to reach such a position. In the diagram of Fig. 2, the variables are: the desired robot position (q_{1d}, s_{2d}, s_{3d}) in the joint-space is obtained by inverse cinematic model (ICM) transformation; the (x, y, z) is the actual position of the robot arms after the direct cinematic model (DCM) transformation; and the control signals, (u_1, u_2, u_3) , give voltage to each joint. In Fig. 3 the control loop is shown.

Despite the robot is a coupled MIMO system, that is, the s_2 joint is independent of the applied torques to the other joints, but q_1 and s_3 are coupled, a decentralized control scheme is applied because the algorithm is SISO, and the MIMO systems analysis adds an unnecessary difficulty due to the fact that uncertainty model takes into account the coupling of joints 1 and 3.

The decentralized control is suitable when the conditions in (Skogestad, *et al.*, 1997) are fulfilled, warranting the global stability with SISO-designed controllers. That happens in our system and besides, as far as practical applicability is concerned, decentralized controllers offer important advantages over centralized controllers like: the control system is simpler, the impact of a communication failure and breakdown of electrical power is more limited if the control system is implemented locally and the communication systems and other electronic devices can be cheaper (compared with the systems needed for a fully centralized control system).

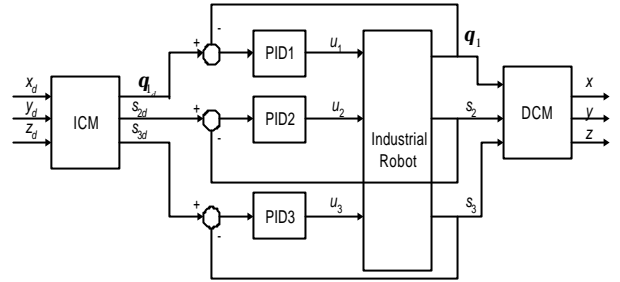

Fig. 3. Control loop system.

As usually, robotic control problem consists of tracking a given path in the presence of physical and task constraints. Physical constraints consist of joint torque limits, due to joint-motor voltage saturation, joint velocity and acceleration limits, as well as limits on joint positions for reasons of mechanical constructions. These constraints can be taken into account in robot motion planning studying the problem either in joint space, which leads to joint-space trajectory plan and motion control, or in robot workspace. In our case the limit constraint exists for the three control variables, $-5V \leq u_i \leq 5V$, $i = 1, 2, 3$, and the robot partially-spherical working area is bound by: $x \in [0.04, 0.16]$ m, $y \in [0.29, 0.38]$ m and $z \in [0.2, 0.4]$ m. The essential desired specifications must satisfy the requirements of robust stability and robust performance while the control inputs remain inside the range of operation of the actuators.

3. ROBUST PID CONTROL DESIGN

The use of robust control methods is motivated by the necessity to control the motion of robots where modeling errors are present, and lightly damped modes and unstable zeros make the control quite difficult. Also, these methods overcome the limitations of the proposed linear designs. For this reason the use of H_∞ control is proposed in this article. Though this technique gives high-order controllers and is difficult to implement, it is preferable to design an optimal robust H_∞ controller with a parametric approach that will allow the synthesis of low-order controllers with PID structure, ease to implement and to resintonize and non-fragile. The control algorithm used in this application was

introduced in (Ho, 2003), and this is a computationally efficient procedure for carrying out H_{∞} PID optimal design instead of brute force optimization search procedure (Datta, *et al.*, 2000). That leads to a complex version of the generalized Hermite-Biehler Theorem for solving H_{∞} PID optimal design problem considering uncertainties of the model.

3.1. Model for Control and Uncertainty Model

The control model formulation is an approximation to the complete model in (1). This model is linearized, (Shamma, 1995), in its nominal point $(\mathbf{q}_{1nom}, s_{2nom}, s_{3nom}) = (0, 0, 0)$ [rad, m, m]. Joints 1 and 3 of the laparoscopic robot present load and inertia variations, frictions, non-modeled dynamics, external disturbances, parameters subject to change due to robot working area and working conditions, couplings, etc., provoking that control model neglects part of their dynamics and presents errors which are captured by unstructured multiplicative uncertainties at the plant output (Koo, *et al.*, 1994; Skogestad, *et al.*, 1997).

$$l_m(j\omega) = \max_{G \in \Pi} \left| \frac{G(j\omega) - G_0(j\omega)}{G_0(j\omega)} \right|$$

where G_0 is the transfer function of the nominal plant, G is the transfer function that represents one of the plants in the possible set of plants Π . The uncertainty $l_m(s)$ is bounded by a rational function $l_m(s) : W_T(s)\Delta(s)$, with $|\Delta(s)| < 1$, so that $|l_m(j\omega)| \leq |W_T(j\omega)| \quad \forall \omega \in \mathfrak{R}$. $|\Delta(s)|$ is the normalized uncertainty, $W_T(s)$ is the frequency weighting function (rational and stable transfer function).

These robustness weight functions are chosen as:

$$\text{joint 1: } W_{T_1}(s) = \frac{0.1s + 1}{0.025s + 1}$$

$$\text{joint 3: } W_{T_3}(s) = \frac{0.1s + 1}{0.01s + 1}$$

Joint 2 is not affected by the above properties and the linearized model does not present significant uncertainties. Therefore, in our problem is remarkable to note that the robustness is estimated with the use of a bound on multiplicative uncertainty taking into account the model errors, due to the nonlinear dynamics of the system. The violation of such constraints may lead to poor control performance and possibly closed-loop instability.

3.2. Controller Design

The robust methodology of control chosen to compute independently the controllers of each joint is based in the use of the characterization of all PIDs to design

the controllers of this type that minimize certain performance indices like the criterion H_2 , H_{∞} , etc. In this case, it can be considered as a mixed sensitivity optimization problem (see Fig. 4), finding a stabilizing controller that minimizes the cost function

$$\left\| \begin{bmatrix} W_{S_i} S_i & W_{KS_i} K S_i & W_{T_i} T_i \end{bmatrix} \right\|_{\infty}^T.$$

Choosing the correct weights, a robust tracking performance (S), a limitation of the size and bandwidth of the controller and hence the control energy used (KS), stability (T), and the rejection to disturbances (measuring noise and external disturbances) can be achieved. These weights will be the same for all the joints ($W_{S_i} = 0.5$, $W_{KS_i} = 1$).

From (Hoo, 2003) the set of stabilizing values (K_p , K_i , K_d) for each joint of the plant is obtained. For clarity in the representation the stabilizing regions of each controller will be denoted by St_1 , St_2 and St_3 for joint 1, 2 and 3 respectively.

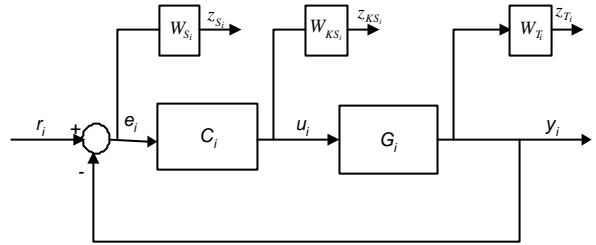

Fig. 4. $S/KS/T$ mixed-sensitivity optimization in standard form for each joint i .

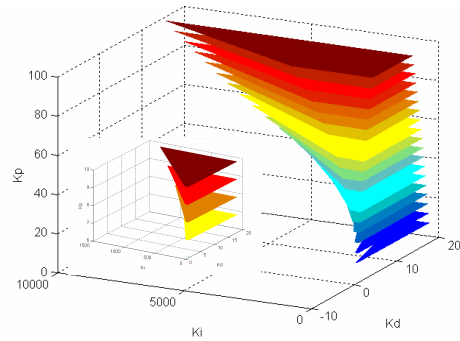

Fig. 5. Stabilizing region St_1 .

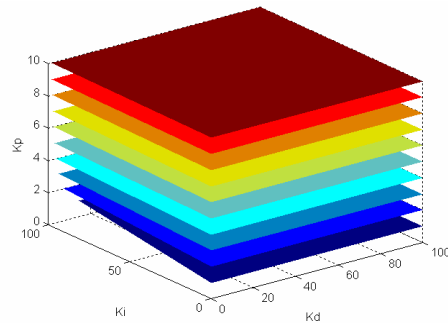

Fig. 6. Stabilizing region St_2 .

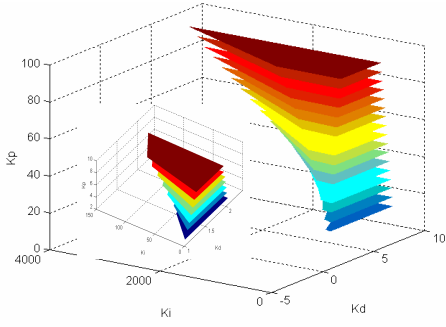

Fig. 7. Stabilizing region St_3 .

The approximate admissible sets of PID parameter values, that ensure the system's stability for all perturbations in the uncertainty set fulfilling the robust stability for each joint ($\|W_{T_i} T_i\|_{\infty} < 1$), are represented in Fig. 5, 6 and 7.

Though in the design of these controllers the performance criteria H_Y is used, many possible controllers and an interval set of PIDs are obtained, being this robust control technique less conservative than the classical H_Y control.

The performance specifications and the limitation of input control are specified by the analysis and temporal study of the influence of the PIDs in all the possible closed-loops. For the test of these specifications, the condition of robust performance $\|W_{S_i} S_i\|_{\infty} < 1$ and the limitation of the control signal $\|W_{KS_i} KS_i\| < 1$ for each joint are used.

4. SIMULATION RESULTS AND DISCUSSION

The previous procedure is applied to the laparoscopic robot described in Section 2. For checking the goodness of our method a significant desired trajectory is selected which is bounded in a larger operating space, $x_d(t) = 0.05 \sin(t) + 0.105$, $y_d(t) = 0.04 \cos(t) + 0.33$ and $z_d(t) = 0.1 \sin(t) + 0.3$.

The goal is to develop and apply a control law that ensures robustness and good performance level of the flexible arm behavior. The performance measurements of the controlled system are specified in terms of temporal characteristics. Robustness to parameter changes and to uncertainties is specified by bounds on the sensitivity functions and by the fact that the control law must achieve a performance level for the proposed configuration of the surgery arm.

Then, control system closed-loop temporal behavior analysis has been carried out for all the possible PIDs and the following values have been chosen: i) joint 1: $K_p = 60$, $K_i = 20$, $K_d = 10$; ii) joint 2: $K_p = 10$, $K_i = 0$, $K_d = 20$; and iii) joint 3: $K_p = 100$, $K_i = 70$, $K_d = 10$. This controller ensures a robust, precise, and

sufficient fast behavior (faster poles result in larger control signals, which would breach the saturation limit and result in poor controller performance or instability), fulfilling always the stability criterion (global stability condition by decentralized control (Yang, *et al.*, 2001)):

- **Robustness.** 1) Robust stability: the flexible arm remains stable in this study case (see Fig. 8 (up)), reaffirming that the controller is robust in front modeling uncertainties and coupling generated by joints 1 and 3. The robot moves in the whole working area, varying the parameters in their maximum range. For the uncertainty worst case bound the robust stability conditions and the reject to disturbances (couplings) are fulfilled for each joint. 2) Robust performance: the sensitivity functions are bounded by W_{S_i} for each joint, and the S mixed sensitivity problem is fulfilled, see Fig. 8 (down).

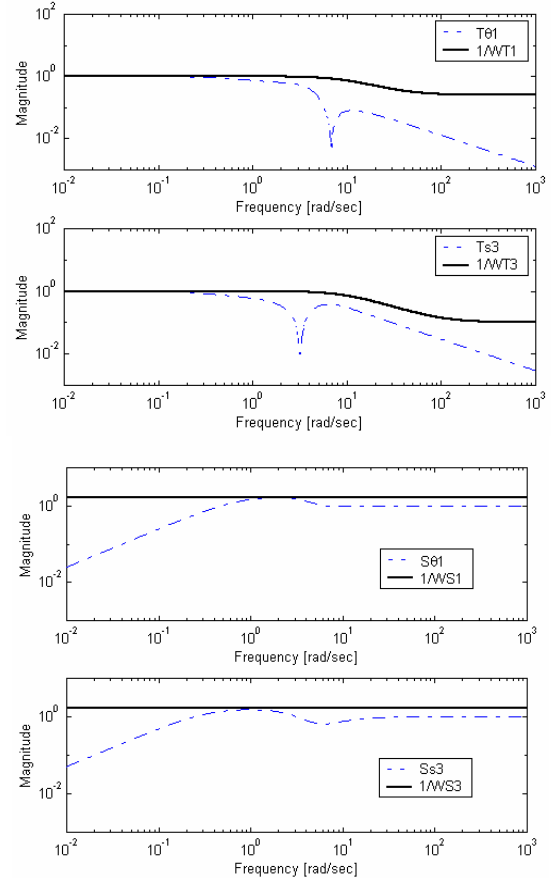

Fig. 8. (Up) Robust stability; (down) robust performance.

- **Tracking performance:** Fig. 9 shows the results of the variation in the (x,y,z) position that follows the actual terminal element of the robot. A short delay is present in the x position response, however the magnitude of the response is correct. The y position tracking has the correct shape nevertheless the magnitude of motion is less than the desired. The z response is highly accurate and not delayed. This case represents the most extreme test of controller performance. In medical applications, i.e. a robot

holding a camera, the following tracking performance specifications are generally accepted: maximum position error of 5mm, and a transient time short about [1.5, 8] seconds in the best/worst case, warranting always a robust stability for safety reasons. Besides, in all position responses the control signal is inside the permissible range.

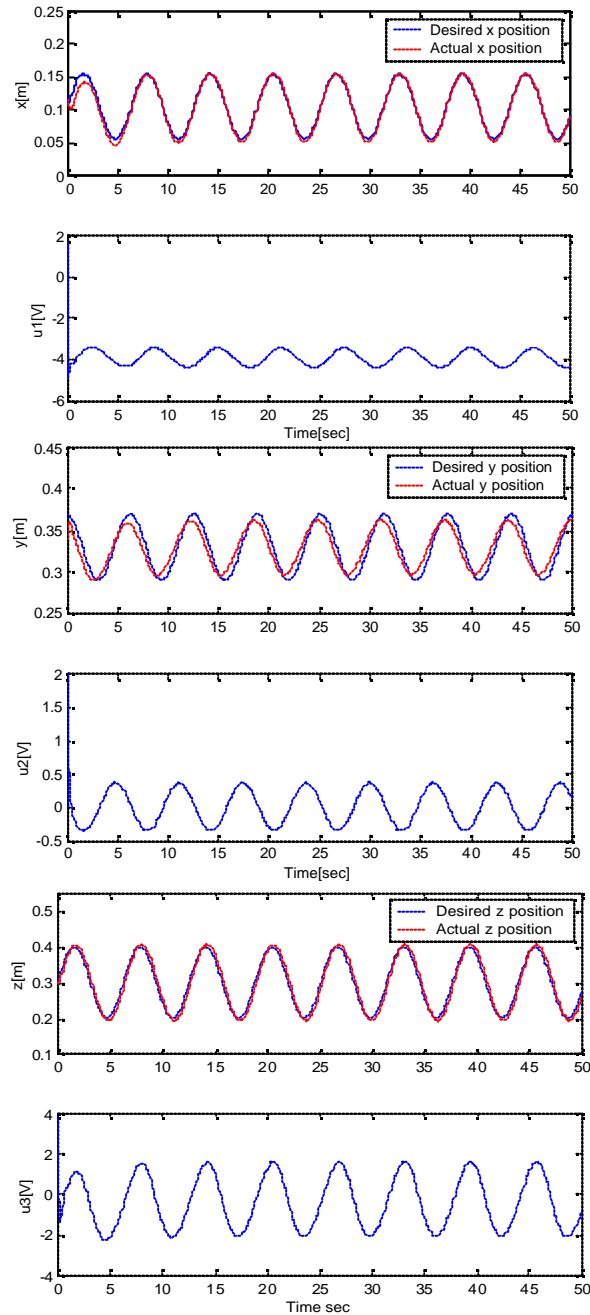

Fig. 9. Tracking response.

5. CONCLUSIONS

In this article a robust control has been designed, overcoming the uncertainties inherent in robotics systems. It has been implemented in a laparoscopic robot and, after simulating the instrument movements, the robot tracks the desired position with a small error, time requirements and stability. Many

study cases were carried out in order to test the robot in all the situations, achieving good results.

REFERENCES

- Amat, J. (2001). *Design and Construction of a Retractable Robot Arm*, Spanish Patent, 2001.
- Bhattacharyya, S.P., H. Chapellat and L.H. Keel (1995). *Robust Control: The Parametric Approach*, Prentice-Hall.
- Berghuis H. and H. Nijmeijer (1994). Robust control of robots via linear estimated state feedback, *IEEE Trans. Automatic Control*, 39 (10), pp. 2159-2162.
- Craig, J.J., P. Hsu and S. S. Sartry (1987). Adaptive control of robot manipulator, *Int. Journal of Robotic Research*, 6, pp.16-28.
- Datta, A., M. Ho and S.P. Bhattacharyya (2000). *Structure and synthesis of PID controllers*, London, Springer
- Dot, P. and D. Pujol (2004). *Robot control in laparoscopic surgical applications*, Internal Report ESAII-RT-04-14, Technical Univ. of Catalonia, <http://webesaii.upc.es>.
- Egeland, O. and J.-M. Godhavn (1994). A note on Lyapunov stability for adaptive robot control, *IEEE Trans. on Automatic Control*, 39 (8), pp.1671-1673.
- Kang, C.G. and H.S. Kwak (1998). "Motion control of a robotic manipulator using Fuzzy Logic in Cartesian space", *J. of Fuzzy Logic and Intelligent Systems*, 8(1), pp. 73-77.
- Koo, K.-M. and J.-H.Kim (1994). Robust control of robot manipulators with parametric uncertainty, *IEEE Trans. on Automatic Control*, 39 (6), pp.1230-1233.
- Krupa, A. *et al.* (2003). "Autonomous 3-D positioning of surgical instruments in robotized laparoscopic surgery using visual servoing", *IEEE Trans. On Robotics and Automation*, 19(5), pp. 842-853.
- Ho, M.-T. (2003). Synthesis of H_{∞} PID controllers: A parametric approach, *Automatica*, 39 (6), pp. 1069-1075.
- Richardson, R., M. Brown, B. Bhakta and M. Levesley (2004, article in press). "Impedance control for pneumatic robot-based around pole-placement, joint space controllers", *Control Engineering Practice*.
- Shamma, J. (1995). "Linealization and Gain Scheduling", Chapter 20, *The Control Handbook*, CRC Press LLC.
- Skogestad, S. and I. Postlethwaite (1997). *Multivariable Feedback Control (Analysis and Design)*, Wiley Ed.