

# APPLICATION OF COMBINED STEERING AND INDIVIDUAL WHEEL BRAKING ACTUATED YAW STABILITY CONTROL TO A REALISTIC VEHICLE MODEL

**Eyüp Serdar Öztürk, Levent Güvenç, Tevfik Yiğit and Bilin Aksun Güvenç**

*Automotive Controls and Mechatronics Research Center  
Department of Mechanical Engineering  
İstanbul Technical University  
Gümüşsuyu, Taksim, TR-34437, İstanbul, Turkey  
Fax: +90 212 245 07 95, E-mail: guvencl@itu.edu.tr*

**Abstract:** Yaw stability control is an important aspect of road vehicle active safety and comfort systems. Yaw stability control can be based on steering or individual wheel braking as the means of actuation for generating the required corrective yaw moments. This paper uses a model regulator based yaw stability controller that combines and coordinates steering and individual wheel braking for improved performance. The key contribution of the paper is the application of this combined actuation controller to a realistic road vehicle model created in a commonly used multi-body dynamics simulation program. The performance achieved by the proposed controller is demonstrated through several simulations. *Copyright © 2004 IFAC*

**Keywords:** Automotive control, yaw stability control, steering control, differential braking, model regulator.

## 1. INTRODUCTION

Road vehicle safety systems can be broadly classified as passive and active safety systems. Passive safety systems include seat belts, air bags and additional structural members. The objective of passive safety systems is to reduce damage to the driver and passengers of a road vehicle in the event of an accident. Active safety systems, on the other hand, help prevent an accident from happening in the first place by trying to keep the vehicle from exhibiting some undesired motions like wheel lock-up, loss of traction or excessive yaw or roll motion that may eventually result in loss of control of the vehicle's dynamic behavior by the driver. Active safety systems, thus, take control away from the driver temporarily, until the undesired vehicle dynamic behavior is corrected. Loss of yaw stability of a road vehicle may result from unexpected yaw disturbances like side wind force, tire pressure loss or  $\mu$ -split braking due to unilaterally different road pavements such as icy, wet or dry pavement. The problem with side wind is due to the consequent panic situation of the driver due in particular to the auditory impression. An average driver may exhibit panic reaction and control authority failure, and may not be able to

generate adequate steering, braking/throttle commands in such panic situations. Road vehicle yaw stability control systems compensate for the driver's inadequacy during panic situations and generate the necessary corrective yaw moments through steering or braking control inputs. Such yaw stability control systems are called Electronic Stability Program (ESP).

The two primary corrective yaw moment generating methods of actuation for ESP systems are compensation using steering commands or using individual wheel braking. Most of the commercially available ESP systems use individual wheel braking as it is more easily accomplished through already existing ABS hardware (see for ex. van Zanten et al, 1995). Steering actuation is the second method of generating corrective yaw moments. Steering actuation can be in the form of a steer-by-wire system or through active steering. In active steering, the mechanical steering linkage is complemented by an extra steering motor which provides extra steering moment to the system. This is a fail safe approach as the mechanical steering system is in place in case of failure of the electric motor. Active steering can be used for implementing power steering, velocity

dependent steering ratio or a yaw stability control system. The disadvantage in the case of a yaw stability control system is that the steering wheel will also move as the stability controller commands corrective steering signals. This is not a very good man-machine interface as the driver will definitely feel the unpleasant loss of his/her control of the vehicle when the yaw stability controller becomes active. A second disadvantage will be a slight loss of responsiveness as the whole steering linkage including the steering wheel has to be moved by the electric motor used for control. Active steering has been available in some cars for a while and it is reported that recent active steering systems have taken care of the first disadvantage mentioned above. In contrast, steer-by-wire systems offer more flexibility for yaw stability controller implementation as the full steering command is available to the controller. Steer-by-wire systems possess only electrical connections between the steering wheel and the steering actuator. This offers great flexibility and solves several problems at the expense of not having a mechanical backup system. Steer-by-wire systems are also available commercially. This technology enables easy implementation of steering based ESP systems (see for example Ackermann et al, 2002; Aksun Güvenç and Güvenç, 2002a) and is therefore concentrated upon as the steering actuation method in this paper.

The biggest overall gain is achieved by combining both steering and braking actuation for more corrective yaw moment when necessary. This methodology is similar to what drivers actually do during their panic reaction. The simultaneous use mentioned has to be performed in a coordinated manner. Combined and coordinated use also allows the control system to switch between actuation methods in the event of an actuator malfunction.

The previous work of some of the authors (Aksun Güvenç and Güvenç, 2002a, 2002b) has resulted in a very useful robust steering based ESP system using a modified model regulator. Realistic simulations and actual road tests of this modified model regulator approach have been successful. Work on an individual wheel braking type implementation of this proposed control law have been conducted by the same authors (Aksun Güvenç and Güvenç, 2002c; Aksun Güvenç et al., 2003a). Previous work on coordinated use of both means of actuation has been presented in Aksun Güvenç et al (2003b, 2004). The aims of the present paper are to present this combined actuation ESP controller in a unified framework that allows its use in a steering only, braking only or combined actuation setting and to demonstrate its usefulness on a realistic, high-fidelity vehicle model, in contrast to the simple, lower order models used in previous work. The modified model regulator is used as the underlying control technique.

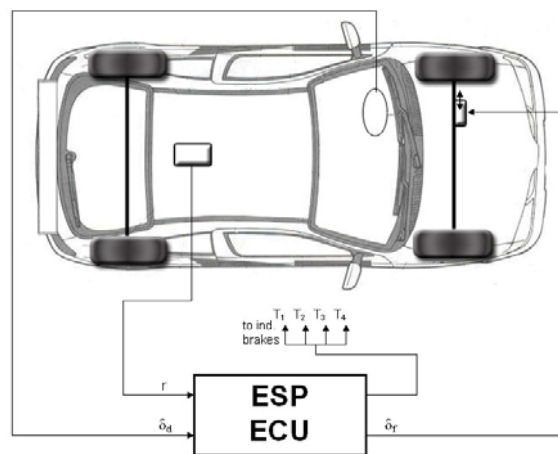

Fig. 1. Combined actuation ESP system architecture

The organization of the rest of the paper is as follows. The model regulator based combined steering/braking controller mentioned above is presented in Section 2. Section 3 is on the Adams<sup>®</sup>/Car vehicle model used. Section 4 presents the combined controller and possible strategies. Simulation results are given in Section 5. Finally, the paper ends in Section 6 with conclusions.

## 2. MODEL REGULATOR BASED COMBINED STEERING/BRAKING CONTROL

The architecture of the proposed combined actuation ESP system is illustrated in Figure 1. The ESP controller ECU receives driver steering command and vehicle yaw rate from installed sensors. Driver brake command or brake system pressure and steer-by-wire actuator position should also be input to this ECU along with some other signals but these will not be part of the discussion in this paper. The rest of this section will be on the control architecture used.

The model regulator (also called the disturbance observer) is a special version of a two degree of freedom control architecture used in motion control tasks. It has been modified and successfully applied to yaw stability control (see Aksun Güvenç and Güvenç 2002a, 2002b for ex.). The model regulator based steering/braking controller that is proposed here is shown in Figure 2. The reader is referred to Güvenç and Srinivasan (1994), Ohnishi (1987) and Umeno and Hori (1991) for more detailed information on the model regulator. The block diagram of Figure 2 has two separate paths for steering actuation and for braking actuation. The braking actuation has a switch as one wheel on either the left or right hand side of the vehicle needs to be used to create a counterclockwise or clockwise corrective yaw moment, respectively.

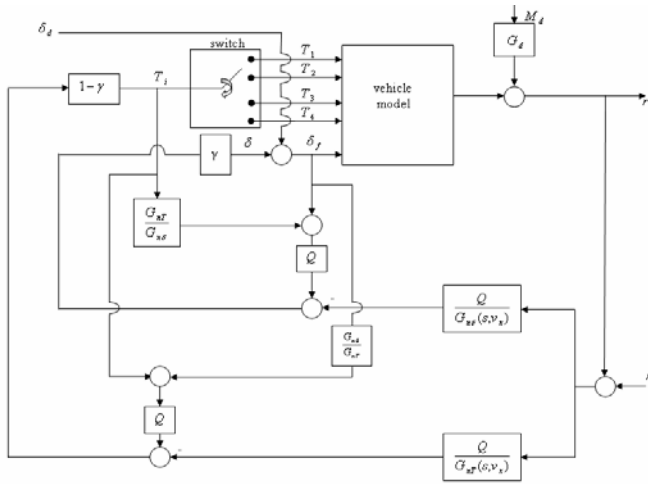

Fig. 2. Combined steering/braking model regulator.

The linearized double track model can be expressed as

$$r = G_T T_i + G_\delta \delta_f + G_d M_d \quad (1)$$

where  $G_T$  and  $G_\delta$  are the individual braking to yaw rate and steering input to yaw rate transfer functions.  $G_d$  is the disturbance input transfer function to yaw rate.  $T_i$  with  $i=1,2,3,4$  represents the individual wheel brake input being applied. Equation (1) can be expressed as

$$r = G_{nT}(1 + \Delta_T)T_i + G_{n\delta}(1 + \Delta)\delta_f + G_d M_d \quad (2)$$

where  $G_{nT}$  and  $G_{n\delta}$  are the desired braking and steering command functions, respectively.  $\Delta_T$  and  $\Delta$  are the multiplicative uncertainties in the knowledge of  $G_{nT}$  and  $G_{n\delta}$ . (2) can be re-expressed as

$$r = G_{nT}T_i + G_{n\delta}\delta_f + e \quad (3)$$

where the extended uncertainty  $e$  is defined as

$$e = G_{nT}\Delta_T T_i + G_{n\delta}\Delta\delta_f + G_d M_d \quad (4)$$

or using Equation (3) as

$$e = r - G_{nT}T_i - G_{n\delta}\delta_f \quad (5)$$

The aim of the combined model regulator controller is to achieve

$$r = G_{nT}T_{id} + G_{n\delta}\delta_d \quad (6)$$

where  $T_{id}$  and  $\delta_d$  represent the driver individual wheel braking input and the driver steering wheel input, respectively.  $T_{id}=0$ , as individual wheel braking action is not available as a driver command. However,  $T_{id}$  will be kept in place in the development of the combined model regulator control laws to make the development easier to follow. It will be set to zero at the end of the development.

Rewrite (3) as

$$r = G_{nT}T_{id} + G_{n\delta}\delta_d + G_{nT}(T_i - T_{id}) + G_{n\delta}(\delta_f - \delta_d) + e \quad (7)$$

The control laws

$$\begin{aligned} \delta_f &= \delta_d - \gamma \frac{e}{G_{n\delta}} \\ T_i &= T_{id} - (1 - \gamma) \frac{e}{G_{nT}} \end{aligned} \quad (8)$$

result in the achievement of aim (6) when substituted in the plant model (7). Substituting for  $e$  from (5) into (8), applying the tunable filter  $Q$  to the feedback signals and noting that  $r+n$  (where  $n$  is yaw rate sensor noise) and not  $r$  by itself is available for feedback,

$$\delta_f = \delta_d - \gamma Q \left[ \frac{1}{G_{n\delta}}(r+n) - \frac{G_{nT}}{G_{n\delta}}T_i - \delta_f \right] \quad (9)$$

$$T_i = T_{id} - (1 - \gamma) Q \left[ \frac{1}{G_{nT}}(r+n) - T_i - \frac{G_{n\delta}}{G_{nT}}\delta_f \right]$$

are obtained as the control laws constituting the combined steering/braking model regulator. The implementation of the control laws in (9) is shown in the block diagram of Figure 2.  $0 \leq \gamma \leq 1$  is a control actuation proportioning parameter.

Noting the definition of the extended disturbance in (5), equation (9) can also be written as

$$\delta_f = \delta_d - \gamma \frac{Q}{G_{n\delta}}(e+n) \quad (10)$$

$$T_i = T_{id} - (1 - \gamma) \frac{Q}{G_{nT}}(e+n)$$

Substitution of equations (10) for the control law into the dynamics equation (7) and some manipulations result in

$$r = G_{nT}T_{id} + G_{n\delta}\delta_d + (1 - Q)e - Qn \quad (11)$$

Equation (6) is the desired input to output relationship while equation (11) is the one that is achieved in practice.

Since the desired goal is to obtain  $r=G_{n\delta}\delta_d$  (equation 6 with  $T_{id}=0$ ), the goal in compensator design is to choose:

1.  $1-Q=0$  or  $Q=1$  for rejecting the extended disturbance, i.e. for model uncertainty (model regulation) and disturbance rejection (recall equation 4 which defines  $e$ )
2.  $Q=0$  for rejecting sensor noise  $n$ .

These two goals are in conflict with each other. This conflict can only be resolved if  $Q$  is chosen as a low pass filter, satisfying item 1 above at low frequencies and item 2 above at high frequencies. This choice is

adequate as yaw rate sensor noise will occur at high frequencies and yaw moment disturbances like side wind occur at lower frequencies. Model uncertainty occurs at high frequencies but it enters the extended disturbance after being multiplied by low pass filters and is, thus, not very significant at frequencies where significant yaw rate sensor noise occurs.

### 3. VEHICLE MODEL USED

Vehicle dynamics control systems like ESP are first tested on simple lower order models like single track or double track models. This approach has been used in the previous work of the authors (Aksun Güvenç et al; 2003a, 2004). The ultimate test of a vehicle dynamics control system is conducted in road tests using an instrumented vehicle. There are two approaches that fill the gap between these two extremes if road tests are not possible or to perfect the control algorithm as much as possible before expensive road tests. The first approach is the use of human and hardware in the loop simulation. A typical human-in-the-loop simulation setup used by the authors in related other work is shown in Figure 3. The other approach, which is taken in this paper, is to use a realistic higher-order, higher fidelity vehicle model in a simulation study.



Fig. 3. Human-in-the-loop simulation setup

Table 1 SUV model parameters

Parameter	Numerical Value
Mass	1824 kg
Front Suspension	Double wishbone
Rear Suspension	Double wishbone
Front Brakes	Disk Brake
Rear Brakes	Disk Brake
Tires	P225/70R16
Wheelbase	2.66 m
Length	4.50 m
Width	1.79 m
Height	1.65 m
Front Wheel Track	1.482 m
Rear Wheel Track	1.493 m



Fig. 4. SUV model used

An Adams<sup>®</sup>/Car vehicle model is thus used in this paper as the plant being controlled. Adams<sup>®</sup> is a multi-body dynamics solver package and Adams<sup>®</sup>/Car contains templates created for road vehicles. A typical SUV (see Figure 4) model was created in Adams<sup>®</sup>/Car for this purpose. Some of its important model parameters are listed in Table 1.

### 4. COMBINED CONTROLLER AND POSSIBLE STRATEGIES

First, the controller details (see equations 10) will be presented. The desired individual wheel braking to yaw rate transfer function is chosen as

$$G_{nT}(s, v_x) = \frac{K_T}{\tau_{nT}(v_x)s + 1} \quad (12)$$

$\tau_{nT}$  was chosen to be constant in this study and  $v_x$  is the current longitudinal speed. The desired transfer function from steer-by-wire actuator input to yaw rate is chosen as

$$G_{n\delta}(s, v_x) = \frac{K_{n\delta}(v_x)}{\tau_{n\delta}(v_x)s + 1} \quad (13)$$

where

$$K_n(v_x) = G_\delta(s, v_x) \Big|_{s=0} \quad (14)$$

is the static gain at the current longitudinal speed  $v_x$  of the vehicle model with ideal dry road-tire condition ( $\mu=1$  for all four tires). This gain is approximated by the corresponding single track model velocity. With choices (12) - (14), the combined model regulator becomes a velocity scheduled controller. The Q filter in (9) is chosen as

$$Q = \frac{1}{\tau_Q s + 1} \quad (15)$$

Note that other more complicated choices of the desired steering and braking transfer functions and the Q filter are possible.

The rest of this section is on some possible strategies for the choice of the control actuation proportioning parameter  $\gamma$ . First of all, the proposed controller possesses a seamless passage between individual braking control and steering control in a unified architecture through extreme values of the parameter  $\gamma$ .

- $\gamma=0$  corresponds to individual wheel braking control only. This is standard ESP.
- $\gamma=1$  corresponds to steering control only.
- $\gamma>0$  and  $\gamma\ll 1$  is used for complementing individual wheel braking control with a small amount of steering control in order not to saturate the braking actuator used.
- $\gamma<1$  and  $\gamma\gg 0$  is used for complementing steering control with a small amount of individual wheel braking in order not to saturate the steering controller.
- Other values of  $0<\gamma<1$  can be selected based on the Kamm circle of Figure 5 to maximize the available lateral/longitudinal force combination for achieving the largest corrective yaw moment. At point *a* in Figure 5, for example, a smaller  $\gamma$  value like 0.3 should be chosen as compared to point *b* where a larger  $\gamma$  value like 0.7 should be chosen.

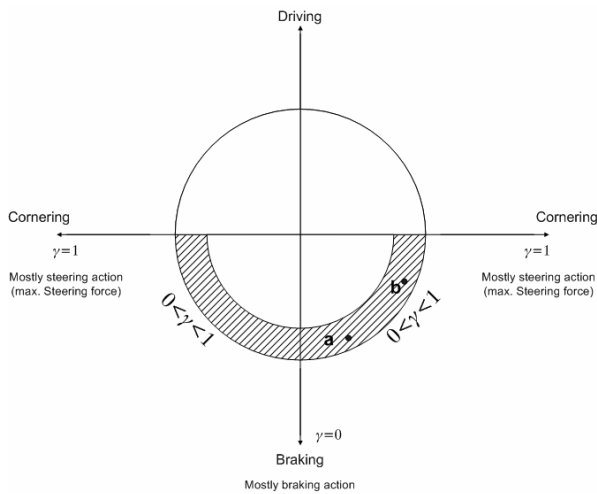

Fig. 5. Steering/braking combinations on the Kamm diagram

## 5. SIMULATION STUDY

In the simulations, the controller in Section 2 is implemented in Matlab<sup>®</sup>/Simulink<sup>®</sup> while the vehicle model is implemented in Adams<sup>®</sup>/Car. Co-simulation of both programs was used to obtain the simulation results presented here.

The first simulation result to be presented is a double lane change maneuver on a low friction ( $\mu=0.6$ ) surface. The aim is to make sure that the actual vehicle yaw rate response follows that of the nominal model in Equation (6) regardless of the change in friction coefficient. The desired, controlled (with  $\gamma=0.7$ ) and uncontrolled (only pre-programmed driver

steering input) situation yaw rate responses are shown in Figure 6. Note that the uncontrolled yaw rate response is quite different than the desired one. The controlled and desired responses are sufficiently close to each other. Even though, there is a noticeable lag between these responses due to delays in the actual system and the actuator dynamics, the results achieved are quite satisfactory. The steering and individual brake actuation levels are shown in Figure 7. Note that depending on the sense of the desired corrective yaw moment, either the left or right brakes are applied to help the steering actuator. This is a model regulation task which has been successfully performed by the combined controller.

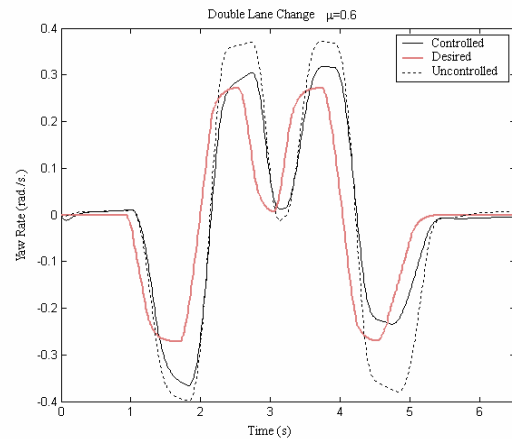

Figure 6 Yaw rates in double lane change maneuver

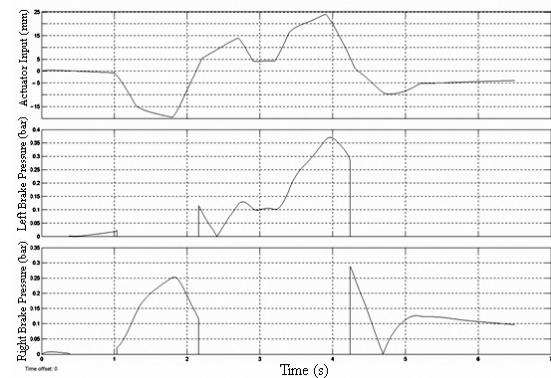

Figure 7 Control actuation levels in double lane change maneuver

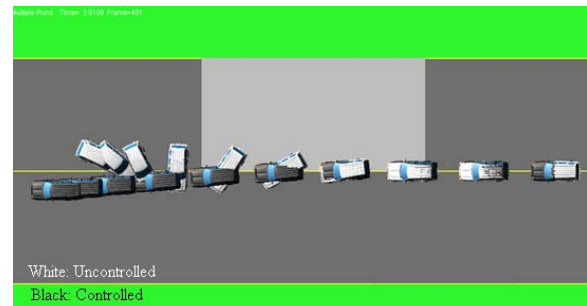

Figure 8  $\mu$ -split maneuver

The second simulation maneuver that will be discussed here is  $\mu$ -split braking. In this extremely demanding maneuver, the vehicle enters a road surface with unilaterally different friction coefficients ( $\mu_{\text{right}}=0.9$ ,  $\mu_{\text{left}}=0.3$ ). The brakes are fully applied when this surface is entered. The result is a very large yaw

moment that makes the car spin and lose its lateral stability. This situation is exhibited by the uncontrolled vehicle in Figure 8. The combined controller with  $\gamma=0.3$  maintains the yaw stability as seen in the response of the controlled vehicle in Figure 8.

The control actuation levels in Figure 9 show the amount of steering action that is used to aid the braking actuation. This is a disturbance rejection task which has been successfully performed by the combined controller. A comparison of the yaw rates achieved in the controlled and uncontrolled cases shown in Figure 10 illustrate this disturbance rejection quite clearly.

The large number of simulations at different conditions including side wind disturbance responses are not presented here due to reasons of length.

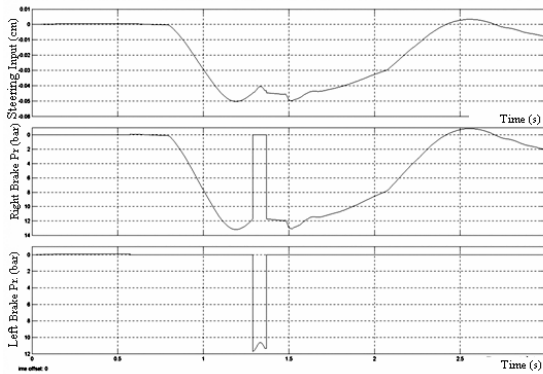

Figure 9 Control actuation levels in  $\mu$ -split maneuver

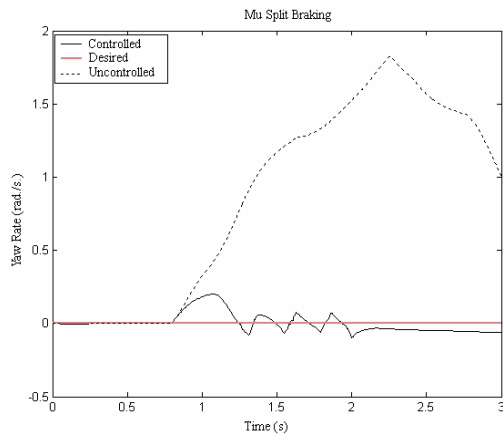

Figure 10 Yaw rates in  $\mu$ -split maneuver

## 6. CONCLUSIONS

A combined steering/braking model regulator was presented here for coordinating and appropriate proportioning of steering and individual wheel braking actuator efforts. The aim was to achieve better performance through a combined actuation controller. The method was demonstrated by realistic simulations based on a higher order, high fidelity vehicle model. Work on control actuation proportioning strategies is in progress..

## ACKNOWLEDGMENT

The authors would like to acknowledge the support of the Turkish National Research Council Tübitak under grant number MISAG-200.

## REFERENCES

- Ackermann, J., Blue, P., Bunte, T., Güvenç, L., Kaesbauer, D., Kordt, M., Muhler, M. and Odenthal, D. (2002). *Robust Control, the Parameter Space Approach*. Springer Verlag, London.
- Aksun Güvenç, B. and Güvenç, L. (2002a). Robust Steer-by-wire Control based on the Model Regulator. *IEEE Conference on Control Applications*, Glasgow, pp. 435-440.
- Aksun Güvenç, B. and Güvenç, L. (2002b). The Limited Integrator Model Regulator and its Use in Vehicle Steering Control. *Turkish Journal of Engineering and Environmental Sciences*, pp. 473-482.
- Aksun Güvenç and B., Güvenç, L. (2002c). Robust Model Regulator Based Vehicle Dynamics Control Using Individual Wheel Braking. *ASME ESDA 2002, the 6<sup>th</sup> Biennial Conference on Engineering Systems Design and Analysis*, İstanbul.
- Aksun Güvenç, B., Güvenç, L., Öztürk, E.S. and Yiğit, T. (2003a). Model Regulator Based Individual Wheel Braking Control. *IEEE Conference on Control Applications*, İstanbul.
- Aksun Güvenç, B., Acarman, T. and Güvenç, L. (2003b). Coordination of Steering and Individual Wheel Braking Actuated Vehicle Yaw Stability Control. *IV2003, IEEE Intelligent Vehicles Symposium*, Columbus, Ohio.
- Aksun Güvenç, B., Güvenç, L., Yiğit, T. and Öztürk, E.S. (2004). Coordination Strategies for Combined Steering and Individual Wheel Braking Actuated Vehicle Yaw Stability Control. *1<sup>st</sup> IFAC Symposium on Advances in Automotive Control*, Salerno
- Dugoff, H., Fancher, P. and Segel, L. (1970). An analysis of tire traction properties and their influence on vehicle dynamic performance. *SAE paper no. 700377*.
- Güvenç, L. and Srinivasan, K. (1994). Friction compensation and evaluation for a force control application. *J. of Mechanical Systems and Signal Processing*, vol. 8, no. 6, pp. 623-638.
- Horiuchi, S., Okada, K. and Nohtomi, S. (2000). Effects of integrated control of active four wheel steering and individual wheel torque on vehicle handling and stability – A comparison of alternative control strategies. *The Dynamics of Vehicles on Roads and on Tracks, Supplement to Vehicle System Dynamics*, Vol. 33, R. Fröhling (Editor).
- Koibuchi, K., Yamamoto, M., Fukada, Y. and Inagaki, S. (1996). Vehicle Stability Control in Limit Cornering by Active Brake," *SAE paper No. 960487*.
- Ohnishi, K. (1987). A new servo method in mechatronics. *Trans. Japanese Soc. Elect. Eng.*, vol. 107-D, pp. 83-86.
- Umeno, T. and Hori, Y. (1991). Robust speed control of dc servomotors using modern two degrees-of-freedom controller design. *IEEE Transactions on Industrial Electronics*, vol 38, no. 5, pp. 363-368.
- van Zanten, A.T., Erhardt, R. and Pfaff, G. (1995). VDC, the vehicle dynamics control system of Bosch. *SAE paper No. 950759*