

FAULT DIAGNOSIS EXPERT SYSTEM USING NEURAL NETWORKS FOR ROASTING PROCESS

YAN Ai-jun *, WU Feng-hua, CHAI Tian-you

Research Center of Automation, Northeastern University, Shenyang, P. R. China, 110004

Abstract: An intelligent fault diagnosis system integrating neural networks, expert system and case-based reasoning technology is established for the roasting process of shaft furnace in hematite ores processing of China. The structure, function, and realization methods of the proposed system are presented. The proposed system has been successfully applied to the roasting process of shaft furnace in the biggest hematite ores processing factory of China. The industrial application shows the effectiveness of proposed system for the fault diagnosis of the roasting process of shaft furnace and its potential future in the complex industrial process. *Copyright © 2005 IFAC*

Key words: Shaft Furnace; Fault Diagnosis; Neural Networks; Expert Systems; Case-Based Reasoning

1. INTRODUCTION

The iron and steel industry in China has made great progress and has become one of the largest producers in the world. Minerals processing is an important basis of the iron and steel industry. Despite the abundant mineral resources of iron ores in China, conventional minerals processing is difficult due to lower tenor of minerals, which usually stands at about 33 percent. In order to improving the concentrating effect, the way of high temperature deoxidizing magnetization roasting by shaft furnace is used. In this way, weak magnetism mineral may turn to strong magnetism mineral which can be concentrated by magnetic dressing. Thereupon, roasting process of shaft furnace is important to the production indices of metal recovery rate and tenor of finished ores. In other words, the key work of enhancing the metal recovery rate and tenor of finished ores during minerals processing is manipulating the roasting process of shaft furnace correctly.

The automation of the roasting process of shaft furnace should deal with complex problems about many aspects and many levels of which the absolutely necessary part is fault diagnosis. Once the fault occurs, production will be impacted terribly, the work state of the shaft furnace will turn to instable or even, suspended, which may lead to uncontrollability of roasting process.

The roasting process of shaft furnace is characterized by slow time varying characteristics, distributed parameters, non-linearity and large time delays which makes it very difficult to establish accurate mathematical modeling of the process. Because fault diagnosis is an integrated technology, traditional fault diagnosis methods based on linear process models are unable to obtain satisfactory results. In recent years, artificial intelligence (AI) technology has been applied to the area of fault diagnosis (Yu, *et al.*, 1999; Wu, *et al.*, 2002; Awadallah and Morcos, 2003; Cai, 2003) such as intelligent process monitoring, intelligent control of self-motion machining; intelligent fault inspect and diagnosis of production, intelligent control of aero craft aviating and landing and intelligent control of medical treatment, etc. But in roasting process of shaft furnace there isn't such

* Corresponding author. Fax: +86-24-23895647.
E-mail address: ajy2004@126.com

instance reported.

Considering the limitation of traditional expert system in the area of fault diagnosis, this paper developed an intelligent fault diagnosis system for the roasting process of shaft furnace, combining the advantages of neural networks, expert systems and case-based reasoning (CBR). The structure, function and realization of the proposed system are presented. This system has been successfully applied to the roasting process of shaft furnace in the biggest hematite ores processing factory of China. It has been found to provide many benefits to the factory and has extending and application value.

2. DESCRIPTION OF ROASTING PROCESS OF A SHAFT FURNACE

Weak magnetic iron ores are reduced to strong magnetic ores under high temperatures in a so called "ANSHAN" shaft furnace in a minerals processing factory of a certain steel company in China. This process is commonly known as roasting (Zhang and Chai, 2000). In the factory there are 22 such shaft furnaces which were built in 1926. The roasting process of shaft furnace includes: infilling, preheating, heating, reducing, cooling and moving out as shown in Fig.1.

There are six common faults in the shaft furnace roasting process:

- 1) The iron ores are melted and stick to the firebricks in the furnace (*MS*).
- 2) Iron ores inside the furnace explode (*GE*).
- 3) Ore size is not big enough, as a result they come down to the bottom of the furnace before the reactions are completed (*DR*).
- 4) Iron ores stick inside the furnace so that further entry of ores is impossible (*SE*).
- 5) Flames reach out of the top of the furnace (*FO*).
- 6) Backfire: fire enters the gas pipes (*BF*).

When shaft furnace is working, complicated physical chemistry and thermodynamics processes occur inside, in addition, the shaft furnace and its appendixes have been chronically consumed, making

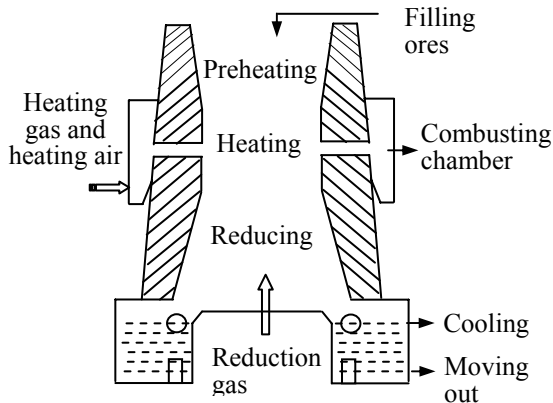

Fig. 1. The process of shaft furnace roasting

their parameters being varied slowly, so the roasting process of shaft furnace is quite complex. For a long time, the shaft furnace has been controlled mainly by hand with operators making control decisions based on experience. Once improper operation happens, production process and operators' personal safety will be disserved and enormous economic loss will be produced. A complete fault diagnosis system can analyze the state of the roasting process of shaft furnace in time and therefore guide the operator in preventing such failures or accidents.

3. THE INTELLIGENT FAULT DIAGNOSIS SYSTEM OF THE ROASTING PROCESS OF SHAFT FURNACE

In the complex industrial roasting process of shaft furnace, the fault diagnosis system is required to correctly identify all fault types that could possibly affect production and to prevent false reports or report failures to the maximum extent. The system should be able to assess the severity of any current failures and provide operators with correct instructions. The system enables users to make sound decisions by predicting the future trends of the state of operation. Because roasting process of shaft furnace is a changeable and dynamic process, to increase credit of conclusion, users are always needing the fault diagnosis system to give reasonable explanation by an easy understanding language. That is to say, the fault diagnosis system is needed to have strong abilities of knowledge expressing and explanation.

3.1. Structure and function

In the roasting process of shaft furnace, many reasons can lead to faults. One kind of them is the appendixes of shaft furnace have broken down. For example, the suspending of exhaust fan will decrease the negative press inside and lead to *FO*, even, *GE*. Such faults can be found by experts' inferences through examining the parameters and analyzing their varying trends. The other kind of faults which is brought out due to complex reactions, granules movement and some exterior effects may be diagnosed through experiments combining to production indices.

The structure of the intelligent fault diagnosis expert system based on neural networks is shown in Fig. 2. The main functions of the modules are:

Fault prediction subsystem: fulfilling the intelligence deducing from basic product parameters to faults forecast using explicit base and corresponding reasoner of expert system, Concretely is, deducing the fault symptoms $FauP$ through negative pressure P_{LN} , temperature of preheating T_{YR} , temperature of combustion chamber T_{RS} , flow of

heating gas L_{JR} , moving out time t_{BC} , the state of heat value meter L_{HT} and the moving trends of some of them. The experience knowledge includes the threshold of above parameters and their comparatively varying trends.

Roasting quality supervision subsystem: Providing the fault diagnosis system with the production quantity index of magnetic tube recovery rate (MTRR) $\varepsilon_{YB}(k)$ as reference. It consists of three modules:

- 1) MTRR prediction module: predicting MTRR $\varepsilon_{YB}(k)$ with temperature of combustion chamber T_{RS} , flow of reducing gas L_{HY} and moving out time t_{BC} .
- 2) SPC: performing the human perception function to process the assayed values of technical indices.
- 3) NN training algorithm: training the MTRR prediction module using the result of the SPC and the NN training.

Fault analysis subsystem: Based on the fault prediction $FauP$ of expert system, production quantity index $\varepsilon_{YB}(k)$ decided by MTRR prediction module and correlation knowledge of roasting process of shaft furnace including boundary condition B such as the sort of ores, heating gas pressure P_{JR} , flow of heating air L_{KQ} , flow of reducing gas L_{HY} , negative pressure P_{LN} , etc., the kind of faults and their solutions $FauS$ with the help of CBR technology are obtained.

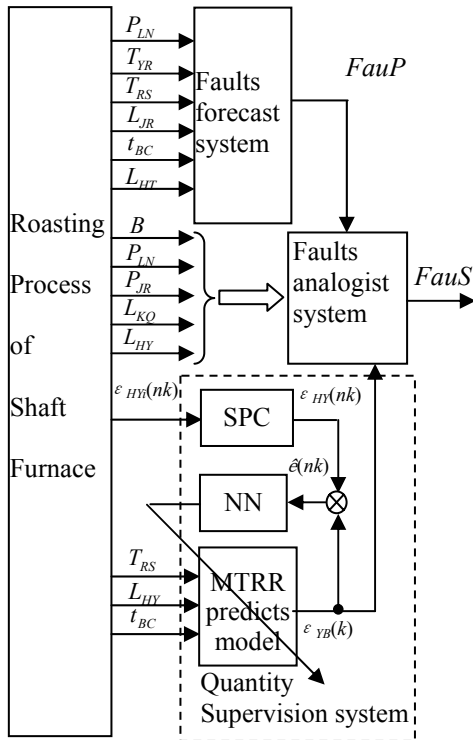

Fig. 2. The structure of the intelligent fault diagnosis expert system

3.2. The realizing methods of the fault diagnosis

Expert system for fault diagnosis The knowledge storage can obtain knowledge or data directly from the process operators or indirectly from expert knowledge, i.e. the threshold of negative pressure P_{LN} , temperature of preheating T_{YR} , temperature of combustion chamber T_{RS} , flow of heating gas L_{JR} , moving out time t_{BC} etc. and their relations. This knowledge indicates the requirements of several primary faults that could possibly occur in the roasting process. In order to make knowledge understandable, accessible, extensible, compatible, correct, and simple, production rules were selected to represent knowledge. That is the following format (Simon, *et al.*, 1997):

IF < premise > THEN < conclusion >

The premise includes producing parameters in roasting process of shaft furnace and other information affecting the production, while conclusion was the conceivable faults or their symptoms. For example, when the premise is “negative pressure less than its threshold”, the conclusion may be “GE might happen”.

The roasting quality supervision subsystem based on NN The above faults must bring serious influence to the quantity of roasting process of shaft furnace which is scaled by MTRR. But the index of MTRR isn't measured online. It is only obtained during nonscheduled test from the production of roasting process. Therefore, developing the MTRR prediction model make it possible to supervising the roasting quantity online.

Prediction model of the MTRR module adopted NN training algorithm. The simplified structure is shown in Fig. 3.

Statistical process control (SPC) The operator uses assayed values of MTRR ε to evaluate technical indices. SPC is used to process the assayed values:

$$\varepsilon(nk) = \sum_{i=1}^K \varepsilon_{HY}(nk) / K \quad (1)$$

Where, K is the number of samples.

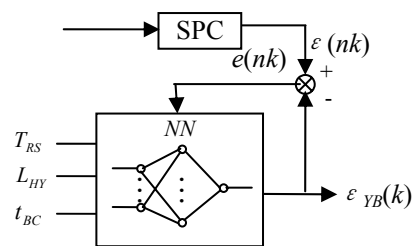

Fig. 3. the neural network prediction model of MTRR

NN training algorithm (Chai, et al., 1999) The inputs of *NN* are temperature of combustion chamber T_{RS} , flow of reducing gas L_{HY} , moving out time t_{BC} while the output of it is magnetic tube recovery rate $\varepsilon_{YB}(k)$. The supervisor signal of training algorithm is $\hat{e} = \varepsilon(nk) - \varepsilon_{YB}(k)$. Learning algorithm of the RBF network model adopts the structure of 3-11-1.

Firstly the input and output variables are normalized to 0~1 as formula (2):

$$\{(T_{RS}, L_{HY}, t_{BC} | \varepsilon_{YB})\} \rightarrow \{(x_1, x_2, x_3 | b)\} \quad (2)$$

Then original values of the weights of ω , the centre of t and the width of the implicated function of Σ^{-1} are given by many simulations and experimentations as $w_i(0)=0.09$, $t_i(0)=[0.3,0.3,0.5]$, $\Sigma_i^{-1}=[0.5, 0.5, 0.5]$, ($i=1, 2, \dots, m$, m is the node number of the hidden layer).

Next, the model uses supervisor signal to eliminate prediction error by adapting ω , t , Σ^{-1} as formula (3) - (5), until the precision of solution of error function (6) is met.

$$\omega_i(n+1) = \omega_i(n) - \eta_1 \cdot \sum_{j=1}^N e_j(n) \cdot G(\|x_j - t_i(n)\|) \quad (3)$$

$$t_i(n+1) = t_i(n) - \eta_2 \cdot \omega_i(n) \sum_{j=1}^N e_j(n) \cdot G(\|x_j - t_i(n)\|) \Sigma_i^{-1}(n) [x_j - t_i(n)] \quad (4)$$

$$\Sigma_i^{-1}(n+1) = \Sigma_i^{-1}(n) - \eta_3 \cdot \omega_i(n) \sum_{j=1}^N e_j(n) \cdot G(\|x_j - t_i(n)\|) [x_j - t_i(n)]^T \quad (5)$$

$$E = \frac{1}{2} \sum_{j=1}^N e_j^2 \quad (6)$$

$$e_j = d_j - \sum_{i=1}^m \omega_j G(\|x_j - t_i\|_{c_i})$$

Where, N is the number of training samples and η is the learning rate, $\eta_1=0.6118$, $\eta_2=0.2$, $\eta_3=0.1055$.

Finally, the structure and parameters of *NN* are stored to predict the MTRR.

On the bases of former experience in fault cases of shaft furnace, the oncoming fault cases are stored in computer as database which consists of some case registers. Table 1 described the case structure.

The reasoning process of CBR may reduce to 5 steps (Tan and Chai, 2005): retrieval, reuse, revision, reviewal and retention.

Table 1 Case structure of faults of Shaft furnace

components	Variables	Values
Case description of faults of shaft furnace	Ore sort	x_1
	Roast Degree	x_2
	Ore granularity	x_3
	South moving out	x_4
	North moving out	x_5
	Furnace condition	x_6
	Heating gas pressure	x_7
	Flow of heating air	x_8
	Flow of Reducing gas	x_9
	Negative press	x_{10}
	Fault prediction	x_{11}
	MCTR rate prediction	x_{12}
Case solutions (fault sort)	<i>MS</i>	y_1
	<i>GE</i>	y_2
	<i>DR</i>	y_3
	<i>SE</i>	y_4
	<i>FO</i>	y_5
	<i>BF</i>	y_6

4. INDUSTRIAL EXPERIMENTS

4.1. Introduction of fault diagnosis system

The biggest hematite ore concentrator of China owns 22 shaft furnaces. In the past, the fault diagnoses of them were completely executed by operator with the help of their experience. Once observation is delayed or operation is improperly, faults will occur. Production and operator's personal safety will be influenced seriously and enormous economic losses would be brought. Adopting the proposed method, the intelligent fault diagnosis system is developed as Fig. 4 (one shaft furnace for instance), considering the actual condition. Main instrument signals relating to fault diagnosis are processed and regulated by DCS control system, such as the temperature of combustion chamber T_{RS} measured by thermocouple KT, the temperature of preheating T_{YR} measured by thermal resistance RT, heating gas pressure P_{JR} measured by manometer HT, etc. the intelligent fault diagnosis system accepts the correlation information stemming from DCS control system and in reverse it provides the solutions and hint information to DCS control system. Simultaneously, the solutions serve as the basis for decision-making of optimal setting model (Chai and Guan, 1998) that accepts the operating condition of the furnace and handles questions before producing the optimal setting value of the controlled parameters based on production indices. So the intelligent optimal control system can adapt to outside conditions in real time, and technical

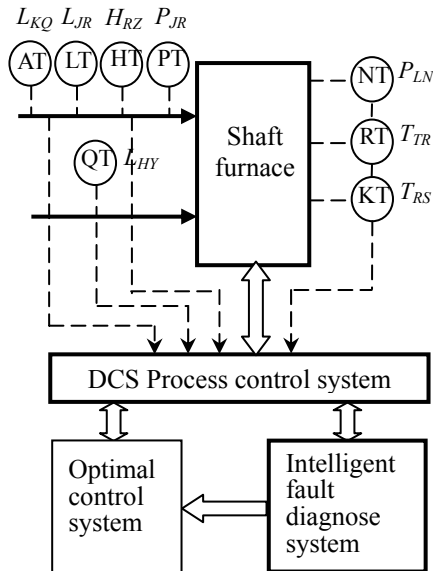

Fig. 4. Intelligent fault diagnosis system for shaft furnace

indices are optimized and production safety is ensured at the maximum degree.

4.2. Experiments and results

As a test, the system proposed is applied to the fault diagnosis task of No. 10 shaft furnace. The trend of flow of heating gas (Fig. 5.) in a certain time showed it is in state of dynamic stabilization, while the corresponding temperature trend of combustion chamber (Fig. 6.) is persistently ascending. By analyzing of expert subsystem, it is considered as the symptom of *MS*.

At the same time, the trend of MTRR (Fig.7.) is presented by roasting quantity supervision subsystem,

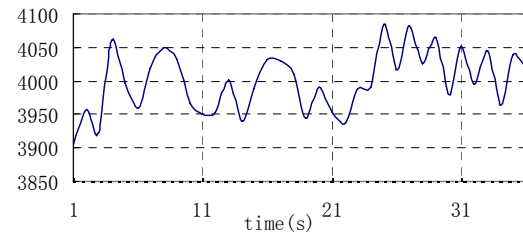

Fig. 5. Trend of flow rate of heating gas

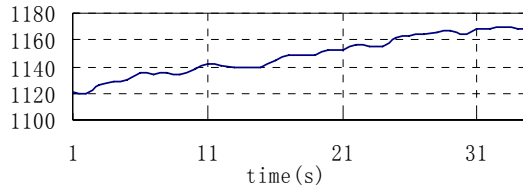

Fig. 6. Trend of temperature of combustion chamber

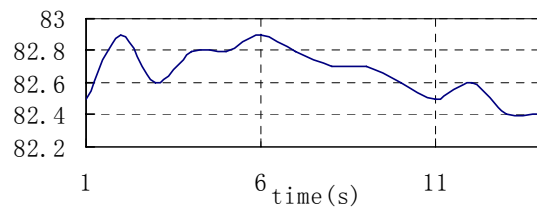

Fig. 7. Trend of MTRR prediction

which shows descending of it.

These intermediate results will be adopted by fault analysis subsystem as bases of final case solutions.

In fault analysis subsystem, we provide the 12 case descriptions with corresponding weight to the case solutions based on the experiments and realities: $\omega_1=0.06$, $\omega_2=0.06$, $\omega_3=0.06$, $\omega_4=0.04$, $\omega_5=0.04$, $\omega_6=0.08$, $\omega_7=0.06$, $\omega_8=0.06$, $\omega_9=0.06$, $\omega_{10}=0.08$, $\omega_{11}=0.2$, $\omega_{12}=0.2$. By the processes of retrieving, reusing, etc., it maintains such diagnosis result and

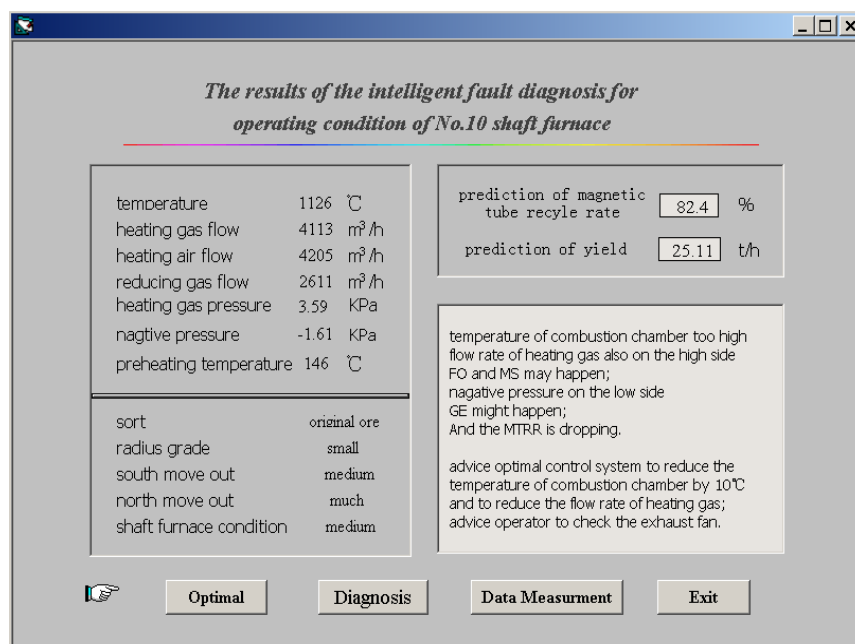

Fig 8. The result interface of intelligent fault diagnosis

suggestion: the temperature of combustion chamber of No. 10 furnace is too high and flow of heating gas is a lot excessive, these may lead to *FO* and *MS*, furthermore. The negative pressure being on the low side might lead to *GE*. At the same time, the prediction of MTRR is decreasing, indicating the condition of the shaft furnace is turning bad. According to the result of the diagnosis and as a basis of adjusting the optimal setting value, the following advices are put forward to the optimal control system to prevent the faults: cutting the setting value of combusting chamber 10°C down and reducing flow of heating gas. In addition, the system clues the operator to check up the exhaust fan. This result is displayed in one of the intelligent fault diagnosis interfaces (Fig. 8.).

Real time operations of the system show that the outputs match the desired results for fault situations, which indicates the promise of the system for fault diagnosis. The accuracy of fault diagnosis stands at about 90% after more than one year's practical operation.

Long time operations of the system show that equipment operation rate is increased by 2.98%, production rate of one furnace is increased from 24.90T/h to 25.62T/h with an increase of 0.72 T/hot strip mill, the magnetic tube recovery rate is increased by 2%. Production indices have remarkably enhanced comparing to the past.

5. CONCLUSIONS

An intelligent fault diagnosis system combining neural networks, expert systems and case-based reasoning is presented in this paper. Its successful application to the biggest minerals processing factory shows: 1) Application of the intelligent fault diagnosis system has led to a significant improvement in production indices for roasting process of shaft furnace. 2) Dealing with diagnosis problems, combining with neural networks and CBR to expert systems is superior to traditional expert systems in terms of accuracy, intelligence, feasibility and robustness.

ACKNOWLEDGMENTS

This work was supported by the Chinese National Hi-Tech Development Program (2004AA412030) and the National Key Basic Research and Development Program of China under Grant 2002CB312201.

REFERENCES

Awadallah, M. A. and Morcos, M. M.. (2003). Application of AI Tools in Fault Diagnosis of Electrical Machines and Drives - An Overview.

IEEE Transactions on Energy Conversion, **18**(2), 245-251.

Cai, Z.. (2003). Recent Advances in Research of Intelligent Control Engineering. *Control Engineer of China*, **1**(1), 1-5, &10.

Chai, T., Guan, S.. (1998). Object-oriented Integrated Control Technology of Complex Industrial Processes, Plenary Lecture. *Proceedings of 5th Symposium on Low Cost Automation*.

Chai, T., Xie, S.. (1999). Endpoint Prediction of Basic Oxygen Furnace Steel Making Based on RBF Neural Network. *The Chinese Journal of Nonferrous Metals*, **9**(4), 868-872.

Simon C. K. Shiu, James N. K. Liu and Daniel S. Yeung.. (1997). Formal Description and Verification of hybrid rule/Frame-Based Expert systems. *Expert systems with applications*, **3**(13), 215-230.

Tan, M. and Chai, T.. (2005). Modelling of the Laminar Cooling Process with Case-Based reasoning. *Control Theory & Applications*, **22**(2).

Wu, M., She, J. H., Nakano, M. and Gui, W.. (2002). Expert Control and Fault Diagnosis of the Leaching Process in Zinc Hydrometallurgy Plant. *Control Engineering Practice*, **10**(4), 433-442.

Yu, D. L., Gomm, J. B. and Williams, D.. (1999). Sensor Fault Diagnosis in a Chemical Process via RBF Neural Networks. *Control Engineering Practice*, **7**(1), 49-55.

Zhang, X. and Chai, Z.. (2000). Development and Production Practice of 100m³ Shaft Furnaces in Jiuquan Steel Co.. *Metal Mine*, (3), 32-33, &40.