

ON-LINE FAULT DIAGNOSIS IN THE LARGE POWER SYSTEM

Gyu-Seok Seo, Young-Sik Baek, Jung-Nyun Kim*¹ and Moo-Ho Han*²

Dept. of Electrical Engineering, Kyungpook National University, Korea

**¹LG Cable Ltd, Korea*

**²Research Institute of Industrial Science & Technology, Korea*

Abstract: Recently, power system is getting larger and more complex. When the complex power system has a problem, it is very difficult even for the experts to find out where the problem is and to make a timely decision by operators. There have been many studies on these problems but the results are not good enough for applying to real power system. Therefore power system operators always had to judge the exact state of power system and had to be preparative for the problems that can occur later. We developed new methods that can be applied to complex power system by dividing the system into small modules. By using 'module', we can combine small modules together to make complex power systems and the knowledge base that is applied to fault diagnosis system. As a result, compared to previously developed diagnosis products, operational time has shortened, and the knowledge base becomes simpler and clearer, which made online usage capable. This system can be used as a complementary measure that helps the operator from making any mistakes. *Copyright © 2005 IFAC*

Keywords: power systems, expert system, modulation, diagnosis, inference engine, knowledge-based systems.

1. INTRODUCTION

Because the power utilities are exposed to outside environments, various kinds of faults can occur due to the natural disasters or other cases. The major concerns of the utilities are maintaining the power supply stable, faults analysis and restoration and protection of the power system. Fault diagnosis of power system is to estimate the position and causes of faulted element. The rapid estimation is very important because the fault can cause wide and drastic spread out of power failure areas. In spite of many efforts to solve these problem, fault diagnosis are mostly depends on the experience of skilled experts in real system.

The electric power system is complicated and the causes of the fault of power system are various and complicated that the protective measure becomes also complicated. When protection devices such as Ry(relay) and CB(circuit breaker) operate rightly, judgment and restorative action of faults are easy.

However, there are many difficulties in correcting faults in case of false operation or no operation of Ry and CB. So far, various expert systems related to fault diagnosis are studied such as Rule based expert system, Frame based expert system and Logic based expert system. These expert systems has limit in applying to real power system due to the huge and complicated knowledge building.

In this paper, new diagnosis algorithm using the module is proposed. OOP(Object Oriented Programming) technique is applied to represent power systems to cope with change of system state. Inference Engine is composed according to the module. In conclusion, this system is actually tested in real power system.

2. FAULT DIAGNOSIS OF POWER SYSTEM

2.1 System configuration

Generally, restorative actions are very simple. However, it will take long time if power system is large and complicated.

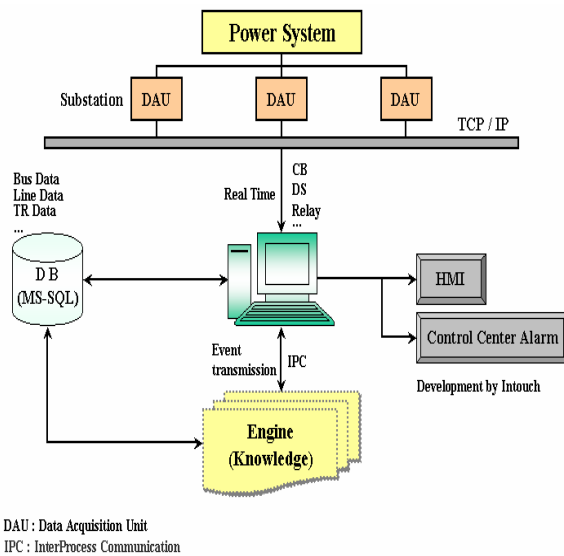

Fig. 1. Configuration of fault diagnosis system

Although fault situation is simple, there can be a possibility of mistakes in inspecting fault. For this reason, it is necessary to computerize fault diagnosis system.

As shown in Fig. 1, fault diagnosis system is composed of power system, DBMS (Data Base Manage System), DAU (Data Acquisition Unit), HMI(Human-Machine Interface), Inference Engine, FEP(Front-End_Processor), etc.

DAU is installed in every substation and gathers the state of CB(Circuit Breaker), DS(Disconnecting Switch), Ry(Relay) every 5 seconds and sends data to FEP through TCP/IP protocol.

When the state of these components is changed, FEP writes the information of CB, DS, Ry. Then FEP passes the window message to Inference Engine to simulate the faulted situation. Then, Inference Engine accesses DB, reads the state of power system and writes the result of fault diagnosis like faulted component, malfunctioned facilities, blackout area etc.

When Engine finished the diagnosis of faulted situation, it passes messages to HMI. HMI updates the window and alarms to the operator.

2.2 Representation of power systems

First, it is very important to represent the power system for the system analysis. In this paper, each component of power system is represented as object using OOP(Object Oriented Program) technique. Classes for component of power system are designed and total system can be built easily by linking the objects. The designed classes are shown in Fig 2 - Bus class, TR class, Generator class, Feeder class, Line class etc.

The every object in the program is similar to every element of actual system. Also, Objects should be made to transmit necessary messages between each other elements. In this program, pointer makes the message transferring between objects, also this connection has dual connection structure between objects.

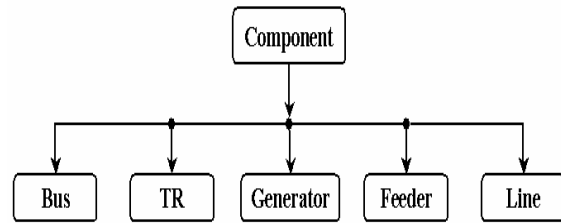

Fig. 2. The class for the component of power system.

Example system is composed of 3 buses, 2 transmission lines, 1 transformer, 1 generator, 1 shunt capacitor and 1 load.

Fig. 4 shows object diagram of Fig. 3. Each arrow can be added or deleted, which means message exchange between each class.

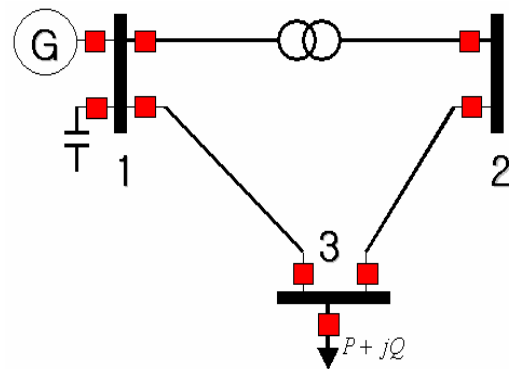

Fig. 3. The example of 3-bus system.

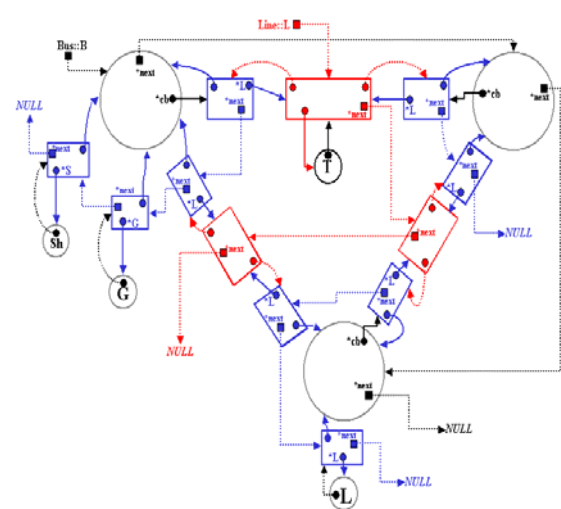

Fig. 4. Object Diagram

In Fig. 4, bus object is connected with line objects, generator object, and shunt capacitor object through circuit breaker. In this object diagram, all the objects can pass and take messages between them.

2.3 Representing the diagnosis knowledge of the expert

Fig. 5 is modules for fault diagnosis. These modules are made by small common part in power system. In large and complicated power system, fault diagnosis is very difficult to represent all the information into knowledge base. Moreover, the knowledge base has to be rebuilt when the state of the system component or the system configuration is changed. In this paper, whole system is divided into several small parts and diagnosis module is applied in it. Therefore final goal can be decided by the combination of the results of several modules. 12 modules of in the Fig. 5 are needed for diagnosis the faulted situations. The entire faulted situation can be included in these 12 modules. Suffix 154 and 22 means 154kV and 22.9kV system in Fig. 5. And equipment without any notation can be used irrelevant to the voltage grade.

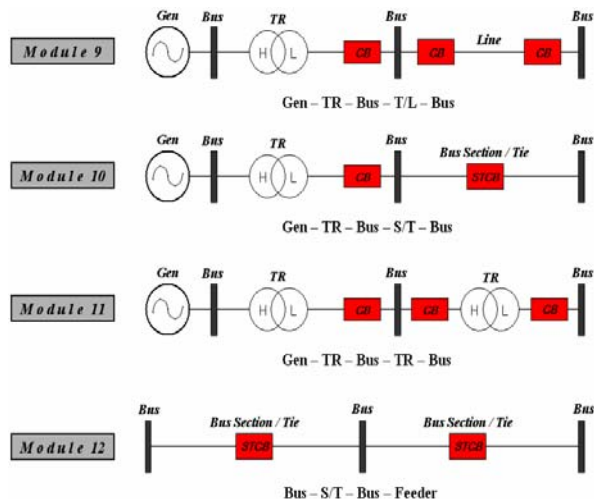
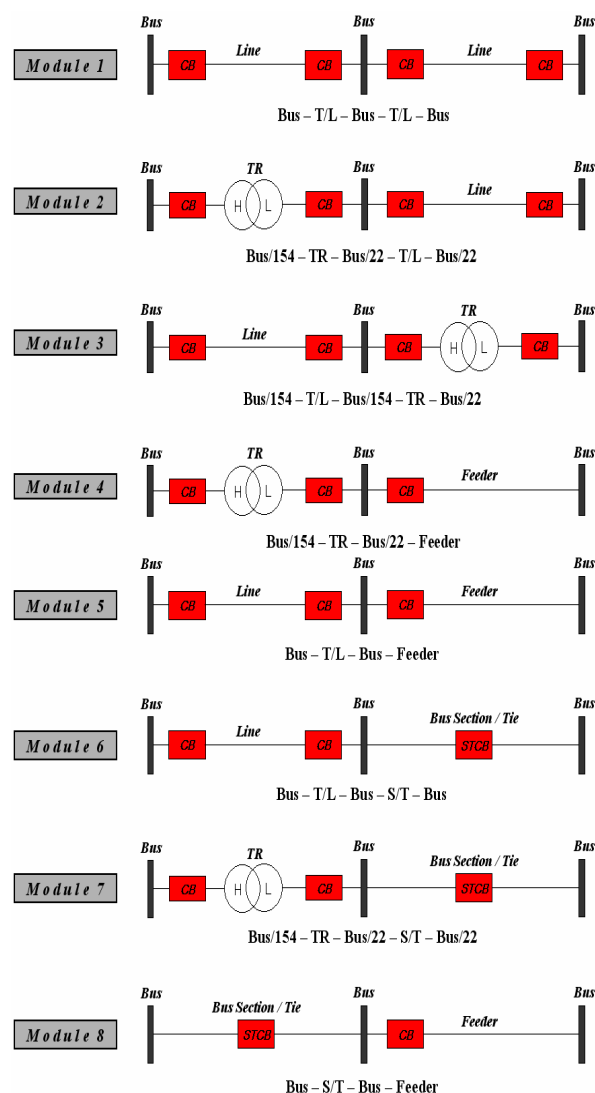

Fig. 5. Modules for fault diagnosis in power system.

Table 1 shows Relay set-up information of all equipments.

Table 1. Relay set-up information of all equipments.

Equipment	1	2	3	4	5	6	7	8	9	10	11
T/L	PW	67S-H	67S-L	OCG	OCR-H	OCR-L	67RP				
TR	63B	63TSP	96B2	63SP	87T	OCR-H	OCR-L	OCG	51N	67G	67RP
FEEDER	PW	OCR-H	OCR-L	OCG	67RP	85H	5E				
Bus	BP	B-OCR	UV	OVG	BP-T						
Gen	PW	67S-H	GEN-H	5E	FCB	ATS					

Fig. 6 shows specific structure about module 1 that appears in Fig. 5.

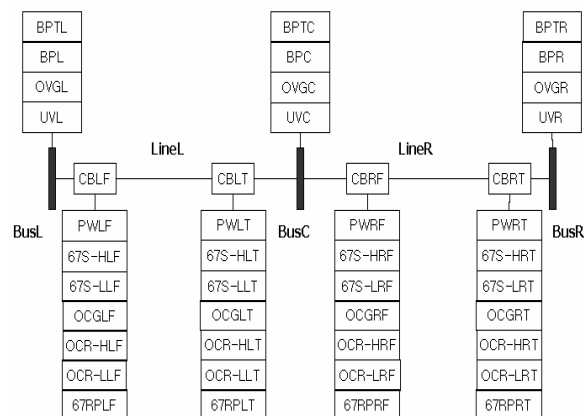

Symbol	Description	Symbol	Description
L	Left	BP (T)	Bus Protection (Total) Ry
C	Center	CB	Circuit Breaker
R	Right	PW	Pilot Wire Relay

F	From	67S	H	Directional OCR(High)
T	To		L	Directional OCR (Low)
UV	Under Voltage Ry	OCG		Over Current Ground Ry
67RP	Reverse Power Ry		OCR	H
OVG	Over Voltage Ground			L

Fig. 6. Structure and explain of module 1.

Fig. 6 expresses all Ry and CB that are installed in one module. Each module has knowledge about faulted situation.

Fig. 7 is the structure of the knowledge base.

In this way, logic gate AND (symbol : \times) as the condition that must happen at the same time and OR (symbol : $+$) as the condition that is possible even if the one event of the several event happens are expressed.

$A \times B = C$ means the events of A and B must happen at the same time and C equipment is the fault as figure. And $C + D = X$ has meaning that either C event or D happens, X equipment is fault. Knowledge of module 1 is explained by ditto method.

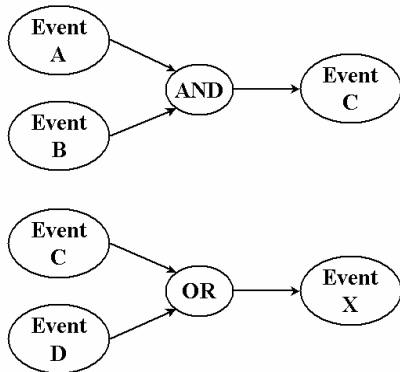

Fig. 7. Expression of knowledge for $A \times B = C$ and $C + D = X$

Fig. 8 is Knowledge input unit. Because there are so many fault cases, it is difficult to input every case one by one. Therefore, we developed this tool.

As Fig. 8, Knowledge input unit of form such as module is developed and situation such as fault's case is created by this tool. For example, if we represent "LineL" as the main protection knowledge, then the equation that explain this situation is as follows (1):

$$CBLF \times CBLT \times PWLF \times PWLT \times UVL \times UVC = \text{LineL} \quad (1)$$

Equation (1) says that LineL is in fault condition when all relays and breakers of left side of the equation are on state. And it must satisfy equation (2) so that module 1 to be in fault condition.

$$\text{BusC} + \text{LineL} + \text{LineR} = \text{MODULE 1} \quad (2)$$

Equation (2) means that any one of BusC, LineL and LineR is in fault condition then module 1 is in fault. Remaining knowledge of LineL, BusC and LineR are made by this method. But there is no knowledge of

BusL and BusR. Because their knowledge can't find if Module is not moved to right and left side and setup information of CB, DS is not found. Therefore, knowledge of BusC, LineL and LineR can be made.

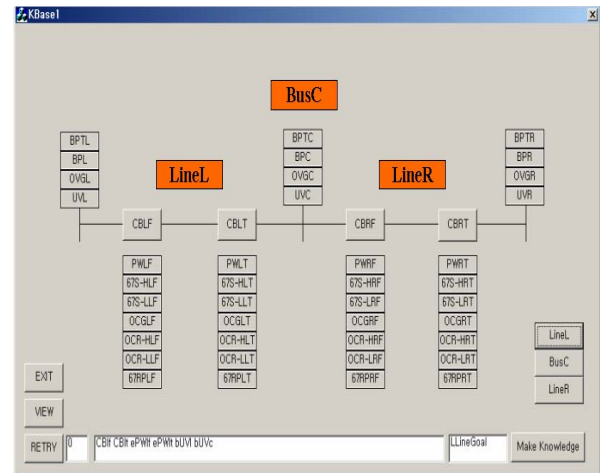

Fig. 8. Knowledge input unit.

2.4 Inference Engine

After the modules and the knowledge are completed, the program uses the inference method as following. First, the program searches modules, which includes the event that happened and then the program calls for the knowledge base that searched modules have. Finally, it compares the event with the knowledge base of the module. If there is case that agrees so, it shows appropriate result. There is a case when the equipment should be act but didn't act. Also, the opposite situation may be happen. They must be also distinguished. The processes that have distinguished unwanted operation equipment and failure to operation equipment are explained in Fig. 9 and Fig. 10.

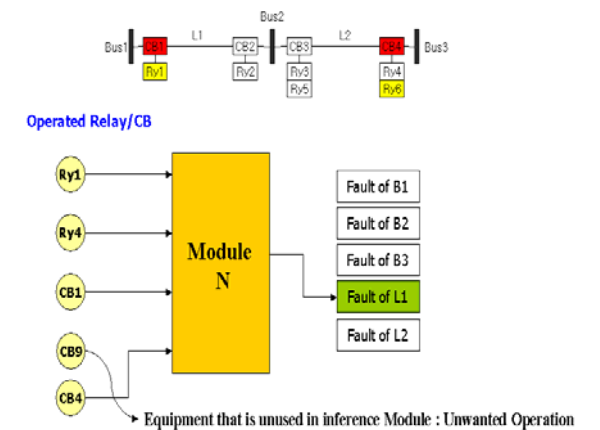

Fig. 9. Judgment of unwanted operation of Ry.

Fig.9 shows the inputs of CBs and Rys to the module N. In spite of unwanted operation of CB (CB9), the final diagnosis result is the fault of L1. Because CB9

is not used in this inference process, CB9 is classified as unwanted operation equipment. Fig. 10 is process that judges equipment that doesn't act. Ry1, Ry4, CB1 and CB4 acted like as Fig. 10. The combination of events is the backup protection. The occurring of backup protection means that any equipment did not act properly. In this way main protection events and backup protection events are distinguished easily.

If compare acted backup protection events with main protection events, event that does not act of main protection event is appeared. Backup protection events are Ry1, Ry4, CB1 and CB4 and main protection events are Ry1, Ry2, CB1 and CB2 in Fig. 10. If compare each other, CB2 did not act in main protection event. Therefore, CB2 is failure to operate equipment.

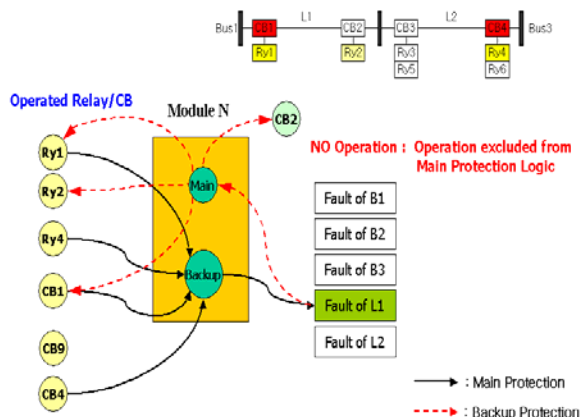

Fig. 10. Judgment of the no operation of the equipment.

3. Application to Power Systems

The example case was simulated with the developed fault diagnosis program. As in Fig.11, short circuit fault happened. In this case the events that happened in this power system is as follows.

The events occurred at substation A, B are the operation of UV(Under Voltage Relay). Also the PW(pilot wire relay) and CB(circuit breaker) which is located between substation A and B are operated.

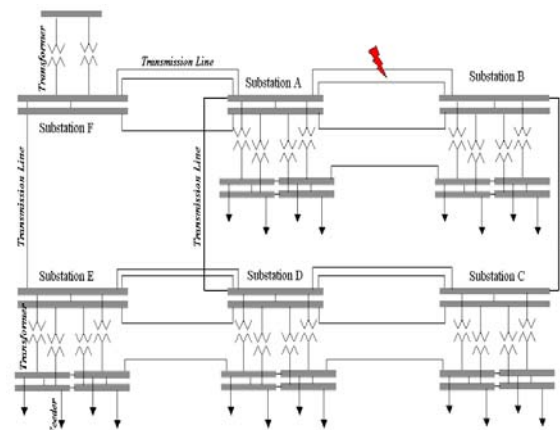

Fig. 11. Assumption of fault in the power system.

These events are used for the input of the inference engine. The HMI for the events and the results of the diagnosis was developed as in Fig. 12. The diagnosis process was also available in this figure.

The contents of the diagnosis results include the false or no operation of the equipments. The processing time was very short compared with other developed systems. It takes no time in this case. For other cases we obtained the similar results.

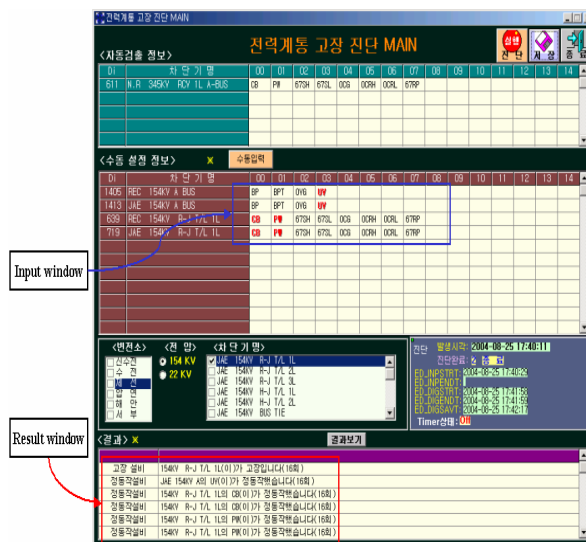

Fig. 12. Simulation result of the fault diagnosis.

4. CONCLUSIONS

In this paper, new diagnosis algorithm that used the idea of module is proposed. The results are as follows

1. The OOP technique is applied to the modelling of power system. Pointers that linked with objects enable transferring messages between objects. By changing this links, total system can be revised. This enables the fast actions to change the state of system components.
2. Large power system is divided into small parts. Diagnosis module is implemented only in small parts of the system. Therefore, diagnosis of huge system is possible with ease and rapidity.
3. In any situation, the system operator can make objective judgment with the fault diagnosis program. Therefore the power system can be more reliable and stable.

REFERENCES

Young Moon Park, Gwang-Won Kim, Jin-Man Sohn, "A Logic Based Expert System (LBES) for Fault Diagnosis of Power System", *IEEE Trans. on PWRs*, Vol. 12, No. 1, pp. 363-369, February 1997.

- Chihiro Fukui, Junzo Kawakami, "An Expert System for Fault Section Estimation Using Information from Protective Relays and Circuit Breakers", *IEEE Trans. on PWRD*, Vol. 1, No. 4, pp. 83-90, October 1986.
- Hong-Tzer Yang, Wen-Yeau Chang, Ching-Lien Huang, "On-Line Fault Diagnosis of Power Substation Using Connectionist Expert System", *IEEE Trans. on PWRD*, Vol. 10, No. 1, pp. 323-331, February 1995
- Yasuji Sekine, Yoshiakira Akimoto, Masahiko Kunugi, Chihiro Fukui, Shinta Fukui, "Fault Diagnosis of Power Systems", *Proceedings of the IEEE*, Vol. 80, No. 5, May 1992.
- Mike Foley, Anjan Bose, "Object-Oriented On-Line Network Analysis", *IEEE Trans on PWRD*, Vol. 10, No. 1, pp. 125-132, February 1995.
- George F.Luger, William A. Stubblefield, "Artificial Intelligence and the Design of Expert System", The Benjamin/Cummings Publishing Company, Inc. 1989.
- Patrick Henry Winston, "Artificial Intelligence", Addison-Wesley Publishing Company, 1993.
- Charles A.Gross, "Power System Analysis", John Wiley & Sons, 1986.
- Bjarne Stroustrup, "The C++ Programming Language", Addison-Wesley Publishing Company, 1991.