

# ROBUST REJECTION OF PERIODIC AND ALMOST PERIODIC DISTURBANCES

Vishwesh V. Kulkarni,\* Lucy Y. Pao,\*  
Hua Zhong\*

\* *Department of Electrical and Computer Engineering,  
University of Colorado, Boulder, CO. USA.  
Email: vishwesh@colorado.edu, pao@colorado.edu,  
zhongh@colorado.edu*

Abstract: We present algorithms to exponentially reject periodic and almost periodic disturbances, the motivating application being a rejection of reel eccentricity induced disturbances in tape-drive systems. The prevalent periodic disturbance rejection algorithms rely on a constant gain approximation of the system at a particular frequency. These are inadequate for this application because a tape-drive system has parametric uncertainties and because the disturbance is time-varying. We present a robust extension of an existing technique derived by Bodson *et al.* and further use quadratic and parameter-dependent Lyapunov functions to synthesize gain-scheduled feedback compensators. *Copyright*© 2005 *IFAC*

Keywords: disturbance rejection, periodic disturbances, tape drive systems, nonlinear control systems, gain scheduling, linear matrix inequality

## 1. INTRODUCTION

This paper is motivated by the problem of rejecting reel eccentricity induced disturbances in tape drive storage systems. Reel eccentricities induce ripples in the tape tension and the dominant frequency of this disturbance is the same as the transport resonance frequency. The ripple magnitude is inversely proportional to the square root of the tape speed (Lu, 2002, Ch. 2) and is especially large at low speeds. Further, the disturbance frequency is a function of the tape speed and the pack radii. Thus, the disturbance is not periodic but *almost periodic* in the sense that the disturbance frequency varies with time, typically from 20 Hz to 80 Hz, as the tape runs end to end, albeit the rate of variation is small.

Literature on the rejection of periodic disturbances, dubbed *repetitive control*, abounds (Ghosh and Paden, 2000) and largely relies on the internal model principle (Francis and Wonham, 1976). The principle states that a plant output can track a class of reference signals, with the steady-state tracking error approaching zero asymptotically, if a model of the reference signal generator is internally added to the stable closed-loop system; if the input signal has a finite Fourier series, only finitely many internal models need be added. A linear infinite dimensional single-input single-output (SISO) repetitive controller was first derived in (Hara *et al.*, 1988) and a corresponding discrete-time formulation was derived in (Tomizuka *et al.*, 1988) with certain robustness considerations added in (Tsao and Tomizuka, 1994). The internal model principle has been used to reject periodic disturbances in (Brown and Zhang, 2004; Narendra and Annaswamy, 1989; Feng and

---

<sup>1</sup> This work has been supported in part by the Colorado Center for Information Storage.

Palaniswamy, 1992; Chaplin and Smith, 1986), and (Bodson and Douglas, 1997) as well.

Recent work on rejecting a periodic disturbance having an unknown constant frequency includes (Bodson *et al.*, 2001) and (Brown and Zhang, 2004). While (Bodson *et al.*, 2001) propose a feedback controller, (Brown and Zhang, 2004) propose a feedforward adaptive controller based on the internal model principle. Both (Brown and Zhang, 2004) and (Bodson *et al.*, 2001) derive a *linear time invariant* (LTI) model of the underlying nonlinear time-varying system and prove that the LTI system is stable given a particular control law but do not characterize the robustness, which is needed in tape systems because the optical encoders used typically have a very limited resolution and because the reel eccentricity induced disturbance has a variable frequency.

In this paper, we extend the feedback compensation technique of (Bodson *et al.*, 2001) to address the robustness requirement and, furthermore, synthesize a gain-scheduled controller to account for the almost periodic constraints. Because the tape drive system dynamics are a function of the pack radii (Baumgart, 2003) and because the disturbance frequencies are a function of the pack radii and the rate of change thereof (Lu, 2002), our objective is a gain-scheduled controller  $K(\theta)$ :

$$\dot{x}_K = A_K(\theta, \dot{\theta})x_K + B_K(\theta, \dot{\theta})y, \quad u = C_K(\theta, \dot{\theta})x_K$$

for the (augmented) tape drive system  $P(\theta)$ :

$$\dot{x} = A(\theta)x + B(\theta)u, \quad y = C(\theta)x \quad (1)$$

with the disturbance frequency as the scheduling parameter  $\theta$ . The controller is designed to ensure finite gain stability, as defined in Section 2. The plant  $P(\theta)$  is augmented in the sense that the disturbance model is subsumed in the plant dynamics by observing that a sinusoidal disturbance  $\omega_d$  can be modeled as the output  $y_d$  of a narrow-band system  $\mathcal{S}_d$  driven by white noise  $\eta$ :

$$\begin{aligned} \dot{x}_d(t) &= A_d x_d(t) + B_d \eta(t), \quad y_d(t) = C_d x_d(t) \\ A_d &\doteq \begin{bmatrix} 0 & \omega_d \\ \omega_d & 0 \end{bmatrix}, B_d \doteq \begin{bmatrix} 0 \\ 1 \end{bmatrix}, C_d \doteq [0 \ 1]. \end{aligned}$$

The augmented plant  $P(\theta)$  has the state  $\tilde{x} = [x^T \ x_d^T]^T$ . Its system matrix  $A(\theta)$  can be verified to be an affine function of  $\omega_d$  so that as  $\omega_d$  ranges over  $[\omega_*, \omega^*]$ ,  $A(\theta)$  takes values over a polytope. Then, several interesting stability analysis and controller synthesis results using linear matrix inequalities (LMIs) can be applied and specialized.

The paper is organized as follows. Some terminology and the problem formulation are given in Section 2. An overview of the feedback compensator of (Bodson *et al.*, 2001) and a direct

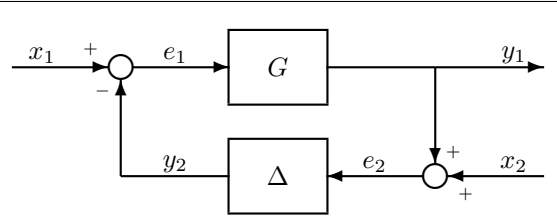

Fig. 1. The feedback system  $\mathcal{S}$  is an interconnection of a linear time invariant operator  $G$  and an otherwise operator  $\Delta$ .

robust extension, along with a numerical example, is given in Section 3. Algorithms to synthesize the desired gain-scheduled compensator are given in Section 4. The paper is concluded in Section 6 after a brief discussion in Section 5. Background results are in the Appendix.

## 2. PROBLEM FORMULATION

The terminology used in this paper is fairly consistent with (Megretski and Rantzer, 1997). We denote a diagonal matrix as  $\text{diag}(\cdot)$ . In stability analysis, a given system  $\mathcal{S}$  is often decomposed into two interconnected subsystems — a linear time invariant subsystem  $G$  in the feedforward path and an otherwise subsystem  $\Delta$  in the feedback path, as shown in Fig. 1. The system  $\mathcal{S}$  is said to be stable if there exists a positive constant  $\kappa$  such that, for all  $T > 0$ ,

$$\int_0^T (|e_1|^2 + |e_2|^2) dt \leq \kappa \int_0^T (|x_1|^2 + |x_2|^2) dt$$

and if, in addition, the map  $(e_1, e_2) \rightarrow (x_1, x_2)$  has a causal inverse on  $\mathcal{L}_2$ . Now, consider an instance of  $\mathcal{S}$  that maps a reference input  $r$  into an output  $y$ , as  $y = P(\theta)e$ ,  $e = r + d - y$  where the signals  $r, y, d \in \mathbb{R}^n$ , and  $P(\theta)$  is possibly uncertain. The problem of interest is to exponentially reject a disturbance  $d(t) = m \cos(\alpha_d(t))$  where  $\dot{\alpha}_d(t) \doteq \omega_d(t)$ ,  $\omega_* \leq \omega_d(\cdot) \leq \omega^*$ . An immediate extension is to exponentially reject a multiple harmonic disturbance  $d(t) = \sum_{i=1}^{\ell} m_i \cos(\alpha_{di}(t))$  where  $\dot{\alpha}_{di}(t) \doteq \omega_{di}(t)$ ,  $\omega_{*i} \leq \omega_{di}(\cdot) \leq \omega_i^* \quad \forall i$ .

## 3. BACKGROUND RESULTS AND EXTENSIONS

Since our work extends the results in (Bodson *et al.*, 2001), we now briefly summarize its compensation technique. The feedback compensation scheme of (Bodson *et al.*, 2001) is shown in Fig. 2. Let us denote the system as  $\mathcal{S}_C$ . Let  $\theta_1, \theta_2$ , and

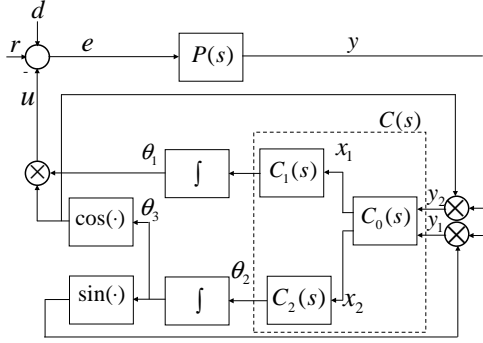

Fig. 2. Feedback compensator of (Bodson *et al.*, 2001) for the rejection of a periodic disturbance  $d$  having unknown frequency.

$\theta_3$  denote the estimates of the disturbance magnitude, frequency, and phase angle, respectively. (Bodson *et al.*, 2001) linearizes the nonlinear dynamic plant  $P$  mapping  $\tilde{u} \doteq [\theta_1 \ \theta_3]^T$  into  $\tilde{y} \doteq [y_1 \ y_2]^T$  as the pure gain operator  $G$  defined as:

$$G = \frac{1}{2} \begin{bmatrix} P_R & -P_I \\ P_I & P_R \end{bmatrix}$$

where  $P_R \doteq \text{Re}(P(j\omega_1))$ ,  $P_I \doteq \text{Im}(P(j\omega_1))$ , and  $\omega_1$  is a design parameter, estimated using either an adaptive notch filter or a phase-locked-loop (Wu and Bodson, 2004). The compensator shown in Fig. 2 is chosen by (Bodson *et al.*, 2001) as

$$C(s) = \text{diag} \left( -g_1 \frac{1}{s}, -g_2 \frac{s+a}{s^2+bs} \right) G^{-1}$$

where  $g_1$  and  $g_2$  are positive scalars. The role of the pre-multiplier  $G^{-1}$  is to cancel out the effect of the plant dynamics on the disturbance signal so that the rest of the compensator can work on the *recovered* disturbance signal to better reject it. Such an exact cancellation is not possible for our problem because the plant is uncertain. An extension for uncertain systems is as follows.

*Lemma 1.* Consider the system  $\mathcal{S}_C$ . Suppose the parameters  $\theta_1$  and  $\theta_2$  vary sufficiently slowly. Let  $z \doteq [\theta_1 - m \cos(\theta_3 - \alpha_d) \ m \sin(\theta_3 - \alpha_d)]^T$ . Then, there exists a  $G \in \mathbb{R}^{n \times n}$  and a finite  $\varepsilon$  such that  $\|y - Gz\| \leq \varepsilon$  where  $y \doteq [y_1 \ y_2]^T$ .  $\square$

**Proof:** The proof is outlined in the appendix.  $\square$

*Remark 1.* Given an uncertain plant  $\tilde{P}$ , Lemma 1 yields a polytope  $\mathcal{G}$  of approximating matrices so that although it is impossible to include a pre-multiplier of the form  $G^{-1}$  in the compensator, the desired effect may be approached by including a pre-multiplier  $M$  obtained as the solution:

$$M \doteq \arg \min_{M \in \mathbb{R}^{n \times n}, \tilde{G} \in \mathcal{G}} \|I - M\tilde{G}\|.$$

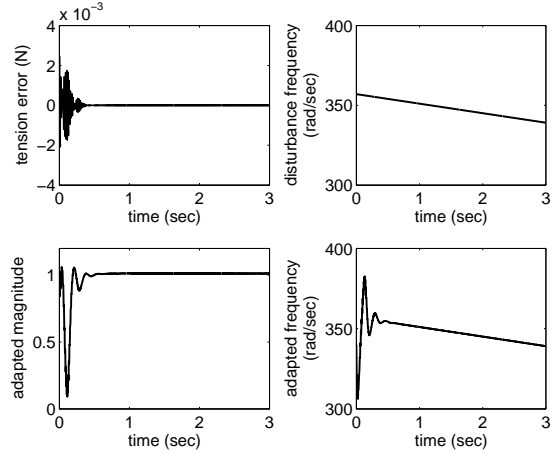

Fig. 3. The simulated system is subject to a disturbance whose frequency decreases monotonically with time. The tension error is reduced by nearly 2 orders of magnitude within 0.4 seconds. The adapted magnitude and frequency track those of the disturbance.

Note that  $M = G^{-1}$  if  $\tilde{P}$  is known precisely. Quadratic stability of the resulting closed-loop system can be checked via (Megretski and Rantzer, 1997, Theorem 1). The operator  $\tilde{G}$  can be augmented with uncertainties and their integral quadratic constraints (IQCs) can be used to obviate the diagonal feedback structure imposed in (Bodson *et al.*, 2001).  $\square$

### 3.1 Numerical Example

We implemented the above robust extension on the tape system model derived in (Baumgart and Pao, 2003). The model is nonlinear and time-varying, and is given by  $\dot{x}(t) = A(t)x + B(t)u(t) + \frac{\varepsilon}{2\pi}\nu(t)$ , where  $\nu$  is a function of  $x \doteq [T(t) \ V_1(t) \ V_2(t)]^T$  and  $U \doteq [u_1(t) \ u_2(t)]^T$ , with  $T(t)$  denoting the tape tension,  $V_i(t)$  denoting the tangential velocity of the tape at each reel, and  $u_i(t)$  denoting the current applied to each DC motor,  $i = 1, 2$ ; the system matrices are too complicated to be stated here and are fully described in (Baumgart and Pao, 2003). The dominant frequency of the reel-eccentricity induced disturbance is the same as the rotating frequency of the corresponding reel, which varies with the change in pack radius because a control objective is to keep the tangential velocity of the tape at a constant value. A sinusoidal signal of unit amplitude was taken to be the reel eccentricity disturbance of the take-up reel and the frequency of the signal was varied at a constant rate. Initially, when the take-up reel is empty, the frequency is 60 Hz. The reel radius then increases continuously until it reaches the maximum value, at which

point the frequency is 20 Hz. This end-to-end transport lasts 30 seconds. After implementing the controller extension of Lemma 1, as Fig. 3 shows, the tension error is close to zero within 0.5 second if the disturbance has a time-varying frequency. The adapted disturbance magnitude converges to one within 1 second; the disturbance frequency is also tracked well. ■

#### 4. GAIN-SCHEDULED COMPENSATORS

The disturbance frequency variations increase the modeling uncertainty because the above method is based on linearization at a single nominal frequency. One solution is to gain-schedule the compensator by gridding the frequency space over the interval of variation, synthesizing a feedback compensator as above at each frequency, and then employing the interpolation algorithms of (Stilwell and Rugh, 2000). However, these interpolation algorithms are known to preserve only asymptotic stability and not the desired quadratic stability.

Now, the tape-drive model of (Baumgart, 2003) is of the form  $\dot{x}_p = Ax_p + B_1y_d + B_2u$ ,  $y_p = Cx_p$ , where the components of  $x_p$  are the tape tension and the tangential reel velocities. Augmenting it with  $\mathcal{S}_d$  yields the system  $\tilde{\dot{x}} = \tilde{A}\tilde{x} + \tilde{B}_1\eta + \tilde{B}_2u$ ,  $\tilde{y} = \tilde{C}\tilde{x}$  where  $\tilde{x} \doteq [x_p^T x_d^T]^T$ ,  $\tilde{C} = [C_p \ 0]$ , and

$$\tilde{A} = \begin{bmatrix} A & B_1C_d \\ 0 & A_d \end{bmatrix}, \tilde{B}_1 = \begin{bmatrix} 0 \\ B_d \end{bmatrix}, \tilde{B}_2 = \begin{bmatrix} B_2 \\ 0 \end{bmatrix}.$$

Only  $\tilde{A}$  is a function of the disturbance frequency; in fact, the function is affine. Furthermore, the augmented system can be represented by a convex combination of two vertices, one corresponding to  $\omega_*$  and the other corresponding to  $\omega^*$ . The number of vertices grows linearly with the number of harmonics in the disturbance. This structure can be exploited to synthesize efficient output feedback gain-scheduling controllers as discussed next. A block diagram of the proposed gain-scheduled controller is shown in Fig. 4. A state-space representation of the closed-loop system  $\mathcal{S}_{CL}$  is given by:

$$\begin{aligned} \begin{bmatrix} \dot{x} \\ \dot{x}_k \end{bmatrix} &= A_{cl}(\theta) \begin{bmatrix} x \\ x_k \end{bmatrix} + B_{cl}(\theta) \begin{bmatrix} v \\ q \end{bmatrix}, \\ \begin{bmatrix} w \\ p \end{bmatrix} &= C_{cl}(\theta) \begin{bmatrix} x \\ x_k \end{bmatrix} + D_{cl}(\theta) \begin{bmatrix} v \\ q \end{bmatrix}, \\ \begin{bmatrix} v \\ q \end{bmatrix} &= \text{diag}(I, \Delta(\theta)) \begin{bmatrix} w \\ p \end{bmatrix}, \\ A_{cl}(\theta) &\doteq \begin{bmatrix} A & 0 \\ 0 & 0 \end{bmatrix} + \mathcal{B}\Omega(\theta)\mathcal{C}, \quad \mathcal{B} \doteq \begin{bmatrix} 0 & B_u & 0 \\ I & 0 & 0 \end{bmatrix}, \\ \mathcal{C} &\doteq \begin{bmatrix} 0 & I \\ C_y & 0 \\ 0 & 0 \end{bmatrix}, \quad B_{cl}(\theta) \doteq \begin{bmatrix} 0 & B_q \\ 0 & 0 \end{bmatrix} + \mathcal{B}\Omega(\theta)\mathcal{D}_{yq}, \end{aligned}$$

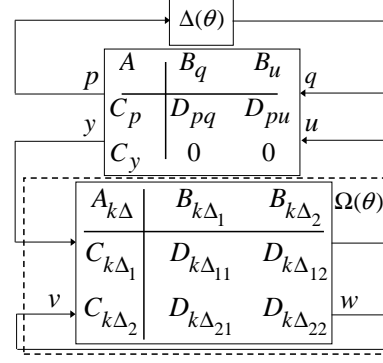

Fig. 4. Proposed gain-scheduled feedback compensator for the rejection of a sinusoidal disturbance having multiple harmonics.

$$\begin{aligned} \mathcal{D}_{yq} &\doteq \begin{bmatrix} 0 & 0 \\ 0 & 0 \\ I & 0 \end{bmatrix}, \quad C_{cl}(\theta) \doteq \begin{bmatrix} 0 & 0 \\ C_p & 0 \end{bmatrix} + \mathcal{D}_{pu}\Omega(\theta)\mathcal{C}, \\ D_{cl}(\theta) &\doteq \begin{bmatrix} 0 & 0 \\ 0 & D_{pq} \end{bmatrix} + \mathcal{D}_{pu}\Omega(\theta)\mathcal{D}_{yq}, \quad \mathcal{D}_{pu} \doteq \begin{bmatrix} 0 & 0 & I \\ 0 & D_{pu} & 0 \end{bmatrix}, \end{aligned}$$

where the compensator state-space realization is given by the matrix  $\Omega(\theta)$  as shown in Fig. 5. Well-known results on the *linear parameter varying* (LPV) and *linear fractional transform* (LFT) techniques may now be gainfully specialized to synthesize the required compensators. In particular, if the problem in Lemma 2, given in the Appendix, is feasible, a gain-scheduling algorithm to synthesize an output feedback compensator is as follows.

Step 1. *Measure  $\theta$  and  $\dot{\theta}$ , and compute  $P(\theta)$ .* Let

$$S = S_0 + \sum_{i=1}^{\ell} \theta_i(t)S_i, \quad R = R_0 + \sum_{i=1}^{\ell} \theta_i(t)R_i.$$

Define  $M_{12} = (L - J^{-1})^{1/2}$ ,  $N_{12} = -JM_{12}$ , and

$$P(\theta) = \begin{bmatrix} S & -S + R^{-1} \\ -S + R^{-1} & S - R^{-1} \end{bmatrix}, \quad M = \begin{bmatrix} I & M_{12}^T \\ M_{12} & L \end{bmatrix}.$$

Then

$$\begin{aligned} P(\theta)^{-1} &= \begin{bmatrix} R & R \\ R & (S - R^{-1})^{-1}SR \end{bmatrix}, \\ M^{-1} &= \begin{bmatrix} I - M_{12}^T N_{12} & N_{12}^T \\ N_{12} & J \end{bmatrix}, \\ \dot{P}(\theta) &= \begin{bmatrix} \dot{S} & -(\dot{S} + R^{-1}\dot{R}R^{-1}) \\ -(\dot{S} + R^{-1}\dot{R}R^{-1}) & \dot{S} + R^{-1}\dot{R}R^{-1} \end{bmatrix}. \end{aligned}$$

Step 2. *Find  $\Omega(\theta)$  such that*

$$X(\theta, \dot{\theta}) + U^T\Omega(\theta)V + V^T\Omega(\theta)^T U < 0, \quad (2)$$

where  $U = [\mathcal{B}^T P(\theta) \ 0 \ \mathcal{D}_{pu}^T]$ ,  $V = [\mathcal{C} \ \mathcal{D}_{yq} \ 0]$ ,

$$X(\theta, \dot{\theta}) = \begin{bmatrix} A_0^T P(\theta) + P(\theta) A_0 + \dot{P}(\theta) & P(\theta) B_0 & C_0^T \\ B_0^T P(\theta) & -M & D_0^T \\ C_0 & D_0 & -M^{-1} \end{bmatrix},$$

$$A_0 = \begin{bmatrix} A & 0 \\ 0 & 0 \end{bmatrix}, B_0 = \begin{bmatrix} 0 & B_q(\theta) \\ 0 & 0 \end{bmatrix},$$

$$C_0 = \begin{bmatrix} 0 & 0 \\ C_p & 0 \end{bmatrix}, D = \begin{bmatrix} 0 & 0 \\ 0 & D_{pq}(\theta) \end{bmatrix}.$$

The solution  $\Omega(\theta)$  gives the state-space matrices of the gain-scheduled controller.

*Remark 2.* The above controller is based on the parameter-dependent Lyapunov function  $V(x, \theta) = x^T P(\theta) x$  and improves on the quadratic Lyapunov function based compensators such as (El-Ghaoui and Niculescu, 2000, Ch. 11) because although the closed-loop system may not satisfy  $A(\theta)^T P + P A(\theta) < 0$ ,  $\forall \theta$  for any  $P > 0$ , it may satisfy  $A(\theta)^T P + P A(\theta) + \dot{P}(\theta) < 0$ ,  $\forall \theta$  for some  $P > 0$ . In general,  $\Omega(\theta)$  has no closed-form solution and requires an LMI solver in run-time.  $\square$

The standard quadratic Lyapunov function is recovered by setting  $S_i = R_i = 0$ ,  $\forall i > 0$ . If the scheduling parameter can neither be measured nor be estimated, the quadratic Lyapunov function based approach enables a sub-optimal and computationally efficient scheduling algorithm as follows.

Step 1. *Design controllers for each vertex of the polytope  $\gamma\Delta$ .* Let  $R, S, L, J$  be a feasible solution to when  $S_i = R_i = 0$ ,  $\forall i > 0$ . Define  $P_{12} = (S - R^{-1})^{1/2}$ ,  $Q_{12} = -R P_{12}$ ,  $M_{12} = (L - J)^{1/2}$ ,  $N_{12} = -J M_{12}$  and

$$P = \begin{bmatrix} S & P_{12} \\ P_{12}^T & I \end{bmatrix}, M = \begin{bmatrix} I & M_{12}^T \\ M_{12} & L \end{bmatrix}$$

for each vertex  $\Delta_i$ . Solve (2) on each vertex to get the corresponding feasible  $\Omega_{\Delta_i}$ .

Step 2. *Design the gain-scheduled controller.* For any  $\Delta(\theta)$ , obtain the interpolating variables  $\nu_i(\theta)$  by solving  $\Delta(\theta) = \sum_i \nu_i(\theta) \gamma \Delta_i$  and set the corresponding controller as  $\Omega(\theta) = \sum_i \nu_i(\theta) \gamma \Omega_{\Delta_i}$ .

Since only  $\tilde{A}$  is a function of  $\omega_d$ , it can be pre-specified that  $\mathcal{D}_{yq} = \mathcal{D}_{pu} = 0$  in both algorithms.

## 5. DISCUSSION

Implementing and testing the gain-scheduled compensators of Section 4 is a topic of future research. The decoupled tape tension control loop

(see (Baumgart, 2003)) exhibits a bilinear dependence on the ratio of the tape radius to the reel inertia and the tape radius. A sub-optimal solution is to use the quadratic Lyapunov function based scheduling algorithm, but the bilinear matrix inequality based algorithms may be expected to give a superior performance.

## 6. CONCLUSION

We have presented algorithms to exponentially reject periodic and almost periodic disturbances, the motivating application being a rejection of reel eccentricity induced disturbances in tape-drive systems. Prevalent techniques such as (Bodson *et al.*, 2001) rely on a constant gain approximation of the system at a specific frequency and need improvements to address parametric uncertainties and time-varying disturbances. Lemma 1 facilitates a simple robust extension of the method of (Bodson *et al.*, 2001). Augmenting the disturbance dynamics to the tape system dynamics enables the use of quadratic and parameter-dependent Lyapunov functions, leading to sophisticated stability analysis and gain-scheduling algorithms. We have presented two such algorithms.

## 7. APPENDIX: BACKGROUND RESULTS AND PROOFS

### Proof of Lemma 1:

Since the parameters  $\theta_1$  and  $\theta_2$  vary sufficiently slowly, if  $\theta_2$  is in the vicinity of  $\omega_1$ , arguments of (Bodson and Douglas, 1997) can be extended to approximate the plant output  $y$  as:

$$y = (P_R + \Delta P_R) \theta_1 \cos(\theta_3) - (P_I + \Delta P_I) \theta_1 \sin(\theta_3) \\ - (P_R + \Delta P_R) d_1 \cos(\alpha_d) + (P_I + \Delta P_I) d_1 \sin(\alpha_d)$$

where  $\Delta P_R \in [-\delta_1, \delta_1]$ ,  $\Delta P_I \in [-\delta_2, \delta_2]$ . Define

$$\delta_1 = \max_{\omega_1, \omega_2 \in [\omega_*, \omega^*]} |\operatorname{Re}(\hat{P}(j\omega_1)) - \operatorname{Re}(\hat{P}(j\omega_2))| \\ \delta_2 = \max_{\omega_1, \omega_2 \in [\omega_*, \omega^*]} |\operatorname{Im}(\hat{P}(j\omega_1)) - \operatorname{Im}(\hat{P}(j\omega_2))|$$

Using a Taylor series approximation and discarding the high frequency components of  $y_1$  and  $y_2$ , we obtain the requisite  $G$  as:

$$G = \frac{1}{2} \begin{bmatrix} P_R & -P_I \\ P_I & P_R \end{bmatrix} + \Delta G, \quad \Delta G \doteq \frac{1}{2} \begin{bmatrix} \Delta P_R & -\Delta P_I \\ \Delta P_I & \Delta P_R \end{bmatrix}.$$

*Lemma 2.* (Wang and Balakrishnan, 2002)  $\mathcal{S}_{CL}$  with full output feedback is robustly stabilizable for all bounded parameter  $\theta$  having bounded rate of variation if there exist  $R_j, S_j, L, J$ , and  $X$  such that

$$\begin{bmatrix} N_R & 0 \\ 0 & I \end{bmatrix}^T \Psi_1 \begin{bmatrix} N_R & 0 \\ 0 & I \end{bmatrix} < 0, \quad \begin{bmatrix} N_S & 0 \\ 0 & I \end{bmatrix}^T \Psi_2 \begin{bmatrix} N_S & 0 \\ 0 & I \end{bmatrix} < 0$$

$$\begin{bmatrix} S & I \\ I & R \end{bmatrix} > 0, \quad \begin{bmatrix} L & I \\ I & J \end{bmatrix} > 0, \quad \begin{bmatrix} L & \Delta(\theta)X \\ X\Delta(\theta) & X \end{bmatrix} > 0$$

where

$$\Psi_1 = \begin{bmatrix} E_{11} & E_{12} & E_{13} \\ E_{12}^T & -J & E_{23} \\ E_{13}^T & E_{23}^T & -J \end{bmatrix}, \quad \Psi_2 = \begin{bmatrix} F_{11} & F_{12} & F_{13} \\ F_{12}^T & -X & F_{23} \\ F_{13}^T & F_{23}^T & -L \end{bmatrix},$$

$$R = R_0 + \sum_{i=1}^{\ell} \theta_i(t) R_i, \quad S = S_0 + \sum_{i=1}^{\ell} \theta_i(t) S_i,$$

$$E_{11} = AR + RA^T - \sum_{i=1}^{\ell} \dot{\theta}_i(t) R_i, \quad E_{12} = RC_p^T,$$

$$E_{13} = B_q(\theta)J, \quad E_{23} = D_{pq}(\theta)J, \quad F_{12} = SB_q,$$

$$F_{11} = A^T S + SA + \sum_{i=1}^{\ell} \dot{\theta}_i(t) S_i, \quad F_{13} = C_p^T L,$$

where  $F_{14} = D_{pq}^T L$  and  $B_q(\theta) \doteq B_q \Delta(\theta)$ ,  $D_{pq}(\theta) \doteq D_{pq} \Delta(\theta)$ , and  $N_R$ , and  $N_S$  comprise the null space of  $[B_u^T \ D_{pu}^T]$  and  $[C_y \ 0]$ , respectively.  $\square$

## REFERENCES

- Baumgart, M. (2003). Control of Web-Winding Systems. PhD thesis. University of Colorado, Boulder, CO.
- Baumgart, M. and L. Pao (2003). Robust Lyapunov-based feedback control of nonlinear web-winding systems. In: *Proc. IEEE Conference on Decision and Control*. pp. 6398–6405.
- Bodson, M. and S. Douglas (1997). Adaptive algorithms for rejection of periodic disturbances with unknown frequency. *Automatica* **33**(12), 2213–2221.
- Bodson, M., J. Jensen and S. Douglas (2001). Active noise control for periodic disturbances. *IEEE Trans. Control Systems Technology* **9**(1), 200–205.
- Brown, L. and Q. Zhang (2004). Periodic disturbance cancellation with uncertain frequency. *Automatica* **40**, 631–637.
- Chaplin, G. and R. Smith (1986). Method and apparatus for canceling vibrations from a source of repetitive vibrations. Technical report. US Patent and Trade Organization: Patent No. 4566118.
- El-Ghaoui, L. and S. Niculescu (2000). *Advances in Linear Matrix Inequality Methods in Control*. Advances in Design and Control. SIAM. Philadelphia, PA.
- Feng, G. and M. Palaniswamy (1992). A stable adaptive implementation of the internal model principle. *IEEE Trans. Automatic Control* **37**(8), 1220–1225.
- Francis, B. and W. Wonham (1976). The internal model principle of control theory. *Automatica* **12**, 457–465.
- Ghosh, J. and B. Paden (2000). Nonlinear repetitive control. *IEEE Trans. Automatic Control* **45**(5), 949–954.
- Hara, S., Y. Yamamoto, T. Omata and M. Nakano (1988). Repetitive control system: A new type servo system for periodic exogenous signals. *IEEE Trans. Automatic Control* **33**(7), 659–668.
- Lu, Y. (2002). Advanced Control for Tape Transport. PhD thesis. Carnegie Mellon University, Pittsburg, PA.
- Megretski, A. and A. Rantzer (1997). System analysis via integral quadratic constraints. *IEEE Trans. Automatic Control* **42**(6), 819–830.
- Narendra, K. and A. Annaswamy (1989). *Stable Adaptive Systems*. Prentice Hall. Englewood Cliffs, New Jersey.
- Stilwell, D. and W. Rugh (2000). Stability preserving interpolation methods for the synthesis of gain scheduled controllers. *Automatica* **36**, 665–671.
- Tomizuka, M., T. Tsao and K. Chew (1988). Discrete-time domain analysis and synthesis of repetitive controllers. In: *Proc. American Control Conference*. pp. 860–866.
- Tsao, T. and M. Tomizuka (1994). Robust adaptive and repetitive digital tracking control and application to a hydraulic servo for non-circular machining. *ASME Journal on Dynamics Systems Measurement and Control* **116**(3), 24–32.
- Wang, F. and V. Balakrishnan (2002). Improved stability analysis and gain-scheduled controller synthesis for parameter-dependent systems. *IEEE Tran. Automatic Control* **47**, 720–734.
- Wu, B. and M. Bodson (2004). Multi-channel active noise control for periodic sources — indirect approach. *Automatica* **40**, 203–212.