

# FRAMEWORK FOR A SMART PROCESS DATA ANALYTICS PLATFORM

Wenkai Hu<sup>1</sup>, Sirish L. Shah\*<sup>2</sup> and Tongwen Chen<sup>1</sup>

<sup>1</sup> Department of Electrical & Computer Engineering, University of Alberta

<sup>2</sup> Department of Chemical & Material Engineering, University of Alberta  
Edmonton, AB, Canada T6G 1H9

## *Abstract*

The fusion of information from disparate sources of data is the key step in devising strategies for a smart analytics platform. In the context of the application of analytics in the process industry, this paper provides a framework for seamless integration of information from process and alarm databases complimented with process connectivity information. The discovery of information from such diverse data sources can be subsequently used for process and performance monitoring including alarm rationalization, root cause diagnosis of process faults, hazard and operability analysis, safe and optimal process operation. The utility of the proposed framework is illustrated by several successful industrial case studies.

## *Keywords*

Analytics, big data, performance monitoring, process monitoring, alarm systems, process data analytics, fault detection and diagnosis.

## **Introduction**

Process data analytic methods rely on the notion of sensor fusion whereby data from many sensors and alarm tags are combined with process information, such as physical connectivity of process units, to give a holistic picture of health of an integrated plant.

The discovery and learning from process and alarm data refer to a set of tools and techniques for modeling and understanding of complex data sets. Such data sets generally include normal numerical (or non-categorical) data but should also take into account categorical (or non-numerical or qualitative) data from Alarm and Event (A&E) logs combined with process connectivity or topology information. The later refers to the capture of material flow streams in process units as well as information flow-paths in the process due to control loops. This is particularly useful when one is analyzing data from highly integrated

processes to understand propagation of process faults as would be required in HAZard and OPERability (HAZOP) analysis for safe process operation. Highly interconnected process plants are now a norm and the analysis of root causes of process abnormality including predictive risk analysis is non-trivial. It is the extraction of information from the seamless fusion of process data, alarm and event data and process connectivity that should form the backbone of a viable process data analytics platform. This paper focuses on an attempt to create such a platform. This idea of information fusion in the context of process data analytics is depicted in Figure 1.

For efficient and informative analytics, data analysis is ideally carried out in the temporal as well as spectral domains, on a multitude and NOT singular sensor signals to detect process abnormality, ideally in a predictive mode. With the explosion of applications of analytics in diverse areas (such as aircraft engine prognosis, medicine, sports, finance, insurance, social sciences and the advertising industry) statistical learning skills are in high demand. The emphasis in this study is on tools and techniques that help in the process of understanding data and discovering information that would lead to predictive monitoring and

---

This work was supported by the Natural Sciences and Engineering Research Council of Canada.

\* To whom all correspondence should be addressed  
([sirish.shah@ualberta.ca](mailto:sirish.shah@ualberta.ca)).

diagnosis of process faults, alarm rationalization and safe and optimal process operation.

Typical process data analytic methods require the execution of following steps:

- 1) Data quality assessment, such as outlier detection, data normalization, and noise filtering;
- 2) Data visualization and segmentation;
- 3) Process and performance monitoring including root cause detection of faults;
- 4) Alarm data analysis;
- 5) Data-based process topology discovery and validation.

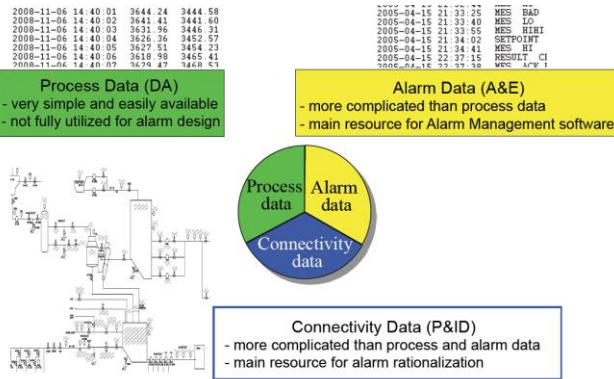

Figure 1. Ingredients of a smart process data analytics platform to enable seamless fusion of information from process and alarm data combined with process connectivity information.

The focus of this paper is to introduce a framework for a smart analytics platform supported by industrial case studies to demonstrate the practical utility of such a tool. In this vein this paper is organized as follows: First, main features of this data analytics platform are introduced in detail, including several functional modules, such as the alarm data analysis, alarm system design, process data analysis, and causality inference. To demonstrate the utility of these functional modules, several case studies involving real industrial data are presented. The concluding remarks are given in the last section.

### Framework for a Data Analytics Platform

A comprehensive platform should integrate a variety of basic statistical functions as well as advanced analytical features, which are powerful and insightful in analyzing either continuous-valued process data or binary-valued alarm data as well as additional categorical data. The proposed analytics platform consists of a data loading section and four functional modules as shown in Figure 2. “Data Loading” imports, reorganizes, merges, or exports alarm data and/or process data. The functional module “Alarm Data Analysis” provides analytic and reporting functions to analyze and visualize alarm data. The remaining three functional modules are based on process data. The “Alarm Configuration Analysis” module designs univariate alarm systems for specific process variables.

The “Process Data Analysis” module visualizes and analyzes process data from either time or frequency perspective. The “Connectivity & Causality Analysis” module uncovers correlations and causal relations between process variables. In addition, a data summary section displays the basic information of loaded alarm data and/or process data. Details and features in each functional module are presented in the following subsections. The framework allows merging of process and alarm data, and gives exploratory as well as analytical insights in the extraction of information from such data.

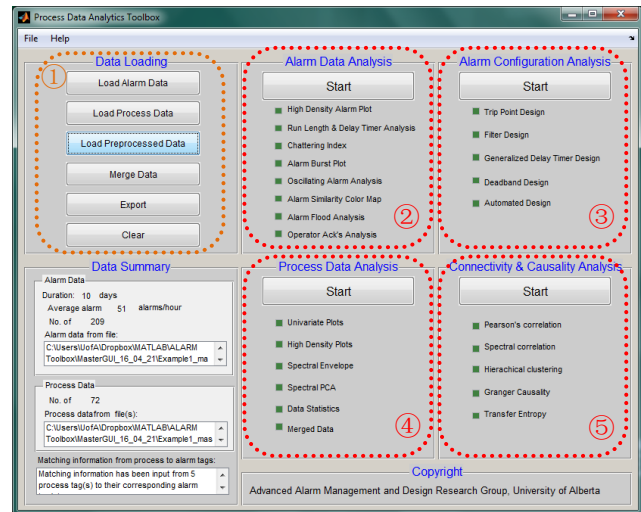

Figure 2. Functional modules for a process data analytics toolbox.

### Data Loading

“Data Loading” is the first highlighted part in Figure 2. It has six functions that can fulfill different functions related to data loading, including alarm data loading, process data loading, data exporting, preprocessed data loading, data matching, and data clearing. The descriptions of these functions are listed in Table 1.

Table 1. Tasks in “Data Loading”.

Function	Task
Load Alarm Data	Load alarm data from an Excel file with structured data format.
Load Process Data	Load process data from an Excel file with structured data format.
Load Preprocessed Data	Load alarm and/or process data from a MATLAB data file with a reorganized data format.
Merge Data	Associate the tags of process variables with their corresponding alarm tags.
Export	Export the alarm data and/or process data as a MATLAB data file with a reorganized data format.
Clear	Clear alarm and/or process data.

To import alarm historian data to the platform, an Alarm & Event (A&E) log file in Microsoft Excel format is needed. Databases from various vendor systems can be exported into this toolbox by first converting them into Excel files. Several requirements on the log file should be satisfied: (1) Each row should reflect one event message; (2) each column should be a certain field of event messages; (3) the same column in all the sheets of the log file should represent the same field. A typical A&E log usually consists of configuration attributes, e.g., the tag name, alarm identifier, priority and location, and realtime messages such as alarm occurrences (ALM), return-to-normal instants (RTN), and their time stamps (Izadi et al. 2010; Kondaveeti et al. 2012). Among these attributes and messages, the following pieces are key and necessary: time stamp, tag name, tag identifier, and message type. They may have different field headers in the data archived from different vendor systems, but usually all of these four pieces of information are provided. In addition to this, the priority and unit information are optional for the data loading depending on whether the two pieces of information are archived or not. An example of A&E log in Excel format is shown in Figure 3. The four mandatory attributes and two optional attributes are highlighted by red and blue dashed rectangles, respectively.

	A	B	C	D	E	F	G	H
1	Time	Journal	Tag	Alarm	State	Priority	Unit	ALENBSST
2	12/30/2014 01:20:13 PM	Alarm	Tag12	PVLO	RTN	LOW	Plant3_Unit2_A2	Enabled
3	12/30/2014 01:21:15 PM	Alarm	Tag2	PVLO	ALM	LOW	Plant3_Unit2_B12	Enabled
4	12/30/2014 01:21:52 PM	Alarm	Tag3	COMM	ALM	LOW	Plant3_Unit2_B13	Enabled
5	12/30/2014 01:21:54 PM	Alarm	Tag2	PVLO	ACK	LOW	Plant3_Unit2_B12	Enabled
6	12/30/2014 01:22:33 PM	Alarm	Tag5	PVBAD	ACK	LOW	Plant3_Unit12_TR21	Enabled
7	12/30/2014 01:24:08 PM	Alarm	Tag16	PVHI	ALM	LOW	Plant3_Unit15_TR21	Enabled
8	12/30/2014 01:26:58 PM	Alarm	Tag7	DISC	RTN	LOW	Plant1_Unit22_FT119	Enabled
9	12/30/2014 01:27:00 PM	Alarm	Tag8	DISC	RTN	LOW	Plant1_Unit22_FT118	Enabled
10	12/30/2014 01:31:57 PM	Alarm	Tag9	BYFS	ACK	HIGH	Plant1_Unit22_FT119	Enabled
11	12/30/2014 01:31:57 PM	Alarm	Tag10	BYFS	ACK	HIGH	Plant3_Unit3_A11	Enabled
12	12/30/2014 01:33:41 PM	Alarm	Tag12	PVLO	ALM	LOW	Plant3_Unit2_A2	Enabled
13	12/30/2014 01:39:10 PM	Alarm	Tag12	FAIL	ALM	LOW	Plant3_Unit2_A2	Enabled
14	12/30/2014 01:39:10 PM	Event	TagEv13				Plant3_Unit2_A2	
15	12/30/2014 01:39:31 PM	Alarm	Tag11	DISC	ALM	LOW	Plant3_Unit2_B12	Enabled
16	12/30/2014 01:43:31 PM	Alarm	Tag11	DISC	RTN	LOW	Plant3_Unit2_B12	Enabled
17	12/30/2014 01:43:59 PM	Alarm	Tag17	PVHI	ALM	EMERGENCY	Plant3_Unit17_TN79	Enabled
18	12/30/2014 01:45:33 PM	Alarm	Tag20	CFN	ALM	HIGH	Plant3_Unit17_TN79	Enabled
19	12/30/2014 01:45:37 PM	Event	TagEv22				Plant1_Unit12_FT116	
20	12/30/2014 01:45:38 PM	Alarm	Tag25	FAIL	ALM	LOW	Plant3_Unit2_A2	Enabled

Figure 3. An example of A&E log.

To import historical process data to the platform, files that store historical measurements of process variables in Microsoft Excel format are needed. Process data has totally different format compared to alarm data. Several requirements on the Excel files should be satisfied: (1) The first column should be time stamps of the sampling instants; (2) the following columns store the historical values of process variables at these sampling instants. If the time stamp information is not available, an Excel file without the time stamp column is also acceptable. The log file of process data has a much simpler structure compared with the A&E log, and usually includes three parts, namely, tag names, measurements, and time stamps. An example of a process data stream is presented in Figure 4. The tag names, measurements, and time stamps are highlighted by green, blue, and red dashed rectangles, respectively.

Once the alarm and/or process data are loaded, the platform will reorganize them in a format that can be easily processed by the analytical functions. Exporting data before closing the platform is recommended, since it is much less time-consuming to import the preprocessed data in .mat format than to import the raw data stored in Excel,

especially for subsequent analysis. If both the alarm data and process data are loaded, then all the process variables that have observations during the time-window of the alarm dataset are listed. Macros can be created to associate alarm tags with a listed process variable. Some basic information about the data set is shown in the information section at the bottom left corner of Figure 2. It shows the directories of the alarm data and process data files, respectively. Alarm historian duration, average alarm rate, number of alarm tags, number of process tags, and number of process tags that have been matched to alarm tags are also provided if available.

	A	B	C	D	E	F	G
1	Time Stamps	Tag01	Tag02	Tag03	Tag04	Tag05	Tag06
2	16/06/2016 10:22:25	10.0103	9.9502	0.0660	0.0392	0.1095	0.0956
3	16/06/2016 10:22:30	9.9502	9.9569	0.0657	0.0392	0.1095	0.0957
4	16/06/2016 10:22:35	9.8577	9.8463	0.0657	0.0390	0.1092	0.0957
5	16/06/2016 10:22:40	10.0313	9.9235	0.0658	0.0390	0.1092	0.0956
6	16/06/2016 10:22:45	9.9922	10.0046	0.0658	0.0396	0.1093	0.0956
7	16/06/2016 10:22:50	10.0027	10.0961	0.0658	0.0396	0.1093	0.0955
8	16/06/2016 10:22:55	10.0523	10.1200	0.0658	0.0401	0.1089	0.0955
9	16/06/2016 10:23:00	10.0914	9.8882	0.0655	0.0401	0.1089	0.0955
10	16/06/2016 10:23:05	10.1295	10.0513	0.0655	0.0400	0.1092	0.0955
11	16/06/2016 10:23:10	10.0627	10.0017	0.0659	0.0400	0.1092	0.0956

Figure 4. An example of process data.

#### Alarm Data Analysis

This functional module provides a variety of functions for the analysis of alarm data, including basic *statistical features*, such as the reporting of top bad actors, calculation of average/peak alarm rates, and Operator Acknowledgement Analysis (OPAA), *advanced data analytics*, such as the Run Length Distribution & Delay Timer Analysis (RLD&DTA), Chattering Index (CI), Oscillating Alarm Analysis (OAA), Alarm Flood Analysis (AFA), Causality Inference for Alarms (CIA), and Mode-Dependent Alarm Analysis (MDAA), plus powerful *visualization plots*, such as the High Density Alarm Plot (HDAP), Alarm Burst Plot (ABP) and Alarm Similarity Color Map (ASCM). This functional part is helpful for issuing weekly or monthly assessments/recommendations of alarm management. But it is not merely a simple Key Performance Indicator (KPI) calculator as it has many advanced features that can help in alarm rationalization. The descriptions of these functions are listed in Table 2.

To observe top bad actors and visualize changes of KPIs, HDAP and ABP can be used. A High Density Alarm Plot (HDAP) is useful for visualizing large amounts of alarm data over a selected period (Kondaveeti et al. 2012). It displays alarm counts for top bad actors using a color map and provides an overall picture of alarm data without getting into details of each alarm variable. Using a sliding time window of 10 minutes, the peak alarm rate is calculated along with time and can be visualized using a line graph, namely, the Alarm Burst Plot (ABP) (Hollifield & Habibi 2011).

Correlated alarms are referred to as alarms occurring within a short time period of each other. They could be either redundant or overlapping in indicating the same abnormality. Therefore, the detection and quantification of

correlated alarms are important. Based on the alarm correlations, redundant alarms can be removed and related alarms can be grouped. A variety of methods have been developed and demonstrated to be effective using industrial case studies (Noda et al. 2011; Kondaveeti et al. 2012; Yang et al. 2013; Hu et al. 2015). In this functional part, the correlation metrics are visualized by an Alarm Similarity Color Map (ASCM), where correlated alarms are clustered, and thus can be easily identified (Kondaveeti et al. 2012; Yang et al. 2012).

Table 2. Functions in “Alarm Data Analysis”.

Function	Task
HDAP	Visualize alarm data over a selected time period using a high density color map.
RL&DTA	Design on/off delay timers based on run length distributions.
CI	Detect chattering alarms and calculate chattering indices.
ABP	Calculate and visualize the peak alarm rate.
OAA	Discover alarms caused by process oscillations.
ASCM	Detect correlated alarms and visualize their similarity indices using a color map.
AFA	Analyze alarm floods, including identification, comparison, and clustering of alarm floods.
OPAA	Analyze the operator acknowledgement, including the acknowledgement rate and response time.
CIA	Detect causal relations between alarm variables.
MDAA	Detect mode-dependent nuisance alarms.

Chattering alarms are major contributors of alarm overloading. According to ANSI/ISA-18.2 (2009), any alarm occurring more than 3 times over a 60 seconds period is likely to be chattering. To identify chattering alarms and quantify their severities, a Chattering Index (CI) was developed based on Run Length Distribution (RLD) (Nagoosi et al. 2011; Kondaveeti et al. 2013). CI takes values between 0 and 1, with a value closer to 1 corresponding to a more serious chattering problem. To reduce chattering alarms, delay timers are effective tools (Kondaveeti et al. 2013; Wang & Chen, 2013 & 2014). Kondaveeti et al. (2013) and Adnan et al. (2013) provided effective ways for the design of delay-timers, which is available in RL&DTA.

An oscillating alarm is a special case of chattering or repeating alarms, which is caused by oscillatory processes. An oscillating alarm, as identified by periodicity in the alarm tag, is an indication of some underlying process oscillation. The oscillating alarms can be easily detected offline using the method in (Cheng 2013) and online using

the method in (Wang & Chen 2013). Specifically, the offline method, namely OAA, is incorporated in this platform, to detect oscillating alarms based on the periodicity in alarm states.

Alarm floods typically arise during a situation when a process abnormality propagates leading to triggering of a large number of annunciated alarms over a short period that often exceeds the operator’s ability to respond in a timely manner to mitigate the fault(s). An alarm flood is said to be raised when the number of annunciated alarms reaches 10 alarms over a 10 minutes period per operator, and be cleared when the number drops below 5 alarms over a 10 minutes period (ISA-18.2 2009; EEMUA-191 2013; IEC 2014). Alarm floods are common in alarm systems and have various negative effects (Nimmo 2005; Timms 2009; Beebe et al. 2013). To analyze alarm floods, AFA functions enable analysis in two steps. First, alarm floods are identified from historical alarm data and highlighted in an alarm burst plot. Second, alarm floods are compared in pairwise using sequence alignment algorithms, such as Dynamic Time Warping (DTW) (Müller 2007; Ahmed et al. 2013), modified Smith Waterman (SW) algorithm (Smith & Waterman 1981; Cheng et al. 2013a), and BLAST-like algorithm (Altschul et al. 1990; Hu et al. 2016a). Furthermore, sequence patterns of alarm floods can be found using a multiple sequence alignment algorithm in (Lai & Chen 2015).

To identify abnormality propagation paths and assist in the root cause detection, the CIA function provides a practical way to detect causal relations between alarms. Based on the detection results, users are able to make a more reliable judgement on how an abnormality propagates from one alarm to another and relate it to experiences from similar abnormal events in the past (Hu et al. 2016b). In this way the alarm flood event clustering analysis allows one to develop a canonical fingerprint of common faults that trigger an alarm flood and also identify appropriate corrective actions that need to be taken to mitigate the abnormality rapidly.

To analyze the interactions between alarms and operator responses, the OPAA and MDAA functions have been developed. The OPAA includes three plots to visualize the alarm states and operator acknowledgements (Ack’s) in a high density color map, compare the alarm count and Ack’s count for each unique alarm using a bar chart, and show the response time for acknowledging an alarm using a boxplot. The MDAA function discovers the association rules of mode-dependent alarms from A&E logs, where both the alarm data and operator actions should be available. The results can be used to assist in configuring state-based alarming strategies. Moreover, another advanced technique to analyze the interaction between alarms and operator responses is process discovery of operational procedures (Hu et al. 2016c). The results can be used to provide decision supports by analyzing operator actions from historical data.

In addition to the above analytical functions, reporting functions are also useful. Table 3 lists three reporting

functions, including the Bad Actor List, Performance Calculator, and Bad Actor Comparison. A bad actor list contains statistical results of alarm data. It does not only indicate top bad actors, but also tells distributions of alarm priorities, alarm identifiers, and unit areas. Performance Calculator gives results of how many alarms can be reduced by applying delay timers to bad actors and suppressing specified nuisance alarms. Bad Actor Comparison compares the bad actor list of the loaded alarm historian with another one for the same alarm system but at a different time period, thus allowing audit checks to determine if implemented changes have helped.

Table 3. Report Functions in “Alarm Data Analysis”.

Report Function	Task
Bad Actor List	Generate Excel reports of basic statistical information of alarms by top bad actors, alarm identifiers, alarm priorities, and locations.
Performance Calculator	Generate Excel reports of alarm reduction by simulating the implementation of delay-timers and alarm suppression techniques.
Bad Actor Comparison	Generate Excel reports of changes of alarm count for each alarm variable during two different time periods.

#### Alarm Configuration Analysis

This functional part is used to simulate the configuration of alarm systems for univariate process signals, as is the current practice in industry. Techniques, such as filters, delay timers, and deadbands, are provided. Moreover, there are several ways to determine alarm limits. The user can manually define them, set a certain alarm rate, select the maximum or minimum historical value, or make the platform find an optimal limit automatically. The platform then can calculate, display, and compare the design results based on different techniques. The descriptions of these functions for alarm configuration are listed in Table 4.

Filters are used to reduce noises from process signals. As a result, the process data during normal and abnormal situations will be easily separated, which is an effective way to minimize false and missed alarms. Six commonly used industrial filters are provided, including the moving average filter, moving variance filter, moving norm filter, rank order filter, low pass filter, and Exponentially Weighted Moving Average (EWMA) filter. The mathematical principles of these filters can be found in (Izadi et al. 2009; Cheng et al. 2013b). In contrast to filters, delay timers work on alarm signals rather than process signals. Two types of delay timers are provided, namely, the off-delay timer and on-delay timer. The off-delay timer reduces chattering alarms by delaying return-to-normal instants while the on-delay timer reduces chattering alarms or removes fleeting alarms by delaying alarm occurrences.

The principle and design of delay timers can be found in (Adnan et al. 2011; Adnan et al. 2013). Adding a deadband is another widely used technique in industry. This requires two different alarm limits for the raising and clearing of alarms (Adnan et al. 2011). Chattering alarms caused by noise can be effectively reduced by deadbands.

Table 4. Functions in “Alarm Configuration Analysis”.

Function	Task	
Moving Average		
Moving Variance		
Filter	Reduce noises, remove bad data, or modify statistical distributions of process signals.	
Moving Norm		
Rank Order		
Low Pass		
EWMA		
Delay Timer	Off-Delay Timer	Reduce chattering or fleeting alarms by delaying alarm raising or clearing instants.
	On-Delay Timer	
	Deadband	Reduce false or missed alarms by applying different thresholds for alarm raising and clearing.
Alarm Limit Optimization		Optimize high or low alarm limit automatically.

To design the above techniques, three performance specifications are used commonly, including the False Alarm Rate (FAR), Missed Alarm Rate (MAR) and Averaged Alarm Delay (AAD). FAR and MAR measure the accuracy in detecting abnormal situations, and AAD denotes the alarm latency (Adnan et al. 2011; Xu et al. 2012). However, tradeoff exists between FAR and MAR. It is impossible to reduce FAR and MAR simultaneously, by just adjusting the alarm limit. Thus, filters, delay timers, and deadbands can be applied to improve the performance of alarm systems. A Receiver Operating Characteristic (ROC) curve is provided to visualize the tradeoff between FAR and MAR, for the design of alarm systems.

#### Process Data Analysis

This functional module provides a variety of techniques to analyze and visualize process signals from different perspectives of view. Prior to analysis of process data, data preprocessing is usually required. Four commonly used data preprocessing techniques are incorporated in the platform, including data detrending, data smoothing, data normalization, and outlier removal. The descriptions of these data preprocessing functions are listed in Table 5.

The data analytical functions are classified into two groups as listed in Table 6. The analytical functions and visualization plots for univariate process signals include

time trend, frequency spectrum, power spectrum density, and spectrogram, and those for multivariate process signals include high density plots, parallel coordinate plots, scatter matrices, spectral envelopes, and temporal and spectral Principle Components Analysis (PCA and SPCA).

Table 5. Preprocessing Functions for Process Signals.

Function	Task
Detrend Data	Make the mean of the process signals be zero.
Data Smoothing	Remove the noise from process signals using a band filter.
Data Normalization	Normalize process signals.
Remove Outliers	Detect and remove outliers.

Table 6. Functions to Analyze and Visualize Process Signals.

Type	Function
Univariate	Time trend
	Frequency spectrum
	Power spectrum density
	Spectrogram
Multivariate	High density plot
	Parallel coordinate
	Scatter matrix
	Spectral envelope
	PCA and Spectral PCA

Among the univariate plots, the frequency spectrum and power spectrum density are in frequency domain, and the spectrogram is in the time-frequency or wavelet domain. A spectrogram plot is a 2 dimensional colormap that can reflect both the temporal and spectral information simultaneously for a single process variable. High density plots visualize the plots of a multitude of process variables in a compact form, namely, in a single plot. Parallel coordinate plots and scatter matrices are commonly used to visualize multivariate process signals, so that the relations between process variables can be easily observed. PCA is a commonly used technique to analyze large multivariate datasets (Jolliffe 2002). It reduces data dimensionality and distills important information based on the dependencies between process variables. Spectral envelopes (Stoffer 1999; Stoffer et al. 2000) and spectral PCA (Thornhill et al. 2002) are effective in analyzing the spectral behavior of process signals, the results of which could help to diagnose plant oscillations (Jiang et al. 2007, Tangirala et al. 2007). In addition, the platform also provides functions to visualize process signals and their associated alarm signals in a single plot, and to calculate statistical values, such as the mean, median, variance, compression factor, and quantization factor. The latter functions are particularly useful for assessing data quality.

### Connectivity and Causality Analysis

An often overlooked part of analytics is causation analysis. While this information is available in a Piping and Instrumentation Diagrams (P&ID), the connectivity or causality information is not always up to-date and not easily available in mathematical forms. This data-based functional part is used to detect correlations and causal relations between process variables to capture material and information flow paths in the process. Four functions are provided, including the correlation coefficient, spectral correlation, Granger causality, and Transfer Entropy (TE). The calculated correlations and causal relations are visualized using correlation color maps, and Signed Directed Graphs (Yang et al. 2010). Table 7 describes the functionalities and capacities of these functions.

Table 7. Functions in “Connectivity and Causality Analysis”.

Function	Task
Correlation Coefficient	Detect correlations between process signals and visualize the results using a correlation color map.
Spectral Correlation	Detect the correlations between power spectrums of process signals and visualize the results using a correlation color map.
Granger Causality	Detect causal relations between process signals and visualize the results using a signed directed graph. This method is fast, but only effective for linear processes.
Transfer Entropy	Detect causal relations between process signals and visualize the results using a signed directed graph. This method is effective for either linear or nonlinear processes, but quite computational burdensome.

Correlation coefficient is calculated by assuming a certain time lag between two time series. Accordingly, the real correlation between two process variables is achieved as the absolute maximum value of correlation coefficients (Welch 1974; Yang et al. 2012). Spectral correlation is a specific application of correlation coefficient to the power spectrums of process signals (Tangirala et al. 2005). It indicates the similarities in the spectral ‘shapes’ of all signals; for example, this can reveal all process variables that are oscillating at the same frequency.

However, correlation does not indicate a causal relation. The directions of interactions between process variables are usually unknown from correlations. To detect

how process variables influence each other and how abnormalities propagate through processes, causality inference is effective. There are a variety of causality inference techniques based on different resources (Chiang & Braatz 2003; Thambirajah et al. 2009; Jiang et al. 2009; Schlegel et al. 2013; Yang et al. 2014). The techniques, namely, Granger causality and transfer entropy provided in this platform are based on process history. Granger causality was first proposed by Granger in 1969, based on two assumptions: (1) the cause occurs before the effect; (2) the cause contains information about the effect that is unique (Granger 1969). However, this method only works for linear processes. By contrast, the transfer entropy method is effective for both linear and nonlinear processes (Schreiber 2000; Kaiser & Schreiber 2002; Bauer et al. 2007). Furthermore, Direct Transfer Entropy (DTE) can be used to find direct dependencies between process variables (Duan et al. 2013). To circumvent the assumptions of stationary processes and Gaussian distributions, a Transfer Entropy (T0E) was proposed (Nair 2013; Duan et al. 2015).

### Case Studies for Alarm Data Analytics

This section illustrates the application of alarm data analytics of the smart platform based on case studies involving real industrial A&E data sets.

#### Analysis of Bad Actors and Removal of Nuisance Alarms

The alarm data used in this case study was collected from an oil plant over a time period of 10 days. Totally, 173 unique alarms were found to occur with an average of 8.5 alarms over a 10 minutes period, which was much higher than the benchmark threshold of an efficient alarm system, namely, 1 alarm over 10 minutes. To explore why this alarm system had such a high alarm rate over the selected time period, the alarm data analytical functions of this smart platform are applied.

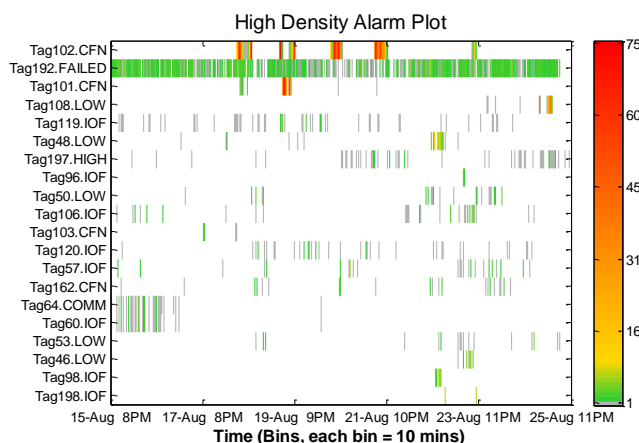

Figure 5. High density alarm plot.

Figure 5 shows a high density alarm plot of the top 20 bad actors over the selected time period of 10 days. This figure contains 864,000 bits of alarm data for each of

20 tags. The color bar denotes the number of alarms in each 10 min time bin. The red and orange colors indicate high alarm rates, implying chattering or repeating alarms. It is obvious that “Tag102.CFN” and “Tag101.CFN” were likely chattering over some short time periods, and “Tag192.FAILED” kept repeating for the whole time period. Moreover, it can be seen that two alarms, “Tag64.COMM” and “Tag60.IOF”, were announced almost simultaneously in the first two days of the selected time period. Around 11pm on Aug. 23<sup>rd</sup>, there was a high chance that most top bad actors occurred, implying a plant upset around this time instant.

Figure 6 shows an alarm similarity color map of the top 20 bad actors. Alarm tags are clustered based on their correlations. The darker color of a block indicates a higher correlation between alarms. The diagonal of the map consists of 1’s (black squares), indicating the highest correlations of alarm tags with themselves. In this case study, only one pair of alarms was found to be correlated, namely, “Tag64.COMM” and “Tag60.IOF”. The correlation value was 0.9, indicating a strong relation.

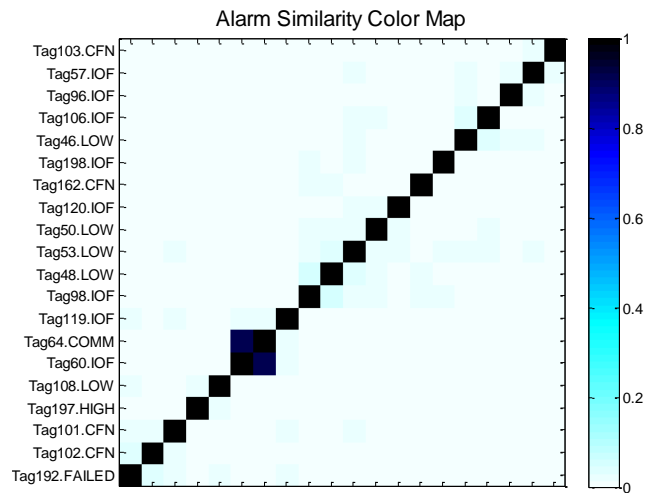

Figure 6. Alarm similarity color map.

Figure 7 displays the chattering indices of the top 20 bad actors using red bars. The green line denotes the threshold of chattering alarms based on ANSI/ISA-18.2 (2009) standard (no more than 3 alarms over a 60 second period). Any chattering index that exceeds this threshold indicates a chattering alarm. Among these bad actors, 7 alarms were determined to have chattering problems. To design delay timers for these chattering alarms, the run length distribution is used. Figure 8 shows an example of designing off-delay timer for the topmost bad actor “Tag102.CFN”. The red curve indicates the alarm count that can be reduced by implementing an off-delay timer with the value of the delay timer on the horizontal axis. For instance, an off-delay timer of 10 sec reduces 82% of the alarm occurrences. The off-delay timer turns the chattering alarms into standing alarms. Accordingly, the alarm count was reduced from 4856 to 875 over 10 days.

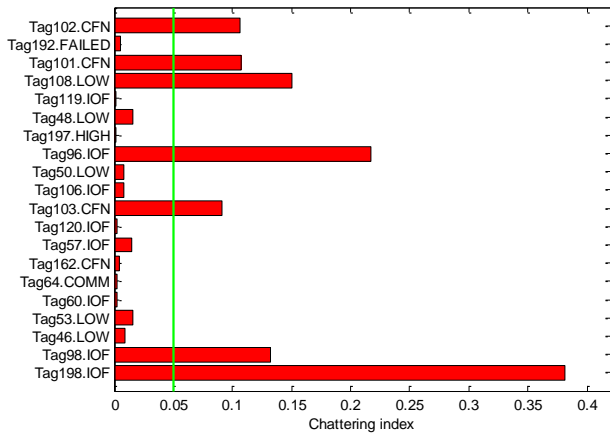

Figure 7. Chattering indices of top bad actors.

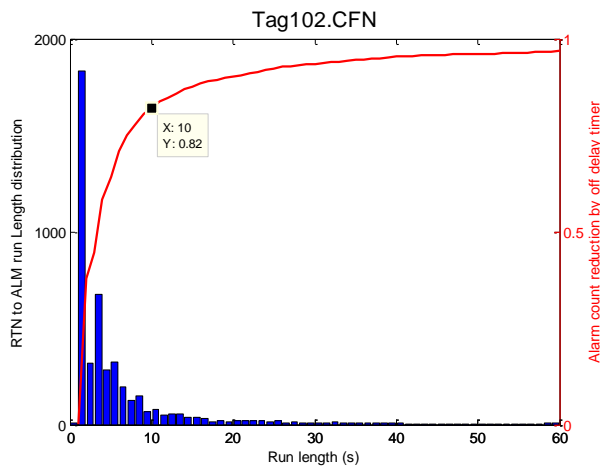

Figure 8. Design of off-delay timer based on the run length distribution.

In the same manner, the types and values of delay timers were recommended for all the seven chattering alarm tags as shown in Table 8. It is noteworthy that small off-delay timers were very effective in reducing most chattering instants for these alarm tags. By applying the recommended off-delay timers, the average alarm rate can be reduced to 4.7 alarms over 10 minutes, which is 45% lower than the original alarm rate, namely, 8.5 alarms per 10 minutes.

Table 8. Recommendations for setting of delay timers.

Alarm Tag	Type of delay-timer	Length of delay-timer(sec)	No. of alarms reduced	Percentage of alarms reduced
Tag102.CFN	Off-delay	10	3981	82%
Tag101.CFN	Off-delay	10	856	79%
Tag108.LOW	Off-delay	10	408	77%
Tag96.IOF	Off-delay	8	156	91%
Tag103.CFN	Off-delay	8	141	96%
Tag98.IOF	Off-delay	10	65	73%
Tag198.IOF	Off-delay	2	76	87%

### Identification, Comparison and Clustering of Alarm Floods

This subsection illustrates the functions of alarm flood analysis, including the identification, comparison, and clustering of alarm floods. The same alarm data set in the previous subsection is used here. Based on benchmark thresholds of occurrence and clearing of an alarm flood (ISA-18.2 2009; EEMUA-191 2013; IEC 2014), alarm floods were easily identified using an alarm burst plot shown in Figure 9. The black line indicates the threshold of identifying the occurrence of an alarm flood, namely 10 alarms over 10 minutes. The alarm floods are highlighted by blue blocks. It can be seen that this plant was in the alarm flood situation for a considerable time period.

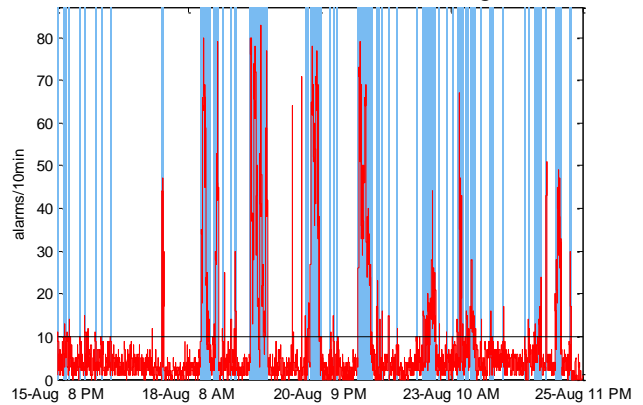

Figure 9. Alarm burst plot for raw alarm data.

Figure 10 shows the alarm burst plot for the alarm data with chattering alarms reduced using a uniform off-delay-timer (40 sec) applied to all alarm tags. It can be seen that significant reduction was achieved by applying the off-delay-timer. Originally, there were 66 alarm floods in Figure 9 and they occurred for almost 25.4% of the entire time period of 10 days. After applying the off-delay timer, there were only 38 alarm floods left and they occurred during 6.4% of this time period. Having removed the chattering alarms, these alarm floods can be considered as true alarm floods, requiring further analysis, so as to prevent the occurrence of the same root cause.

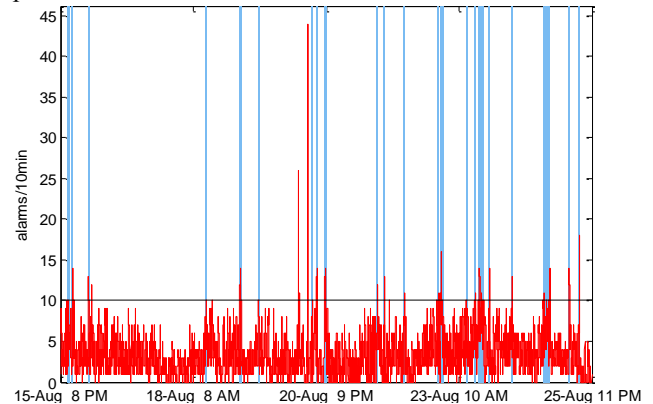

Figure 10. Alarm burst plot for alarm data with chattering alarms reduced.



To detect frequent alarm sequences of the 38 alarm floods, sequence alignment algorithms are used. The similarity indices for all pairs of alarm floods are calculated and shown as a similarity color map in Figure 11, where similar alarm floods are clustered. The vertical and horizontal axes display the event number of the 38 alarm floods. A smaller event number index refers to an earlier occurrence in time. The color bar at the right side of the cluster map indicates the strength of similarity indices. The diagonal of the color map represents the similarity between each alarm flood event and itself, and is naturally 1.

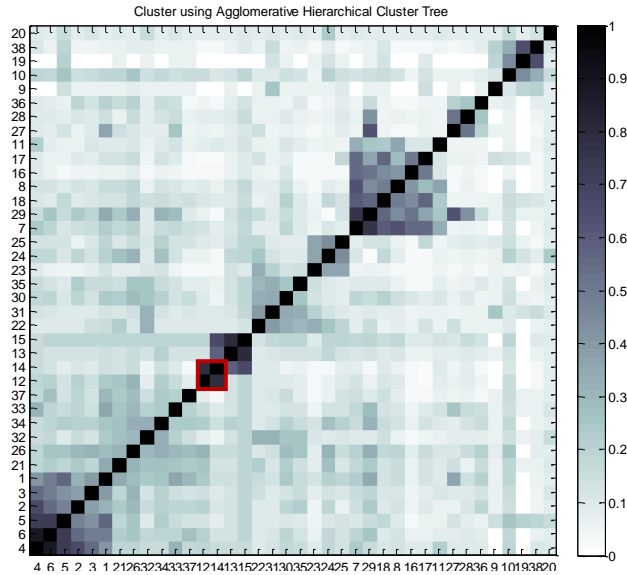

Figure 11. Similarity color map of clustered alarm floods.

To show how similar alarm floods resemble each other, an example is given in Figure 12. The No. 12 and No. 14 alarm floods (as highlighted in the red rectangle in Figure 11) were found to be very similar. Figure 12 presents the sequence alignment between the two alarm floods. It can be seen that they share a long sequence of common alarms. According to their time stamps, this may indicate that the abnormality causing No. 12 alarm flood had not been well solved, and thus appeared again in the afternoon of the same day, causing No. 14 alarm flood.

### Causality Inference Using Alarm Data

This subsection illustrates the alarm data based causality inference technique. The alarm data was collected from a hydrogen plant over 3.5 days. Totally, 288 unique alarms were found from the A&E log. The causal relations between each pair of alarms are detected by applying the TE based causality inference. Six alarm signals are selected to demonstrate the causality inference technique. The historical data samples of the six alarm tags are shown in Figure 13. Over the selected time period, the six alarm signals were annunciated 653, 242, 242, 242, 219, and 106 times, respectively. More detailed results of this case study appear in (Hu et al. 2016b).

No 12 Alarm Flood		No 14 Alarm Flood	
08:59:37 20-Aug	Tag19.LOLO	Tag19.LOLO	13:22:29 20-Aug
08:59:37 20-Aug	Tag205.LOW	Tag205.LOW	13:22:29 20-Aug
08:59:37 20-Aug	Tag205.LOLO	Tag205.LOLO	13:22:29 20-Aug
08:59:37 20-Aug	Tag16.LOW	Tag16.LOLO	13:22:29 20-Aug
08:59:37 20-Aug	Tag16.LOLO	Tag17.LOW	13:22:29 20-Aug
08:59:37 20-Aug	Tag17.LOW	Tag17.LOLO	13:22:29 20-Aug
08:59:37 20-Aug	Tag17.LOLO	Tag9.LOLO	13:22:29 20-Aug
08:59:37 20-Aug	Tag9.LOW	Tag4.LOW	13:22:29 20-Aug
08:59:37 20-Aug	Tag9.LOLO	Tag4.LOLO	13:22:29 20-Aug
08:59:37 20-Aug	Tag4.LOW	Tag5.LOW	13:22:29 20-Aug
08:59:37 20-Aug	Tag4.LOLO	Tag5.LOLO	13:22:29 20-Aug
08:59:37 20-Aug	Tag5.LOW	Tag6.LOW	13:22:29 20-Aug
08:59:37 20-Aug	Tag5.LOLO	Tag6.LOLO	13:22:29 20-Aug
08:59:37 20-Aug	Tag6.LOW	Tag200.LOLO	13:22:29 20-Aug
08:59:37 20-Aug	Tag6.LOLO	Tag201.LOW	13:22:29 20-Aug
08:59:37 20-Aug	Tag200.LOW	Tag201.LOLO	13:22:29 20-Aug
08:59:37 20-Aug	Tag200.LOLO	Tag94.LOW	13:22:29 20-Aug
08:59:37 20-Aug	Tag201.LOW	Tag94.LOLO	13:22:29 20-Aug
08:59:37 20-Aug	Tag201.LOLO	Tag152.LOW	13:22:29 20-Aug
08:59:37 20-Aug	Tag94.LOW	Tag152.LOLO	13:22:29 20-Aug
08:59:37 20-Aug	Tag94.LOLO	Tag202.LOW	13:22:30 20-Aug
08:59:37 20-Aug	Tag152.LOW	Tag202.LOLO	13:22:30 20-Aug
08:59:37 20-Aug	Tag152.LOLO	Tag203.LOW	13:22:30 20-Aug
08:59:37 20-Aug	Tag202.LOW	Tag203.LOLO	13:22:30 20-Aug
08:59:37 20-Aug	Tag202.LOLO	Tag138.LOW	13:22:30 20-Aug
08:59:38 20-Aug	Tag203.LOW	Tag138.LOLO	13:22:30 20-Aug
08:59:38 20-Aug	Tag203.LOLO	Tag8.HIGH	13:22:30 20-Aug
08:59:38 20-Aug	Tag138.LOW	Tag18.HIGH	13:22:30 20-Aug
08:59:38 20-Aug	Tag138.LOLO	Tag16.HIGH	13:22:30 20-Aug
08:59:38 20-Aug	Tag8.HIGH	Tag17.HIGH	13:22:30 20-Aug
08:59:38 20-Aug	Tag16.HIGH	Tag201.HIGH	13:22:30 20-Aug
08:59:38 20-Aug	Tag17.HIGH	Tag152.HIGH	13:22:30 20-Aug
08:59:38 20-Aug	Tag201.HIGH	Tag138.HIGH	13:22:31 20-Aug
08:59:38 20-Aug	Tag152.HIGH	Tag18.LOW	13:23:28 20-Aug
08:59:39 20-Aug	Tag138.HIGH	Tag19.LOW	13:23:28 20-Aug
09:00:36 20-Aug	Tag18.LOW	Tag16.LOW	13:23:28 20-Aug
09:00:36 20-Aug	Tag19.LOW	Tag9.LOW	13:23:28 20-Aug
09:00:36 20-Aug	Tag200.LOW	Tag200.LOW	13:23:28 20-Aug
09:00:37 20-Aug	Tag9.LOW		

Figure 12. Sequence alignment between two similar alarm flood sequences.

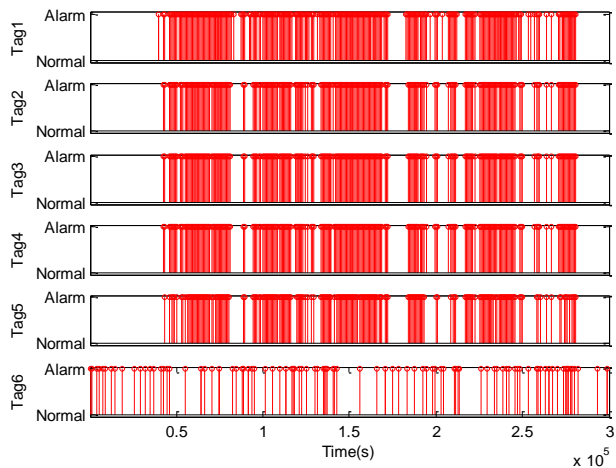

Figure 13. Alarm signals over 3.5 days.

By setting a maximum value of the time lag (100 sec in this case study), the Normalized Transfer Entropies (NTEs) under different time delays between each pair of alarm signals were calculated and shown in Figure 14. The

maximum values of NTEs are regarded as the causal strengths.

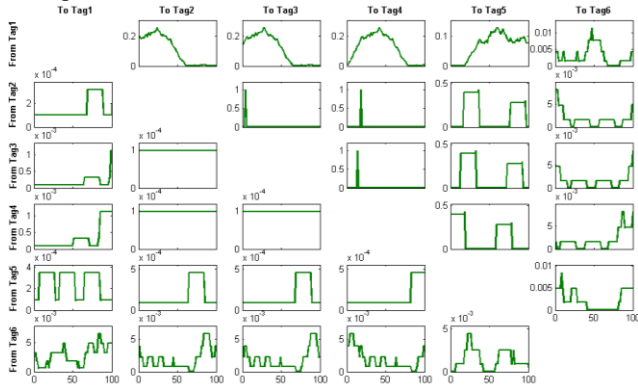

Figure 14. Trends of transfer entropies versus time lags.

Meanwhile, significance thresholds are calculated from Monte Carlo tests using the method in (Hu et al. 2016b). The maximum NTEs and their corresponding significance thresholds (in brackets) are given in Table 9.

Table 9. Maximum NTEs and significance thresholds.

	Tag1	Tag2	Tag3	Tag4	Tag5	Tag6
Tag1		0.258 (0.016)	0.258 (0.015)	0.258 (0.016)	0.129 (0.015)	0.012 (0.022)
Tag2	0.0003 (0.013)		1 (0.001)	1 (0.001)	0.434 (0.014)	0.008 (0.019)
Tag3	0.001 (0.013)	0.0001 (0.014)		1 (0.001)	0.434 (0.014)	0.008 (0.018)
Tag4	0.0011 (0.013)	0.0001 (0.014)	0.0001 (0.014)		0.434 (0.014)	0.008 (0.020)
Tag5	0.0004 (0.012)	0.0004 (0.013)	0.0005 (0.013)	0.0005 (0.013)		0.009 (0.017)
Tag6	0.007 (0.009)	0.006 (0.009)	0.006 (0.009)	0.006 (0.009)	0.005 (0.010)	

Based on Table 9, the causal relations are found between alarms with NTEs larger than the significance thresholds. As a result, a causal map describing the information flow paths is drawn in Figure 15.

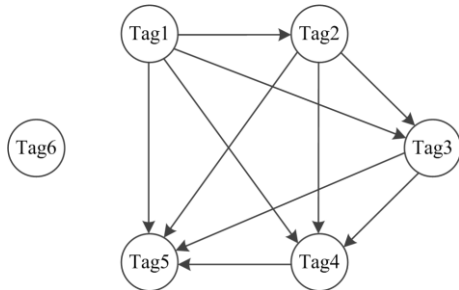

Figure 15. Causal map of information flow paths.

Causal relations between two variables can be direct or indirect if mediated by an intermediate variable. It is therefore important to be able to differentiate between such relations as has been done in (Hu et al. 2016b). The Normalized Direct Transfer Entropies (NDTEs) are calculated for alarm pairs with causal relations in Figure 15. By comparing the NDTEs with the corresponding

significance thresholds, indirect causalities are found and excluded. Accordingly, a causal map describing all direct information flow paths is shown in Figure 16. This conclusion is consistent with the process knowledge presented in (Hu et al. 2016b).

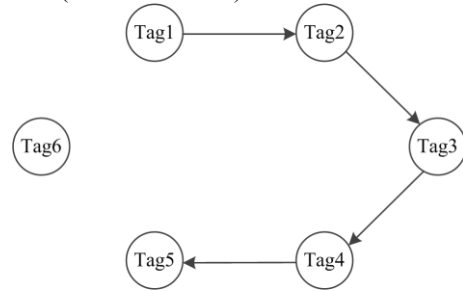

Figure 16. Causal map of direct information flow paths.

### Case Studies for Alarm Configuration Analysis

This section illustrates the techniques for the design of univariate alarm systems in the functional part “Alarm Configuration Analysis” of the smart platform. An example is given based on the process signal shown in Figure 17. In the foremost step, the normal and abnormal parts of the process signal are specified as the blue and red sections in Figure 17.

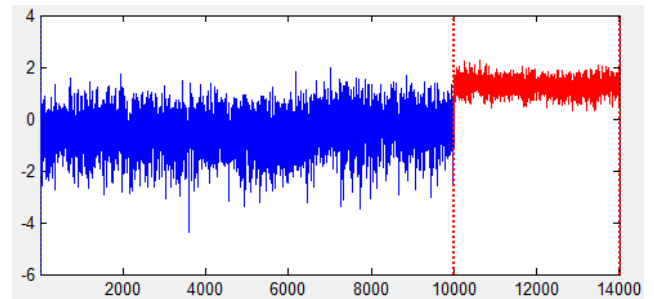

Figure 17. Normal (blue) and abnormal (red) parts of a process signal.

Assuming the original high alarm limit to be 1 (HAL =1), alarms are generated as the vertical red lines in the left plot of Figure 18. The distributions of normal data and abnormal data are shown in the right plot of Figure 18. As a result, there are 793 alarm occurrences. The FAR and MAR rates are 1.22% and 14.36%, respectively.

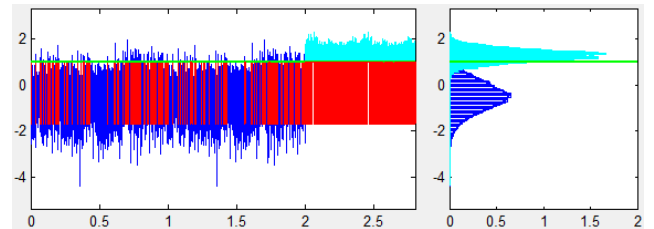

Figure 18. Original setting with HAL=1.

In the first design scenario, the high alarm limit is redesigned using an optimization function. The optimal alarm limit for this process signal is 0.72. The alarm signal

is generated and shown in the left plot of Figure 19. As a result, the number of alarm occurrences is reduced to 579. The FAR and MAR rates are 3.00% and 1.80%. Compared with the original setting, the FAR rate is increased slightly while the MAR is reduced significantly.

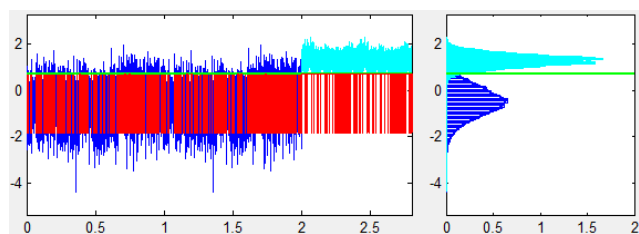

Figure 19. Design scenario with an optimized alarm limit.

In the second design scenario, an off delay timer of 7 samples is used based on the original setting (HAL=1). This off-delay timer is very effective in reducing chattering alarms. The alarm signal with chattering alarms reduced is shown in the left plot of Figure 20. It can be seen that there is almost no alarm occurrence in the abnormal part of the process signal. The total number of alarm occurrences is reduced to 183. The MAR decreases to 0.03%, which is a significant reduction compared to the original setting. However, the FAR grows to 6.69% at the same time.

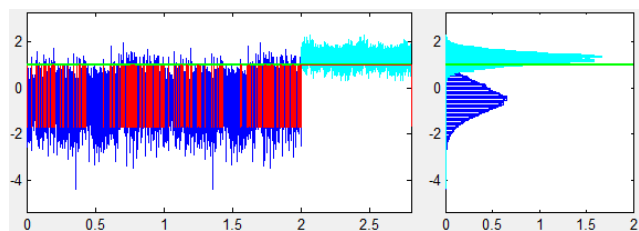

Figure 20. Design scenario with an off-delay timer.

In the third design scenario, a moving average filter of 10 samples is used. Compared with the original setting and the previous design scenarios, the normal and abnormal parts of the process signal are more separated, as shown in the right plot of Figure 21. With the original alarm limit (HAL=1), there are only 35 alarm occurrences in Figure 21. The FAR and MAR are 0 and 1.77%, respectively. The two metrics are much lower than those in the original setting.

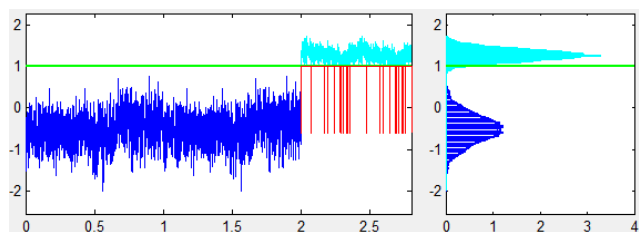

Figure 21. Design scenario with a moving average filter.

To visualize the tradeoff between FAR and MAR in the design of alarm system, a ROC curve is drawn in Figure 22. The dark and light blue curves are the ROC

curves for the design scenario with a filter and the original setting. The high alarm limits for the two cases are set the same. It is obvious that the ROC based on the application of a filter is much closer to the origin, indicating better alarm system design.

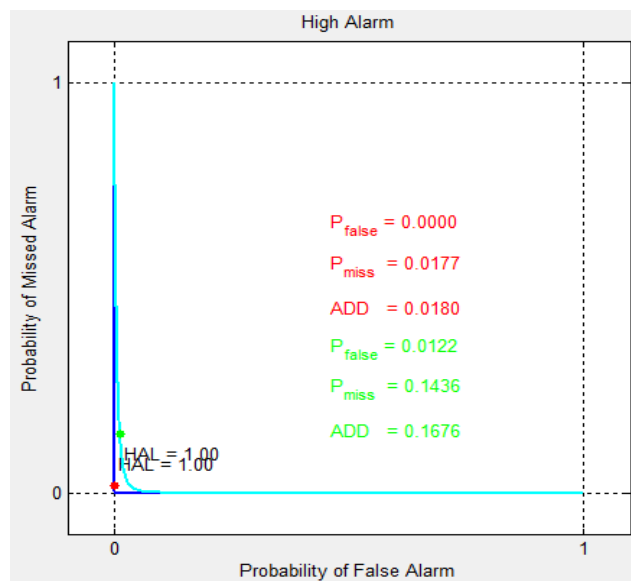

Figure 22. ROC curves.

## Case Studies for Process Data Analytics

This section illustrates the application of process data analytics of this smart platform using case studies involving real industrial process data.

### Detection of root cause of plant-wide oscillations

This subsection considers the application of fusing process data and process connectivity information to detect and locate the root-cause of plant-wide oscillations using process data analytical methods.

Detection and diagnosis of plant-wide disturbances is an important issue in many process industries (Qin 1998, Desborough & Miller 2001). Thornhill and HÅagglund (1997) used zero-crossings of the control error signal to calculate integral absolute error (IAE) in order to detect oscillations in a control loop. This method has poor performance in the cases of noisy error signals. Miao and Seborg (1999) suggested a method based on the auto-correlation function to detect excessively oscillatory feedback loops. The auto-covariance function (ACF) of a signal was utilized in Thornhill et al. (2003a) to detect oscillation(s) present in a signal. This method needs a minimum of five cycles in the auto-covariance function to detect oscillation, which is often hard to obtain, particularly in the case of long oscillations (e.g., an oscillation with a period of 400 samples). Although the data set can be down sampled, down sampling may introduce aliasing in the data. Thornhill et al. (2002) have also proposed Spectral Principal Component Analysis (SPCA) to detect oscillations and categorize the variables

having similar oscillations. This method does not provide any diagnosis of the root cause of the oscillations which is generally the main objective of the exercise.

A more efficient procedure based on the spectral envelope method for detection and diagnosis of plant-wide oscillations was proposed by Jiang et al. (2007). The spectral envelope method is a frequency domain technique that was originally introduced by Stoffer et al. (1993) to explore the periodic nature in time series. The idea is to assign numerical values to each of the categories followed by a spectral analysis of the resulting discrete-valued time series. Later McDougall et al. (1997) extended the concept of spectral envelope to real-valued series. In exploring the periodic nature of a real-valued series, one can do spectral analysis of not only the original series, but also transformed series. The key idea in McDougall et al. (1997) was to select optimal transformations of a real-valued series that emphasize any periodic nature in the frequency domain.

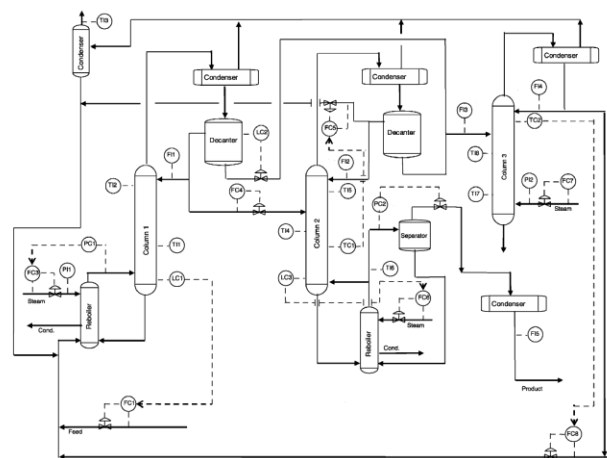

Figure 23. P&ID of the distillation plant of Eastman Chemical Company.

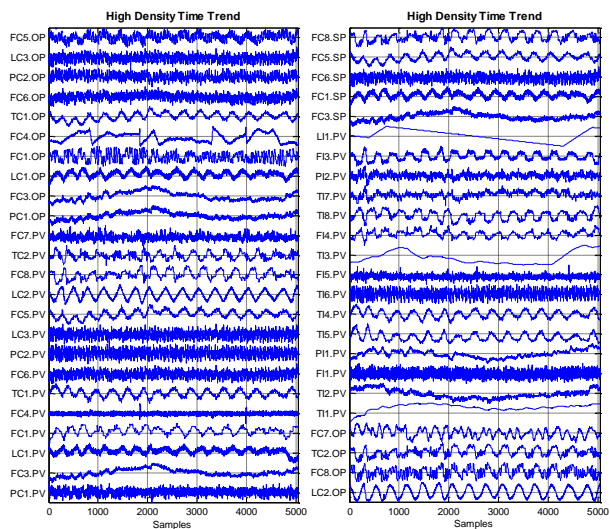

Figure 24. High density time trends.

In this case study, the process data was collected from a distillation plant of Eastman Chemical Company, USA

(Thornhill et al. 2003b). The Piping and Instrumentation Diagram (P&ID) of this plant is shown in Figure 23. The collected data has 48 process variables and 5040 observations sampled at the 20 sec interval. The high density plots of time trends and power spectra of these process variables are shown in Figures 24 and 25, respectively. It can be seen from Figure 25 that many peaks appear in the power spectra, which indicates the presence and propagation of plant-wide oscillations in many variables.

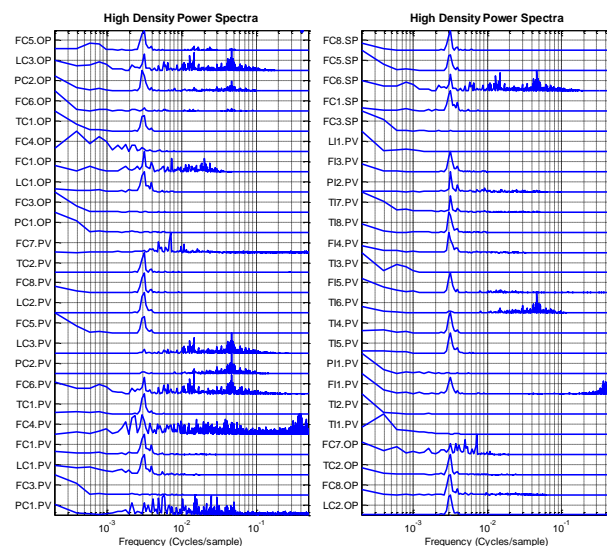

Figure 25. High density power spectra.

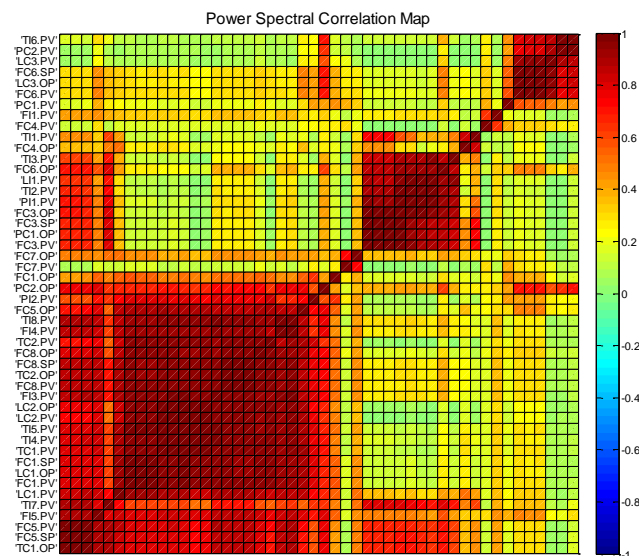

Figure 26. Power spectral correlation map.

To analyze plant oscillations, the power spectral correlations are first calculated and shown as a power spectral correlation color map in Figure 26, where process variables with similar power spectra are clustered. The color bar on the right side of the color map indicates the strength of correlation. The red and orange colors indicate strong correlations and the green color indicates a weak correlation. The diagonal of the color map represents the

correlation between one variable and itself. Based on Figure 26, it is easy to identify all process variables that share the same oscillating feature. These would include Process Variables (PVs) as well as the corresponding Manipulative Variables (MVs). If necessary, the MVs can be omitted to obtain a short-list of all oscillating PVs.

In this case study the spectral envelope method is used to diagnose the plant oscillation. Figure 27 shows the calculated spectral envelope, where a clear peak is observed at the frequency of 0.003175 cycles per sample, which was the frequency of concern for plant engineers.

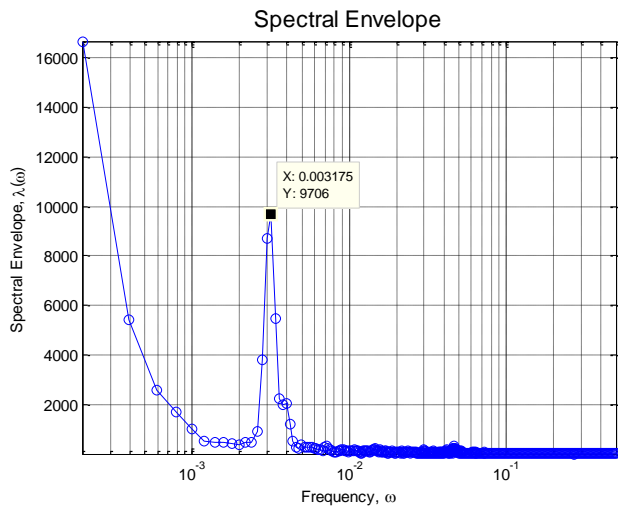

Figure 27. Spectral envelope.

The Chi-squared test statistics of the 48 process variables at the oscillation frequency of 0.003175 cycles per sample are calculated and shown using a bar chart in Figure 28. The red dashed line denotes the significance threshold of 13.82 at the significance level of 0.001. As a result, the process variables with Chi-squared values larger than this threshold are identified to be oscillating at the frequency of 0.003175 cycles per sample.

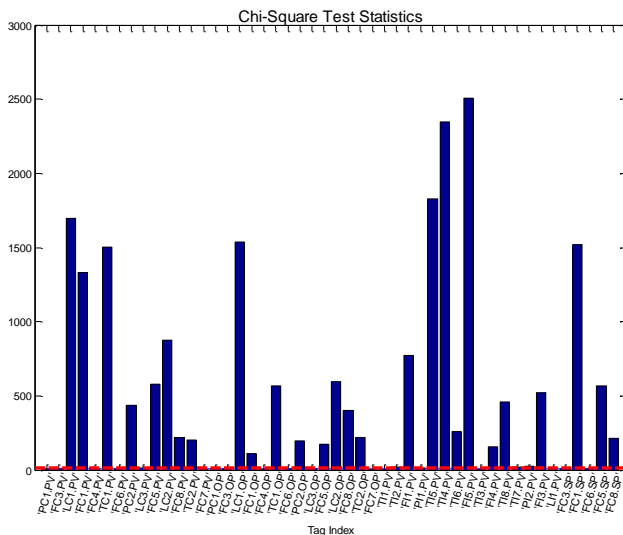

Figure 28. Chi-squared test statistics.

Figure 29 shows the Oscillation Contribution Indices (OCIs) of the 48 process variables at the oscillation

frequency of 0.003175 cycles per sample. The red dashed line denotes the OCI threshold of 1. Variables that have OCIs larger than 1 are regarded as root cause candidates. Among these variables, “LC2.PV” and “LC2.OP” have the largest OCIs, indicating the loop associated to tag “LC2” contributes most to the spectral envelope at the frequency of 0.003175 cycles per sample. Thus, this particular loop should be examined as the first root cause candidate.

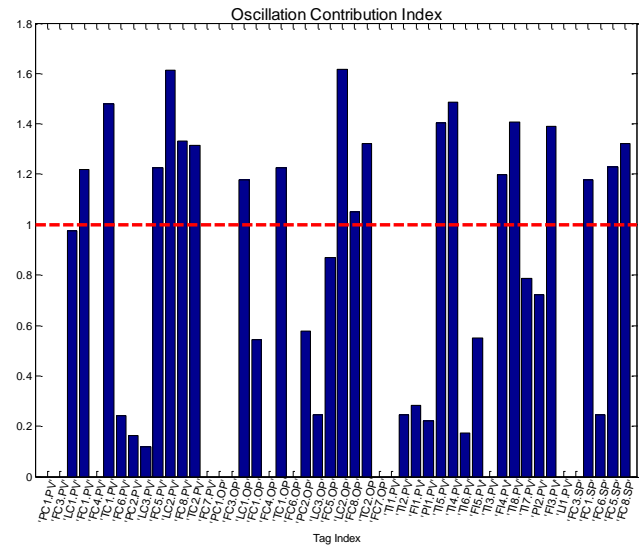

Figure 29. Oscillation contribution indices.

Figure 30 shows the scatter plot between “LC2.PV” and “LC2.OP”. The elliptical pattern indicates a valve stiction, that caused limit cycles in the loop and then propagated to many other variables. Based on a plant test, there indeed existed a 4% stiction in the valve. Thus, this was exactly the root-cause of the plant-wide oscillations. This root cause was also validated by the connectivity analysis (Jiang et al. 2009).

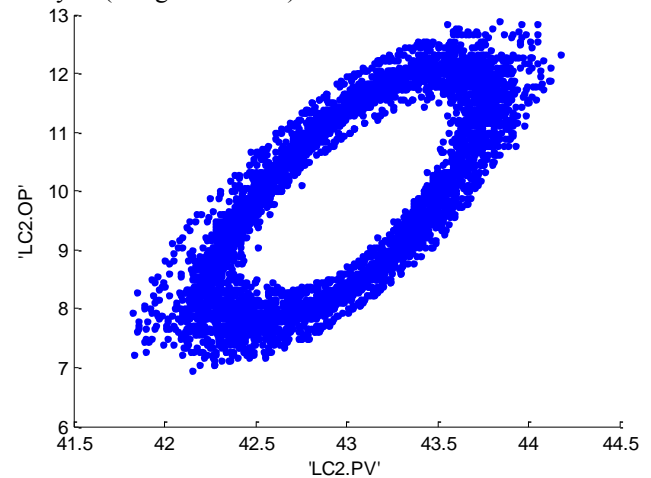

Figure 30. Scatter plot between “LC2.PV” and “LC2.OP”.

### Process Connectivity Analysis

This subsection illustrates root cause diagnosis of plant-wide oscillations based on process connectivity



threshold as 0.02, the causal relations are found as those with NTEs larger than 0.02 (Duan et al. 2013). As a result, the information flow paths are identified and represented using a signed directed graph in Figure 36. This figure also includes bidirectional connectivity as detected by the application of transfer entropy method. In many cases, bidirectional connectivity is due to the presence of material flow paths as well as feedback control loops.

Table 10. NTEs between process variables.

	$y_1$	$y_2$	$y_3$	$y_4$	$y_5$
$y_1$		0.001	0.089	0.177	0.014
$y_2$	0.131		0.117	0.154	0.010
$y_3$	0.078	0.005		0.008	0.105
$y_4$	0.128	0.005	0.095		0.019
$y_5$	0.016	0.001	0.130	0.012	

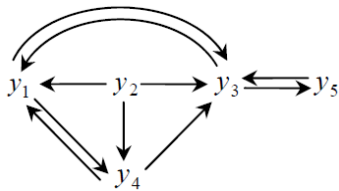

Figure 36. Information flow paths based on NTEs.

It is also important to know if the detected causal relations are direct or indirect. To achieve this, the NDTEs are calculated step by step. For example, in the first step, the NDTE from  $y_1$  to  $y_3$  based on  $y_2$  and  $y_4$  is calculated to be 0.024 in Table 11. The value is small, indicating no direct causality from  $y_1$  to  $y_3$ . Thus, the path from  $y_1$  to  $y_3$  is pruned in step 1 in Figure 37. Analogously, other indirect causalities are confirmed. In this case the causality from  $y_2$  to  $y_1$  is confirmed to be direct.

Table 11. NDTE between each pair of process variables with causal relations.

Step	Relation	Intermediate variables	NDTE
1	$y_1 \rightarrow y_3$	$y_2, y_4$	0.024
2	$y_3 \rightarrow y_1$	$y_2, y_4$	0.023
3	$y_2 \rightarrow y_1$	$y_4$	0.425
4	$y_2 \rightarrow y_4$	$y_1$	0.025
5	$y_2 \rightarrow y_3$	$y_1, y_4$	0.021

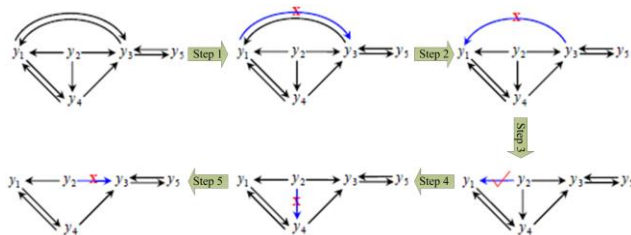

Figure 37. Exclusion of the indirect causalities based on the calculation of NDTEs.

Eventually, the direct information flow paths are detected and shown as a signed directed graph in Figure 38. The result is confirmed to be correct according to (Duan et al. 2013). By highlighting these information flow paths in Figure 39, it is clear how the process variables affect each other. Based on this, the propagation of abnormalities can be easily identified. The red arrows in Figure 38 correspond to feedback loops as validated in Figure 39.

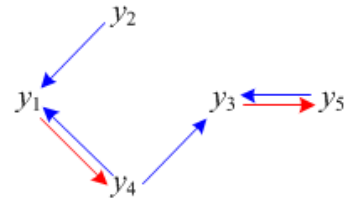

Figure 38. Direct Information flow paths based on NDTEs in Table 11.

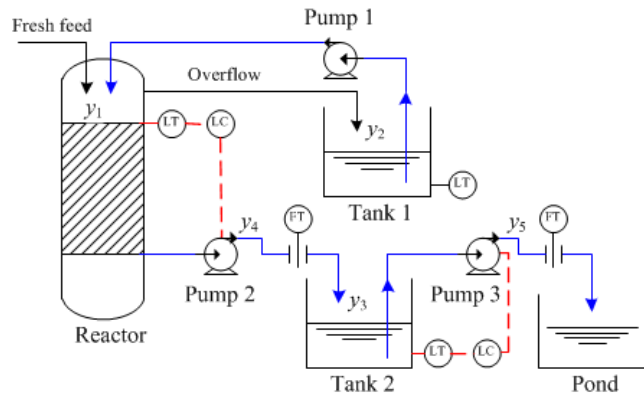

Figure 39. Information flow paths in the FGD process.

## Conclusions

To improve process monitoring and alarm management in process industries, a smart platform for the alarm and process data analytics has been developed. The smart platform consists of a “Data Loading” section and four functional modules. Specifically, “Alarm Data Analysis” helps to detect and remove nuisance alarms, identify and cluster alarm floods, discover causal relations, and find mode-dependent alarms. “Alarm Configuration Analysis” provides a variety of techniques for design of better alarm systems. “Process Data Analysis” analyzes and visualizes the process data from different perspectives. “Connectivity & Causality Analysis” uncovers causal relations between process variables. This paper has introduced the major features in each functional module of the platform, and illustrates the effectiveness and practicability of these features using case studies involving real industrial data. According to the application results, this framework has illustrated the value in fusing information from disparate data sources and in this respect

the proposed platform is comprehensive in functionalities and powerful in providing insightful conclusions.

The development of new features is ongoing so as to enhance the practical utility of the smart platform. One promising future work is the process discovery of operator actions in response to alarm notifications. The pattern extracted from the A&E log is supposed to provide decision support for operators. A preliminary work can be found in (Hu et al. 2016c). Another promising direction is the root cause analysis of alarm floods. In alarm flood situations, operators may fail to identify the root causes and miss the critical alarms, which is the main reason of many accidents (Wang et al. 2016). Thus, if the root causes of alarm floods can be quickly identified in an on-line manner then the operator would be able to confidently handle critical alarms and make correct responses.

## References

- Adnan, N.A., Izadi, I., & Chen, T. (2011). On expected detection delays for alarm systems with deadbands and delay-timers. *Journal of Process Control*, 21, 1318-1331.
- Adnan, N.A., Cheng, Y., Izadi, I., & Chen, T. (2013). Study of generalized delay-timers in alarm configuration. *Journal of Process Control*, 23(3), 382-395.
- Ahmed, K., Izadi, I., Chen, T., Joe, D., & Burton, T. (2013). Similarity analysis of industrial alarm flood data. *IEEE Transactions on Automation Science and Engineering*, 10, 452-457.
- Altschul, S. F., Gish, W., Miller, W., Myers, E. W., & Lipman, D. J. (1990). Basic local alignment search tool. *Journal of Molecular Biology*, 215, 403-410.
- Bauer, M., Cox, J. W., Caveness, M. H., Downs, J. J., & Thornhill, N. F. (2007). Finding the direction of disturbance propagation in a chemical process using transfer entropy. *IEEE Trans. Control Systems Technology*, 15(1), 12-21.
- Beebe, D., Ferrer, S., & Logerot, D. (2013). The connection of peak alarm rates to plant incidents and what you can do to minimize. *Process Safety Progress*, 32(1), 72-77.
- Cheng, Y., Izadi, I., & Chen, T. (2013a). Pattern matching of alarm flood sequences by a modified Smith-Waterman algorithm. *Chemical Engineering Research and Design*, 91, 1085-1094.
- Cheng, Y., Izadi, I., & Chen, T. (2013b). Optimal alarm signal processing: filter design and performance analysis. *IEEE Transactions on Automation Science and Engineering*, 10, 446-451.
- Cheng, Y. (2013). *Data-driven Techniques on Alarm System Analysis and Improvement*. Doctoral Thesis, University of Alberta.
- Chiang, L. H., & Braatz, R. D. (2003). Process monitoring using causal map and multivariate statistics: fault detection and identification. *Chemometrics and Intelligent Laboratory Systems*, 65(2), 159-178.
- Desborough, L. and R. Miller (2001). Increasing customer value of industrial control performance monitoring - honeywell's experience. In *Proc. of CPC VI. Tuscon, Arizona*. 172-192.
- Duan, P., Yang, F., Chen, T., & Shah, S. L. (2013). Direct causality detection via the transfer entropy approach. *IEEE Trans. Control Systems Technology*, 21(6), 2052-2066.
- Duan, P., Yang, F., Shah, S.L., & Chen, T. (2015). Transfer zero-entropy and its application for capturing cause and effect relationship between variables. *IEEE Trans. Control Systems Technology*, 23(3), 855-867.
- EEMUA (Engineering Equipment and Materials Users' Association) (2013). *Alarm Systems: A Guide to Design, Management and Procurement*, Edition 3. London: EEMUA Publication 191.
- Granger, C. W. (1969). Investigating causal relations by econometric models and cross-spectral methods. *Econometrica: Journal of the Econometric Society*, 424-438.
- Hollifield, B., & Habibi, E. (2011). *Alarm Management: A Comprehensive Guide*. Research Triangle Park, NC: ISA.
- Hu, W., Wang, J., & Chen, T. (2015). A new method to detect and quantify correlated alarms with occurrence delays. *Computers & Chemical Engineering*, 80, 189-198.
- Hu, W., Wang, J., & Chen, T. (2016a). A local alignment approach to similarity analysis of industrial alarm flood sequences. *Control Engineering Practice*, 55, 13-25
- Hu, W., Wang, J., Chen, T., & Shah, S. L. (2016b). Cause and effect analysis of industrial alarm signals using modified transfer entropies. *Control Engineering Practice*, under review.
- Hu, W., Ahmad W. A., Chen, T., & Shah, S. L. (2016c). Process discovery of operator actions in response to univariate alarms. In *DYCOPS-CAB2016*, 1026-1031.
- IEC (International Electrotechnical Commission) (2014). *Management of Alarm Systems for the Process Industries*. IEC 62682.
- ISA (International Society of Automation) (2009). *Management of Alarm Systems for the Process Industries*. North Carolina: ISA 18.02.
- Izadi, I., Shah, S.L., Shook, D. S., Kondaveeti, S.R., & Chen, T. (2009). A Framework for Optimal Design of Alarm Systems. In *proceedings of the 7th IFAC SAFEPROCESS*, Barcelona, Spain.
- Izadi, I., Shah, S. L., & Chen, T. (2010). Effective resource utilization for alarm management. *The 49th IEEE Conference on Decision and Control (CDC2010)*, 6803-6808.
- Jiang, H., Patwardhan, R., & Shah, S. L. (2009). Root cause diagnosis of plant-wide oscillations using the concept of adjacency matrix. *J. Process Control*, 19(8), 1347-1354.
- Jiang, H., Choudhury, M. S., & Shah, S. L. (2007). Detection and diagnosis of plant-wide oscillations from industrial data using the spectral envelope method. *J. Process Control*, 17(2), 143-155.
- Jolliffe, I. (2002). *Principal component analysis*. John Wiley & Sons, Ltd.
- Kaiser, A., & Schreiber, T. (2002). Information transfer in continuous processes. *Physica D: Nonlinear Phenomena*, 166(1), 43-62.
- Kondaveeti, S.R., Izadi, I., Shah, S.L., Black, T., & Chen, T. (2012). Graphical tools for routine assessment of industrial alarm systems. *Computers and Chemical Engineering*, 46, 39-47.
- Kondaveeti, S. R., Izadi, I., Shah, S. L., Shook, D. S., Kadali, R., & Chen, T. (2013). Quantification of alarm chatter based on run length distributions. *Chemical Engineering Research and Design*, 91, 2550-2558.
- Lai, S., & Chen, T. (2015). A method for pattern mining in multiple alarm flood sequences. *Chemical Engineering Research and Design*, in press.
- McDougall, A.J., D.S. Stoffer & D.E. Tyler (1997). Optimal transformations and the spectral envelope for real-valued time series. *Journal of Statistical Planning and Inference* 57, 195-214.



- Miao, T., & Seborg, D. E. (1999). Automatic detection of excessively oscillatory feedback control loops. In *Proc. of IEEE international Conference on Control Applications*, 359-364.
- Müller, M. (2007). Dynamic time warping, in *Information Retrieval for Music and Motion*. New York: Springer-Verlag, ch. 4, 69-82.
- Naghoosi, E., Izadi, I., & Chen, T. (2011). Estimation of alarm chattering. *Journal of Process Control*, 21, 1243-1249.
- Nair, G. N. (2013). A nonstochastic information theory for communication and state estimation. *IEEE Trans. Automatic Control*, 58(6), 1497-1510.
- Nimmo, I. (2005). Rescue your plant from alarm overload. *Chemical Processing*, 28-33.
- Noda, M., Higuchi, F., Takai, T., & Nishitani, H. (2011). Event correlation analysis for alarm system rationalization. *Asia-Pacific Journal of Chemical Engineering*, 6(3), 497-502.
- Qin, S.J. (1998). Control performance monitoring - a review and assessment. *Computer and Chemical Engineering*, 23, 173-186.
- Schleburg, M., Christiansen, L., Thornhill, N. F., & Fay, A. (2013). A combined analysis of plant connectivity and alarm logs to reduce the number of alerts in an automation system. *J. Process Control*, 23(6), 839-851.
- Schreiber, T. (2000). Measuring information transfer. *Physical Review Letters*, 85(2), 461.
- Smith, T. F., & Waterman, M. S. (1981). Identification of common molecular subsequences. *Journal of Molecular Biology*, 147, 195-197.
- Stoffer, David S. (1999). Detecting common signals in multiple time series using the spectral envelope. *Journal of the American Statistical Association*, 94, 1341-1356.
- Stoffer, David S., David E. Tyler & Andrew J. McDougall (1993). Spectral analysis for categorical time series: Scaling and spectral envelope. *Biometrika*, 80, 611-622.
- Stoffer, David S., Tyler, David E. & Wendt, David A. (2000). The spectral envelope and its applications. *Statistical Science*, 15, 224-253.
- Tangirala, A. K., Kanodia, J., & Shah, S. L. (2007). Non-negative matrix factorization for detection and diagnosis of plantwide oscillations. *Industrial & engineering chemistry research*, 46(3), 801-817.
- Tangirala, A. K., Shah, S. L., & Thornhill, N. F. (2005). PSCMAP: A new tool for plant-wide oscillation detection. *Journal of Process Control*, 15(8), 931-941.
- Thambirajah, J., Benabbas, L., Bauer, M., & Thornhill, N. F. (2009). Cause-and-effect analysis in chemical processes utilizing XML, plant connectivity and quantitative process history. *Computers & Chemical Engineering*, 33(2), 503-512.
- Thornhill, N. F., Huang, B., & Zhang, H. (2003a). Detection of multiple oscillations in control loops. *Journal of Process Control*, 13(1), 91-100.
- Thornhill, N. F., Cox, J. W., & Paulonis, M. A. (2003b). Diagnosis of plant-wide oscillation through data-driven analysis and process understanding. *Control Engineering Practice*, 11(12), 1481-1490.
- Thornhill, N. F., & Hägglund, T. (1997). Detection and diagnosis of oscillation in control loops. *Control Engineering Practice*, 5(10), 1343-1354.
- Thornhill, N.F., Shah, S.L., Huang, B., & Vishnubhotla, A. (2002). Spectral principal component analysis of dynamic process data. *Control Engineering Practice*, 10, 833-846.
- Timms, C. (2009). Hazards equal trips or alarms or both. *Process Safety and Environmental Protection*, 87, 3-13.
- Wang, J., & Chen, T. (2013). An online method for detection and reduction of chattering alarms due to oscillation. *Computers and Chemical Engineering*, 54, 140-150.
- Wang, J., & Chen, T. (2014). An online method to remove chattering and repeating alarms based on alarm durations and intervals. *Computers and Chemical Engineering*, 67, 43-52.
- Wang, J., Yang, F., Chen, T., & Shah, S.L. (2016). An Overview of Industrial Alarm Systems: Main Causes for Alarm Overloading, Research Status, and Open Problems. *IEEE Transactions on Automation Science and Engineering*, 13(2), 1045-1061.
- Welch, L. (1974). Lower bounds on the maximum cross correlation of signals (Corresp.). *IEEE Transactions on Information theory*, 20(3), 397-399.
- Xu, J., Wang, J., Izadi, I., & Chen, T. (2012). Performance assessment and design for univariate alarm systems based on FAR, MAR, and AAD. *IEEE Transactions on Automation Science and Engineering*, 9, 296-307.
- Yang, F., Duan, P., Shah, S. L., & Chen, T. (2014). *Capturing Connectivity and Causality in Complex Industrial Processes*. Springer Science & Business Media.
- Yang, F., Xiao, D., & Shah, S. L. (2010). Qualitative fault detection and hazard analysis based on signed directed graphs for large-scale complex systems. *Fault Detection*. INTECH Open Access Publisher.
- Yang, F., Shah, S.L., Xiao, D., & Chen, T. (2012). Improved correlation analysis and visualization of industrial alarm data. *ISA Transactions*, 51, 499-506.
- Yang, Z., Wang, J., & Chen, T. (2013). Detection of correlated alarms based on similarity coefficients of binary data. *IEEE Transactions on Automation Science and Engineering*, 10, 1014-1025.