

## ***AquoMin*: Targeting and Design of Mass-Exchange Networks featuring Regeneration Recycle**

Susana Relvas, Henrique A. Matos\*, Maria C. Fernandes and Clemente P. Nunes

Instituto Superior Técnico – DEQ - CPQ  
Av. Rovisco Pais 1049–001 Lisboa, Portugal

### **Abstract**

This study addresses the design of Mass Exchange Networks (MEN) featuring regeneration recycle. *AquoMin* is a friendly-user software based on Pinch Analysis and Mathematical Programming. It has been improved to include a new module dealing with the regeneration recycle strategy. A general algorithm was built to obtain the targets of this strategy.

An Example Problem is used to evaluate the results of the different strategies that can be employed to minimise water and wastewater flowrates. A trade-off between regeneration flowrate and concentration was achieved for the present strategy, leading to a regeneration flowrate reduction of 16% and an increase of 17% in inlet concentration of the regeneration process.

**Keywords:** MEN, regeneration recycle, mass pinch, wastewater minimisation, algorithm

### **1. Introduction**

In the last years the pinch concept has been applied to several areas of development. One of these areas is the water and wastewater minimisation in industry. The need to increase the knowledge of systematic methods to achieve the best operational strategy has been driven by the rising costs of fresh water and effluent treatment and stricter environmental legislation. The most common approaches to reduce fresh water consumption and wastewater production are:

- Reutilisation: wastewater with a certain level of contaminant is sent to a different process operation to perform a new mass transfer operation;
- Regeneration re-use: an intermediate regeneration process reduces the contaminant level in the wastewater before it is redirected to other process operations;
- Regeneration recycle: the regenerated water is used in operations where it was used before the regeneration process.

Wang and Smith (1994) first introduced the water pinch based methodology to obtain the targets for wastewater reutilisation, regeneration re-use and regeneration recycle. These strategies were improved by Kuo and Smith (1998). They classified operations through identified groups and then used a migration concept to minimise the targets.

---

\* Author to whom correspondence should be addressed: henrimatos@ist.utl.pt

Nowadays, mathematical programming is becoming widely used in pollution prevention, as Bagajewicz (2000) indicated in his work. Nevertheless graphical or source-sink tools are still being used, as stated by Dunn and El-Halwagi (2003). Relvas *et al.* (2004) established a methodology combining mass pinch and mathematical programming in the regeneration re-use design stage of *AquoMin* software. The present work develops a new regeneration recycle module for this tool.

## 2. Software Description

*AquoMin* software was developed in Microsoft's Visual Basic® to study the mass exchange alternatives of a given process. The dashed area in figure 1 represents work in progress concerning the regeneration recycle module. The user can also choose other three reutilisation alternatives: without or with reutilisation and regeneration re-use.

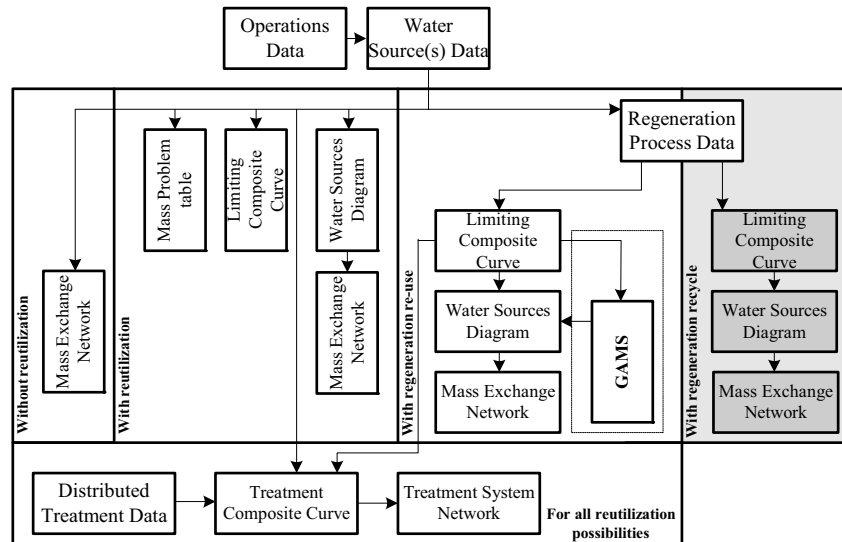

Figure 1. *AquoMin* program map, showing menus interdependence and current development area (□ Previous version, ■ New module) (adapted from Relvas *et al.* (2004))

## 3. The regeneration recycle module

Wang and Smith (1994) and Mann and Liu (1999) present two different approaches based on mass pinch for regeneration recycle targeting. A motivation example is used to show a different approach to this wastewater minimization strategy.

Table 1. Limiting data (Example Problem, Relvas *et al.* (2004)).

Operation	$F_{lim}$ (t/h)	$C_{in,max}$ (ppm)	$C_{out,max}$ (ppm)
1	48	15	200
2	35	50	300
3	12	125	350
4	70	250	450

Consider a process (Relvas *et al.* (2004)) with four operations using water to reduce the content of a contaminant. The limiting data is shown in table 1.  $F_{lim}$  is the limiting flowrate of the operation,  $C_{in,max}$  and  $C_{out,max}$  are the maximum inlet and outlet concentrations of the operation, respectively. The outlet concentration of the regeneration process ( $C_0$ ) is 40 ppm and the available external water source concentration ( $C_{EWS}$ ) is 0 ppm.

### 3.1 Minimum Fresh Water Flowrate ( $F_{min}$ )

Wang and Smith (1994) and Mann and Liu (1999) point out that minimum external flowrate ( $F_{min}$ ) can be reduced to the value dictated by the slope of the limiting composite curve below  $C_0$ . In some cases it may not be as simple as this rule. Figure 2 presents the Limiting Composite Curve (LCC) of the Example Problem. The first point of the LCC is not coincident with the beginning of the water profile line, since the external water source is fed at 0 ppm and the minimum  $C_{in,max}$  is 15 ppm. This means that  $F_{min}$  is obtained through the slope of the line given by the intercept between  $(0, C_{EWS})$  and  $(\Delta M_{cum,(C_0)}, C_0)$ . For the Example Problem,  $F_{min}$  is 30 t/h.

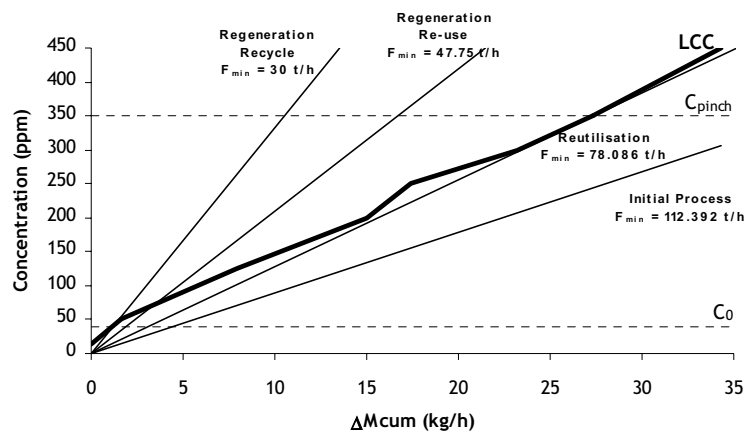

Figure 2. Minimum External Water Source Flowrate for different Wastewater Minimisation Strategies (Example Problem)

### 3.2 Regeneration and Recycle Flowrates

When recycle is allowed,  $F_{min}$  reaches a value below the other wastewater minimisation alternatives (figure 2) and a wide range of regenerated water flowrates ( $F_{reg}$ ) can be supplied to the region above  $C_0$ . In regeneration re-use,  $F_{min}$  and minimum concentration reduction (in the regeneration process) compatible with  $F_{min}$  were verified if the regeneration process was initialized at the pinch concentration ( $C_{pinch}$ ). Thus, there will be a set of flowrates where the total flowrate is  $F_{reg}$  and the mixing of these flowrates gives the final concentration of  $C_{pinch}$ .

Mann and Liu (1999) proposed the same procedure: to target regenerated water flowrate for a regeneration process between  $C_{pinch}$  and  $C_0$ . The consequence of this approach is the existence of  $F_{min}$  in the region above the pinch ( $F_{reg}$  was sent to regeneration), which enables to target  $F_{reg}$ . The LCC and overall water profile is presented in figure 3a.

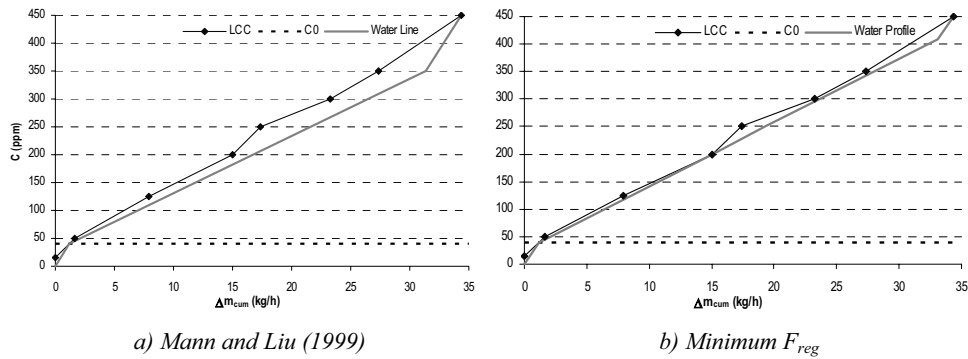

Figure 3. Regeneration Recycle Targeting Approaches (Example Problem)

It can be explored what happens if the regeneration process is allowed to start with a different inlet concentration (regarding the maximum removal ratio of the regeneration process previously assumed). If the slope between  $[C_0, C_{reg}]$  is increased ( $C_{reg}$  is the inlet concentration of the regeneration process)  $F_{reg}$  will decrease and  $C_{reg}$  becomes higher than  $C_{pinch}$ . Figure 3b represents the LCC of the example problem featuring regeneration recycle. The water profile reaches the LCC at 200 ppm,  $C_{reg}$  is 409.1 ppm and  $F_{reg}$  is 56.438 t/h.

The targeted flowrates can be confirmed constructing the Water Sources Diagram (WSD) for the Example Problem featuring Regeneration Recycle (figure 4). This approach handles targeting and design techniques. Castro *et al.* (1999) indicate the rules to build up a WSD. In figure 4 any extra regenerated flowrate used will be only circulating in the process in order to guarantee a different  $C_{reg}$  (for instance, 350 ppm, as Mann and Liu targeted).

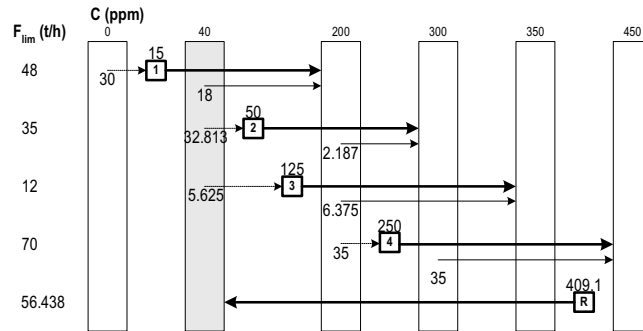

Figure 4. WSD featuring Regeneration Recycle with minimum  $F_{reg}$  (Example Problem)

### 3.4 Regeneration Recycle Targeting Algorithm

Figure 5 represents the targeting algorithm for regeneration recycle strategy, which is divided in two stages. The first stage uses as inputs the values of  $C_0$  and  $C_{EWS}$  and Mass Interval Co-ordinates for each  $j$  interval, which are provided by the construction of the Mass Problem Table (Castro *et al.* (1999)). There is a single step to obtain the output of this stage, which is  $F_{min}$  (section 3.2).  $\Delta m_{cum,C}$  represents the cumulated exchanged mass until concentration  $C$  is reached.

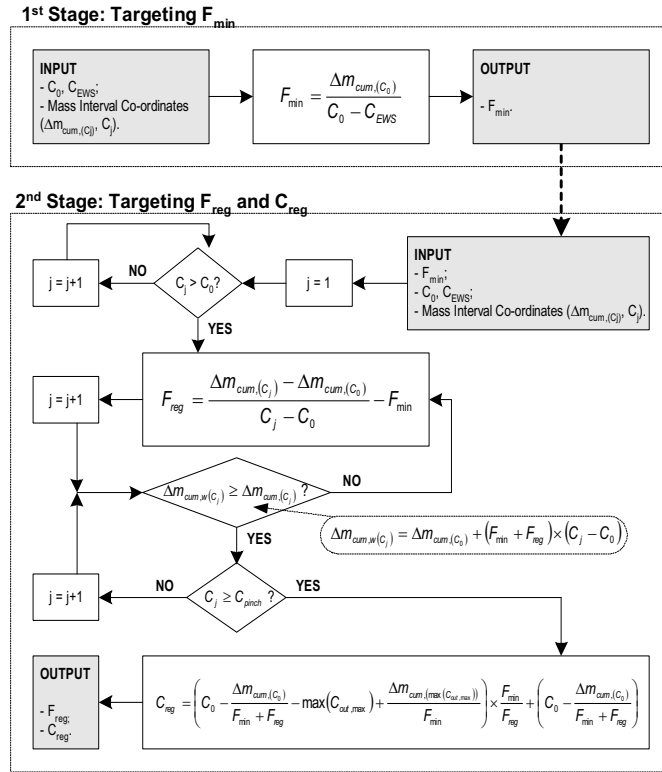

Figure 5. Regeneration Recycle Algorithm

This first target is used as input of the second stage. The remainder inputs are the same as in the first stage. The slope of the water profile line between  $C_0$  and the intercept that this line has with the last segment of the water profile is adjusted. The algorithm prevents the water profile line to cross the LCC. Once  $F_{reg}$  is minimised,  $C_{reg}$  is automatically obtained (section 3.3).

#### 4. Results

The Mass Exchange Network (MEN) featuring regeneration recycle with the targets obtained through the previous algorithm is displayed in figure 6. The different MEN results from the several wastewater minimisation alternatives are resumed and compared in table 2. The first two columns display the flowrate targets. The third column indicates the external water flowrate reduction compared with the initial problem. The fourth and fifth columns indicate the regeneration inlet concentration (if applicable) and wastewater concentration,  $C_{outs}$  (considering mixing of all effluents). The last column indicates the total number of interconnections between operations, regeneration process, external water source and wastewater.

Regeneration recycle achieves more than 70% of reduction external water consumption. The algorithm presented in section 3.4 reduces 16% the regeneration flowrate (compared with the targeting approach of Mann and Liu (1999)) and the regeneration

process should be able to accomplish a removal ratio (%RR) of 90.2%. Regeneration re-use MEN is the one with more interconnections, but with lower regenerated flowrate.

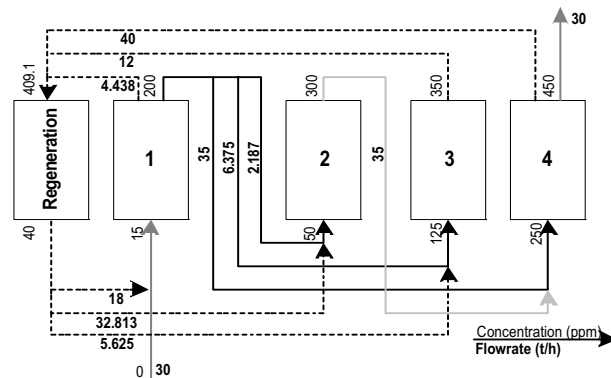

Figure 6. Mass Exchange Network featuring Regeneration Recycle (Example Problem)

Table 2. Targets obtained for the Example Problem under different alternatives of water and wastewater minimisation

Alternative	$F_{min}$ (t/h)	$F_{reg}$ (t/h)	Reduction <sup>a</sup> (%)	$C_{reg}$ (ppm)	$C_{out}$ (ppm)	Number of Interconnections
Initial Process	112.392	-	-	-	305.4	8
Reutilisation	78.086	-	30.5	-	439.6	11
Regeneration Re-use	47.75	41.427	57.5	350.0	450.0	18
Regeneration Recycle (Mann and Liu (1999))	30.0	67.192	73.3	350.0	450.0	13
Regeneration Recycle	30.0	56.438	73.3	409.1	450.0	12

<sup>a</sup> Calculated between the actual value of  $F_{min}$  and  $F_{min}$  of the initial problem.

## 5. Conclusions and Further Work

In this work the analysis of a wastewater minimisation problem is emphasized and the structural synthesis is encouraged on regeneration recycle problems. The current approach can be employed to target minimum regeneration flowrate, leaving as a degree of freedom the inlet concentration of the regeneration process. The design of the MEN featuring regeneration recycle is done after the targeting stage structured in an algorithm. The different strategies results are compared.

Further work can be done in *AquoMin* to include analysis of processes with more than one contaminant and a cost-based module to compare alternatives.

## References

- Castro, P., H.A. Matos, M.C. Fernandes and C.P. Nunes, 1999a, Chem. Eng. Sci., 54, 1649;
- Bagajewicz, M., 2000, Comp. Chem. Eng., 24, 2093;
- Dunn, R.F. and M.M. El-Halwagi, 2003, J. of Chemical Technology and Biotechnology, 78, issue 9, 1011;
- Kuo, W.-C.J. and R. Smith, 1998, Trans IChemE, 76, part B, 94;
- Mann, J.G., Y.A. Liu, 1999, *Industrial Water Reuse and Wastewater Minimization*, McGraw-Hill;
- Relvas, S., H.A. Matos, M.C. Fernandes, P. Castro and C.P. Nunes, 2004, ESCAPE14 Proceedings, 475;
- Wang, Y.P., R. Smith, 1994, Chem. Eng. Sci., 49, no. 7, 981.