

A NONLINEAR OUTPUT FEEDBACK CONTROL METHOD FOR MAGNETIC BEARING SYSTEMS*

Kang-Zhi Liu Rong He

Department of Electrical & Mechanical Engineering, Chiba University
1-33 Yayoi-cho, Inage-ku, Chiba 263-8255, Japan
Email: liu@cute.te.chiba-u.ac.jp

Keywords: Nonlinear Output Feedback Control, Magnetic Bearing systems, Virtual Input, Magnetic Force

Abstract

In this paper, a nonlinear output feedback control method is proposed for a magnetic bearing system which has a strong nonlinearity in the magnetic actuator. The basic idea is to make full use of the feature that the dynamics part is linear and hence can be stabilized by output feedback when the output of the actuator is regarded as a virtual input. Then it is shown that the backstepping and completing square techniques enable the construction of the real input using measured output only.

1 Introduction

In magnetic bearing systems the magnetic force has a strong nonlinearity, which is proportional to the square of electric current and inversely proportional to the square of distance between the magnetic bearing and the rotor. For this reason, in conventional magnetic control systems using linear control approaches *large* current biases have to be applied to a pair of electromagnets in order to guarantee that the magnetic force acting on the rotor can be approximated as a linear function of the currents. This large current bias does not contribute to control of magnetic bearing, thus is a waste of power. More importantly, the control system designed based on linear approximation works only in a very narrow range. To overcome this problem, a so-called "zero-power" control method is proposed in references[1, 2] which uses nonlinear state feedback so as to achieve zero-bias current. Further, [8] makes some improvements to the zero-power method. However, the designed nonlinear state feedback control law has a singularity at the equilibrium and for this reason asymptotic stability is not achieved. Meanwhile, in [10] a zero-bias nonlinear control method is proposed which guarantees asymptotic stability. [9] discussed a control method with exponentially decaying bias and [7] discussed low bias control. All these works are based on state feedback. How-

ever, when the rotor is flexible there is no way to measure all states and output feedback control becomes imperative. As the first step towards this goal, output feedback stabilization of a rigid rotor is treated in this paper. Extension to flexible rotor control will be published in forthcoming papers.

For this purpose, attention is focused on the dynamics property of this system, i.e. the magnetic bearing system is composed of a rotor and an actuator of electromagnets. The rotor is controlled by the magnetic force and the dynamics from this magnetic force to the states of rotor is linear. Therefore if this magnetic force is regarded as a virtual control input, linear feedback can be applied easily. Specifically, output feedback can be applied by using any known linear control theory. Meanwhile, the magnetic force is produced by a pair of electromagnets and is highly nonlinear, it is an open problem how to design an output feedback controller by backstepping. In this paper, it is first shown that the singularity in the control laws of [8, 1, 2] is due to the fact that the relative degree of the magnetic actuator is undefined if the bias current is zero and thus nonzero bias has to be applied in order for the backstepping technique[5] to be applicable. Then it is shown how one can design an output feedback controller by selecting suitable quadratic Lyapunov function and using the completing square technique. Also the condition on the structure of the linear part of the controller is analyzed and clarified.

Control of one-degree-of-freedom (1DOF) magnetic bearing system will be exposed in detail. Then the result on a 4DOF magnetic bearing system will be presented briefly.

2 Model of Magnetic Bearing System

Let us consider the 1DOF magnetic bearing system shown in Fig.1 first. In this figure, x denote the displacement of the rotor axis from the center, X_0 the gap between bearing and rotor at the equilibrium state, i_1, i_2 are the currents flowing through electromagnets 1 and 2 respectively. The voltage inputs applied to each electromagnet circuit are \bar{u}_1 and \bar{u}_2 . Only the displacement x and currents i_1, i_2

*Supported by JSPS Grant-14350224.

are measured.

To express the dynamics in state space form, the state variables are chosen as

$$\bar{x}_1 = x, \bar{x}_2 = \dot{x}, \bar{\xi}_1 = i_1, \bar{\xi}_2 = i_2. \quad (1)$$

Then, the state space model is described by

$$\dot{\bar{x}}_1 = \bar{x}_2 \quad (2)$$

$$\dot{\bar{x}}_2 = \frac{1}{M}f \quad (3)$$

$$y = \bar{x}_1 \quad (4)$$

$$\dot{\bar{\xi}}_1 = \frac{1}{L_1} \left[-R\bar{\xi}_1 - \frac{\partial L_1}{\partial \bar{x}_1} \bar{\xi}_1 \bar{x}_2 + \bar{u}_1 \right] \quad (5)$$

$$\dot{\bar{\xi}}_2 = \frac{1}{L_2} \left[-R\bar{\xi}_2 - \frac{\partial L_2}{\partial \bar{x}_1} \bar{\xi}_2 \bar{x}_2 + \bar{u}_2 \right] \quad (6)$$

in which the electromagnetic force f and the inductances L_1, L_2 are given by

$$f = k \left\{ \frac{\bar{\xi}_1^2}{(X_0 - \bar{x}_1)^2} - \frac{\bar{\xi}_2^2}{(X_0 + \bar{x}_1)^2} \right\}. \quad (7)$$

$$L_1 = \frac{2k}{X_0 - \bar{x}_1}, \quad L_2 = \frac{2k}{X_0 + \bar{x}_1} \quad (8)$$

In the above equations, M is the mass of rotor, R the resistance of each circuit and k a constant. Eqs. (2), (3) describe the dynamics of rotor, Eqs. (5), (6) are the state equations of electric circuits of the two electromagnets. These model can be easily found in any standard textbooks on magnetic dynamics, such as [3, 6].

It is worth noting that $L_1, L_2 > 0$ holds in the working range. There also holds equations

$$\frac{\partial L_1}{\partial x_1} = \frac{1}{2k}L_1^2, \quad \frac{\partial L_2}{\partial x_1} = -\frac{1}{2k}L_2^2. \quad (9)$$

Moreover, since the electromagnetic force f is a function of ξ_i^2 ($i = 1, 2$), it is sufficient only to use positive currents in control.

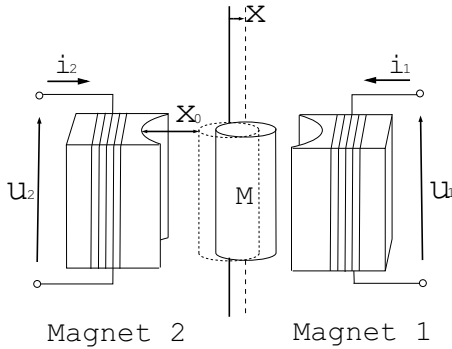

Figure 1: Model of 1DOF magnetic bearing system

2.1 Relative Degree of The Acuator

The equilibrium of the system is found to be

$$\bar{x}_1 = 0, \bar{x}_2 = 0, \bar{\xi}_1 = \bar{\xi}_2 = \epsilon, \bar{u}_1 = \bar{u}_2 = R\epsilon$$

in which ϵ is arbitrary. Note the equilibrium is not an isolated point, it is a set which corresponds to the fact that this system can have any electricity bias at the equilibrium. Now let us look at the effect of bias on stabilization technique. In backstepping, the relative degree of the actuator must be well defined. Since the output of the actuator is f and the coefficient of the input \bar{u}_i is $1/L_i$ ($i = 1, 2$), there holds

$$\frac{\partial f}{\partial \bar{\xi}_i} \frac{1}{L_i} = \frac{1}{2k}L_i \bar{\xi}_i.$$

So if the current at equilibrium is $\epsilon = 0$, the relative degree is not 1 at the equilibrium. Continuing the calculation on the relative degree, it is discovered that the relative degree is not defined at all. This means that in order for the backstepping technique to be applicable, some bias current has to be applied, i.e. $\epsilon > 0$. In this case, the actuator has a relative degree of 1 around the equilibrium. It is assumed that the bias is chosen as such in the sequel.

For convenience, the equilibrium is shifted to the origin as follows

$$\begin{aligned} x_1 &= \bar{x}_1, \quad x_2 = \bar{x}_2 \\ \xi_1 &= \bar{\xi}_1 - \epsilon, \quad \xi_2 = \bar{\xi}_2 - \epsilon \\ u_1 &= \bar{u}_1 - R\epsilon, \quad u_2 = \bar{u}_2 - R\epsilon. \end{aligned}$$

Then the state equations in the new coordinate become

$$\dot{x}_1 = x_2, \quad \dot{x}_2 = \frac{1}{M}f \quad (10)$$

$$y = x_1 \quad (11)$$

for the linear dynamics and

$$\dot{\xi}_1 = \frac{1}{L_1} \left[-R\xi_1 - \frac{\partial L_1}{\partial x_1} \bar{\xi}_1 x_2 + u_1 \right] \quad (12)$$

$$\dot{\xi}_2 = \frac{1}{L_2} \left[-R\xi_2 - \frac{\partial L_2}{\partial x_1} \bar{\xi}_2 x_2 + u_2 \right] \quad (13)$$

$$f = \frac{1}{4k} (L_1^2 \bar{\xi}_1^2 - L_2^2 \bar{\xi}_2^2) \quad (14)$$

for the actuator.

3 Control Design

As is clear from the state equation, if the magnetic force f is regarded as a virtual control input, then the dynamics of the rotor subsystem becomes linear. So linear control can be applied to stabilize this subsystem. After that, voltage input needs to be designed so as to realize the magnetic force designed in the 1st step. That is, the design process can be decomposed into 2 steps as follow.

1. Construct f^* by linear dynamic output feedback of y
2. Use backstepping and completing square technique to find \bar{u}_1, \bar{u}_2 using only the measured output ($y, \xi_1, \bar{\xi}_2$)

They are described in the following subsections respectively.

3.1 Structural Requirement on Linear Controller

First of all, the condition on the linear dynamic output feedback controller $K(s)$ is discussed such that the input of nonlinear actuator can be realized by dynamic output feedback.

Lemma 1 *The relative degree of $K(s)$ must be greater than or equal to that of the actuator in order for dynamic output feedback to be realizable.*

(Proof) Suppose the relative degree of the actuator is γ , then derivatives of f^* up to $f^{*(\gamma)}$ will be used in the backstepping design. Let a state space realization of $K(s)$ be

$$\dot{x}_k = A_k + b_k y, \quad f^* = c_k x_k + d_k y. \quad (15)$$

Then

$$\begin{aligned} f^{*(i)} &= c_k A_k^i x_k + c_k A_k^{i-1} b_k y + c_k A_k^{i-2} b_k \dot{y} \\ &+ \dots + c_k b_k y^{(i-1)} + d_k y^{(i)}. \end{aligned}$$

So the derivatives of f^* up to $f^{*(\gamma)}$ are independent of derivatives of y iff

$$d_k = c_k b_k = c_k A_k b_k = \dots = c_k A_k^{\gamma-2} b_k = 0$$

holds. That is the relative degree of $K(s)$ must not be lower than γ . \diamond

3.2 Output Feedback Design of Magnetic Force

Let us assume that the magnetic force f can be manipulated directly and consider the control of rotor by this virtual input first. Let $x = [x_1, x_2]^T$ denote the state vector, then the state equation of the rotor can be written as

$$\dot{x} = Ax + bf, \quad y = cx \quad (16)$$

in which

$$A = \begin{bmatrix} 0 & 1 \\ 0 & 0 \end{bmatrix}, \quad b = \begin{bmatrix} 0 \\ 1/M \end{bmatrix}, \quad c = [1 \ 0].$$

Obviously, this system is controllable and observable, thus can be stabilized by linear dynamic output feedback. The relative degree of $K(s)$ must not be lower than 1 because the relative degree of the electromagnetic actuator is 1.

Assume that this linear stabilizing controller $K(s)$ is given by

$$\dot{x}_k = A_k + b_k y, \quad f^* = c_k x_k. \quad (17)$$

To find a state space realization for this linear closed subsystem, let us define some notations as follows

$$f_e = f - f^*, \quad \zeta = [x^T, x_k^T]^T. \quad (18)$$

Then it is easy to verify that the state equation of the closed loop subsystem is

$$\dot{\zeta} = A_c \zeta + b_c f_e \quad (19)$$

in which

$$A_c = \begin{bmatrix} A & b c_k \\ b_k c & A_k \end{bmatrix}, \quad b_c = \begin{bmatrix} b \\ 0 \end{bmatrix}.$$

Before proceeding to the next step of control design, we need to construct a Lyapunov function for this linear closed subsystem and compute the desired currents. Both will be used in the backstepping design.

Since A_c is stable, there exists a matrix $P > 0$ satisfying the Lyapunov equation below

$$A_c^T P + P A_c + I = 0. \quad (20)$$

Now set a quadratic function as

$$V_1(\zeta) = \zeta^T P \zeta. \quad (21)$$

Its derivative is given by

$$\begin{aligned} \dot{V}_1 &= \dot{\zeta}^T P \zeta + \zeta^T P \dot{\zeta} \\ &= \zeta^T (A_c^T P + P A_c) \zeta + \zeta^T (P b_c f_e) + (P b_c f_e)^T \zeta \\ &= -\|\zeta\|^2 + \zeta^T (P b_c f_e) + (P b_c f_e)^T \zeta. \end{aligned} \quad (22)$$

When $f = f^*$, \dot{V}_1 is a negative function. So V_1 is a Lyapunov function for this subsystem.

Next, let us find the electric currents (ξ_1^*, ξ_2^*) corresponding to f^* . It is clear from Eq. (7) that the currents ξ_1, ξ_2 can not be determined uniquely. So let us find ξ_1^*, ξ_2^* that minimize the index

$$J = \min\{\xi_1^2 + \xi_2^2\}$$

subject to the constraint

$$f^* = \frac{1}{4k} [L_1^2 (\xi_1^* + \epsilon)^2 - L_2^2 (\xi_2^* + \epsilon)^2].$$

This can be interpreted as the minimization of the deviation of current power from the bias. It is easy to see that the optimal solution must satisfy

$$\begin{aligned} \xi_1 &= 0, \quad f^* = \frac{1}{4k} [L_1^2 \epsilon^2 - L_2^2 (\xi_2 + \epsilon)^2] & (f^* < 0) \\ \xi_1 &= \xi_2 = 0 & (f^* = 0) \\ \xi_2 &= 0, \quad f^* = \frac{1}{4k} [L_1^2 (\xi_2 + \epsilon)^2 - L_2^2 \epsilon^2] & (f^* > 0). \end{aligned}$$

From these equations, the required currents ξ_1^*, ξ_2^* are obtained as:

$$\xi_1^* = \begin{cases} -\epsilon + \frac{1}{L_1} \sqrt{4k f^* + L_2^2 \epsilon^2}, & f^* > 0 \\ 0, & f^* \leq 0 \end{cases} \quad (23)$$

$$\xi_2^* = \begin{cases} 0, & f^* \geq 0 \\ -\epsilon + \frac{1}{L_2} \sqrt{-4k f^* + L_1^2 \epsilon^2}, & f^* < 0 \end{cases} \quad (24)$$

This control law is a switching control law and is physically extremely natural. f^* acts as the switching surface. It is also noted that

$$\bar{\xi}_1^* = \xi_1^* + \epsilon \geq \epsilon > 0, \quad \bar{\xi}_2^* = \xi_2^* + \epsilon \geq \epsilon > 0. \quad (25)$$

3.3 Design of Voltage Inputs

As in standard backstepping, the error between real currents ξ_1, ξ_2 and required currents ξ_1^*, ξ_2^* are defined as

$$e_1 = \xi_1 - \xi_1^*, \quad e_2 = \xi_2 - \xi_2^*.$$

Their dynamics are given by

$$\begin{aligned} \dot{e}_1 &= \dot{\xi}_1 - \dot{\xi}_1^* \\ &= \frac{1}{L_1} \left[-R\xi_1 - \frac{\partial L_1}{\partial x_1} \bar{\xi}_1 x_2 + u_1 - L_1 \dot{\xi}_1^* \right] \end{aligned} \quad (26)$$

$$\begin{aligned} \dot{e}_2 &= \dot{\xi}_2 - \dot{\xi}_2^* \\ &= \frac{1}{L_2} \left[-R\xi_2 - \frac{\partial L_2}{\partial x_1} \bar{\xi}_2 x_2 + u_2 - L_2 \dot{\xi}_2^* \right] \end{aligned} \quad (27)$$

It is noted that f_e can be expressed as

$$f_e = \frac{1}{4k} \left[L_1^2 (\bar{\xi}_1 + \bar{\xi}_1^*) e_1 - L_2^2 (\bar{\xi}_2 + \bar{\xi}_2^*) e_2 \right] \quad (28)$$

in terms of e_1, e_2 . There also holds

$$\begin{aligned} &\frac{\partial L_1}{\partial x_1} \left(\frac{1}{2} e_1 - \bar{\xi}_1 \right) e_1 + \frac{\partial L_2}{\partial x_1} \left(\frac{1}{2} e_2 - \bar{\xi}_2 \right) e_2 \\ &= -\frac{1}{4k} \left[L_1^2 (\bar{\xi}_1 + \bar{\xi}_1^*) e_1 - L_2^2 (\bar{\xi}_2 + \bar{\xi}_2^*) e_2 \right] \\ &= -f_e. \end{aligned}$$

The key point in obtaining a simple output control law is to use the following quadratic function

$$V(\zeta, e_1, e_2) = V_1 + \frac{1}{2} L_1 e_1^2 + \frac{1}{2} L_2 e_2^2 \quad (29)$$

as a candidate of control Lyapunov function for the whole system.

Theorem 1 Define the following parameters

$$\bar{P} = P - \frac{M}{2} I, \quad \lambda = \|\bar{P} b_c\|^2, \quad \kappa = b_c^T \bar{P} b_c$$

and signals

$$\begin{aligned} w_1 &= \begin{cases} 0, & f^* \leq 0 \\ -\frac{M}{2k} \left(L_1^2 \bar{\xi}_1^* + \epsilon^2 \frac{L_2^3}{L_1 \xi_1^*} \right), & f^* > 0 \end{cases} \\ v_1 &= \begin{cases} 0, & f^* \leq 0 \\ 2k \frac{f^*}{L_1 \xi_1^*}, & f^* > 0 \end{cases} \\ w_2 &= \begin{cases} \frac{M}{2k} \left(L_2^2 \bar{\xi}_2^* + \epsilon^2 \frac{L_1^3}{L_2 \xi_2^*} \right), & f^* < 0 \\ 0, & f^* \geq 0 \end{cases} \\ v_2 &= \begin{cases} -2k \frac{f^*}{L_2 \xi_2^*}, & f^* < 0 \\ 0, & f^* \geq 0 \end{cases} \\ w &= w_1 e_1 + w_2 e_2. \end{aligned}$$

Then the following dynamic output feedback control input

$$\begin{aligned} \dot{x}_k &= A_k + b_k y, \quad f^* = c_k x_k \\ u_1 &= R\xi_1^* - \frac{\lambda}{4k} L_1^2 (\bar{\xi}_1 + \bar{\xi}_1^*) f_e + v_1 + \kappa w_1 f_e \\ &\quad - \frac{1}{4M^2} w_1^2 e_1 - c_1 e_1, \quad c_1 > 0 \\ u_2 &= R\xi_2^* + \frac{\lambda}{4k} L_2^2 (\bar{\xi}_2 + \bar{\xi}_2^*) f_e + v_2 + \kappa w_2 f_e \\ &\quad - \frac{1}{4M^2} w_2^2 e_2 - c_2 e_2, \quad c_2 > 0 \end{aligned} \quad (30)$$

achieves global asymptotic stability of the magnetic bearing system.

(Proof) Differentiation of the quadratic function V of (29) along the trajectory yields

$$\begin{aligned} \dot{V} &= -\|\zeta\|^2 + \zeta^T (P b_c f_e) + (P b_c f_e)^T \zeta \\ &\quad + L_1 \dot{e}_1 e_1 + \frac{1}{2} \frac{\partial L_1}{\partial x_1} e_1^2 x_2 + L_2 \dot{e}_2 e_2 + \frac{1}{2} \frac{\partial L_2}{\partial x_1} e_2^2 x_2 \\ &= -\|\zeta\|^2 + \zeta^T (P b_c f_e) + (P b_c f_e)^T \zeta \\ &\quad + \frac{\partial L_1}{\partial x_1} \left(\frac{1}{2} e_1 - \bar{\xi}_1 \right) e_1 x_2 + \frac{\partial L_2}{\partial x_1} \left(\frac{1}{2} e_2 - \bar{\xi}_2 \right) e_2 x_2 \\ &\quad + e_1 \left(u_1 - R\xi_1 - L_1 \dot{\xi}_1^* \right) + e_2 \left(u_2 - R\xi_2 - L_2 \dot{\xi}_2^* \right) \\ &= -\|\zeta\|^2 + \zeta^T (P b_c f_e) + (P b_c f_e)^T \zeta - x_2 f_e \\ &\quad + e_1 \left(u_1 - R\xi_1 - L_1 \dot{\xi}_1^* \right) + e_2 \left(u_2 - R\xi_2 - L_2 \dot{\xi}_2^* \right). \end{aligned}$$

Since $x_2 = M b_c^T \zeta$, completion of square yields

$$\begin{aligned} \dot{V} &= -\|\zeta\|^2 + \zeta^T \bar{P} b_c f_e + f_e b_c^T \bar{P}^T \zeta \\ &\quad + e_1 \left(u_1 - R\xi_1 - L_1 \dot{\xi}_1^* \right) + e_2 \left(u_2 - R\xi_2 - L_2 \dot{\xi}_2^* \right) \\ &= -\|\zeta - \bar{P} b_c f_e\|^2 + \|\bar{P} b_c f_e\|^2 \\ &\quad + e_1 \left(u_1 - R\xi_1 - L_1 \dot{\xi}_1^* \right) + e_2 \left(u_2 - R\xi_2 - L_2 \dot{\xi}_2^* \right). \end{aligned}$$

As $\|\bar{P} b_c f_e\|^2 = \lambda f_e^2$ is equal to

$$\frac{\lambda}{4k} f_e \left[L_1^2 (\bar{\xi}_1 + \bar{\xi}_1^*) e_1 - L_2^2 (\bar{\xi}_2 + \bar{\xi}_2^*) e_2 \right],$$

there holds

$$\begin{aligned} \dot{V} &= -\|\zeta - \bar{P} b_c f_e\|^2 - \left(e_1 L_1 \dot{\xi}_1^* + e_2 L_2 \dot{\xi}_2^* \right) \\ &\quad + e_1 \left[u_1 - R\xi_1 + \frac{\lambda}{4k} f_e L_1^2 (\bar{\xi}_1 + \bar{\xi}_1^*) \right] \\ &\quad + e_2 \left[u_2 - R\xi_2 - \frac{\lambda}{4k} f_e L_2^2 (\bar{\xi}_2 + \bar{\xi}_2^*) \right]. \end{aligned} \quad (31)$$

Further, straightforward but tedious computation based on (9) yields

$$L_1 \dot{\xi}_1^* = w_1 b_c^T \zeta + v_1, \quad L_2 \dot{\xi}_2^* = w_2 b_c^T \zeta + v_2.$$

Noting $w_1 w_2 = 0$, it is obtained that

$$\begin{aligned}
& e_1 L_1 \dot{\xi}_1^* + e_2 L_2 \dot{\xi}_2^* \\
&= w b_c^T (\zeta - \bar{P} b_c f_e) + \kappa w f_e + e_1 v_1 + e_2 v_2 \\
&= -\|\zeta - \bar{P} b_c f_e\|^2 + \|\zeta - \bar{P} b_c f_e + \frac{1}{2} b_c w\|^2 \\
&\quad - \|\frac{1}{2} b_c w\|^2 + e_1 [v_1 + \kappa w_1 f_e] + e_2 [v_2 + \kappa w_2 f_e] \\
&= -\|\zeta - \bar{P} b_c f_e\|^2 + \|\zeta - \bar{P} b_c f_e + \frac{1}{2} b_c w\|^2 \\
&\quad + e_1 [v_1 + \kappa w_1 f_e] + e_2 [v_2 + \kappa w_2 f_e] \\
&\quad - \frac{1}{4M^2} (w_1^2 e_1^2 + w_2^2 e_2^2).
\end{aligned}$$

So finally, substitution of the control input (30) into (31) yields

$$\begin{aligned}
\dot{V} &= -\|\zeta - \bar{P} b_c f_e + \frac{1}{2} b_c w\|^2 \\
&\quad - (c_1 + R) e_1^2 - (c_2 + R) e_2^2 \\
&\leq 0.
\end{aligned}$$

Moreover, $\dot{V} \equiv 0$ iff

$$\zeta - \bar{P} b_c f_e + \frac{1}{2} b_c w = 0, \quad e_1 = e_2 = 0.$$

As $e_1 = e_2 = 0$ implies $f_e = 0$ and $w = 0$, this condition is equivalent to

$$\zeta = 0, \quad e_1 = e_2 = 0.$$

Further,

$$\zeta = 0 \Rightarrow x_k = 0 \Rightarrow f^* = 0 \Rightarrow \xi_1^* = \xi_2^* = 0,$$

and

$$e_1 = e_2 = 0 \Rightarrow \xi_1 = \xi_1^* = 0, \quad \xi_2 = \xi_2^* = 0.$$

Therefore, the global asymptotic stability is guaranteed by LaSalle's invariance principle. \diamond

Note that w_i, v_i are finite since $\bar{\xi}_i^* > 0$. Therefore, the control input given in the theorem is also finite.

4 4DOF Magnetic Bearing System

Next, consider a multi-DOF magnetic bearing system shown in Fig.2 which has 8 electromagnets. It is assumed that the rotor rotates at a constant speed, that is $\omega_z = \text{const}$. Then the DOF of motion is 4.

The motion equations of this rotor for this system are given by

$$m \ddot{x}_G = f_x \quad (32)$$

$$m \ddot{y}_G = f_y \quad (33)$$

$$J_r \ddot{\theta}_y - J_a \omega_z \dot{\theta}_x = \tau_y \quad (34)$$

$$J_r \ddot{\theta}_x + J_a \omega_z \dot{\theta}_y = \tau_x \quad (35)$$

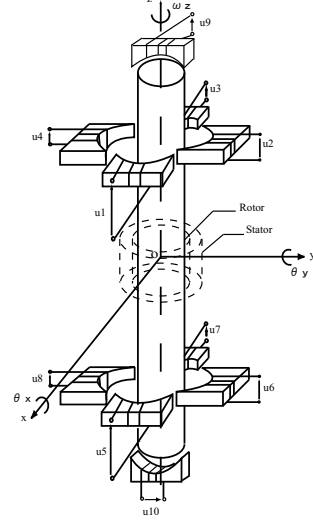

Figure 2: mDOF magnetic bearing system

in which m denotes mass of the rotor, J_r is the inertial moment around x and y axes and J_a the inertial moment around z axis. The gaps between the rotor and the 8 electromagnets are given by

$$\begin{aligned}
x_u &= l \sin \theta_y - x_G, \quad x_l = l \sin \theta_y + x_G \\
y_u &= l \sin \theta_x - y_G, \quad y_l = l \sin \theta_x + y_G.
\end{aligned}$$

Then the electric circuit dynamics are described by

$$\dot{\xi}_i = \begin{cases} \frac{1}{L_i} \left(-R \xi_i - \frac{\partial L_i}{\partial x_u} \bar{\xi}_i x_2 + u_i \right), & i = 1, 3 \\ \frac{1}{L_i} \left(-R \xi_i - \frac{\partial L_i}{\partial x_l} \bar{\xi}_i x_2 + u_i \right), & i = 5, 7 \\ \frac{1}{L_i} \left(-R \xi_i - \frac{\partial L_i}{\partial y_u} \bar{\xi}_i x_2 + u_i \right), & i = 2, 4 \\ \frac{1}{L_i} \left(-R \xi_i - \frac{\partial L_i}{\partial y_l} \bar{\xi}_i x_2 + u_i \right), & i = 6, 8 \end{cases}$$

in which $\xi_{i/j} = \bar{\xi}_{i/j} - \epsilon$, $u_{i/j} = \bar{u}_{i/j} - R\epsilon$. The forces and torques are given by

$$f_x = \frac{1}{4k} \left[L_1^2 \bar{\xi}_1^{-2} - L_3^2 \bar{\xi}_3^{-2} + L_5^2 \bar{\xi}_5^{-2} - L_7^2 \bar{\xi}_7^{-2} \right] \quad (36)$$

$$f_y = \frac{1}{4k} \left[L_2^2 \bar{\xi}_2^{-2} - L_4^2 \bar{\xi}_4^{-2} + L_6^2 \bar{\xi}_6^{-2} - L_8^2 \bar{\xi}_8^{-2} \right] \quad (37)$$

$$\tau_y = \frac{l}{4k} \left[L_1^2 \bar{\xi}_1^{-2} - L_3^2 \bar{\xi}_3^{-2} - L_5^2 \bar{\xi}_5^{-2} + L_7^2 \bar{\xi}_7^{-2} \right] \quad (38)$$

$$\tau_x = \frac{l}{4k} \left[-L_2^2 \bar{\xi}_2^{-2} + L_4^2 \bar{\xi}_4^{-2} + L_6^2 \bar{\xi}_6^{-2} - L_8^2 \bar{\xi}_8^{-2} \right] \quad (39)$$

Define $X = [x_G, \dot{x}_G]$, $Y = [y_G, \dot{y}_G]$, $\Psi = [\theta_y, \dot{\theta}_y, \theta_x, \dot{\theta}_x]$ and $T = [\tau_y, \tau_x]$, then the state equation becomes

$$\dot{X} = A_x X + b_x f_x \quad (40)$$

$$\dot{Y} = A_y Y + b_y f_y \quad (41)$$

$$\dot{\Psi} = A_\psi \Psi + B_\psi T. \quad (42)$$

The measured output in the rotor dynamics is

$$y = [x_G, y_G, \theta_y, \theta_x]$$

which is determined from the gaps x_u , x_l , y_u , y_l that are measured by laser sensors.

Since these three state equations are decoupled, decentralized output feedback f_x^* , f_y^* , T^* can be designed to stabilize X , Y , Ψ respectively. Further, from the designed f_x^* , f_y^* , T^* and the equations above, the desired currents ξ_i^* can be computed. As in the 1DOF case, ξ_1^* , \dots , ξ_8^* are determined in such a way that minimizes the total power. Each of them switches between a positive function and 0 according to the signs of the following switching functions

$$\begin{aligned} s_1 &= f_x^* + \tau_y^*/l, & s_2 &= f_y^* - \tau_x^*/l \\ s_3 &= f_x^* - \tau_y^*/l, & s_4 &= f_y^* + \tau_x^*/l. \end{aligned}$$

The desired currents are listed below.

$$\begin{aligned} \xi_1^* &= \begin{cases} \frac{1}{L_1} \sqrt{2ks_1 + L_3^2 \epsilon^2} - \epsilon, & s_1 > 0 \\ 0, & s_1 \leq 0 \end{cases} \\ \xi_2^* &= \begin{cases} \frac{1}{L_2} \sqrt{2ks_2 + L_4^2 \epsilon^2} - \epsilon, & s_2 > 0 \\ 0, & s_2 \leq 0 \end{cases} \\ \xi_3^* &= \begin{cases} 0, & s_1 \geq 0 \\ \frac{1}{L_3} \sqrt{-2ks_1 + L_1^2 \epsilon^2} - \epsilon, & s_1 < 0 \end{cases} \\ \xi_4^* &= \begin{cases} 0, & s_2 \geq 0 \\ \frac{1}{L_4} \sqrt{-2ks_2 + L_2^2 \epsilon^2} - \epsilon, & s_2 < 0 \end{cases} \\ \xi_5^* &= \begin{cases} \frac{1}{L_5} \sqrt{2ks_3 + L_7^2 \epsilon^2} - \epsilon, & s_3 > 0 \\ 0, & s_3 \leq 0 \end{cases} \\ \xi_6^* &= \begin{cases} \frac{1}{L_6} \sqrt{2ks_4 + L_8^2 \epsilon^2} - \epsilon, & s_4 > 0 \\ 0, & s_4 \leq 0 \end{cases} \\ \xi_7^* &= \begin{cases} 0, & s_3 \geq 0 \\ \frac{1}{L_7} \sqrt{-2ks_3 + L_5^2 \epsilon^2} - \epsilon, & s_3 < 0 \end{cases} \\ \xi_8^* &= \begin{cases} 0, & s_4 \geq 0 \\ \frac{1}{L_8} \sqrt{-2ks_4 + L_6^2 \epsilon^2} - \epsilon, & s_4 < 0 \end{cases} \end{aligned}$$

By using the following Lyapunov function

$$V = \zeta^T P \zeta + \frac{1}{2} \sum_{k=1}^8 L_k e_k^2 \quad (43)$$

an output feedback control law $u = [u_1, \dots, u_8]^T$ can be obtained which has a structure similar to the 1DOF case. This control voltage guarantees global asymptotic stability of the whole system. The detail is omitted due to space limitation.

5 Conclusion

In this paper, a nonlinear dynamic output feedback control method for magnetic bearing systems has been proposed. This method guarantees asymptotic stability of the closed loop system and uses only a slight bias current.

This approach can be extended to systems with uncertain linear dynamics and/or distributed linear dynamics. Also,

the extension to magnetic levitation systems is straightforward. These extensions will be reported in forthcoming papers.

Simulation results will be shown in the conference, if time permitting.

References

- [1] Y. Ariga and K. Nonami and T. Kamiyama: Nonlinear zero-power control of a electrical power storing fly-wheel (Derivation of nonlinear control ignoring the gyro-effect) (in Japanese), *Journal of Japan AEM Society*, **8-3**, pp. 403-410 (2000)
- [2] Y. Ariga and K. Nonami and K. Sakai: Nonlinear control of zero-power magnetic bearing systems (Part 2: experimental verification) (in Japanese), *Trans. of JSME(C)*, **65-638**, pp. 4012-4018 (2001)
- [3] Eds. JSME: *Basics and Applications of Magnetic Bearings* (in Japanese), Yokendo (1995)
- [4] H. K. Khalil: *Nonlinear Systems*, Prentice Hall (1996)
- [5] M. Krstić and I. Kanellakopoulos and P. Kokotović: *Nonlinear and Adaptive Control Design*, Wiley (1995)
- [6] Eds. IEEJ: *Magnetic suspension technology - Magnetic levitation systems and magnetic bearings-* (in Japanese), Corona Publishing Co, Ltd. (1993)
- [7] C. Knospe and C. Yang, "Gain-Scheduled Control of a Magnetic Bearing with Low Bias Flux," Proceedings of the 36th IEEE Conference on Decision and Control, pp. 418-423 (1997)
- [8] K.-Z. Liu and A. Ikai and A. Ogata and O. Saito: A nonlinear switching control method for magnetic bearing systems -minimizing the power consumption-, *Proc. of the 15th IFAC World Conference* (2002)
- [9] N. Motee, M.S. de Queiroz, Y. Fang, and D.M. Dawson, "Active magnetic Bearing Control with Zero Steady-State Power Loss," Proceedings of the American Control Conference, Anchorage, AK. (May 8-10, 2002)
- [10] P. Tsiotras and E. Velenis, "Control of a Zero-Bias Magnetic Bearing Using Control Lyapunov Functions," Proc. IEEE Conf. Decision and Control, pp. 4048-4053, Sydney, Australia (Dec. 2000)