

Experimental validation of wind turbine higher harmonic control using shaft loads measurements

Vlaho Petrović*, Filippo Campagnolo†

*University of Zagreb, Faculty of Electrical Engineering and Computing,
Email: vlaho.petrovic@fer.hr

†Dipartimento di Ingegneria Aerospaziale, Politecnico di Milano,
Email: campagnolo@aero.polimi.it

Abstract—In order to achieve reductions in wind turbine structural loads and to enable further increase of wind turbine rated power and dimensions, individual pitch control algorithms received significant portion of attention in the scientific community in the recent years. Individual pitch control typically reduces only the first loads harmonic, but as the wind turbines grow in size, it is expected that higher harmonics will have to be reduced as well. Instead of using blade loads, which is typical approach in the literature, this paper analyses the possibilities of reduction of higher harmonics from the wind turbine loads using the shaft measurements. To this aim, loads transformations capable of extracting information about higher loads harmonics from shaft measurements are derived. The controller for load reduction based on such transformations is implemented on a scaled wind turbine model and experimentally validated in the wind tunnel at Politecnico di Milano.

I. INTRODUCTION

The use of wind turbines has grown rapidly in recent decades and that trend is likely to continue. The main reason for this is constantly increasing power consumption, which necessitates introduction of new power plants. At the same time, the climate change concerns prompt for an immediate action in reducing the greenhouse gas emissions. Another important factor is concentration of natural reserves of fossil fuels in just a few supplier countries in the world. In order to take care of climate change and to reduce dependency on energy import, the European Union (EU) has set goal to achieve 20% share of renewable energies in the overall energy consumption by 2020 [1]. Since nowadays wind is the most promising renewable energy source, it is expected that wind energy will have a major role in achieving that goal. Furthermore, several studies suggest that the importance of wind energy will increase beyond the 2020 goal (see e.g. [2], [3]). Wind turbines have no greenhouse gas emissions and wind is free and practically limitless source of energy, so wind turbines represent a good solution for both climate change and energy import dependency.

Such ambitious goals for wind energy cannot be achieved with the current state of technology, so constant research and development are needed. To be able to pursue set goals, wind turbine dimensions and rated power will have to increase. However, with the increase in wind turbine dimensions, the loads that wind turbine has to withstand increase significantly. An attempt to make such large constructions (modern 5 MW wind turbines have tower height

over 100 m) rigid would result with massive and expensive structures, which in turn would make the whole wind turbine cost-ineffective [4]. Therefore advanced wind turbine control is needed that will reduce the loads without reducing the quality of the wind turbine power output. One of such control concepts is individual pitch control, which has received a significant portion of attention in the scientific community in recent years. The main goal of individual pitch control is to reduce the first harmonic of the blade loads by introducing the additional blade pitch action on the same frequency. Obviously such control algorithm increases the blade pitch activity, but since the first loads harmonic is typically very emphasized, it can also significantly reduce the fatigue and prolong the wind turbine expected lifetime. Note that such control action typically does not stress the pitch actuator too much as the frequency of the first harmonic for the modern multi-megawatt wind turbines is typically below 0.5 Hz – with notable trend of reducing nominal rotor speed (and hence the frequency of the first harmonic) as the wind turbines grow in size.

As the wind turbine dimensions and structural loads increase, it is expected that reduction of the higher loads harmonics might also have significant impact on wind turbine fatigue and expected lifetime. Therefore the reduction of the higher loads harmonics has also been researched in recent years, where most authors use control concept similar to basic individual pitch control based on measurements of blade structural loads, see e.g. [5], [6]. Although control algorithms for reduction of higher loads harmonics demand even higher pitch activity than basic individual pitch control, the pitch actuators are expected to be able to cope with that. Namely, as the wind turbine dimensions increase, nominal rotor speed and therefore the frequencies of the harmonics typically decrease, which lowers the demands on the pitch rates.

Before the wind turbine designers can fully rely on the reduction of higher loads harmonics while designing the wind turbines, first such control concepts have to be thoroughly validated both in simulations and experimentally. This paper reports an experimental validation of a control algorithm for reduction of higher loads harmonics based on shaft loads measurements. To be able to use shaft loads measurements instead of blade loads, suitable load transformations and the control algorithm based on such transformations were

derived. The experimental validation of the proposed control algorithm took place in wind tunnel at Politecnico di Milano on a scaled fully-controlled wind turbine model. The paper is organised as follows: Brief description of the loads propagation and used coordinate systems is given in Section II. Section III describes the basic individual pitch controller for reduction of the first harmonic of the blade loads. The analysis of the shaft loads frequency components and the proposed control algorithm with appropriate loads transformations are given in Section IV. Finally, in Section V, the experimental setup is described and the obtained results are presented.

II. WIND TURBINE LOADS PROPAGATION

This section presents coordinate systems in which wind turbine structural loads are observed throughout the rest of the paper. The same coordinate systems are used by Germanischer Lloyd for wind turbine certification [7].

A blade coordinate system is defined in the blade root of each blade as shown in Fig. 1 and it is rotating together with the blade, i.e. wind turbine rotor. The z axis of the blade coordinate system has the same direction as the blade, while the x axis has the direction of the wind speed. The y axis is chosen so the resulting coordinate system is right-handed Cartesian coordinate system. The main sources of blade loads are aerodynamic effects, gravity and inertial loads, where aerodynamic and gravity loads have very pronounced oscillatory behaviour caused by rotation of the wind turbine rotor. Since the blade loads are propagated to the rest of wind turbine, reduction of the blade loads significantly reduces the loads on other wind turbine components.

The rotating hub coordinate system has the same direction of the axes as the coordinate system of the first blade, but its origin is in the hub centre instead of the blade root, as shown in Fig. 2. Since the rotating hub coordinate system is rotating with the same speed as blade coordinate systems, the angles among them are constant. Therefore the blade loads are propagated into rotating hub coordinate system as follows:

$$\begin{aligned} M_{r,y} &= \sum_{i=0}^2 M_{y,i} \cos \frac{2\pi}{3}i - \sum_{i=0}^2 M_{z,i} \sin \frac{2\pi}{3}i, \\ M_{r,z} &= \sum_{i=0}^2 M_{z,i} \cos \frac{2\pi}{3}i + \sum_{i=0}^2 M_{y,i} \sin \frac{2\pi}{3}i, \end{aligned} \quad (1)$$

where $M_{y,i}$ and $M_{z,i}$ are blade loads in y and z axes of the i^{th} blade coordinate system, $M_{r,y}$ and $M_{r,z}$ are resulting loads in the rotating hub coordinate system.

The fixed hub coordinate system is the same as the rotating hub coordinate system when the first blade is positioned vertically up (rotor azimuth $\vartheta = 0$). Therefore the loads in the fixed hub coordinate system can be expressed as:

$$\begin{aligned} M_{f,y} &= M_{r,y} \cos \vartheta - M_{r,z} \sin \vartheta, \\ M_{f,z} &= M_{r,y} \sin \vartheta + M_{r,z} \cos \vartheta. \end{aligned} \quad (2)$$

Since the rotor of the observed wind turbine is rotating in the clockwise direction, rotor azimuth angle is defined as positive in the same direction.

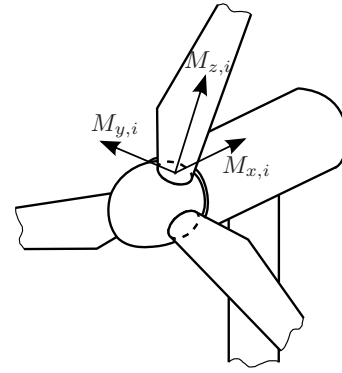

Fig. 1: Structural loads in blade coordinate system.

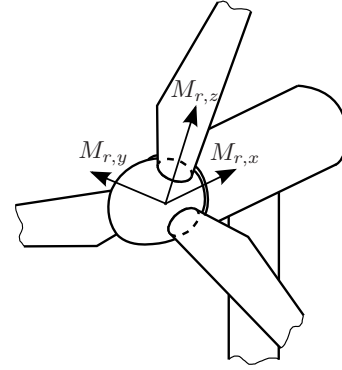

Fig. 2: Structural loads in rotating hub coordinate system.

Note that (1) and (2) do not describe the complete loads on the hub, but only the propagation of the blade loads to the hub. There are additional load components on the hub, but since they are not of the main interest for this paper, they are not written here.

III. BASIC INDIVIDUAL PITCH CONTROL

Due to the rotation of the wind turbine rotor, the structural loads on the blades have emphasized periodic behaviour, where the first harmonic (on the frequency $1p$ – once per revolution) is the most dominant. Therefore the main objective of the individual pitch control is to reduce the first harmonic of the blade loads. Reduction of the first blade loads harmonic also reduces the mean value of the loads on the fixed wind turbine components (i.e. nacelle or tower). The individual pitch control as described in e.g. [8] is based on d-q transformation of the blade loads (where typically blade out-of-plane bending moments $M_{y,i}$ are used):

$$\begin{aligned} M_d &= \frac{2}{3} \sum_{i=0}^2 M_i \cos \vartheta_i, \\ M_q &= \frac{2}{3} \sum_{i=0}^2 M_i \sin \vartheta_i, \end{aligned} \quad (3)$$

where M_i is the blade load and ϑ_i is the azimuth position of the i^{th} blade, while M_d and M_q are loads in d-q coordinate system. Such transformation extracts the information about the first blade loads harmonic, i.e. the mean value of

the transformed loads represents the amplitude of the first blade loads harmonic [9]. Therefore, two controllers in the transformed d-q coordinate system are used for reducing the mean of the transformed loads – one controller for each axis. The three blade pitch reference signals are then obtained by applying the inverse d-q transformation on the controller outputs and adding the collective pitch reference β_c defined by wind turbine rotor speed (i.e. power) controller:

$$\beta_i = \beta_c + \beta_d \cos\left(\vartheta + \frac{2\pi}{3}i\right) + \beta_q \sin\left(\vartheta + \frac{2\pi}{3}i\right), \quad (4)$$

where β_d and β_q are blade pitch references in the d-q coordinate system and β_i is the blade pitch reference of the i^{th} blade.

Note that d-q transformation (3) has similar mathematical formulation as the propagation of the blade loads to the fixed wind turbine components (1) and (2). Therefore, the loads on the fixed wind turbine components can be used for individual pitch control instead of the transformed blade loads, as suggested in [8]. For instance, loads from fixed hub coordinate system can be used for individual pitch control, where the mean of such loads corresponds to the amplitude of the first blade loads harmonic.

Since the goal of this paper is to use shaft measurements for loads reduction, it is quite clear that transformation of the measurements to fixed shaft coordinate system (2) would be convenient for the basic individual pitch control. But such transformed loads are not suitable for reduction of the higher harmonics, so different approach has to be used.

IV. CONTROLLER FOR REDUCTION OF HIGHER LOADS HARMONICS

In this section, the main contribution of the paper is described. To be able to extract the amplitudes of the higher loads harmonics from the shaft loads measurements, first the frequency components of the shaft loads are analysed and then appropriate loads transformation is derived. Afterwards, control algorithm for reduction of higher loads harmonics, based on the derived loads transformation, is proposed.

A. Loads transformation suitable for reduction of higher loads harmonics

In this subsection, load transformation that extracts information needed for reducing each harmonic from shaft measurements is derived. To this aim, the frequency components in shaft loads are analysed, where only deterministic blade load sources (such as the gravity, wind shear, tower shadow) are considered, which produce harmonic loads in steady state. Stochastic effects (such as wind turbulence, wind gusts) can be regarded as control disturbance and therefore they are not directly considered in this analysis. Furthermore, it is assumed that all rotor blades are identical – although this is generally valid assumption, note that any difference between the blades will only generate additional harmonic loading, which the controller will try to compensate.

Since the blades are equally spaced with $\frac{2\pi}{3}$ between each two blades, the loads on them are identical up to phase offset

of $\frac{2\pi}{3}$. The blade loads can be expressed as harmonic signals with the first harmonic on the frequency 1p:

$$\begin{aligned} M_{y,i} &= \sum_{k=0}^{\infty} M_k^y \cos\left(k\vartheta + \varphi_k^y + \frac{2\pi}{3}ki\right), \\ M_{z,i} &= \sum_{k=0}^{\infty} M_k^z \cos\left(k\vartheta + \varphi_k^z + \frac{2\pi}{3}ki\right), \end{aligned} \quad (5)$$

where M_k^y , M_k^z , φ_k^y and φ_k^z are amplitudes and phase angles of k -th harmonic of blade loads.

To examine the frequency components of the rotating hub loads, the blade loads (5) are transformed into rotating hub coordinate system (1). For clarity, only propagation of the blade loads $M_{y,i}$ is written (as if $M_{z,i} = 0$). It is easy to check that propagation of the $M_{z,i}$ has the same characteristics. The propagation of $M_{y,i}$ into rotating hub coordinate system can be written as:

$$\begin{aligned} M_{r,y} &= \frac{3}{2} \sum_{k=0}^{\infty} M_{3k+1}^y \cos\left[(3k+1)\vartheta + \varphi_{3k+1}^y\right] \\ &\quad + \frac{3}{2} \sum_{k=0}^{\infty} M_{3k+2}^y \cos\left[(3k+2)\vartheta + \varphi_{3k+2}^y\right], \\ M_{r,z} &= -\frac{3}{2} \sum_{k=0}^{\infty} M_{3k+1}^y \sin\left[(3k+1)\vartheta + \varphi_{3k+1}^y\right] \\ &\quad + \frac{3}{2} \sum_{k=0}^{\infty} M_{3k+2}^y \sin\left[(3k+2)\vartheta + \varphi_{3k+2}^y\right]. \end{aligned} \quad (6)$$

It is clear from (6) that multiples of the third blade loads harmonic are not present in rotating hub loads. Therefore those harmonics cannot be reduced using shaft loads.

Other blade loads harmonics can be clearly seen in shaft measurements. Note that each harmonic in the rotating hub coordinate system is actually a rotating vector. Therefore the amplitude of each blade loads harmonic can be extracted by transforming measured shaft loads into a coordinate system that is rotating with the same speed as the observed harmonic in respect to rotating hub coordinate system. In such coordinate system, the vector of the transformed harmonic is stationary, which enables us to easily use it for individual pitch control, as it will be shown later.

The direction in which loads harmonics rotate also has to be taken into account. It is obvious from (6) that the harmonics 1p, 4p, 7p... rotate from z axis to y axis, i.e. harmonic $3m+1$ has rotating speed of $-(3m+1)\dot{\vartheta}$ in respect to the rotating hub coordinate system. On the other hand, the harmonics 2p, 5p, 8p... rotate from y axis to z axis, i.e. harmonic $3m+2$ has rotating speed of $(3m+2)\dot{\vartheta}$ in respect to the rotating hub coordinate system. Therefore loads transformation can be defined as:

$$T_N = \begin{bmatrix} \cos N\vartheta & \sin N\vartheta \\ -\sin N\vartheta & \cos N\vartheta \end{bmatrix}, \quad (7)$$

where N represents the rotation speed of the harmonic in respect to rotating hub coordinate system, expressed as the multiple of the rotor speed $\dot{\vartheta}$. In other words, for harmonic $3m+1$, transformation matrix $T_{-(3m+1)}$ should be used,

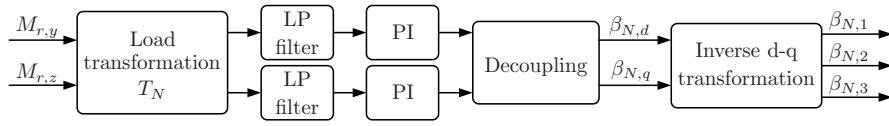

Fig. 3: Control loop for reduction of N^{th} loads harmonic (IPC-Np).

while for harmonic $3m + 2$, transformation T_{3m+2} should be used.

It is clear that for the first harmonic, the transformation matrix T_{-1} actually transforms the loads from rotating hub to fixed hub coordinate system (2) – note that in fact fixed hub coordinate system is “rotating” relative to the rotating hub coordinate system with speed $-\dot{\vartheta}$. Since it is known that loads from the fixed wind turbine parts can be used for reduction of the first harmonic of the blade loads, the proposed transformation (7) is obviously valid for the reduction of the first harmonic.

To show that the transformation is suitable for other harmonics as well, we apply it to the rotating hub loads (6) and calculate the mean value:

$$\frac{1}{2\pi} \int_0^{2\pi} T_N \begin{bmatrix} M_{r,y} \\ M_{r,z} \end{bmatrix} d\vartheta = \begin{cases} \begin{bmatrix} \frac{3}{2} M_N^y \cos \varphi_N^y \\ \frac{3}{2} M_N^y \sin \varphi_N^y \end{bmatrix}, & N = 2, 5, 8 \dots \\ \begin{bmatrix} \frac{3}{2} M_{-N}^y \cos \varphi_{-N}^y \\ -\frac{3}{2} M_{-N}^y \sin \varphi_{-N}^y \end{bmatrix}, & N = -1, -4, -7 \dots \\ \begin{bmatrix} 0 \\ 0 \end{bmatrix}, & \text{otherwise} \end{cases} \quad (8)$$

The mean values of the transformed loads (8) clearly show that transformation (7) can extract the amplitude of all harmonics from the shaft measurements except the multiples of the third harmonic. It can also be seen that the right rotating direction has to be used for each harmonic.

B. Proposed control algorithm

Using transformation (7), the control algorithm for reduction of higher loads harmonics based on shaft measurements can be implemented. The basic controller structure for reduction of a single loads harmonic is shown in Fig. 3. The transformed loads are first filtered and then fed to two PI controllers which try to bring the mean value of the transformed loads (and hence the amplitude of the observed harmonic) to zero value. Since the amplitude of the observed harmonic is converted into mean value in the transformed coordinate system, low-pass filter is used to suppress transformed load oscillations caused by other harmonics. The PI controllers generate the pitch references in the transformed coordinate system, but before they can be transformed into actual blade pitch references, the decoupling has to be made. Namely, the axes in the transformed coordinate system are typically coupled. The amount of coupling depends on the time delays in the system (e.g. caused by blade pitch actuators) – slower dynamical system response, higher rotor speed and higher

sample time generally increase the amount of coupling [10]. The orientation of the measured loads can also have influence on the coupling. As shown in [10], for 1p loads reduction it is sufficient to implement static decoupling (which actually causes decoupling on the frequency of observed harmonic in original coordinate system). The same logic is extended here for the reduction of the higher loads harmonics – for each harmonic to be reduced (i.e. in each transformed coordinate system), only static decoupling is implemented.

After the decoupling, the blade pitch references are obtained by using the inverse d-q transformation:

$$\beta_{N,i} = \beta_{N,d} \cos \left(N\vartheta + \frac{2\pi}{3} Ni \right) + \beta_{N,q} \sin \left(N\vartheta + \frac{2\pi}{3} Ni \right), \quad (9)$$

where $\beta_{N,i}$ is the signal to be added to the i^{th} blade reference signal in order to reduce N^{th} harmonic. Similar control loop has to be implemented for each harmonic to be reduced, as shown in Fig. 4. The final blade pitch reference signal is calculated by adding contribution from each loads controller to the collective blade pitch reference signal (defined by the collective wind turbine rotor speed controller):

$$\beta_i = \beta_c + \sum_N \beta_{N,i}. \quad (10)$$

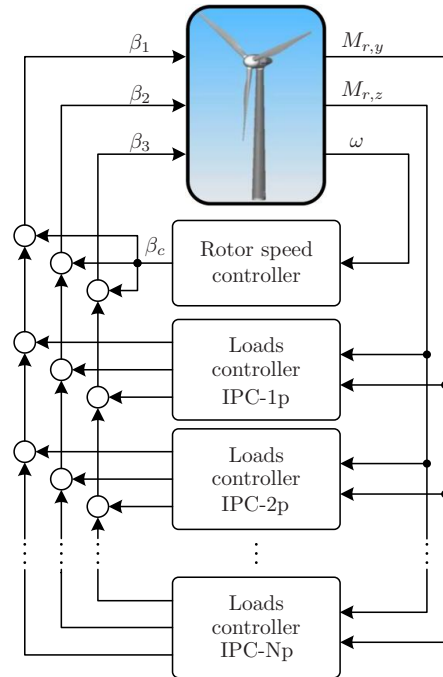

Fig. 4: Controller for the reduction of higher loads harmonic.

Note that filtering of the transformed loads (see Fig. 3) limits the frequency bandwidth of each loads controller

around the harmonic they are designed to reduce and therefore no interference among different controllers is expected. Furthermore, since the multiples of the third harmonic are not being reduced, the described controllers for load reduction will never change the collective pitch angle and therefore they will not interfere with wind turbine rotor speed control:

$$\frac{1}{3} \sum_{i=0}^2 \beta_i = \beta_c. \quad (11)$$

V. EXPERIMENTAL VALIDATION OF THE PROPOSED CONTROL ALGORITHM

The described control algorithm is experimentally validated on a scaled wind turbine model in wind tunnel at Politecnico di Milano. Brief description of the wind turbine model, wind tunnel and the experiments made are given in the following subsections. The experimental results are presented at the end of this section.

A. Wind turbine model and wind tunnel

Wind turbine model developed at Politecnico di Milano represents a scaled version of the a real 3 MW wind turbine. It is fully-controlled wind turbine model with ability for torque control and individual pitching of the blades, just as modern multi-megawatt wind turbines.

The scaled wind turbine model has been specially conceived so as the scaled and full scale wind turbine have the same values of tip speed ratio (ensuring the same kinematics), the same ratio of aerodynamic to inertial forces (i.e. the same Lock number) and the same relative placement of harmonic excitations and natural frequencies (i.e. same Campbell diagram). Compromise between the Reynolds number mismatch and the speed-up of the system has been made in order to increase the quality of the aerodynamics of the scaled model while avoiding an excessive increase in the needed control bandwidth.

The scaling factors used for the model wind turbine design to achieve the desired properties of the full scale wind turbine are presented in Table I.

The model wind turbine control system is implemented on Bachmann M1 real-time controller (<http://www.bachmann.info>). Both basic wind turbine rotor speed (i.e. power) controller and the proposed controller for load reduction are implemented and tested. The sampling time of those controllers is chosen to be 8 ms, while the low-level control of the actuators (generator torque control and blade pitch control) and data acquisition are done at faster sample rates (up to 2.5 kHz).

The model wind turbine nacelle-hub layout (without nacelle cover) is shown in Fig. 5. The more detailed description of the scaled wind turbine model can be found in [11], [12].

The wind tunnel at Politecnico di Milano, where experimental tests took place, has two test sections – aeronautical and civil. The wind turbine control tests took place in civil test section of the wind tunnel, which is 14 m wide, 4 m high and 35 m long. The maximum wind speed in the civil test section is 14 m/s, with turbulence intensity less than 2%. To

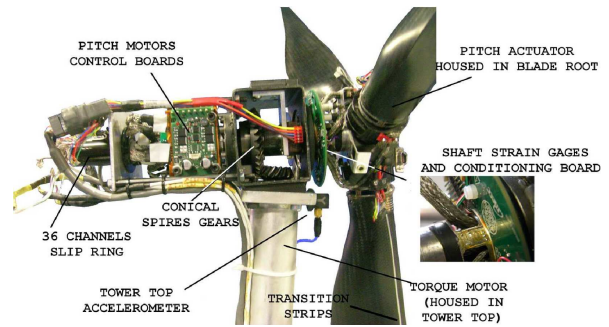

Fig. 5: General arrangement of the hub and nacelle systems of the aero-servo-elastic model.

TABLE I: Scaling factors used for the design of the wind turbine model.

Quantity	Scaling factor
Length	1 : 45
Time	1 : 22.84
Speed	1 : 1.97
Power	1 : 15477
Rotor speed	22.84 : 1
Torque	1 : 353574
Reynolds	1 : 88.64
Froude	11.6 : 1
Mach	1 : 1.97

obtain the desired wind characteristics, it is possible to use passive turbulence generators and to place smaller elements on the floor which increase its roughness.

B. Experimental results

The proposed control algorithm is used for reduction of the first and second harmonic (1p and 2p). To excite the second loads harmonic, the wind turbine was held in the wake of another identical model during the tests. Since the nominal wind turbine rotor speed is 380 rpm (chosen because of the scaling reasons), it means that in order to reduce the first two harmonics, the blade pitch has to continuously oscillate on frequencies 6.3 Hz and 12.7 Hz. It was decided against using the proposed control algorithm on even higher harmonics to avoid overstressing of the blade pitch actuators. Note that the frequency of the first harmonic on the modern multi-megawatt wind turbines is typically under 0.5 Hz, and is getting lower as the wind turbines grow in size, making the implementation of the higher loads harmonics feasible.

Before the control algorithm could be tested, coupling between the axes for each harmonic had to be identified. To this goal, several different blade pitch references in the transformed coordinate systems were set and the loads were recorded. Since only static decoupling is to be used, it was sufficient to calculate static gains between the blade pitch references and the loads in both axes of the transformed coordinate systems. The calculated gains are then used for achieving decoupling between the axes in each transformed coordinate system.

Once the decoupling had been implemented, several experiments for validation of the proposed controller have

TABLE II: Experimental results for the shaft loads, blade pitch angle and power output for three control cases.

	Normalised shaft loads					Normalised blade pitch					Normalised power output				
	0p	1p	2p	3p	4p	0p	1p	2p	3p	4p	0p	1p	2p	3p	4p
No IPC	1.14	1.00	0.95	0.08	0.04	0.11	0.05	0.00	0.00	0.00	1.00	0.01	0.01	0.00	0.01
IPC – 1p	1.14	0.38	0.71	0.14	0.05	0.18	1.00	0.02	0.02	0.00	1.00	0.01	0.00	0.00	0.01
IPC – 1p, 2p	1.20	0.22	0.15	0.22	0.07	0.19	1.03	0.45	0.02	0.01	1.01	0.01	0.01	0.00	0.01

been made – experiments with only collective pitch control (No IPC), experiments with collective and individual pitch control for reduction of the first harmonic (IPC – 1p) and experiments with collective and individual pitch control for reduction of the first two harmonics (IPC – 1p, 2p). Obtained results are presented in Table II. Note that the results are normalised – shaft loads and blade pitch are normalised in respect to the amplitude of 1p harmonic, while the wind turbine power is normalised in respect to the mean power output. It can be clearly seen from the shaft loads that proposed control algorithm is capable of reducing the first and the second harmonic from the shaft measurements. The reduction of the loads harmonics is achieved through higher pitch activity on frequencies 1p and 2p. It should also be noted that there are no significant changes in the wind turbine power output regardless of the control algorithm used.

For better understanding of the way the proposed control algorithm works, shaft loads and blade pitch angles are shown in Fig. 6. At the beginning of the figure, individual pitch control for reducing the first two harmonics (IPC – 1p, 2p) is active. Then in the middle of the figure, the reduction of the second harmonic is deactivated, while the reduction of the first harmonic is still being active (IPC – 1p). Finally, the end of the figure shows only collective pitch control (No IPC). It can be clearly seen how the amplitude of the loads rises as the individual pitch control is being deactivated. At the same time, blade pitch becomes less active – and with only collective pitch control, all the blades are pitched identically.

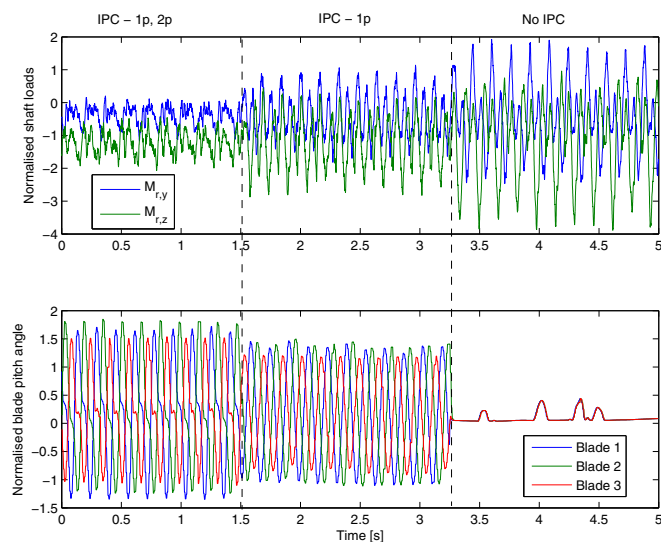

Fig. 6: Shaft loads and blade pitch response to different control algorithms.

VI. CONCLUSION

This paper presents the control algorithm for reduction of wind turbine higher loads harmonics using shaft measurements. First, the shaft loads frequency analysis is given and the transformation of the measured loads suitable for control loop is proposed. The described algorithm is capable of reducing any loads harmonics except for the multiples of the third harmonic, since they are not present in the shaft loads. The proposed control algorithm is implemented on the scaled wind turbine model developed at Politecnico di Milano and it is experimentally tested in wind tunnel. Wind tunnel tests demonstrated that proposed control algorithm is able to reduce desired harmonics from the loads without deterioration of the wind turbine power output.

ACKNOWLEDGEMENTS

This research has been financially supported by Vestas Wind Systems A/S; and by project “ACROSS – Centre of Research Excellence for Advanced Cooperative Systems” (FP7 project No. 285939). This support is gratefully acknowledged. The authors also wish to thank Bachmann Electronic GmbH for their contribution of the development of the real-time control system.

REFERENCES

- [1] European Wind Energy Association, “Wind in power: 2010 European statistics,” 2011.
- [2] European Environment Agency, “Europe’s onshore and offshore wind energy potential,” 2009.
- [3] European Renewable Energy Council, “Re-thinking 2050: A 100% renewable energy vision for the European Union,” 2010.
- [4] E. Hau, *Wind Turbines: Fundamentals, Technologies, Application, Economics*, 2nd ed. Springer, 2006.
- [5] T. van Engelen, “Design model and load reduction assessment for multi-rotational mode individual pitch control (higher harmonics control),” in *European Wind Energy Conference*, Athens, Greece, February–March 2006.
- [6] K. Selvam, S. Kanev, J. W. van Wingerden, T. van Engelen, and M. Verhaegen, “Feedback-feedforward individual pitch control for wind turbine load reduction,” *International Journal of Robust and Nonlinear Control*, vol. 19, no. 1, pp. 72–91, 2009.
- [7] Germanischer Lloyd, “Rules and Guidelines IV: Industrial Services, Part I – Guideline for the Certification of Wind Turbines,” 2003.
- [8] E. A. Bossanyi, “Individual blade pitch control for load reduction,” *Wind Energy*, vol. 6, no. 2, pp. 119–128, 2003.
- [9] V. Petrović, M. Jelavić, and N. Perić, “Identification of wind turbine model for individual pitch controller design,” in *International Universities Power Energy Conference*, Padova, Italy, September 2008.
- [10] M. Jelavić, V. Petrović, and N. Perić, “Estimation based individual pitch control of wind turbine,” *Automatika*, vol. 51, no. 2, pp. 181–192, 2010.
- [11] C. L. Bottasso, F. Campagnolo, A. Croce, and L. Maffeni, “Development of a wind tunnel model for supporting research on aero-servo-elasticity and control of wind turbines,” in *International Conference on Wind Engineering*, Amsterdam, Netherlands, July 2011.
- [12] C. L. Bottasso, F. Campagnolo, and V. Petrović, “Wind tunnel testing of scaled wind turbine model: beyond aerodynamics,” *Renewable Energy*, 2013, under review.