

Voltage Stability and Robustness for Microgrid Systems

Le Yi Wang¹, Michael Polis², Caisheng Wang³, Feng Lin⁴

Abstract—Voltage stability is of essential importance for power grids. The emergence of distributed energy generators, controllable loads, and local-area energy storage capabilities have introduced new scenarios for distribution networks in which classical frameworks for voltage stability may be inadequate. This paper introduces a control-theoretic framework for studying voltage stability and its robustness, as well as optimal power management in distribution systems composed of networked microgrids. The framework involves descriptions of the loads and generators by nonlinear state space models and the network connections by a set of topology-based algebraic equations. The integration of the combined system leads to a general nonlinear state space model for the microgrid systems. Simplified microgrids are used to illustrate the concepts.

I. INTRODUCTION

As the power industry has become more deregulated and power grids are expanded with distributed energy generators, the concept of microgrids [4], [9] has gained traction recently as a suitable framework to represent area distribution networks that include local generators of different types (solar, wind, micro-turbine, fuel cells), dynamic and manageable loads (PHEV, smart meters), and energy storage systems (battery, super-capacitor, flywheel, biomass, heat pumps, pumped hydro). With more distributed renewable sources, controllable loads, and energy storage systems, voltage stability has become one of most critical issues in smart grid and microgrid implementations, due to more volatile generation and loads, and more sophisticated control requirements [10], [18], [26], [24].

Traditionally, voltage stability was studied for transmission systems over a large area network under normal and contingent conditions [1], [2], [3], [6], [15], [19], [25]. Many methods have been proposed to address this important issue [11]. Most approaches/methods have been focused on the development of equivalent model and voltage indices under simplified conditions on loads and networks. Rigorous studies of voltage stability using established theoretical methodologies can be found in [7], [12], [13], [14], [20]. For local small-signal stability, state space models and Lyapunov indirect stability have been used as a basic framework in analyzing voltage stability [19]. Classical voltage stability

is mostly concerned with generation and transmission networks. Detailed models of load dynamics and their impact on stability are yet to be investigated. On the other hand, the emergence of distributed energy generators, controllable loads, and local-area energy storage capabilities have introduced new scenarios in which distribution networks become more and more sophisticated.

This paper lays out a control-theoretic foundation for voltage stability and its robustness in microgrid systems. In our framework, load and generator dynamics are represented by node dynamic systems and their inter-connections are modeled by distribution links of relatively small distances. Interactions of subsystems in such a grid-linked system result in a complicated nonlinear dynamic system. The uniqueness of microgrids, as compared to traditional transmission networks, is the intimate interaction of the multiple load dynamics within a relatively compact network. Consequently, stability analysis must be treated as an integrated system. Although there exists extensive work on voltage stability and several useful indices have been introduced for characterizing voltage stability [16], [23], [27], [28], interactions among load dynamics and grid topologies were not comprehensively studied. Voltage robust stability against grid parameter uncertainties was investigated using typical tools from robust control methodologies, including H^∞ sensitivity minimization, loop shaping, μ -synthesis, or structured singular values [5], [8], [21], [22]. Key uncertainties in microgrids with renewable generators are load disturbances. Consequently, different approaches are needed for grid voltage robustness. This paper introduces a framework in which voltage stability, network robustness, and optimal power management for sustained voltage stability can be rigorously studied and optimization strategies can be designed. The framework involves descriptions of the loads and generators by nonlinear state space models and the network connections by a set of topology-based algebraic equations. The integration of the combined system leads to a general nonlinear state space model for the microgrid systems. Lyapunov local stability for nonlinear state space systems [17] becomes a viable foundation to understand stability and robustness of the microgrid systems against load variations. At present, the robustness measures are limited to steady-state stability with small perturbations. Transient stability or “global” stability of large operating ranges which will be better treated by Lyapunov direct methods or other nonlinear control approaches remains largely an open problem.

The rest of the paper is organized into the following sections. Section III establishes the generic framework for a network of microgrids in which voltage stability can be

¹L.Y. Wang is with Department of Electrical and Computer Engineering, Wayne State University, Detroit, MI 48202, lywang@ece.eng.wayne.edu.

²M. Polis is with Dept of ISE, Oakland University Rochester, MI 48309, polis@oakland.edu.

³C. Wang is with Department of Electrical and Computer Engineering, Wayne State University, Detroit, MI 48202, cwang@wayne.edu.

⁴F. Lin is with Department of Electrical and Computer Engineering, Wayne State University, Detroit, MI 48202, flin@ece.eng.wayne.edu.

analyzed rigorously based on load and generator dynamics and network connections and conditions. To be more concrete in demonstrating the capability of the framework, Section IV illustrates the main approaches with a basic network that includes one generator and two loads. Detailed derivations on voltage stability conditions are given. Section V is concentrated on power management and voltage stability margins. Three robustness margins are introduced to capture different configurations and load types in microgrids. Finally, the paper concludes with some remarks on the potential usage of this framework.

II. GENERAL PROBLEM FORMULATION

Consider a network of microgrids shown in Fig. 1. All voltages and currents are represented by their phasors, and line impedances are indicated also. $\vec{E} = E\angle 0$ is the equivalent generator from the utility grid to the network and is used as a reference point. Generally, we will use $\vec{V}_k = V_k\angle\delta_k$ to represent a voltage phasor; and $\vec{I}_k = I_k\angle\theta_k$ to represent a current phasor. During transient time intervals when magnitudes or angles of voltages and currents change with time, we use the notation $\vec{V}_i(t) = V_i(t)\angle\delta_i(t)$. This should not be confused with the actual voltage time function which is a sine wave of a given frequency. This paper will not deal with the issue of frequency regulation. Hence, the frequency is assumed to be a fixed constant.

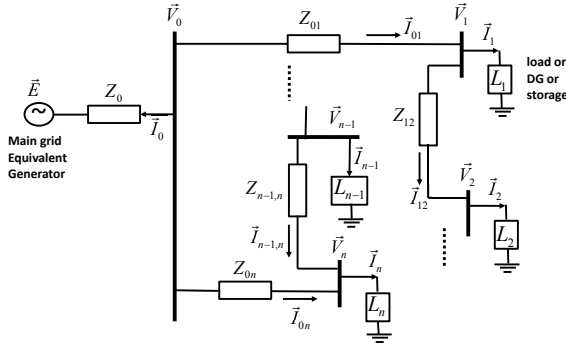

Fig. 1. A network of microgrids

A. State Space Models

For a unified system treatment, we will use state space models. To facilitate this formulation, in dynamic system representations which are traditionally confined to real values, we will use the lower-case letters to represent vectors, that are equivalent to the phasor representations, to avoid complex values:

$$e = \begin{bmatrix} E \\ 0 \end{bmatrix}, v_k = \begin{bmatrix} V_k \\ \delta_k \end{bmatrix}, i_k = \begin{bmatrix} I_k \\ \theta_k \end{bmatrix}, k = 0, 1, \dots, n. \quad (1)$$

Since $\vec{V}_k^* = V_k\angle -\delta_k$, we will use the notation

$$v_k^+ = \begin{bmatrix} V_k \\ -\delta_k \end{bmatrix}$$

to represent the counterpart of complex conjugate for a phasor in the vector notation.

The networked system consists of a main grid connecting point and n nodes. The main grid is represented by an equivalent generator and an internal impedance. Depending on the actual network configuration, each node may represent a motor, a house, a battery storage device, an electric vehicle, a wind turbine, a solar panel, etc. Or, each node may be a microgrid itself, representing a cluster of loads and generators in a region. So, the word ‘‘load’’ in this paper will be used in a broader sense.

Each node will be a dynamic system itself. For studies on voltage stability, for the k th-node dynamic system the input is v_k and the output is i_k , both are vectors as defined in (1), and its dynamics are expressed by a nonlinear state space model of dimension n_k and state x_k

$$\begin{cases} \dot{x}_k = f_k(x_k, v_k) \\ i_k = g_k(x_k, v_k) \end{cases} k = 1, \dots, n. \quad (2)$$

On the other hand, the network links define algebraic relationships among node voltages, node currents, and link currents. Since link currents are direct functions of bus voltages, these relationships will be represented by the algebraic vector equations

$$i_k = h_k(v_0, v_k), k = 1, \dots, n. \quad (3)$$

and

$$v_0 = h(i_1, \dots, i_n, e). \quad (4)$$

For example, for the system in Fig. 1 we have, in the phasor notation, $\vec{I}_{jk} = \frac{\vec{V}_j - \vec{V}_k}{Z_{jk}}$, $\vec{V}_0 = \vec{E} - \left(\sum_{k=1}^n \vec{I}_{0k}\right) Z_E$, each of which can be written as two algebraic equations in the vector notation. It follows that

$$i_k = h_k(v_0, v_k) = h_k(h(i_1, \dots, i_n, e), v_k), k = 1, \dots, n. \quad (5)$$

Collectively, by denoting

$$\mathbf{I} = \begin{bmatrix} i_1 \\ \vdots \\ i_n \end{bmatrix}, \mathbf{V} = \begin{bmatrix} v_1 \\ \vdots \\ v_n \end{bmatrix}, \mathbf{X} = \begin{bmatrix} x_1 \\ \vdots \\ x_n \end{bmatrix}$$

we may express (2) and (5) compactly as

$$\begin{cases} \dot{\mathbf{X}} = F(\mathbf{X}, \mathbf{V}) \\ \mathbf{I} = G(\mathbf{X}, \mathbf{V}) \end{cases} \quad (6)$$

and

$$\mathbf{I} = H(\mathbf{I}, \mathbf{V}, e). \quad (7)$$

(7) is an implicit equation on \mathbf{V} . Although for numerical computations, we may not need its explicit solution from (7), the existence of the solution is guaranteed due to its physical interpretation as an electric grid network, see [3]. For analysis, let such a solution be denoted by

$$\mathbf{V} = Q(\mathbf{I}, e). \quad (8)$$

This, together with (6), leads to $\mathbf{V} = Q(\mathbf{I}, e) = Q(G(\mathbf{X}, \mathbf{V}), e)$, which defines a mapping $\mathbf{V} = S(\mathbf{X}, e)$.

These derivations result in a general expression in state space for the network as

$$\begin{cases} \dot{\mathbf{X}} = F(\mathbf{X}, \mathbf{V}) \\ \mathbf{V} = S(\mathbf{X}, e) \end{cases} \quad (9)$$

This state space model for the entire network of microgrids may be viewed as the closed-loop system in which the node dynamics $\dot{\mathbf{X}} = F(\mathbf{X}, \mathbf{V})$ define the open-loop unconnected subsystems and the network connections insert a state feedback by $\mathbf{V} = S(\mathbf{X}, e)$.

B. Local Lyapunov Stability

The plant-feedback pair in (9) results in the closed-loop system

$$\dot{\mathbf{X}} = F(\mathbf{X}, \mathbf{V}) = F(\mathbf{X}, S(\mathbf{X}, e)). \quad (10)$$

Stability of the network is inherently the Lyapunov stability of the closed-loop system (10). It is noted that load types and load control strategies affect the open-loop dynamics and the network topology and link impedances define the state feedback. They jointly determine the network stability.

Although (10) provides a conceptual understanding of the nature of stability analysis, it may not be computationally desirable since it requires explicit elimination of all intermediate variables. For stability analysis, we may use the original implicit forms.

By (6) and (7), $\mathbf{I} = G(\mathbf{X}, \mathbf{V})$, $\mathbf{I} = H(\mathbf{I}, \mathbf{V}, e)$, namely $G(\mathbf{X}, \mathbf{V}) = H(G(\mathbf{X}, \mathbf{V}), \mathbf{V}, e)$ which is the implicit form of a state feedback

$$H(\mathbf{X}, \mathbf{V}) = 0. \quad (11)$$

Consequently, the feedback system (9) can be written, without solving for explicit functional relationships, as

$$\begin{cases} \dot{\mathbf{X}} = F(\mathbf{X}, \mathbf{V}) \\ H(\mathbf{X}, \mathbf{V}) = 0 \end{cases} \quad (12)$$

For stability analysis, we first solve for the equilibrium points from

$$\begin{cases} F(\mathbf{X}, \mathbf{V}) = 0 \\ H(\mathbf{X}, \mathbf{V}) = 0 \end{cases} \quad (13)$$

Let $(\mathbf{X}_0, \mathbf{V}_0)$ be an equilibrium point.

Compute the corresponding Jacobian matrices

$$\begin{aligned} F_x &= \frac{\partial F}{\partial \mathbf{X}} \bigg|_{(\mathbf{x}_0, \mathbf{v}_0)}, F_v = \frac{\partial F}{\partial \mathbf{V}} \bigg|_{(\mathbf{x}_0, \mathbf{v}_0)}, \\ H_x &= \frac{\partial H}{\partial \mathbf{X}} \bigg|_{(\mathbf{x}_0, \mathbf{v}_0)}, H_v = \frac{\partial H}{\partial \mathbf{V}} \bigg|_{(\mathbf{x}_0, \mathbf{v}_0)}. \end{aligned}$$

Denote $\tilde{\mathbf{X}} = \mathbf{X} - \mathbf{X}_0$ and $\tilde{\mathbf{V}} = \mathbf{V} - \mathbf{V}_0$. The linearized perturbation relationship of $H(\mathbf{X}, \mathbf{V}) = 0$ is $H_x \tilde{\mathbf{X}} + H_v \tilde{\mathbf{V}} = 0$. By the Taylor expansion, we have the linearized perturbation system as

$$\dot{\tilde{\mathbf{X}}} = F_x \tilde{\mathbf{X}} + F_v \tilde{\mathbf{V}} = (F_x - F_v H_v^{-1} H_x) \tilde{\mathbf{X}}.$$

Consequently, the local stability at $(\mathbf{X}_0, \mathbf{V}_0)$ is determined by the matrix

$$J = F_x - F_v H_v^{-1} H_x.$$

In other words, all eigenvalues of J must be in the open left-half plane.

III. VOLTAGE STABILITY ANALYSIS FOR RADIAL NETWORKS OF RESISTANCE MICROGRIDS

To convey the basic ideas more concisely and provide explicit solutions, we now consider the special case of a resistance network of radial topology, shown in Fig. 2. Here the line losses and loads are all resistive. Consequently, all voltages and currents are in phase, and hence are represented by their RMS values only.

Suppose that the loads are of power types. Let the target power consumptions for the loads L_1, \dots, L_n be P_1^0, \dots, P_n^0 , respectively. Then generically, we may represent the load dynamics by

$$\dot{I}_i = -f_i(V_i)(V_i I_i - P_i^0), i = 1, \dots, n. \quad (14)$$

The functions $f_i(V_i) > 0$ are positive functions, and their forms depend on the actual load features and their control systems. The load subsystems (14) simply indicate that when network variations and disturbances cause actual power changes, these constant-power loads will adjust the current intakes to maintain their desired power levels.

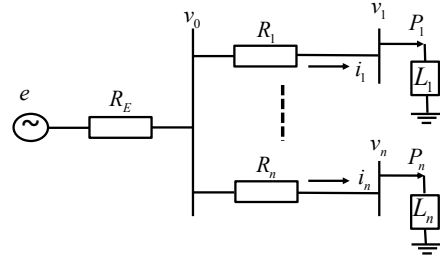

Fig. 2. A resistance radial network

The network equations are

$$V_i = E - (I_1 + \dots + I_n)R_E - I_i R_i, \quad i = 1, \dots, n. \quad (15)$$

Or equivalently,

$$V_i = E - (R_i + R_E)I_i - R_E \sum_{j \neq i} I_j, \quad i = 1, \dots, n. \quad (16)$$

$$\text{Define } V = \begin{bmatrix} V_1 \\ \vdots \\ V_n \end{bmatrix}, I = \begin{bmatrix} I_1 \\ \vdots \\ I_n \end{bmatrix}, B = \begin{bmatrix} 1 \\ \vdots \\ 1 \end{bmatrix},$$

$$M = \begin{bmatrix} R_1 + R_E & R_E & \cdots & R_E \\ R_E & R_2 + R_E & \cdots & R_E \\ \vdots & \vdots & \ddots & \vdots \\ R_E & R_E & \cdots & R_n + R_E \end{bmatrix}.$$

We have $V = -MI + BE$. Further denote $F(V) = \text{diag}[f_i(V_i)]$, $C_i = [0, \dots, 1, \dots, 0]$ with the 1 at the i th

position. It follows that

$$\begin{aligned}\dot{V} &= -M\dot{I} = -M \begin{bmatrix} -f_1(V_1)(V_1 I_1 - P_1^0) \\ \vdots \\ -f_n(V_n)(V_n I_n - P_n^0) \end{bmatrix} \\ &= MF(V) \begin{bmatrix} V^T Q_1 V + V^T K_1 - P_1^0 \\ \vdots \\ V^T Q_n V + V^T K_n - P_n^0 \end{bmatrix}\end{aligned}$$

where $Q_i = -C_i^T C_i M^{-1}$, $K_i = C_i^T C_i M^{-1} B E$, $i = 1, \dots, n$.

Since M and $F(V)$ are positive definite, for the given P_1^0, \dots, P_n^0 , the equilibrium point of the above voltage dynamic system can be solved from

$$V^T Q_i V + V^T K_i = P_i^0, \quad i = 1, \dots, n. \quad (17)$$

Let the equilibrium point be V^0 . Then, the Jacobian matrix of the system at the equilibrium point is

$$J(P^0) = MF(V^0) \begin{bmatrix} 2(V^0)^T Q_1 + K_1^T \\ \vdots \\ 2(V^0)^T Q_n + K_n^T \end{bmatrix}. \quad (18)$$

The voltage stability at the equilibrium point is determined by the eigenvalues of $J(P^0)$: P^0 belongs to the stable region if all eigenvalues of $J(P^0)$ are in the open left-half plane [17], [19].

Remark 1: It should be noted that although both M and $F(V^0)$ are positive definite, they do have substantial impact on stability. The following example illustrates this point.

Consider the following two matrices

$$A = \begin{bmatrix} 0 & 1 & 0 \\ 0 & 0 & 1 \\ -1 & -2 & -3 \end{bmatrix}, D = \begin{bmatrix} 4 & 0 & 0 \\ 0 & 10 & 0 \\ 0 & 0 & 0.5 \end{bmatrix}.$$

The eigenvalues of A are $-2.3247, -0.3376 + 0.5623i, -0.3376 - 0.5623i$. So, A is a stable matrix. D is a positive definite matrix. But the eigenvalues of DA are $-1.8704, 0.1852 + 3.2647i, 0.1852 - 3.2647i$, which is unstable.

On the other hand, second-order systems are different. Consider

$$A = \begin{bmatrix} 0 & 1 \\ -a & -b \end{bmatrix}, D = \begin{bmatrix} d_1 & 0 \\ 0 & d_2 \end{bmatrix}.$$

For any $a > 0$ and $b > 0$, A is stable. Also, for any $d_1 > 0$ and $d_2 > 0$, D is positive definite. Now,

$$DA = \begin{bmatrix} 0 & d_1 \\ -ad_2 & -bd_2 \end{bmatrix}$$

whose characteristic polynomial is $\lambda^2 + bd_2\lambda + ad_1d_2$ which remains stable.

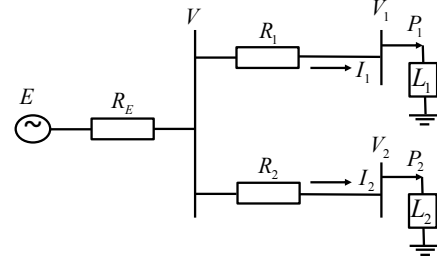

Fig. 3. A two-load three-bus network

IV. CASE STUDY: TWO-LOAD NETWORKS

Consider the network of two loads and three buses in Fig. 3. It consists of one generator and two loads interconnected by a three-bus network.

The target power consumptions for the loads L_1 and L_2 are P_1^0 and P_2^0 , respectively. The load dynamics are

$$\begin{cases} \dot{I}_1 = -f_1(V_1)(V_1 I_1 - P_1^0) \\ \dot{I}_2 = -f_2(V_2)(V_2 I_2 - P_2^0) \end{cases}. \quad (19)$$

Here, the functions $f_1(V_1) > 0$ and $f_2(V_2) > 0$. On the other hand, the network equations are

$$\begin{cases} V_1 = E - (I_1 + I_2)R_E - I_1 R_1 \\ V_2 = E - (I_1 + I_2)R_E - I_2 R_2 \end{cases}, \quad (20)$$

which lead to

$$\begin{cases} V_1 = E - (R_1 + R_E)I_1 - R_E I_2 \\ V_2 = E - R_E I_1 - (R_2 + R_E)I_2 \end{cases}. \quad (21)$$

Following the same notation and derivations of Section III, we have

$$\dot{V} = MF(V) \begin{bmatrix} V^T Q_1 V + V^T K_1 - P_1^0 \\ V^T Q_2 V + V^T K_2 - P_2^0 \end{bmatrix}$$

where

$$\begin{aligned}Q_1 &= -C_1^T C_1 M^{-1} \\ &= - \begin{bmatrix} 1 & 0 \\ 0 & 0 \end{bmatrix} \frac{\begin{bmatrix} R_2 + R_E & -R_E \\ -R_E & R_1 + R_E \end{bmatrix}}{R_1 R_2 + (R_1 + R_2)R_E} \\ &= - \frac{\begin{bmatrix} R_2 + R_E & -R_E \\ 0 & 0 \end{bmatrix}}{R_1 R_2 + (R_1 + R_2)R_E}\end{aligned}$$

$$Q_2 = -C_2^T C_2 M^{-1} = - \frac{\begin{bmatrix} 0 & 0 \\ -R_E & R_1 + R_E \end{bmatrix}}{R_1 R_2 + (R_1 + R_2)R_E}$$

$$K_1 = C_1^T C_1 M^{-1} B E = - \frac{\begin{bmatrix} R_2 \\ 0 \end{bmatrix} E}{R_1 R_2 + (R_1 + R_2)R_E}$$

$$K_2 = C_2^T C_2 M^{-1} B E = - \frac{\begin{bmatrix} 0 \\ R_1 \end{bmatrix} E}{R_1 R_2 + (R_1 + R_2)R_E}.$$

For the given P_1^0 and P_2^0 , the equilibrium point of the above voltage dynamic system can be solved from

$$\begin{cases} V^T Q_1 V + V^T K_1 = P_1^0 \\ V^T Q_2 V + V^T K_2 = P_2^0 \end{cases}. \quad (22)$$

That is,

$$\begin{cases} -(R_2 + R_E)V_1^2 + R_E V_1 V_2 - R_2 E V_1 = P_1^0 \\ -(R_1 + R_E)V_2^2 + R_E V_1 V_2 - R_1 E V_2 = P_2^0 \end{cases}. \quad (23)$$

Let the equilibrium point be V^0 . Then, the Jacobian matrix of the system at the equilibrium point is

$$J(P^0) = MF(V^0) \begin{bmatrix} 2(V^0)^T Q_1 + K_1^T \\ 2(V^0)^T Q_2 + K_2^T \end{bmatrix}. \quad (24)$$

Example 1: Suppose that a network has the following parameters: $E = 10$ kV, $R_E = 3$ ohm, $R_1 = 3$ ohm, $R_2 = 3$ ohm, $f_1 = 1$, $f_2 = 5$. The load stability region for this network in terms of steady-state load powers is shown in Fig. 4.

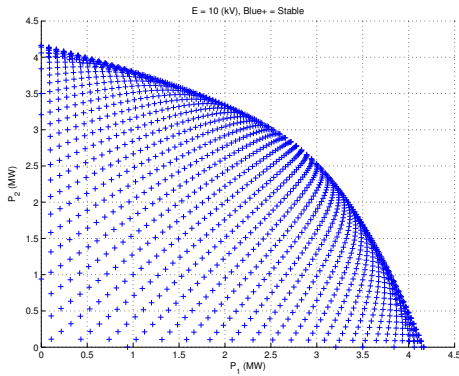

Fig. 4. Voltage stability: The region of stability with steady-state load powers

V. OPTIMAL POWER GENERATION AND VOLTAGE STABILITY MARGINS

A. Optimal Power Generation

For the network in Fig. 2, what is the maximum load power that can be supported on this distribution system? This can be formally stated in the following optimization problem. Let Ω be the set of P for which $J(P)$ is stable.

$$\begin{cases} p_{max} = \max \sum_{i=1}^n P_i \\ s.t. P \in \Omega \end{cases} \quad (25)$$

Example 2: For the same system as in Example 1, the total load $P_1 + P_2$ is plotted with different values, on top of the stability region. It is seen that the maximum load that can be supported by this network is the line that is tangent to the boundary of the stability region, shown in Fig. 5.

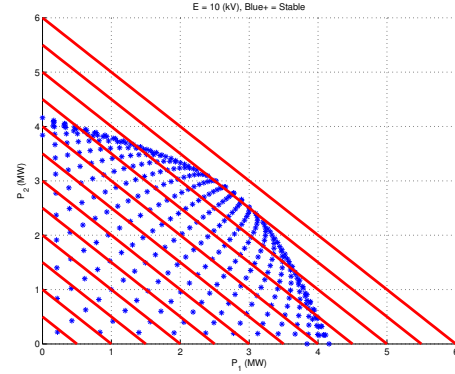

Fig. 5. Maximum total load for the network in Example 1.

B. Stability Margins

We introduce the following three stability margins. The robust stability margins are defined in terms of uncertainties in loads. This is different from traditional robust stability literature that mostly treats uncertainties from plant models [5], [8], [21], [22].

Suppose that the loads of the network are $P = [P_1, \dots, P_n]^T$. The total load is $p = P^T \mathbb{1} = \sum_{i=1}^n P_i$, where $\mathbb{1} = [1, 1, \dots, 1]^T$ of compatible dimension. For a maximum load increase $\delta > 0$, the set $B(\delta)$ denotes all possible load assignments whose total load increase is bounded by δ ,

$$B(\delta) = \{d = [d_1, \dots, d_n]^T : d_i \geq 0, i = 1, \dots, n; d^T \mathbb{1} \leq \delta\}.$$

We use the set notation $P + B(\delta) = \{P + d : d \in B(\delta)\}$.

The following stability margins are introduced. Since the stability set Ω is an open set¹, in the following definitions we must use sup in place of max. This simply means that the stability margin may not be attained.

- 1) Given the current load assignment P ,

$$\delta(P) = \sup\{\delta : P + B(\delta) \subseteq \Omega\}. \quad (26)$$

$\delta(P)$ is called the ‘‘voltage stability margin’’ at P . This stability margin characterizes the total tolerable load increase of the network under any possible assignment without destabilizing the network.

- 2) Given the current load assignment P with the total load $p = P^T \mathbb{1}$,

$$\delta_{opt}(p) = \sup\{\delta(P) : P^T \mathbb{1} = p\}. \quad (27)$$

$\delta_{opt}(p)$ is called the ‘‘optimal voltage stability margin’’ of load p . This stability margin means that if the current loads, but not the future load increases, can be optimally re-assigned to enhance robustness of the network, the maximum achievable stability margin is $\delta_{opt}(p)$.

- 3) Given the current load assignment P with the total load $p = P^T \mathbb{1}$,

$$\delta_{max}(p) = p_{max} - p. \quad (28)$$

$\delta_{max}(p)$ is called the ‘‘maximum load margin’’ of load p . This margin means that if the current loads and all

¹We do not consider a marginally stable system as a stable system here.

future load increases can be optimally re-assigned to support voltage stability of the network, the maximum load increase that can be tolerated by the network is $\delta_{max}(p)$.

The stability margins are illustrated in Fig. 6. Clearly, $\delta \leq \delta_{opt} \leq \delta_{max}$.

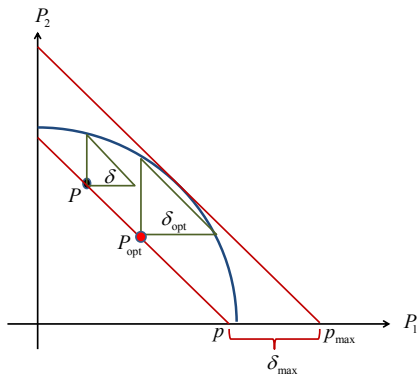

Fig. 6. Voltage stability margins.

VI. CONCLUDING REMARKS

This paper introduces a general framework for studying voltage stability and robustness in microgrid systems. The framework involves descriptions of the loads and generators by nonlinear state space models and network connections by a set of algebraic equations. Combining them leads to a general nonlinear state space model for the entire microgrid system. Voltage stability and notions of stability margins are investigated in this framework.

There are many potential applications of this framework in exploring management, reliability, and optimality of microgrids. For instance, distribution and load allocations of PHEV charging, battery management, load management of microgrids can all be studied within this framework. Although this paper uses resistive and constant-power loads as basic examples in explaining the key ideas, the framework is general and can be applied to loads of different types and more complicated link characterizations. These will be reported in subsequent papers. The stability and robustness notion in this paper is suitable for studying local stability (small signal stability). For transient stability of large signal ranges, Lyapunov direct methods or other nonlinear control approaches need to be employed. At present, it is not clear what function forms are potential Lyapunov candidates to study such networked dynamic systems.

REFERENCES

- [1] P.M. Anderson, A.A. Fouad, *Power System Control and Stability*, 2nd Ed., John Wiley & Sons, 2003.
- [2] A. Araposthatis, S. Sastry, P. Varaiya, Analysis of power flow equation, *Electric Power & Energy Systems*, vol. 3, no. 3, pp. 115-126, 1981.
- [3] A.R. Bergen, V. Vittal, *Power System Analysis*, 2nd Ed., Prentice-Hall, 2000.
- [4] M. H. Bollen and F. Hassan, *Integration of Distributed Generation in the Power System*, John Wiley & Sons, 2011
- [5] R. Castellanos, A. R. Messina, *Robust Stability and Performance Analysis of Large Scale Power Systems With Parametric Uncertainty: A Structured Singular Value Approach*, Nova Science, 2009.

- [6] H. K. Clark, New challenges: Voltage stability, *IEEE Power Engineering Review*, pp.33-37, 1990.
- [7] T. Van Cutsem, An approach to corrective control of voltage instability using simulation and sensitivity, *IEEE Transactions on Power Systems*, vol. 10, no. 2, pp. 616-22, May 1995.
- [8] Miodrag Djukanovic, Mustafa Khammash, and Vijay Vittal, Application of the Structured Singular Value Theory for Robust Stability and Control Analysis in Multimachine Power Systems, Part I: Framework Development and Part II: Numerical Simulation and Results, *IEEE Transactions on Power Systems*, Vol. 13, pp. 13111316, November 1998.
- [9] DOE Report: The Potential Benefits of Distributed Generation and Rate-Related Issues that May Impede Their Expansion, 2007.
- [10] Xu Fu, and Xifan Wang, Determination of load shedding to provide voltage stability, *International Journal of Electrical Power and Energy Systems*, pp. 515521, vol. 33, 2011.
- [11] M. Glavic, and T. Van Cutsem, A short survey of methods for voltage instability detection, 2011 IEEE Power and Energy Society General Meeting, Detroit, USA, 2011.
- [12] R.B.L. Guedes, F.H.J.R. Silva, L.F.C. Alberto, and N.G. Bretas, Large disturbance voltage stability assessment using extended Lyapunov function and considering voltage dependent active loads, 2005 IEEE Power Engineering Society General Meeting, pp. 1760-1767 vol. 2, 2005
- [13] Ian A. Hiskens, and David J. Hill, Energy functions, transient stability and voltage behaviour in power systems with nonlinear loads, *IEEE Transactions on Power Systems*, vol. 4, no. 4, pp. 1525-1533, Nov. 1989.
- [14] G.M. Huang and Kun Men, Fast dynamic voltage stability margin estimation by integration with intelligent load adjustments, 2005 IEEE Power Engineering Society General Meeting, pp. 1908-1915, vol. 2, 2005.
- [15] IEEE/CIGRE Joint Task Force on Stability Terms and Definitions, Definition and Classification of Power System Stability, *IEEE Trans. on Power Syst.*, vol.19, no.2, pp. 1387-1401, 2004.
- [16] P. Kessel, H. Glavitsch, Estimating the Voltage Stability of a Power System, *IEEE Trans. on Power Deliv.*, vol. PWRD-1, No. 3, 1986.
- [17] H.K. Khalil, *Nonlinear Systems*, 2nd Ed., Prentice-Hall, 1996.
- [18] Davood Khani, Ahmad Sadeghi Yazdankhah, and Hossein Madadi Kojabadi, Impacts of distributed generations on power system transient and voltage stability, *International Journal of Electrical Power and Energy Systems*, pp. 488500, vol. 43, 2012.
- [19] P. Kundur, *Power System Stability and Control*, EPRI Power System Engineering Series, McGraw-Hill, 1993.
- [20] B.H. Lee, and K.Y. Lee, A study on voltage collapse mechanism in electric power systems, *IEEE Transactions on Power Systems*, vol. 6, no. 3, pp. 966-74, Aug. 1991.
- [21] M.A. Pai, R.K. Ranjan, P.W. Sauer, Robust stability in power systems with nonlinear loads using generalized Kharitonov's theorem, *International Journal of Electrical Power and Energy Systems*, 1994.
- [22] B. Pal and B. Chaudhuri, *Robust Control in Power Systems*, 2005, Springer, ISBN 978-0-387-25949-9
- [23] Y. Tamura, H. Mori and S. Lwanoto, Relationship between voltage instability and multiple load flow solutions in electrical system, *IEEE Transactions on Power Apparatus and Systems*, vol. PAS-102, no. 5, pp 115-1125, 1983.
- [24] A. Tamersi, G. Radman, and M. Aghazadeh, Enhancement of micro-grid dynamic voltage stability using microgrid Voltage Stabilizer, *IEEE SoutheastCon 2011. Building Global Engineers*, pp. 368-373, 2011
- [25] C. W. Taylor, *Power System Voltage Stability*, EPRI Power System Engineering Series, McGraw-Hill, 1993.
- [26] Nayeem Rahmat Ullah, Torbjørn Thiringer, and Daniel Karlsson, Voltage and Transient Stability Support by Wind Farms Complying With the E.ON Netz Grid Code, *IEEE Transactions on Power Systems*, pp. 1647-1656, vol. 22, no. 4, Nov. 2007.
- [27] B. Venkatesh, R. Ranjan, and H. B. Gooi, Optimal reconfiguration of radial distribution systems to maximize loadability, *IEEE Trans. on Power Syst.*, vol. 19, no. 1, pp. 260266, 2004.
- [28] K. Vu, M.M. Begovic, D. Novosel, and M.M. Saha, Use of local measurements to estimate voltage-stability margin, *IEEE Trans. on Power Syst.*, vol. 14, no.3, pp.10291035, 1999.