

# Synthesis of heat exchanger network with complex phase transition based on pinch technology and carbon tax

Dinghao Li\*, Yang Li\*, Xin Zheng\*, Jingde Wang\*,<sup>1</sup>, Wei Sun\*<sup>1</sup>

\* College of Chemical Engineering, Beijing University of Chemical Technology, 100029, Beijing, China (Tel: 010-64445826; e-mail: sunwei@mail.buct.edu.cn).

---

**Abstract:** The aim of this paper is to integrate carbon emissions into the synthesis of heat exchanger network for an industrial process with a four-stage pyrolysis gas compression cycle and depropanizers. Problem table is used to determine the pinch point for the design of heat exchanger network. Due to the complex phase transition of the mixture in the system, the phase transition is considered as a pseudo-stream with constant heat capacity flow rate according to its thermal load and material characteristics within several individual temperature intervals. The contribution of carbon tax is also introduced to the total annual cost to determine the suitable minimum approach temperature ( $\Delta T_{min}$ ). Compared with traditional pinch point method,  $\Delta T_{min}$  is determined as 8°C instead of 9°C due to the consideration of carbon emission. The pinch point is obtained at 80.15°C for hot streams and 72.15°C for cold streams, under which the minimum hot and cold utilities required by the heat exchanger network are 28046.89 kW and 69324.05kW respectively. The total annual cost is saved by 4,446,559 USD·a<sup>-1</sup> and the carbon emission is reduced by 96689.31t/a. Results indicate that the consideration of carbon emissions based on carbon tax is helpful to obtain a better heat exchanger network in terms of total annual cost and energy efficiency on the way to carbon neutrality.

**Keywords:** heat exchanger network; pyrolysis process; a pseudo-stream for phase transition; pinch point; carbon neutrality;

---

## 1. INTRODUCTION

Climate change has attracted tremendous attention worldwide. The reduction of carbon emission becomes a mission to every individual and enterprise. Even though more popular research topic under this category is carbon capture and storage/usage, the renovation in existing facility is still the fundamental solution, either through process improvement or cutting the demand of utility can minimize carbon emission from the very beginning (Sreepathi and Rangaiah, 2014). The latter is usually achieved by retrofitting heat exchanger network (Yu, 2017).

The mathematical planning method dominates in literature, but it is limited in application due to the difficulty of solving and the lack of clear physical meaning (Lu et al., 2021). In 1970s, pinch point technology with fast computation and explicit physical explanation was proposed and widely applied (Linnhoff and Hindmarsh, 1983), by which heat exchanger network is analysed and designed based on thermodynamic theory (Zhao, Sun and Luo, 2012), with the aim of recovering heat to the maximum extent and reducing the use of utilities (Ebrahim and Kawari, 2000; Yao Jing et al., 2010).

With the ever-increasing concern about the environmental

impact caused by greenhouse gases, especially CO<sub>2</sub> emissions, carbon emissions are gradually introduced into the synthesis of heat exchanger networks. Mahmoud et al. presented an integration method to consider fuel switching and heat exchanger network together to reduce CO<sub>2</sub> emissions (Mahmoud et al., 2009). However, economic factor is ignored in above study. In order to consider both the economic and environmental factor, several heat exchanger network synthesis methods based on multi-objective optimization (MOO) have been proposed. López-Maldonado et al. proposed a MOO model based on mixed integer nonlinear programming to optimize the total annual cost objective and environmental impact objective simultaneously (López-Maldonado et al., 2011). In their study, many environmental factors were taken account by a combined indicator and carbon emission wasn't specifically emphasized. Therefore, accumulated carbon emissions are further introduced into the heat exchanger network synthesis by researchers (Gharaie et al., 2013, Kang et al., 2015). Carbon tax, as a tax policy aiming to quantify the cost of carbon emissions for enterprise, have been carried out in some countries to encourage investment in emission reduction technologies and application of renewable energy (Ayodele et al, 2021). To reduce total annual costs for enterprise, it is necessary to integrate carbon tax into the utility cost function of heat exchanger network synthesis.

---

<sup>1</sup> Corresponding author

At present, most study on heat exchanger network is assumed no phase transition in streams. However, streams may undergo phase transition during heat exchange in real process and the latent heat of phase transition has a great influence on the whole heat exchange network structure, which requires a proper consideration.

In this paper, considering the complex phase transition stream and the cost of carbon emission, the synthesis of heat exchange network in gas separation compression cycle after cracker in naphtha cracking process is carried out based on the pinch point technology. The result of optimized heat exchange network is discussed to illustrate the effect of energy saving and emission reduction.

## 2. HEAT EXCHANGER NETWORK SYNTHESIS ANALYSIS

In this work, the synthesis of heat exchange network is performed on a naphtha cracking unit in China. The annual processing capacity and operation time of the unit is 1.6 million tons and 8000 hours, respectively. Eight mixture streams from cracking gas compression cycle and depropanizer towers are selected due to their large energy demand and room for energy optimization. Specifically, four hot and two cold streams of among them undergo phase transition during heat exchange according to the requirement of process in which both latent heat and sensible heat need to be properly considered. There is no phase transition in remaining 2 cold streams. The detailed procedure of heat exchanger network synthesis is presented as follows.

### 2.1 Stream information in the heat exchanger network

The phase transition in mixture stream is considered in certain streams, which make temperature variate during phase changing process. To better describe the process in heat exchanger network, a pseudo-stream is defined, which can be characterized by a constant heat capacity with component transferred from one phase to another in one stream, usually between gas and liquid phases. Specifically, a stream can be divided into at most three sub-streams according to the enthalpy change of the stream itself, usually related to the lowest bubble point and highest dew point. (Yao et al., 2000).

According to the design, six streams contain partial phase transition, and are considered in different temperature intervals according to their phase changing characters. Taking H1 stream as an example, it is vapor-liquid coexistence phase after heat transfer, whose temperature range between the bubble point and the dew point is not less than 22°C. According to the property of different components in the mixture stream and enthalpy changes, its phase transition is divided into heavy hydrocarbon phase transition part and water phase transition part. Similarly, the rest streams with phase transition are divided in the same way. Besides, the heat capacity flow rates  $C_p$  of the two cold streams without phase transition are treated approximately as constants. Temperature intervals and corresponding heat capacity flow rates for all stream are shown in Table 1.

**Table 1 Information table for all streams**

Stream Label	Inlet temperature	Output temperature	Heat capacity flow rate
	/°C	/°C	
H1	89.8	60	349.35
	60	53.7	503.09
	53.7	38	1182.66
H2	88.2	53.9	332.99
	53.9	50.9	367.88
	50.9	38	730.6
H3	88.4	57.2	331.81
	57.2	53	353.36
	53	38	575.86
H4	88.3	60.7	335.95
	60.7	57.4	345.02
	57.4	38	521.27
C1	37.9	50	316.08
C2	71.9	72.4	581.9
	72.4	78.3	1656.24
C3	42.8	120.1	357.32
C4	77.5	78.2	438.82
	78.2	80.8	4622.01

### 2.2 Problem table method

As the heat exchange network consists of multiple streams and phase transition, the pinch point is hard to specified by horizontally moving temperature-enthalpy curve in enthalpy diagram under different  $\Delta T_{min}$ . Problem table method is therefore adopted to obtain the pinch points, while the amount of cold and hot utilities can be calculated more accurately. Before conducting the calculation in the problem table,  $\Delta T_{min}$  need to be specified first.

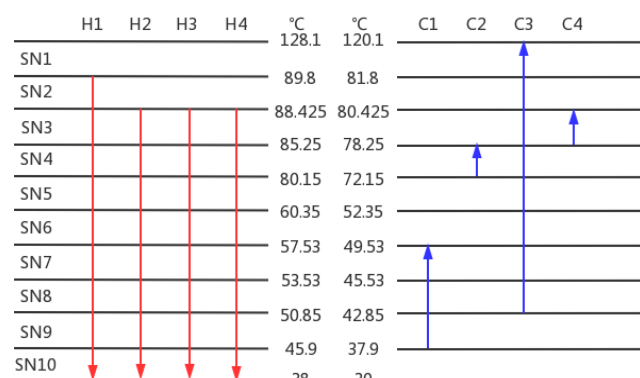

Fig. 1. Temperature interval chart.

Both thermodynamic and engineering feasibility need to be considered when  $\Delta T_{min}$  is determined. Different choices of  $\Delta T_{min}$  will affect both utility cost and equipment investment. According to process knowledge and stream characteristics,

the  $\Delta T_{\min}$  of the heat exchanger network is calculated from 5 to 14 °C for later total annual cost estimation. As an example, the calculation of the problem table method with  $\Delta T_{\min} = 8$  °C is illustrated as follows. The initial and final temperatures of the hot stream are subtracted by 8 °C and sorted together with the initial and final temperatures of the cold stream to obtain the endpoint temperature values of the temperature interval. After sorting, there are some extremely similar temperatures in the heat exchange network which can lead to the temperature interval is too small. In order to simplify the calculation and improve the computational efficiency, all the temperature values within the 1°C interval are reordered to obtain the new temperature interval by average of the temperature as Fig. 1.

Since the heat load of stream may be affected by simplified calculation of temperature intervals, heat load of streams with an error of more than 5 % are corrected in the heat demand and further obtain the problem table as shown in Table 2.

**Table 2 Problem table**

SN	$D_k$ /kW	Utilities input to the process			
		Without		With	
		$I_k/KW$	$O_k/KW$	$I_k/KW$	$O_k/KW$
SN1	13685.36	0	-13685.36	28046.89	14361.54
SN2	10.92	-13685.36	-13696.27	14361.54	14350.62
SN3	10303.51	-13696.27	-23999.79	14350.62	4047.11
SN4	4047.11	-23999.79	-28046.89	4047.16	0
SN5	-19657.04	-28046.89	-8389.85	0	19657.04
SN6	-3258.76	-8389.85	-5131.08	19657.04	22915.81
SN7	-4116.21	-5131.08	-1014.87	22915.81	27032.02
SN8	-5173.11	-1014.87	4158.24	27032.02	32205.13
SN9	-13336.83	4158.24	17495.07	32205.13	45541.97
SN10	-23782.08	17495.07	41277.15	45541.97	69324.05

**Table 3 Cost saving achieved by heat integration under different  $\Delta T_{\min}$**

$\Delta T_{\min}$ /°C	Pinch /°C	Hot utility		Cold utility		Energy saving potential	
		/kW	/kW	/kW	/kW	Hot utility	Cold utility
5	74.65	23943.02	65228.43	55.52%	31.41%		
6	75.15	25293.12	66578.53	53.02%	29.99%		
7	75.65	26676.94	67908.86	50.44%	28.59%		
8	76.15	28046.89	69324.05	47.90%	27.10%		
9	76.65	29343.42	70575.12	45.49%	25.79%		
10	77.15	30493.88	71977.65	43.35%	24.31%		
11	77.65	32138.89	73347.56	40.30%	22.87%		
12	78.15	33393.71	74679.24	37.97%	21.47%		
13	78.65	34743.82	75975.6	35.46%	20.11%		
14	79.15	36093.92	77527.15	32.95%	18.47%		

In Table 2, SN represents each temperature interval,  $D_k$ ,  $I_k$ , and  $O_k$  are the heat demand, the heat input, and the heat output in temperature interval  $k$  respectively. After the

calculation of enthalpy balance in each temperature interval, the pinch point temperature is obtained as 80.15 °C and 72.15 °C for hot streams and cold streams respectively, the minimum hot utility demand is 28046.89 KW and the minimum cold utility demand is 69324.04 kW. The actual hot and cold utilities of the original heat exchange system are 53,832.83 kW and 95,095.91 kW respectively. It can be calculated easily that the energy saving potential reaches 47.90 % and 27.10 % respectively. Consist with the above calculation, the results with  $\Delta T_{\min} \in [5, \dots, 14]$  are obtain as shown in Table 3.

### 2.3 Selection of $\Delta T_{\min}$ under the conventional pinch point method

The optimal  $\Delta T_{\min}$  of heat exchange network is obtained by the evaluation based on total cost, and more detail information is shown below.

#### 2.3.1 Capital cost

The capital cost (CC) of the heat exchanger network, including the manufacturing expenses of heat exchanger area and the fixed charge of heat exchanger, is calculated by equation (1).

$$CC = CA \times A + Cf \times N \quad (1)$$

where  $CA$ ,  $A$ ,  $Cf$ ,  $N$  represent unit area cost, heat exchanger area, fixed costs of a single heat exchanger, and number of heat exchangers respectively. The number of heat exchanger is ignored for rapid assessment of the investment costs. The manufacturing costs of heat exchanger area is assumed to account for 94% of the investment costs, then the equation (1) can be transformed into equation (2):

$$CC = CA \times A / 0.94 \quad (2)$$

And the area of heat exchange is calculated as follows:

$$A_{HC} = Q_{HC} / (K_{HC} \times LMTD_{HC}) \quad (3)$$

$$A_{HU} = Q_{HU} / (K_{HU} \times LMTD_{HU}) \quad (4)$$

$$A_{CU} = Q_{CU} / (K_{CU} \times LMTD_{CU}) \quad (5)$$

where  $Q$  denotes load of heat exchanger,  $K$  is the heat transfer coefficient,  $LMTD$  is the logarithmic mean temperature difference, and the subscripts  $HC$ ,  $HU$ ,  $CU$  indicate process stream, hot utilities, and cold utilities respectively.

#### 2.3.2 Utility cost

The objective function of utility cost ( $UC$ ) including consumption costs of hot utility and cold utility is shown in equation (6), where  $C_{CU}$  and  $C_{HU}$  are the unit operation cost of cold and hot utilities,  $q_{CU_i}$  and  $q_{HU_j}$  represent cold utility load on the  $i^{th}$  hot stream and hot utility load on the  $j^{th}$  cold stream respectively.

$$UC = C_{CU} \times \sum_{i=1}^i q_{CU_i} + C_{HU} \times \sum_{j=1}^j q_{HU_j} \quad (6)$$

### 2.3.3 Total annual cost of heat exchange network

The total annual cost (TAC) generally consists of two parts: investment cost and utility cost. In order to reduce the energy consumption of utility, heat exchanger network needs to be improved to recover the effective energy between the streams as economically as possible by increasing the investment in heat exchange equipment. The total annual cost of the heat exchanger network is determined by a trade-off between the operation cost and investment cost which can be calculated by equation (7):

$$TAC = CC/n + UC \quad (7)$$

where  $n$  is the operation life of the equipment, and the cost parameters related to the heat exchange network are shown in Table 4(Jiang et al., 2020).

The calculated results of total annual costs with different  $\Delta T_{\min}$  are shown in Table 5.

**Table 4 Cost-related parameters**

Parameters	value
Heat exchanger unit area cost CA/USD	622.6
Unit hot utility cost $C_{HU}/\text{USD}\cdot\text{kW}^{-1}\cdot\text{a}^{-1}$	140
Unit cold utility cost $C_{CU}/\text{USD}\cdot\text{kW}^{-1}\cdot\text{a}^{-1}$	10
Equipment operation life/a	5
Heat transfer coefficient between process streams $K_{HC}/\text{W}\cdot\text{m}^{-2}\cdot\text{K}^{-1}$	250
Heat transfer coefficient between hot utilities and streams $K_{HU}/\text{W}\cdot\text{m}^{-2}\cdot\text{K}^{-1}$	540
Heat transfer coefficient between cold utilities and streams $K_{CU}/\text{W}\cdot\text{m}^{-2}\cdot\text{K}^{-1}$	400

**Table 5 Costs for different  $\Delta T_{\min}$  choices**

Minimum approach temperature /°C	Investment costs /USD·a <sup>-1</sup>	Utilities Costs /USD·a <sup>-1</sup>	Total annual cost /USD·a <sup>-1</sup>
5	4,550,044	4,004,306	8,554,350
6	3,850,361	4,206,821	8,057,183
7	3,326,286	4,481,768	7,808,054
8	2,927,676	4,758,453	7,686,129
9	2,618,843	5,025,554	7,644,397
10	2,371,097	5,276,830	7,647,927
11	2,156,294	5,599,658	7,755,953
12	1,984,239	5,869,987	7,854,226
13	1,836,240	6,155,719	7,991,960
14	1,706,978	6,448,637	8,155,615

As shown in Fig. 2., the lowest total annual cost obtained with  $\Delta T_{\min} = 9^\circ\text{C}$  by applying traditional pinch technology is 7,644,397 USD·a<sup>-1</sup>. Compared with the total annual cost of the original heat exchange network, the saving potential of optimized heat exchange system is 25.18%.

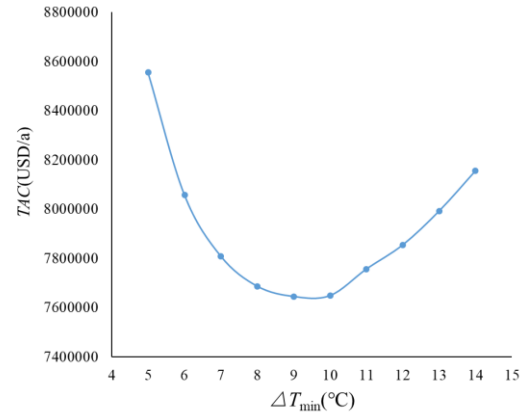

Fig. 2. Relationship between total annual cost with the traditional pinch method and  $\Delta T_{\min}$

### 2.4 Selection of $\Delta T_{\min}$ with the consideration of carbon emission

In recent years, the world has continued to promote environmental pollution control and ecological protection, actively promotes economic transformation and upgrading, reduces carbon emissions, and achieves green development. Energy loss is closely related to carbon emissions, and the increasing amount of heat recovered from the heat exchange network will reduce the amount of additional hot utilities required, which will result in lower fuel consumption and lower carbon emissions. To reduce energy loss and carbon emissions simultaneously, carbon emission cost based on carbon tax is introduced to the total annual cost objective function of the heat exchange network (Li, 2010). The total annual cost of the heat exchanger network with additional carbon emission by applying the traditional pinch technology is shown in equation (8):

$$TAC = CC/n + UC + C_{tax} \quad (8)$$

where  $C_{tax}$  is the carbon emission cost, and it is calculated by multiplying the  $E$  (annual carbon emissions) by the carbon tax price as follows.

$$E = \frac{Q_{Fuel}}{NHV} \times \frac{C\%}{100} \times a \times 3600 \times t \quad (9)$$

where  $Q_{fuel}$  is the heat load supplied to the system with fuel,  $a$  is the ratio of the molar masses of  $\text{CO}_2$  and  $\text{C}$ , and  $NHV$  is the net fuel combustion value,  $C\%$  is the mass percentage of carbon contained in the fuel, and  $t$  is the operation time of plant. The calculation of  $Q_{fuel}$  is simplified as follows (Li, 2010).

$$Q_{Fuel} = \frac{Q_{Proc}}{\eta_{Boiler}} \quad (10)$$

where  $Q_{Proc}$  is the heat load required for the production, and  $\eta_{Boiler}$  is the boiler efficiency.

**Table 6 Cost parameters for carbon emission**

Parameters	Value
NHV/kJ·kg <sup>-1</sup>	30,000
C%	74.5
$\eta_{Boiler}/\%$	70
Carbon tax/ USD·t <sup>-1</sup>	20

Due to the complexity of calculating carbon emissions from other associated plants, only the carbon emissions from the fuel consumed by the heat exchange network hot utility are taken into account and the related cost parameters are shown in Table 6 (Li, 2010).

The calculated results of cost with the consideration of carbon emission are shown in Table 7. The annual carbon emission of the initial heat exchange network is 201856.5 tons, and the total annual cost is 14,254,032 USD·a<sup>-1</sup>. Fig. 3 shows the total annual cost graph obtained by pinch point method after introducing the carbon emission target, and its optimal  $\Delta T_{min}$  is changed from 9 °C to 8 °C.

**Table 7 Cost with the consideration of carbon emission**

$\Delta T_{min}$	Carbon emission	Carbon emission cost	Cost with the consideration of carbon Emission
/°C	/ton·a <sup>-1</sup>	/USD·a <sup>-1</sup>	/USD·a <sup>-1</sup>
5	89778.93	1,795,578	10,349,929
6	94841.39	1,896,827	9,954,010
7	100030.27	2,000,605	9,808,660
8	105167.19	2,103,343	9,789,473
9	110028.76	2,200,575	9,844,972
10	114342.63	2,286,852	9,934,780
11	120510.93	2,410,218	10,166,171
12	125216.12	2,504,322	10,358,549
13	130278.6	2,605,571	10,597,532
14	135341.05	2,706,820	10,862,436

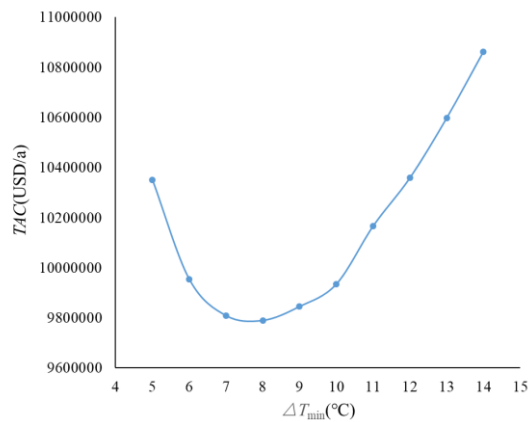

Fig. 3. Relationship between total annual cost with the carbon emission and  $\Delta T_{min}$

The annual carbon emission of the heat exchanger network obtained after introducing the carbon emission target is 105167.19 tons, which is 4.42% lower than the heat exchanger network under the optimal  $\Delta T_{min}$  obtained by the traditional pinch point method. And the corresponding annual carbon dioxide emission can be reduced by 4861.56 tons. Meanwhile, the total annual cost is 9,789,473 USD·a<sup>-1</sup>, which is 0.56% lower. In general, with the consideration of carbon emission target, the utility consumption, carbon emission and total annual cost are all reduced compared with the heat exchanger network obtained by the traditional pinch point method, and the corresponding increase of heat exchanger area is within a reasonable range.

Finally, the optimal  $\Delta T_{min}$  of heat exchanger network is selected as 8 °C, which can reduce the annual CO<sub>2</sub> emission by 47.9% to 96,689.31 tons compared with the initial heat exchange network, and the total annual cost is reduced by 31.32%.

### 2.5 Designing energy-optimal heat exchange network

The average pinch point temperature is determined by the problem table method as 76.15 °C (80.15 °C for hot streams and 72.15 °C for cold streams). On the basis of principle of energy optimal design of heat exchange network and feasibility principle, the comprehensive problem of heat exchange network is decomposed into two sub-problems of cold end and hot end at the pinch point. The “tick-off” method is employed for the matching among streams with the minimum number of heat exchange units to obtain the energy-optimal heat exchange network of the process as shown in Fig. 4. (Zhang et al., 2011).

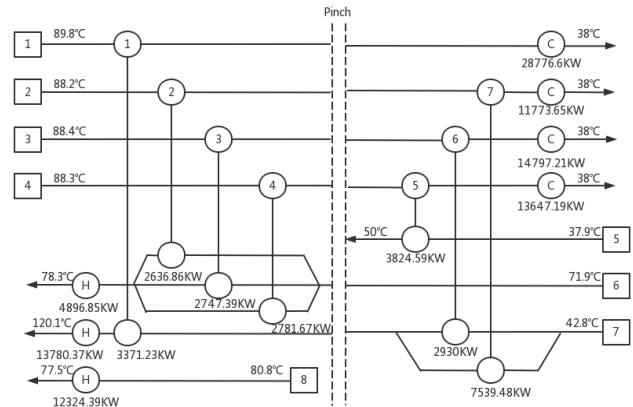

Fig. 4. Synthesis of heat exchanger network in terms of the consideration of carbon emission with utility cost

The topology of the energy-optimal heat exchange network obtained by the traditional pinch method is the same as that by the consideration of carbon emission, but the load distribution for energy recovery is quite different. For comparison, less utility is cost by the heat exchange network with carbon emissions. The amount of hot and cold utilities required for the entire heat exchange network is 28046.89

kW and 69324.05 kW respectively, and the amount of heat utilization is 25778.90 kW.

### 3. CONCLUSIONS

Aiming to an ethylene plant cracking gas separation unit, carbon emission target is introduced to the synthesis of heat exchange network with complex phase transition process, and the total annual cost under the carbon emission target is evaluated. Compared with the conventional pinch point method, the optimized heat exchange network is more energy-efficient, with lower carbon emissions and less annual cost. Specifically, it adds 6 heat exchangers compared with the initial network, and the heat recovery volume increases to 25778.90kW, which significantly improves the energy utilization rate. The annual carbon emission is reduced by 96,689.31 ton, and the total annual cost is reduced by 4,464,559 USD·a<sup>-1</sup>.

### REFERENCES

- Ayodele, O. F., Ayodele, B. V., Mustapa, S. I., & Fernando, Y. (2021). Effect of activation function in modeling the nexus between carbon tax, CO<sub>2</sub> emissions, and gas-fired power plant parameters. *Energy Conversion and Management*: X, 12, 100111.
- Cui Y. H. (2012). Optimal design of heat-exchanger networks based on state space. (Masteral dissertation, Dalian University of Technology).
- Ebrahim, M. (2000). Pinch technology: an efficient tool for chemical-plant energy and capital-cost saving. *Applied Energy*, 65(1-4), 45-49.
- Gharaie, M., Zhang, N., Jobson, M., Smith, R., & Panjeshahi, M. H. (2013). Simultaneous optimization of CO<sub>2</sub> emissions reduction strategies for effective carbon control in the process industries. *Chemical Engineering Research and Design*, 91(8), 1483-1498.
- Jiang, N., Fan, W., Xie, X. D., Guo, F. Y., Li, E. T., & Zhao, S. C. (2020). Comparative study of NSGA- II and NSGA- III on multi-objective optimization of heat exchanger network. *Chemical Industry & Engineering Progress* (07), 2534-2547.
- Kang, L., Liu, Y., & Liang, X. (2015). Multi-objective optimization of heat exchanger networks based on analysis of minimum temperature difference and accumulated CO<sub>2</sub> emissions. *Applied Thermal Engineering*, 87, 736-748.
- Li L. (2010). Research on Method of heat exchanger network synthesis based on flow exergy dissipation and heat transfer exergy dissipation. (Masteral dissertation, Zhejiang University of Technology).
- Linnhoff, B., & Hindmarsh, E. (1983). The pinch design method for heat exchanger networks. *Chemical Engineering Science*, 38(5), 745-763.
- López-Maldonado, L. A., Ponce-Ortega, J. M., & Segovia-Hernández, J. G. (2011). Multiobjective synthesis of heat exchanger networks minimizing the total annual cost and the environmental impact. *Applied Thermal Engineering*, 31(6-7), 1099-1113.
- Lu, Z. L., Qin, K., Wu, H., He, Y., & Cao, W. L. (2021). Research progress on multi-objective optimization of heat exchanger networks. *Energy Conservation* (02), 75-79.
- Mahmoud, A., Shuhaimi, M., & Samed, M. A. (2009). A combined process integration and fuel switching strategy for emissions reduction in chemical process plants. *Energy*, 34(2), 190-195.
- Sreepathi, B. K., & Rangaiah, G. P. (2014). Review of heat exchanger network retrofitting methodologies and their applications. *Industrial & engineering chemistry research*, 53(28), 11205-11220.
- Shen, C. C., Zhao, D. F., Xue, J. L., & Li, S. (2012). Application of pinch point technology in recovery of low temperature heat in a crude distillation unit. *Petroleum Refinery Engineering*, 07.
- Yu, H. S. (2017). Heat exchanger networks retrofit based on modified superstructure. (Masteral dissertation, Zhejiang University of Technology).
- Yao, J., Wang, Y., & Kuang, G. Z. (2010). Energy Analysis of the Natural Gas Refining Equipment With Pinch Technology. *Liaoning Chemical Industry*, 3.
- Yao, K. J., Zhang, S. H., & Zhu, L. Y. (2000). Application of Pinch Technology in Refining System. *PETROCHEMICAL TECHNOLOGY*, 29(4), 276-278.
- Zhang, W. D., Sun, W., & Liu J. T. (2011). Analysis and Synthesis for Chemical Engineering Process. 197-212. Chemical Industry Press, Bei Jing.
- Zhao, Y., Sun, L., & Luo, X. L. (2012). Research advances in pinch technology and the synthesis of multipass heat exchanger networks. *Chemical Industry and Engineering Progress*, 8.