

# Identifying interspecies interactions within a model methanotroph-photoautotroph coculture using semi-structured and structured modeling

Kiumars Badr\* Q. Peter He\* Jin Wang\*\*

\*Auburn University, Auburn, AL 36830 USA

(e-mail: [kzb0054@auburn.edu](mailto:kzb0054@auburn.edu); [qhe@auburn.edu](mailto:qhe@auburn.edu); [wang@auburn.edu](mailto:wang@auburn.edu)).

---

**Abstract:** Methanotroph-photoautotroph (M-P) coculture has been demonstrated to be a highly promising biotechnology platform for biogas conversion. The metabolic coupling of methane oxidation and oxygenic photosynthesis within the coculture offers many benefits for the design of robust biotechnologies for biogas conversion. In addition, it has been postulated that the potential emergent interspecies interactions within the coculture could further enhance the growth of the coculture and play a pivotal role in determining the composition and function of the coculture. However, no knowledge on these emergent metabolic interactions is currently available. This is mainly due to the inherent complexity of the M-P coculture, and the lack of experimental tools to characterize the coculture. In this work, enabled by a novel experimental-computational protocol we developed recently to accurately characterize the M-P coculture in real time, we aim to elucidate the potential emergent metabolic interactions within a model coculture (*Methylobacterium buryatense* – *Arthrospira platensis*). Using designed experiments, we were able to confirm the existence of other interspecies metabolic interactions, in addition to the exchange of the *in situ* produced O<sub>2</sub>/CO<sub>2</sub> within the model M-P coculture. Moreover, through semi-structured kinetic modeling, we were able to quantify the effect of these additional interspecies interactions, albeit unknown, on the growth of the model coculture. Finally, we developed the very first genome-scale model for the M-P coculture, which consistently predicts the top 8 metabolite being exchanged between the methanotroph and photoautotroph within the coculture, which contribute to the enhanced growth observed in the experiment.

**Keywords:** Methanotroph-photoautotroph coculture; interspecies metabolic interactions, unstructured kinetic modeling, genome-scale metabolic model.

---

## 1. INTRODUCTION

Biogas (50%~70% CH<sub>4</sub>, 30%~40% CO<sub>2</sub>) produced from anaerobic digestion (AD) of organic waste streams has immense potential as a renewable feedstock to produce high-density fuels and value-added products. CO<sub>2</sub> and CH<sub>4</sub> are the two leading greenhouse gases (GHGs) that cause climate change with many detrimental effects to the earth's ecosystem, and AD enables the containment of biogas produced from waste degradation that otherwise would be released into atmosphere. Currently, combined heat and power (CHP) production is the dominant route for the utilization of AD-generated biogas. However, the presence of contaminants such as H<sub>2</sub>S, NH<sub>3</sub>, and volatile organic carbon compounds requires significant capital expenditure (CapEx) (for corrosion resistant generator) and operation expenses (OpEx) (to maintain a suite of scrubbers to remove the contaminants) for CHP production. The high CapEx and OpEx, together with the low value of the products (e.g., heat and electricity), result in unfavorable return-on-investment (ROI) for biogas production and CHP. Therefore, despite the fact that AD is a mature technology that can offer significant environmental and social benefits, as well as the enormous energy potential, the deployment of AD is still quite limited. For example, only 288 farms utilize AD for manure management (EPA, 2021), which represents 0.064% of roughly 450,000 animal farms and 3% of all concentrated animal feeding operations (CAFOs) in the US. To tap into the immense potential of biogas production from waste streams,

effective biotechnologies are urgently needed that can operate at ambient temperature and pressure, without requiring biogas cleaning/upgrading, and are economically viable at small to mid-scale.

### 1.1 Methanotroph-photoautotroph coculture holds great potential for biogas conversion

Natural microbial communities have developed a highly effective solution to recover energy and recycle carbon from naturally produced biogas through metabolic coupling of methane oxidation to oxygenic photosynthesis (Kip et al., 2010; Milucka et al., 2015; Raghoebarsing et al., 2005). Using the principles that drive the natural consortia, we have assembled and investigated several different methanotroph-photoautotroph (M-P) cocultures that exhibit stable growth under varying substrate delivery and illumination regimes (Badr et al., 2022; Roberts et al., 2020). Fig. 1. depicts the potential interactions within the M-P coculture. These interactions include the known cooperative interactions (or mutualism) between the two partners, i.e., the exchange of *in situ* produced O<sub>2</sub> and CO<sub>2</sub> (the methanotroph consumes the O<sub>2</sub> produced by the photoautotroph through photosynthesis, while the photoautotroph consumes the CO<sub>2</sub> produced by the methanotroph through methane oxidation), and additional unknown interactions.

From an engineering perspective, coupling methane oxidation with oxygenic photosynthesis offers several advantages for the

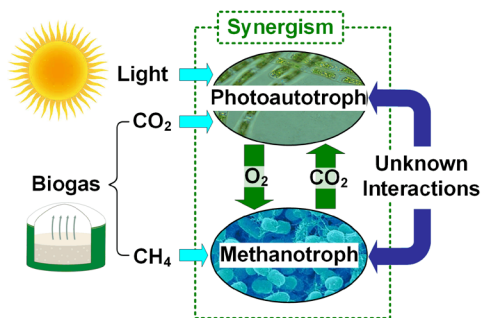

Figure 1. Potential interactions within a methanotroph-photoautotroph coculture.

design of robust microbial catalysts for biogas conversion. The mutualistic interaction can dramatically reduce the mass transfer resistance of the two gas substrates; the *in situ*  $O_2$  consumption removes inhibition on photoautotroph growth and eliminates risk of explosion; the interdependent yet compartmentalized configuration of the coculture offers flexibility and more options for metabolic engineering. Finally, there may be other emergent interactions such as exchange of different metabolites that are currently unknown. These emergent interspecies metabolic interactions may play pivotal roles in determining the composition and function of the coculture but are poorly understood due to the inherent complexity of the M-P coculture (such as the cross-feeding mechanism and other unknown interactions) and the lack of effective experimental tools to accurately characterize the coculture in real-time.

### 1.2 Unstructured and structured modeling

Mathematical modeling has been demonstrated as a highly effective tool to elucidate the complex cellular metabolism and potential interspecies interactions (Palsson, 2015). Generally speaking, existing modeling approaches for microbial systems can be divided into two groups: unstructured and structured models. The unstructured models do not include cellular metabolic details (i.e., intracellular reaction pathways) and rely on empirical relationships to capture the dynamics of substrate consumption, product excretion and biomass growth. Monod or Monod-like kinetics models are the most commonly utilized unstructured models, which can provide an overall picture on the growth and product excretion pattern of a microbial system over time under given growth conditions. On the other hand, structured models contain cellular metabolic details, and the ones that cover genome-scale details are termed genome-scale metabolic models (GEMs). In the past few decades, GEM has drawn significant research interest and saw many successful applications in omics data integration, biological discovery and mutant development. Given the limited knowledge available on the kinetics of intracellular reactions, GEMs usually assume that the cellular metabolism is always in a pseudo-steady-state, as cellular metabolism is much faster than other cellular process such as gene expression. This assumption eliminates the needs of kinetic parameters for all the intracellular reactions, and the GEM relies on the stoichiometric matrix of the metabolic network to compute the genome-wide metabolic flux distribution under given conditions.

For the M-P coculture, despite its great potential for biogas conversion, most of the existing results are limited to qualitative proof-of-concept experiments. So far there has not been any quantitative modeling on the growth kinetics of the M-P cocultures except our recent work (Badr et al., 2022). Besides the complex and unknown metabolic interactions within the coculture, lack of real-time and accurate characterization of M-P cocultures is a key reason. To address this limitation, we recently developed a novel experimental-computational (E-C) protocol to accurately characterize the M-P coculture in real-time using commonly available measurements (Badr et al., 2021). The E-C protocol has been demonstrated to provide accurate measurements of individual biomass growth rates, the individual substrate uptake rates and product excretion rates for each organism. Enabled by the E-C protocol for real-time characterization of the M-P coculture, we developed the very first kinetic model that can accurately predict the coculture growth under a wide range of conditions (Badr et al., 2022). We term the kinetic model semi-structured, as it explicitly captures the exchange of  $CO_2$  and  $O_2$  produced *in situ*.

In this work, we developed the very first GEM for the model M-P coculture using Microbiome Toolbox (Baldini et al., 2019). Utilizing both the semi-structured kinetic model and the fully-structured GEM, and combined with experimental design, we were able to identify the emergent interspecies metabolic interactions within a model M-P coculture (*Methylobacterium buryatense* – *Arthrosipira platensis*). Using designed experiments, we first confirmed that there exist other emergent metabolic interactions in the coculture, in addition to the exchange of the *in situ* produced  $O_2/CO_2$ . Next, using the semi-structured kinetic model for the coculture, we quantified the effects of these emergent interactions, albeit unknown, on the growth of both species in the coculture. Finally, with the very first GEM for the M-P coculture, we were able to predict the metabolites that are exchanged during the coculture growth. Our extensive simulations under various *in silico* setups using the coculture GEM consistently predicted the same top 8 exchange metabolites contributing to enhanced growth rate of the cocultured partners.

## 2. VALIDATING THE EXISTENCE OF ADDITIONAL METABOLIC INTERACTIONS

It has been argued that in addition to the exchange of *in situ* produced  $O_2$  and  $CO_2$  There may exist other metabolic exchanges that enhance the growth of the M-P coculture. However, there has not been any effort either to validate the existence of these potential interactions or to quantify their effects on the coculture growth. To answer these questions, we designed a set of experiments to compare the M-P coculture with its sequential single culture, and a hypothetical case of coculture where the exchange of *in situ* produced  $O_2$  and  $CO_2$  is the only interspecies interaction.

Fig. 2 (a - c) illustrate the designed comparative experiments. Case A is the coculture of *M. buryatense* – *A. platensis* with a synthetic biogas (70%  $CH_4$  and 30%  $CO_2$ ) as feed gas; Case B is the sequential single culture of both species grown on the synthetic biogas, with the amount of  $O_2$  produced by *A. platensis* single culture injected into the single culture of *M.*

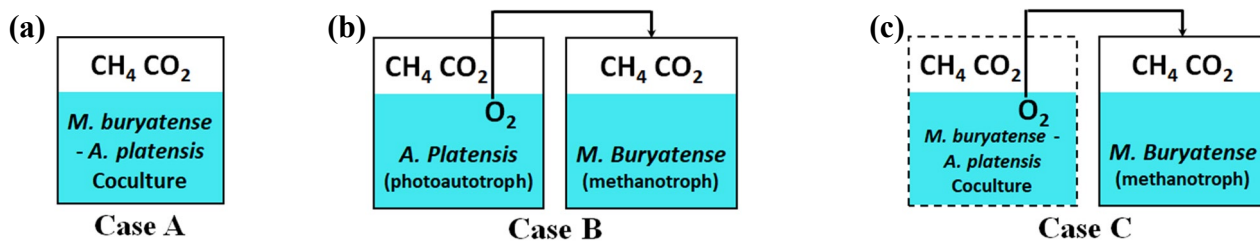

Figure 2. Illustration of the designed comparative experiments.

*buryatense* to support the methanotroph growth; Case C simulates a hypothetical case of coculture where the exchange of *in situ* produced  $\text{CO}_2$  and  $\text{O}_2$  is the only metabolic interaction within the coculture. This was achieved by injecting the amount of  $\text{O}_2$  produced by *A. platensis* in the coculture, which is larger than that produced by *A. platensis* single culture as shown in Fig. 3a, into the single culture of *M. buryatense*.

If either or both species in the coculture (Case A) show better growth than that or those in the sequential single culture (Case B), it will confirm that the coculture offers additional advantages over the sequential single culture, likely due to the exchange of *in situ* produced  $\text{CO}_2/\text{O}_2$  and other potential emergent metabolic interactions; To test whether there exist additional metabolic interactions that further enhance the coculture growth, we compare the actual coculture (Case A) where all intraspecies interactions are in place with the hypothetical coculture (Case C) where the exchange of *in situ* produced  $\text{CO}_2/\text{O}_2$  is the only interspecies interaction. If the methanotroph in Case A shows better growth than that in Case C, it will confirm the existence of other metabolic interactions, as the enhanced growth of *M. buryatense* observed in the coculture cannot be fully accounted for by the availability of  $\text{O}_2$  due to the exchange of *in situ* produced  $\text{CO}_2/\text{O}_2$  alone.

Using the novel E-C protocol we developed recently to characterize the M-P coculture (Badr et al., 2021), we were able to measure the biomass concentration of both species in the coculture, as well as the amount of  $\text{O}_2$  produced by *A. platensis* and  $\text{CO}_2$  produced by *M. buryatense* in the coculture. Fig. 3a compares the amount of  $\text{O}_2$  produced by *A. platensis* and the amount of  $\text{CO}_2$  produced by *M. buryatense* in Cases A & B, respectively. Fig. 3a showed that during the same growth period, *A. platensis* and *M. buryatense* in the coculture produced 30% more  $\text{O}_2$  and 62% more  $\text{CO}_2$  than their single

cultures, respectively. The enhanced production of  $\text{O}_2$  and  $\text{CO}_2$  in the coculture suggests the enhanced growth of both species in the coculture, compared to their single cultures. Indeed, Fig. 3b compares the biomass growth of *A. platensis* in coculture and sequential single culture, which confirms the enhanced growth of *A. platensis* in the coculture (26% increase compared to that in Case B). This is consistent with the enhanced  $\text{O}_2$  production in the coculture. Fig. 3c compares the biomass growth of *M. buryatense* in Cases A, B, and C. This shows that the methanotroph grew the fastest in the coculture, which demonstrated 57% increase over that in Case B and 28% increase over that in Case C. Fig. 3c clearly demonstrated that the growth enhancement of *M. buryatense* observed in the coculture cannot be fully explained by the supply of *in situ* produced  $\text{O}_2$  alone, which confirmed the existences of other metabolic interactions within the coculture.

### 3. QUANTIFYING THE EFFECT OF THE METABOLIC INTERACTION ON COCULTURE GROWTH

To quantitatively model the growth dynamics of the coculture, we have developed a kinetic model that accounts for the exchange of *in situ* produced  $\text{O}_2$  and  $\text{CO}_2$  (Badr et al., 2019). Recently, we expanded the model to cover the dynamic changes in both the gas and liquid phases. The expanded kinetic model consists of four components: (1) biomass growth of the photoautotroph; (2) biomass growth of the methanotroph; (3) mass balance in the liquid phase; and (4) mass balance in the gas phase. The growth of each organism in the coculture is coupled with the gas phase composition changes through the mass balances in the liquid and gas phase, and mass transfer between the gas and liquid phase. In the semi-structured kinetic modeling framework, cell growth is described using Monod equations; the substrate consumption rates and product excretion rates are determined through the yield coefficients between the corresponding substrate/product

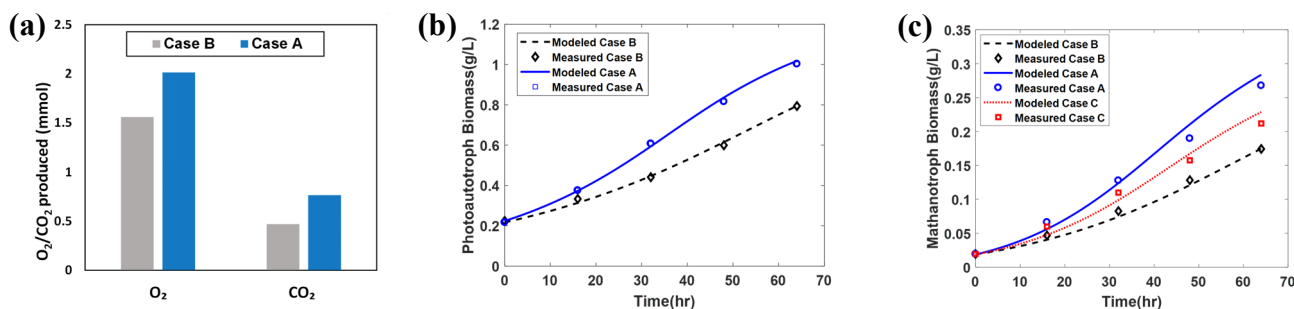

Figure 3. Comparison of (a) the amount of  $\text{O}_2$  produced by *A. platensis* and  $\text{CO}_2$  produced by *M. buryatense* in Cases A & B, (b) the individual biomass concentration in the coculture and sequential single culture for (b) *A. platensis* and (c) *M. buryatense* 5GB1.

and the biomass. The model is termed semi-structured because the exchange of *in situ* produced O<sub>2</sub> and CO<sub>2</sub> is explicitly modeled, while the other potential interspecies interactions are captured through lumped parameters, i.e.,  $\mu_{max}^i$ , maximum growth rate of each organism *i*. More details of the semi-structured model can be found in (Badr et al., 2022).

Since  $\mu_{max}^i$  captures the effect of the additional interspecies metabolic interaction other than the exchange of *in situ* produced O<sub>2</sub> and CO<sub>2</sub>, it can be used to quantify the effect of these metabolic interactions. By fitting  $\mu_{max}^i$  using experimental data for the different cases (Cases A, B and C), we could compare the effect of the additional interspecies metabolic interactions on the coculture growth. Table 1 lists the fitted maximum growth rates for both species in Case A and B, and Case C shares the same model parameter as Case B, as there were no other interspecies interactions in Case C. The model-fitted growth curve for both species in three cases were also plotted in Fig. 3b and 3c. These figures demonstrated the excellent agreement between the model fitting and experimental measurements, suggesting the lumped parameters were adequate in capturing the effect of the additional metabolic interactions on the growth of both species in the coculture.

Table 1. The maximum growth rate of methanotroph and photoautotroph in single and coculture

Max. growth rate $\mu_{max}^i$ (hr <sup>-1</sup> )	Methanotroph	Photoautotroph
Single culture	0.098	0.024
Coculture	0.145	0.034
Enhancement	48%	41.6%

Table 1 showed that the maximum growth rate of both species in the coculture showed significant improvement compared to their single cultures, 48% for *M. buryatense* and 42% for *A. platensis*. Since  $\mu_{max}^i$  captures the effect of the additional interspecies metabolic interaction only, the significantly increased  $\mu_{max}^i$  not only confirms the existence of the additional metabolic interactions, but also quantifies their effect on the growth of both species in the coculture. In addition, as the methanotroph in the coculture relies on the oxygen produced by the photoautotroph to grow, it has been argued that the methanotroph may be the only partner that benefits from the coculture environment. Our results clearly suggest that this is not the case, as both species exhibited significantly enhanced maximum growth rates.

#### 4. IDENTIFY THE METABOLITES BEING EXCHANGED WITHIN THE COCULTURE

After confirming the existence of the additional emergent metabolic interactions and quantifying their positive effect on the growth of both species, we intend to identify the specific metabolites that are exchanged between the partners within the coculture. Such understanding will provide valuable guidance on the design of experiments to confirm the identity of the exchanged metabolites within the coculture, as well as the metabolic engineering of the coculture for biotechnology applications. To achieve this goal, we explore genome-scale modeling for the M-P coculture.

GEM has been recognized as a highly effective tool to elucidate complex cellular metabolism, and several GEM approaches have been developed to model microbial communities in the past decade (Colarusso et al., 2021). Fig. 4 uses the M-P coculture to illustrate the considerations involved in developing a GEM for microbial communities. Besides all the metabolic reactions within each of the microorganisms, the metabolic exchanges between different species and the biomass abundances of each organism must also be considered. In addition, each microorganism has its specific nutrient requirements for growth, which can be met through metabolic cross-feeding or consumption from the environment. In such systems, the actions of individual species are constrained by their own biochemical processes and by their interactions with other species.

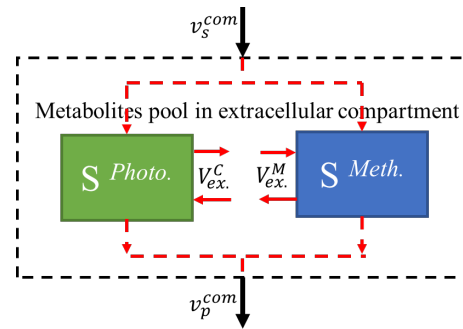

Figure 4. Schematic diagrams of coculture GEM model

In this work, we utilize the Microbiome Toolbox to develop the very first community GEM for the model M-P coculture (<https://github.com/opencobra/cobratoolbox/tree/master/src/analysis/multiSpecies/microbiomeModelingToolbox/>). The refined GEMs for *M. buryatense* 5GB1 and *A. platensis* were used as inputs to the Microbiome Toolbox. Interspecies metabolic interactions can be predicted by the coculture GEM as it includes a common lumen compartment, in which each organism can excrete a metabolite into or uptake a metabolite from. When performing flux balance analysis (FBA) using the coculture GEM, the objective function is set to maximize the biomass production of both species. The linear programming solver Gurobi™ (Gurobi Optimization, LLC) was used to solve the optimization problem in FBA.

In this work, to improve the accuracy of the predicted metabolites being exchanged within the coculture, additional constraints were applied when we performed FBA using the coculture GEM. These constraints include the measured rates of net CO<sub>2</sub> and CH<sub>4</sub> consumption by the coculture. In addition, since there was no O<sub>2</sub> contained in the feeding gas and no O<sub>2</sub> detected in the gas phase during the experiment, the net O<sub>2</sub> flux for the coculture was set to zero, which means that the only O<sub>2</sub> source for *M. buryatense* 5GB1 growth is O<sub>2</sub> produced by *A. platensis* and that all produced O<sub>2</sub> must be consumed by the *M. buryatense* 5GB1.

Before using the Microbiome Toolbox with the community GEM to predict the potential metabolic interactions within the M-P coculture, we first validated the developed GEM by comparing the model predictions with experimental

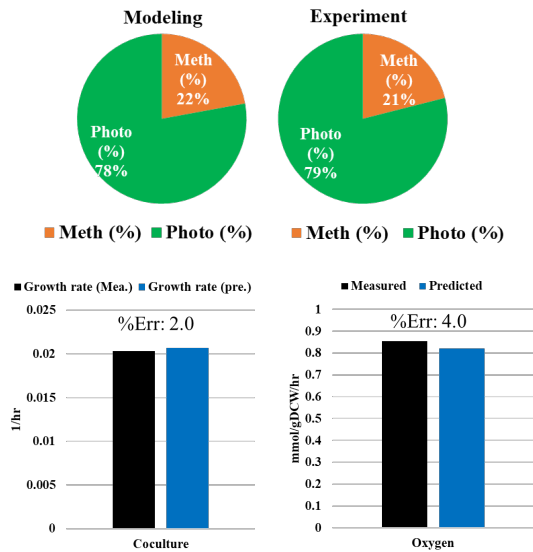

Figure 5. Comparison between the experimental data and coculture GEM prediction of (a) population ratio; (b) coculture growth rate and oxygen consumption by the methanotroph.

measurements for the following variables: population ratio of both species in the coculture, the growth rate of the coculture and  $O_2$  consumption rate for the methanotroph (averaged over 32 hr - 64 hr). The validation results are provided in Fig. 5, which shows that the coculture GEM predictions agree very well with the experimental measurements. Fig. 6 visualizes the

interspecies interactions within the coculture predicted by the coculture GEM, which include the exchange of metabolites involved in central carbon metabolisms,  $NH_4$  and different amino acids. Note that in the Microbiome Toolbox, the base unit for flux calculation is unit mass of the coculture (i.e., gram dry cell weight of coculture), instead of individual species in the coculture, the fluxes of the exchanged metabolites would have the same magnitude but different sign (direction) for the methanotroph and cyanobacteria, as shown in Fig. 6.

In addition, we have examined several *in silico* setups for the coculture GEM, by constraining the exchange of some key metabolites in the tricarboxylic acid (TCA) cycle, such as pyruvate and malate (Wang et al., 2019). It has been suggested that these central metabolites should be excluded from being exchanged due to their key roles in the cellular metabolism; if they are left unconstrained, there may not be any feasible solutions for the coculture GEM. In this work, we have tested six different *in silico* setups (as shown in Table 2) by allowing one or two of these central metabolites to be exchanged within the coculture GEM. Among different setups, the coculture GEM predicted the same top exchanged metabolites that contribute to the enhanced growth of the cocultured partners. The top predicted exchanged metabolites are listed in Table 3. It is worth mentioning that the metabolic exchanges predicted by the coculture GEM agree well with literatures, as existing research on different microbial communities suggests that metabolites in TCA cycle and amino acids are the main cross-fed metabolites (Heinken and Thiele, 2015).

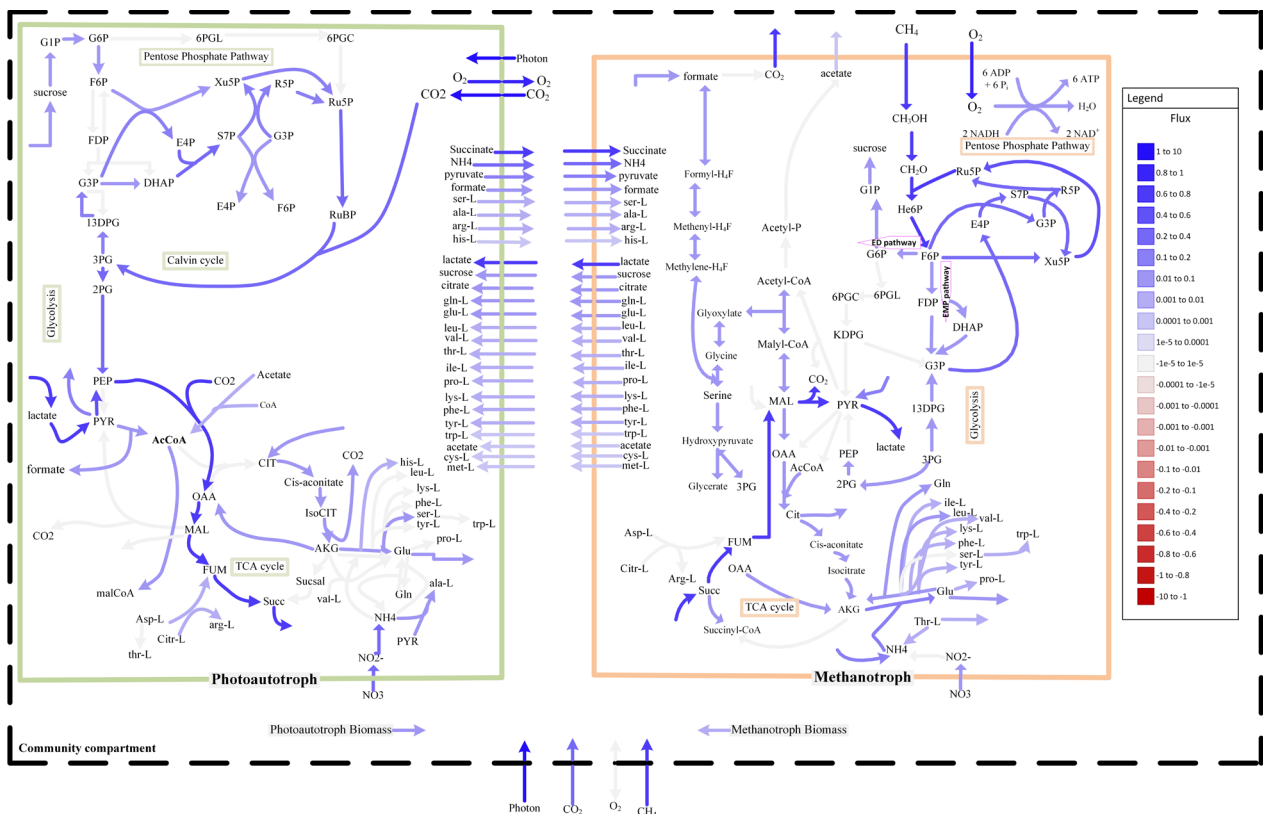

Figure 6. Visualization of the GEM predicted metabolic exchange within the model M-P coculture

Table 2. Different *in silico* setups for the coculture GEM

Setup	Included Metabolites	Excluded Metabolites
1	malate/pyruvate	succinate, oxaloacetate, fumarase, alpha-ketoglutarate
2	pyruvate	succinate, malate, oxaloacetate, fumarase, alpha-ketoglutarate
3	pyruvate/succinate	malate, oxaloacetate, Fumarase, alpha-ketoglutarate
4	succinate	pyruvate, malate, oxaloacetate, fumarase, alpha-ketoglutarate
5	malate/succinate	pyruvate, oxaloacetate, fumarase, alpha-ketoglutarate
6	malate/alpha-ketoglutarate	succinate, oxaloacetate, fumarase, pyruvate

Table 3. The top predicted exchanged metabolites by the GEM

succinate	NH <sub>4</sub>	formate	citrate
sucrose	glutamate	pyruvate	glutamine

## 6. CONCLUSIONS

Existing work, including our own prior work, have demonstrated that M-P coculture offer a highly promising technology platform for effective and efficient biogas conversion. It has been suggested that in addition to the exchange of *in situ* produced O<sub>2</sub>/CO<sub>2</sub> within the coculture, there may exist other emergent metabolic interactions that could further enhance the growth of the coculture and play a pivotal role in determining the composition and function of the M-P coculture. However, little knowledge on these emergent metabolic interactions is currently available.

In this work, by integrating experimental design and mathematical modeling, we were able to validate the existence of the additional metabolic interactions within the M-P coculture, quantify their effects on the coculture growth, and postulate the specific metabolites that are exchanged with the coculture. By designing experiments to compare the coculture with its sequential single culture, and a hypothetical coculture where the exchange of *in situ* produced O<sub>2</sub> and CO<sub>2</sub> is the only interspecies interaction, we were able to validate the existence of additional emergent metabolic interactions within the coculture. Then using the experimental data to fit the model parameters of a semi-structured kinetic model we developed recently, we were able to quantify the gross positive effect of these emergent metabolic interactions on the growth of each organism in the coculture, although the metabolites being exchanged are unknown. To postulate the specific metabolites that are exchanged between the methanotroph and the photoautotroph, we developed the first coculture GEM for the model M-P coculture, which consistently predicted the top 8 metabolites that were exchanged under different *in silico* setups. Additional wet lab experiments are needed to validate these predictions.

## REFERENCES

- Badr, K., He, Q.P., Wang, J., 2022. A novel semi-structured kinetic model of methanotroph-photoautotroph cocultures for biogas conversion. *Chemical Engineering Journal* 431, 133461.
- Badr, K., Hilliard, M., Roberts, N., Peter He, Q., Wang, J., 2019. Photoautotroph-methanotroph coculture - A

- flexible platform for efficient biological CO<sub>2</sub>-CH<sub>4</sub> co-utilization, in: *IFAC-PapersOnLine*.  
<https://doi.org/10.1016/j.ifacol.2019.06.179>
- Badr, K., Whelan, W., He, Q.P., Wang, J., 2021. Fast and easy quantitative characterization of methanotroph-photoautotroph cocultures. *Biotechnology and Bioengineering* 118, 703–714.  
<https://doi.org/10.1002/bit.27603>
- Baldini, F., Heinken, A., Heirendt, L., Magnusdottir, S., Fleming, R.M.T., Thiele, I., 2019. The Microbiome Modeling Toolbox: from microbial interactions to personalized microbial communities. *Bioinformatics* 35, 2332–2334.  
<https://doi.org/10.1093/bioinformatics/bty941>
- Colarusso, A. V., Goodchild-Michelman, I., Rayle, M., Zomorodi, A.R., 2021. Computational modeling of metabolism in microbial communities on a genome-scale. *Current Opinion in Systems Biology* 26, 46–57.  
<https://doi.org/10.1016/J.COISB.2021.04.001>
- EPA, 2021. Livestock Anaerobic Digester Database | US EPA [WWW Document]. URL  
<https://www.epa.gov/agstar/livestock-anaerobic-digester-database> (accessed 11.4.21).
- Heinken, A., Thiele, I., 2015. Anoxic Conditions Promote Species-Specific Mutualism between Gut Microbes In Silico. *Appl. Environ. Microbiol.* 81, 4049–4061.  
<https://doi.org/10.1128/AEM.00101-15>
- Kip, N., Van Winden, J.F., Pan, Y., Bodrossy, L., Reichart, G.J., Smolders, A.J.P., Jetten, M.S.M., Damsté, J.S.S., Op Den Camp, H.J.M., 2010. Global prevalence of methane oxidation by symbiotic bacteria in peat-moss ecosystems. *Nature Geoscience* 3, 617–621.  
<https://doi.org/10.1038/ngeo939>
- Milucka, J., Kirf, M., Lu, L., Krupke, A., Lam, P., Littmann, S., Kuypers, M.M.M., Schubert, C.J., 2015. Methane oxidation coupled to oxygenic photosynthesis in anoxic waters. *ISME Journal* 9, 1991–2002.  
<https://doi.org/10.1038/ismej.2015.12>
- Palsson, B.O., 2015. Systems biology: Constraint-based reconstruction and analysis. *Systems Biology: Constraint-Based Reconstruction and Analysis* 1–531.  
<https://doi.org/10.1017/CBO9781139854610>
- Raghoebarsing, A.A., Smolders, A.J.P., Schmid, M.C., Rijpstra, W.I.C., Wolters-Arts, M., Derksen, J., Jetten, M.S.M., Schouten, S., Damsté, J.S.S., Lamers, L.P.M., Roelofs, J.G.M., Op Den Camp, H.J.M., Strous, M., 2005. Methanotrophic symbionts provide carbon for photosynthesis in peat bogs. *Nature* 436, 1153–1156.  
<https://doi.org/10.1038/nature03802>
- Roberts, N., Hilliard, M., He, Q.P., Wang, J., 2020. A Microalgae-Methanotroph Coculture is a Promising Platform for Fuels and Chemical Production From Wastewater. *Frontiers in Energy Research* 8, 230.  
<https://doi.org/10.3389/fenrg.2020.563352>
- Wang, P.-H., Correia, K., Ho, H.-C., Venayak, N., Nemr, K., Flick, R., Mahadevan, R., Edwards, E.A., 2019. An interspecies malate-pyruvate shuttle reconciles redox imbalance in an anaerobic microbial community. *The ISME Journal* 2019 13:4 13, 1042–1055.  
<https://doi.org/10.1038/s41396-018-0333-4>