

Trays for any Application

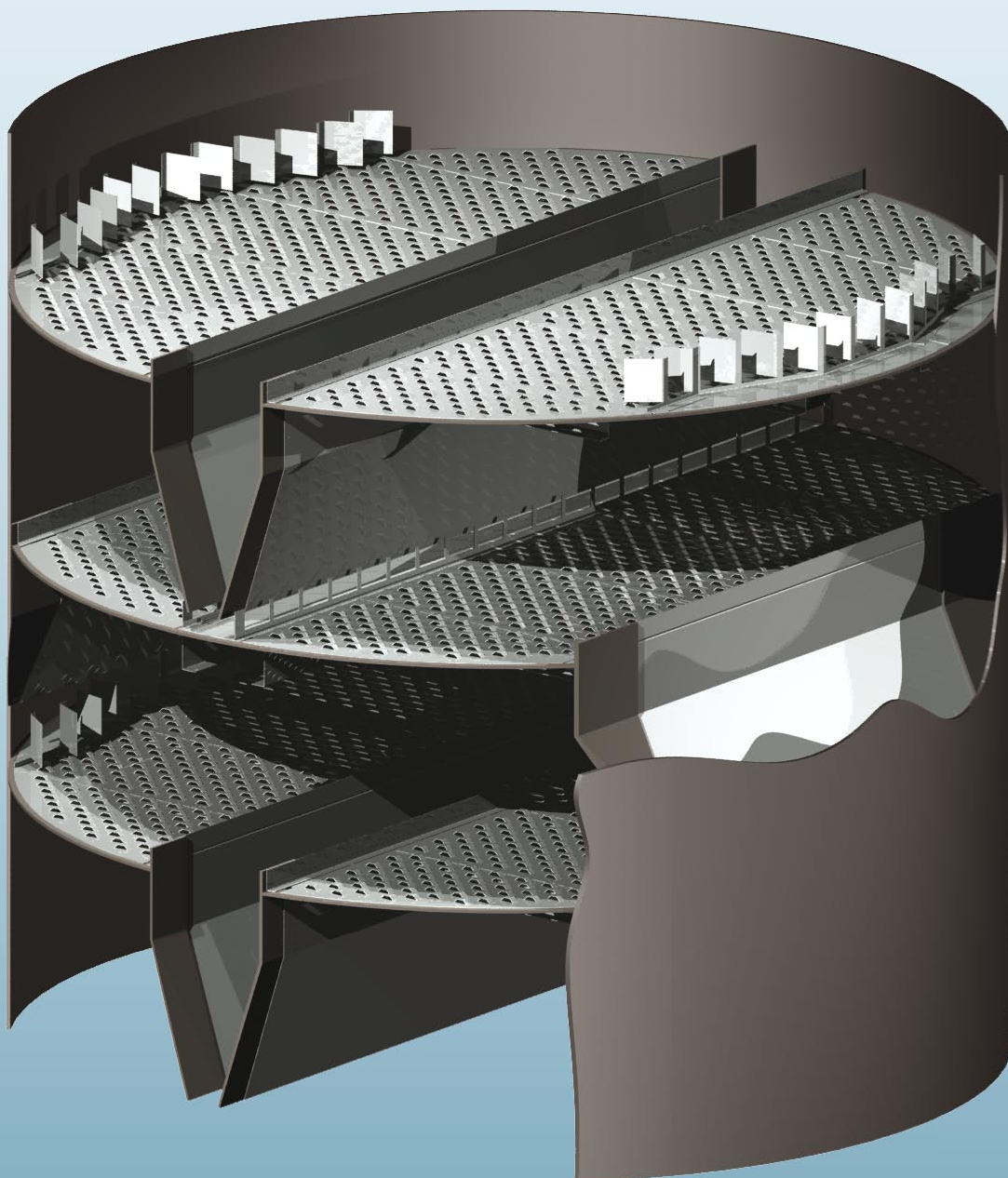

Trays for any Application

Sulzer Chemtech offers the largest tray portfolio on the market. Whatever the requirements, we have the right tray! Continuous innovations and improvements are:

- First movable valve
- First fixed valve
- First customer tray design program
- Use of push valves on commercial trays
- Alliance with Shell Global Solutions to widen our tray portfolio
- Incorporation of fixed valves on multi downcomer trays
- Development of VGPlus
- Highest capacity tray ever tested – ConSep tray

We have been a leader in the development of high performance trays for many years. We led the way with MVG high performance tray decks and continue to provide cutting edge high performance tray technology with VGPlus and Consep trays.

Our position on the tray market has been strengthened by the Alliance of Technology with Shell Global Solutions. The complete Shell Mass Transfer Technology portfolio including high performance trays and associated internals is available from Sulzer Chemtech since 2000.

The Shell-Sulzer alliance combines extensive resources and vast experience. Sulzer Chemtech has five decades of knowledge as global mass transfer supplier offering process know-how, design competence, manufacturing and installation practice, as well as a world wide presence and supply chain. Shell has designed, applied and operated high performance mass transfer technology for the past five decades. Now the combined research and development pushes these technologies continuously to new limits.

Our global expertise and wide array of conventional and high performance tray technologies allow us to provide you with an optimum solution for your demanding requirements of each service.

Content

Trays for any Application	2
Tray Portfolio	3
Sulzer V-Grid Trays: SVG, MVG and MMVG	4
Sulzer VGPlus Trays	6
Sulzer VG AF Trays	8
Shell Calming Section Trays	9
Shell HiFi Trays	10
Shell Calming Section Plus and HiFi Plus Trays	11
Shell ConSep Trays	12
Shell Speciality Trays: Swirl Tube Trays, HiFi Extraction Trays	14
Shell Schoepentoeter	15
Sulzer Sieve and Float Valve Trays	16
Other Trays	17
Tray Hardware, Auxiliaries and Services	18

Tray Portfolio

Sulzer Chemtech is the unique mass transfer component supplier on the market with a complete tray portfolio. The available trays range from conventional to high

performance chordal downcomer, multi-downcomer, and finally to the latest developments of ultra-system limit trays.

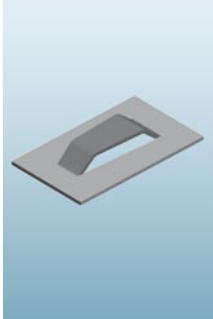
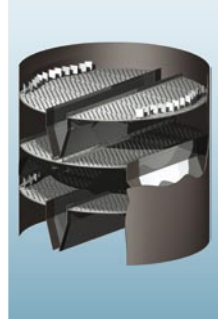
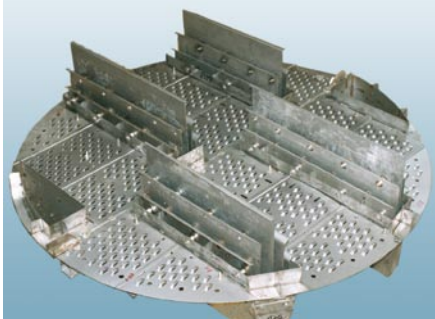
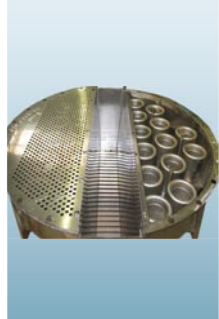
Sulzer Technology			Sulzer-Shell Alliance	
Conventional Trays	Chordal Downcomer High Performance Trays		Multi Downcomer High Performance Trays	Ultra-System Limit HPT
Floating Valves	Enhanced Deck	Enhanced Deck and Downcomer	Calming Section (CS)	ConSep
BDH	MVG	VGPlus	CS Plus	
Round Valve	MMVG	VG AF (Anti-Fouling)	HiFi	
Fixed Valves			HiFi Plus	
SVG			Swirl Tube	
Other Trays			HiFi Extraction	
Sieve				
Bubble Cap				
Dual Flow				
Baffle				
Shower Deck				
Disc and Donut				
Cartridge				
				
BDH Valve	MVG Valve	VGPlus	HiFi Plus	ConSep

Sulzer Conventional Trays

V-Grid Trays

The V-Grid tray technology utilizes a fixed valve and combines the attributes of sieve and float valve trays. The tapered, rectangular valves are extruded from the tray deck and oriented parallel to the liquid flow providing unique advantages compared to traditional sieve trays:

- Lower froth height, less entrainment due to lateral vapor release
- Increased capacity and improved turndown compared to sieve trays
- High efficiency over a wide operating range through improved vapor-liquid contact
- Superior mechanical strength by increased stiffness of tray deck, no moving parts and therefore no wear
- Excellent fouling resistance

Smaller valves provide more capacity than larger ones due to reduced pressure drop and entrainment rate. To meet your requirements we offer following standard sizes: SVG, MVG and MMVG.

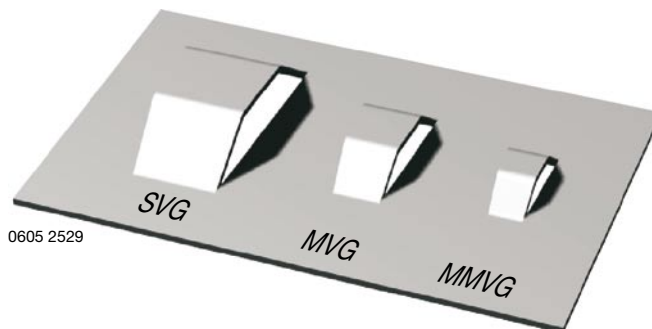
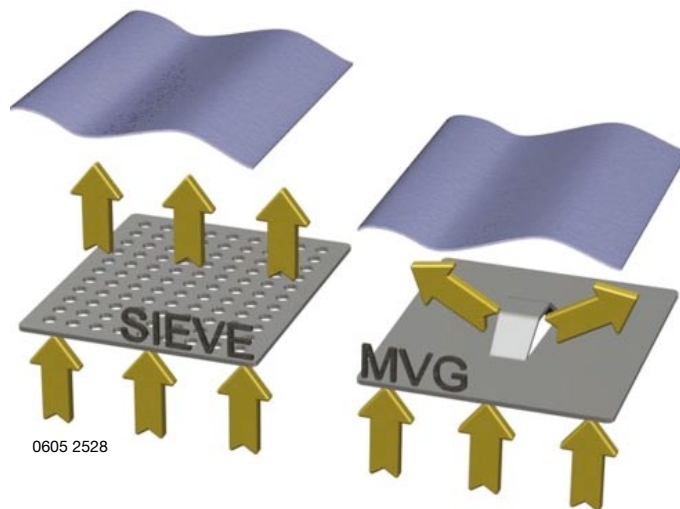

SVG Trays

The SVG trays offer the largest available fixed valve. The large lateral openings produce a vapor cleaning effect on the tray deck which results in an excellent operational performance in fouling services guaranteeing a long run time.

SVG trays have been successfully applied in a variety of fouling services such as Acrylonitrile, Amine Contactors, Atmospheric and Vacuum Columns, Beer Towers, Butadiene, Caustic Towers, Cumene Units, Depropanizers, Debutanizers, HF Alkylation Units, Latex Strippers, PVC Slurry Strippers, Primary Fractionators and Waste Water Towers.

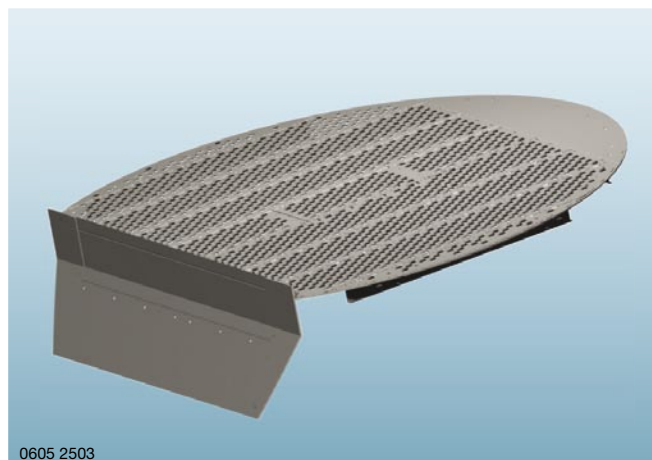

Sulzer High Performance Trays

Sulzer Chemtech's high performance trays combine special tray decks for superior vapor capacity with state-of-the-art downcomer technology for increased liquid capacity. Our proprietary high performance trays should be considered for every column revamp and to decrease the size of new towers.



MVG Trays

MVG trays provide higher capacity compared to standard sieve or valve trays, while providing higher efficiency and lower pressure drop per theoretical stage. The MVG tray deck offers better turndown capability than a sieve tray, i.e. up to 3:1.

MVG trays are well proven in various industrial applications ranging from low to high pressure distillation, i.e. Atmospheric towers to C3 Splitters.

They have been successfully tested at the independent Fractionation Research, Inc. (FRI) in the C6/C7 system at 0.34 and 1.65 bar pressure. Measurements showed up to 20 % advantage in capacity and efficiency compared to sieve trays.

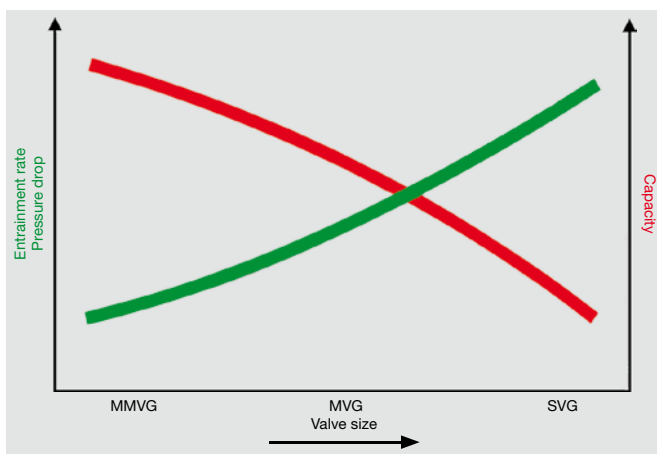

MMVG Trays

MMVG trays are used where extremely high vapor capacity is required. The smaller size opening compared to MVG results in up to 7% additional capacity with equivalent tray efficiency.

Sulzer High Performance Trays

VGPlus Trays

VGPlus are Sulzer Chemtech's high performance chordal downcomer trays. They offer industry proven and FRI validated advanced tray technology for today's market.

VGPlus tray technology is the combination of enhanced tray deck design with high performance downcomers:

- The use of optimized valve layouts, redirecting and froth promoting devices enhances the vapor/liquid interaction on the tray deck.
- Improved downcomer technologies, such as sloped, truncated, stepped and multi-chordal downcomers, reduces downcomer flood and backup, while the tray deck area is maximized.

This combination provides maximum capacity and tray efficiency.

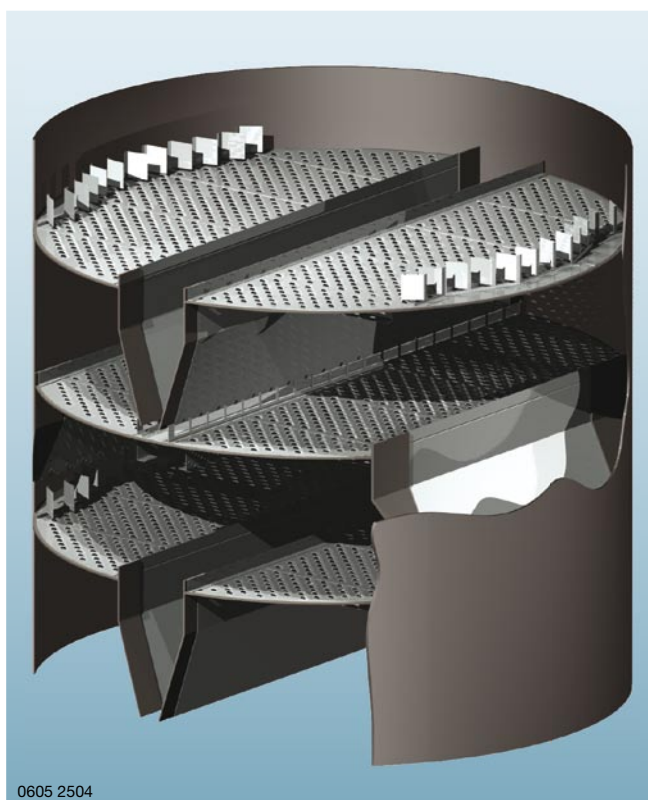

2-pass VGPlus with Baffle Bar™ and Truncated Downcomers

Computational Fluid Dynamics (CFD) assists Tray Development

Research and pilot testing has been supported by CFD special modeling techniques, enabling Sulzer to study complex two-phase phenomena, e.g. froth flow and liquid entrainment.

The figure represents the fluid distribution on the tray deck as a function of time. The lower row shows how the redirecting system creates a more uniform flow.

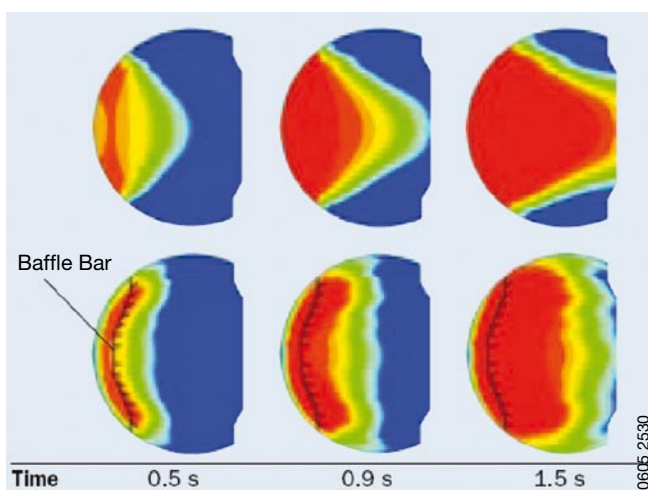

Sulzer High Performance Trays

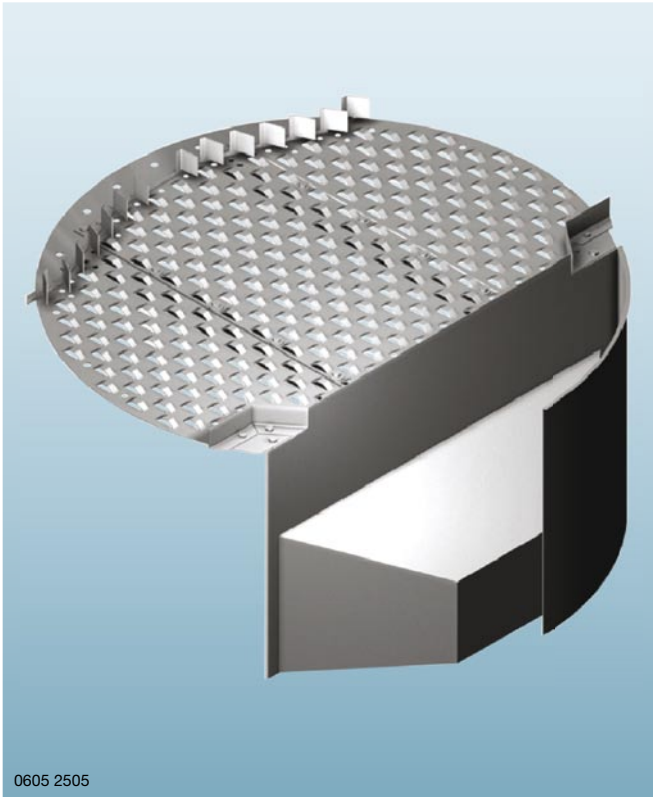

0605 2505

1-pass VGPlus with Baffle Bar and Steparc™ Downcomer

VGPlus vs Conventional Trays

- Higher capacity: up to 30%
- Lower pressure drop: up to 20%
- Equal or higher efficiency
- Elimination of hydraulic gradient
- Uniform liquid flow and vapor distribution

Fields of Application

- Revamp and grassroots
- From atmospheric to high pressure systems
- Medium to high flow parameters

Typical Applications

- C2 and C3 Splitters
- Demethanizers, Deethanizers, Depropanizers, Debutanizers, De-Isobutanizers
- Main and Primary Fractionators

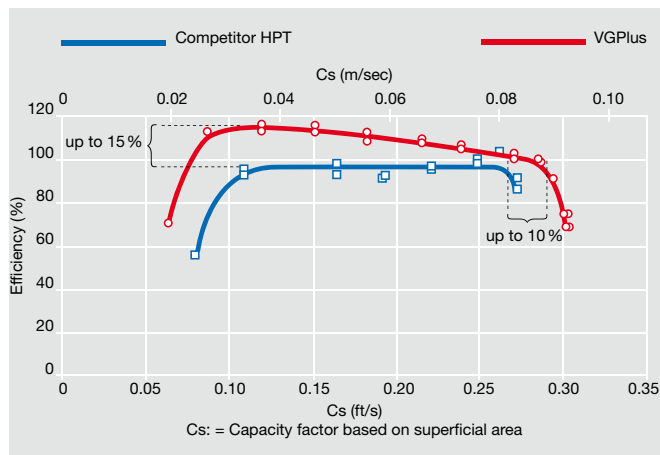

FRI Validation in High Pressure Tower

The superiority of the VGPlus tray technology has been confirmed by independent experiments at FRI.

The tray has been tested in the 1.2 m diameter tower at 7 and 11 bar with i-C4/n-C4 system. VGPlus is one of the best ever tested high performance chordal downcomer trays.

Sulzer High Performance Trays

VG AF™ Trays

VG AF (Anti Fouling) trays are part of the VGPlus tray family and especially designed for fouling services. The combination of large fixed valve, high performance downcomer technology and tailored design features makes the tray less sensitive to plugging and increases the run time of fouling applications.

The VG AF provides superior anti-fouling performance while delivering high capacity and efficiency, making this tray ideal for debottlenecking fouling services.

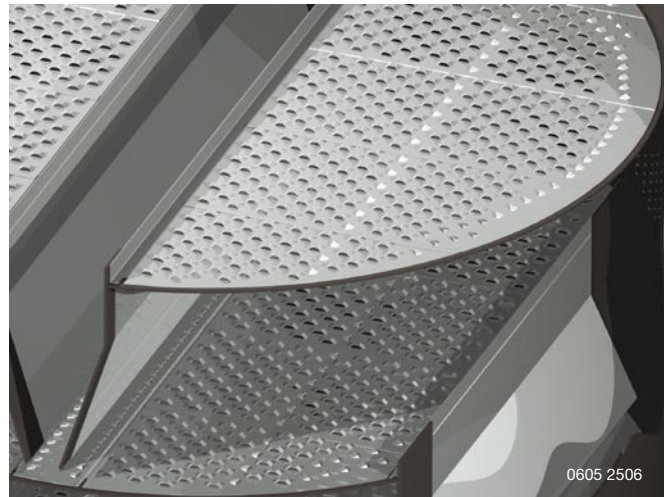

2-pass VG AF with Push Valves

Typical Applications

The VG AF is ideal for boosting capacity of existing towers suffering fouling problems such as:

- Heads and Dry Columns of Acrylonitrile plant
- PVC Slurry Strippers
- Depropanizers
- Debutanizers
- Primary Fractionators in Ethylene Plant
- Stripping section of Atmospheric and Vacuum Towers
- Coker Main Fractionators
- Beer Columns



2-pass VG AF equipped with sloped outlet weir

Mechanically strong, rigid



Vapor passages remain clean even in heavily fouling services



Shell High Performance Trays

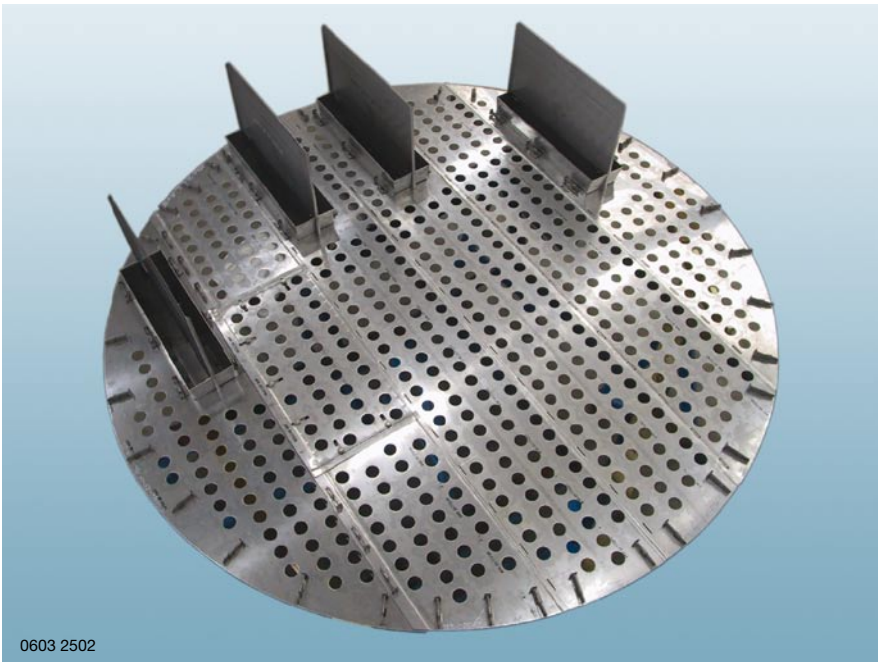

Shell Calming Section Trays

Shell Calming Section trays are normally applied at flow parameters below 0.1 i.e. at moderate liquid rates. They are used to maximize Jet Flood Capacity and minimize entrainment.

Calming Section trays are designed with very large open areas, which combined with the box downcomer design, allows for increases in useful capacity up to 30% over conventional trays. This characteristic also allows for smaller than normal tray spacing down to 300 mm (12").

Flow Parameter Definition

$$\text{Flow Parameter } f = \frac{L}{V} \sqrt{\frac{\rho_V}{\rho_L}}$$

V = vapor flow rate [kg/s]

L = liquid flow rate [kg/s]

ρ_V = vapor density [kg/m³]

ρ_L = liquid density [kg/m³]

Valves

Both Calming Section and HiFi trays can be fitted with following deck designs:

- Sieve
- Round valve
- Snap-In valve
- Caged valve
- MVG
- MMVG
- BDH valve

Different deck types can be used to custom fit the tray design to the specific process application.

Shell High Performance Trays

Shell HiFi Trays

Shell HiFi trays are designed to handle large liquid loads typically for flow parameters larger than 0.1. They are used for applications where the liquid loads are high and can not be accommodated by the Calming section trays.

The major advantage is that the box downcomers provide an outlet weir length double or triple what chordal downcomer trays can provide. This lowers the effective weir loading by 50 % to 70 % substantially lowering the crest over weir on the tray and pressure drop. This results in a significant capacity boost over conventional trays.

HiFi trays are frequently used to increase the number of trays at reduced tray spacing. For example, if higher performance is required in the column a 3-for-2 or 4-for-3 retrain may become an attractive alternative.

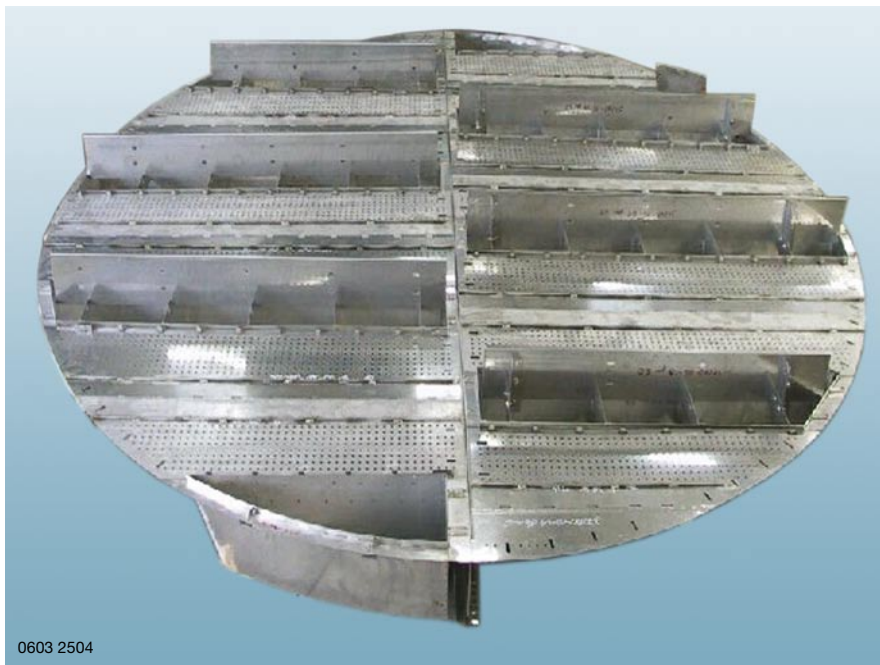

Liquid Flow on Calming Section and HiFi Trays

The blue areas on the pictures represent the position of the box downcomer of the tray above, and where the liquid is discharged on to the tray. The red arrows indicate the liquid flow direction.

On Calming Section trays the liquid flows from one side of the tray to the other by crossing the center line of the tray. This enables a long flow path length and high tray efficiencies.

The HiFi tray is point symmetric around the tray center. The liquid flow path lengths are usually shorter compared to CS trays, but nearly all have the same lengths and head in a perpendicular direction to the box downcomers. This enforces uniform liquid distribution on the different tray panels and a self balancing mechanism which leads to maximum tray efficiency.

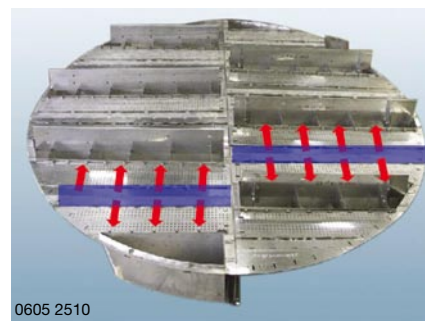
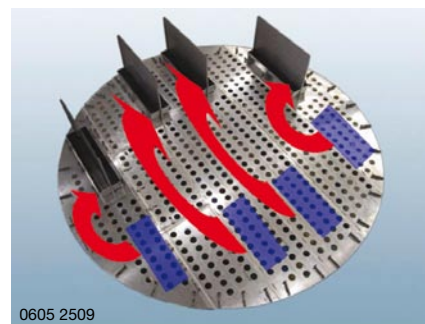

Shell High Performance Trays

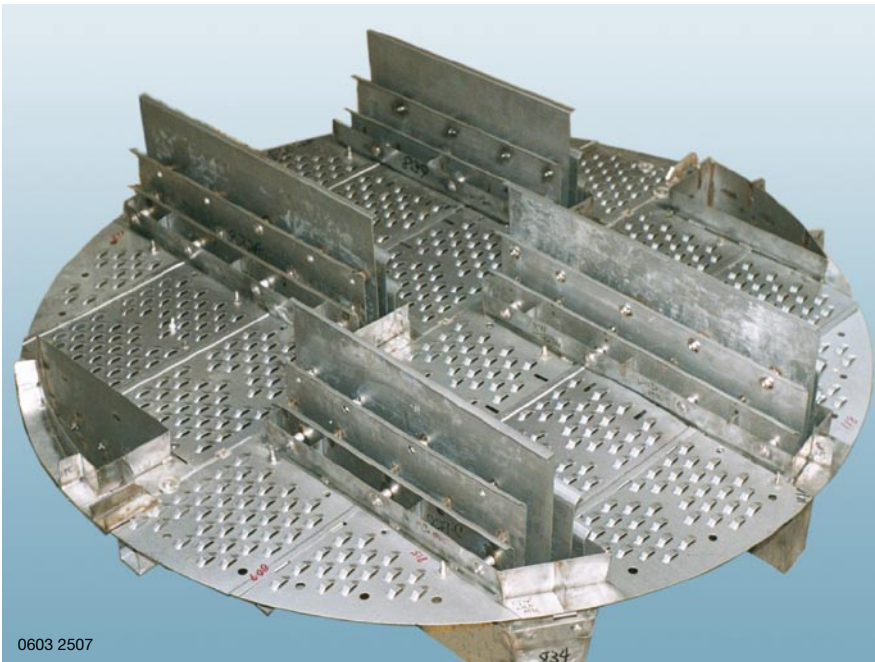

Shell CS Plus and Shell HiFi Plus Trays

Shell Calming Section Plus and HiFi Plus trays are enhanced versions of the standard Calming Section and HiFi trays. These trays incorporate two additional features that boost tray capacity:

- more efficient downcomer designs using Crown Inlet Devices CID™ at downcomer entrance to enhance vapor/liquid disengagement and increase the liquid handling capacity by up to 20% over normal Calming Section and HiFi trays
- high performance tray deck such as MVG fixed valves reduce entrainment and provide maximum useful capacity

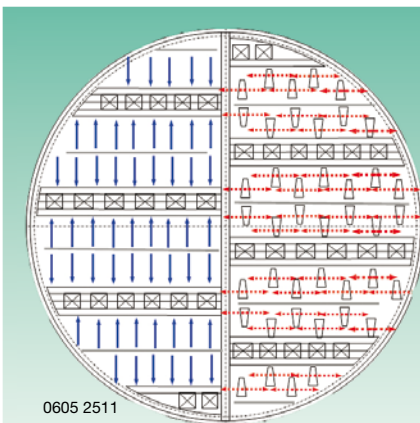

Top view on HiFi Plus tray

Self Balancing Mechanism of Shell HiFi Trays

The unique orientation of the downcomer boxes allows an equal liquid distribution on each tray panel section (blue arrows). The liquid flow path lengths are straight and nearly equivalent.

The vapor is released laterally through the MVG valves perpendicular to the liquid flow (red arrows).

The vapor is distributed uniformly on the tray panels. The combination of equal distribution of vapor and liquid guarantees a good vapor-liquid mixing and is an important criteria for a reliable and a high tray efficiency.

Since there is no obstruction between the different tray compartments, the vapor distribution beneath the bubbling area is very uniform: this makes all Shell HiFi trays the only hydraulically self-balancing multi-downcomer tray available in the market.

Shell Ultra-System Limit High Performance Trays

Shell ConSep Trays

Shell ConSep trays offer up to 80 % higher capacity than conventional trays and up to 50 % higher than any other high performance tray while maintaining high mass transfer efficiency.

ConSep trays utilize the principle of de-entrainment by centrifugal force to exceed the gravitational limitation of jet flood. The decks consist of sieves, movable or fixed valves.

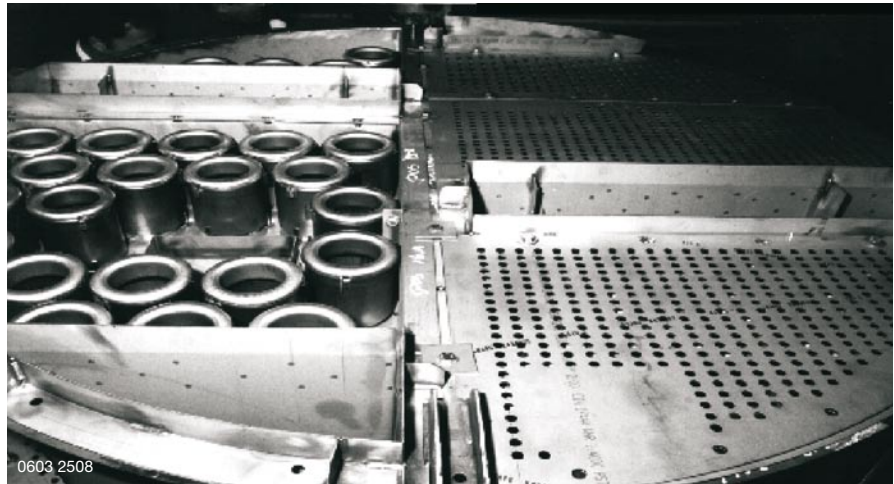

Principle Sketch

Separation of the entrained liquid before entering the next tray allows very high vapor velocities to be achieved in the column.

The tray combines the large bubbling area and liquid handling capacity of the contacting Shell HiFi trays and a centrifugal separator in one single stage: Con(tact) and Sep(arator).

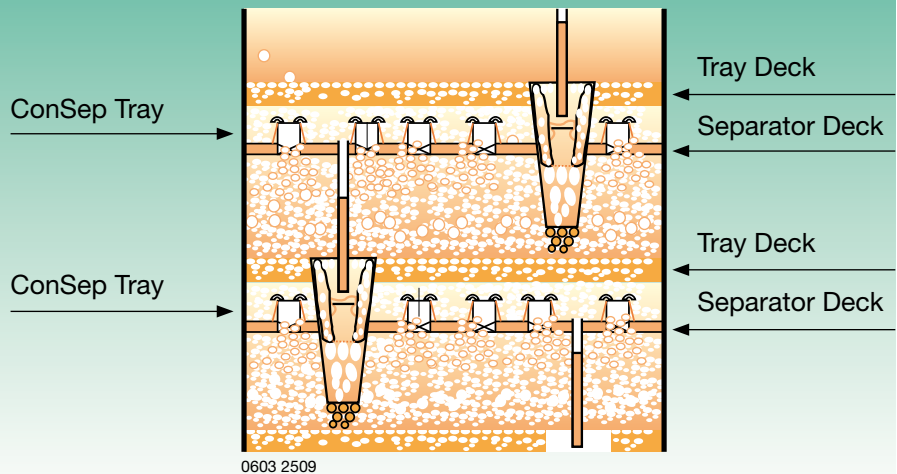

Shell Ultra-System Limit High Performance Trays

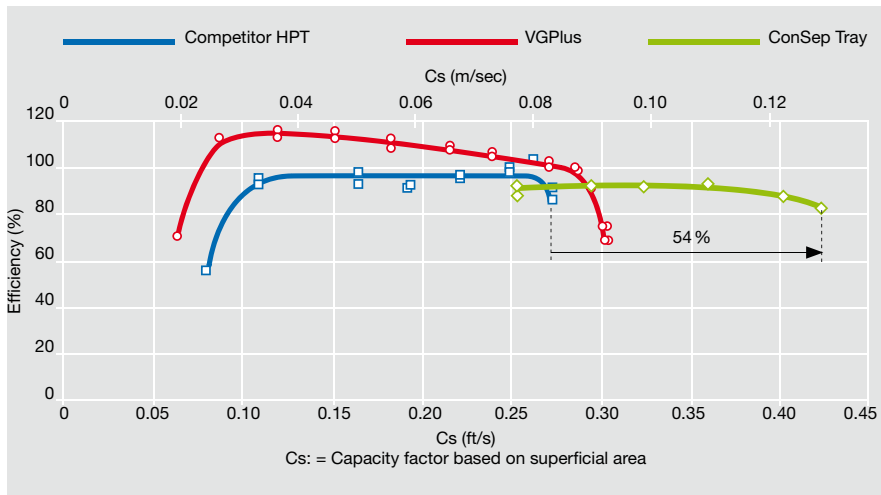

FRI Validation in High Pressure Tower

The FRI test of the ConSep tray was performed in a 1.22 m diameter tower with Iso-butane/n-butane system at 11 bar. The tray used a sieve hole panel and a 2-pass design.

The ConSep tray turned out to have over 50% higher capacity as any other tested high performance tray and a tray efficiency up to 90%. The capacity exceeded FRI's system limit. The ConSep trays have been successfully used in refinery, petrochemical and offshore applications.



2-pass ConSep tray tested at FRI

Typical Applications

Shell ConSep trays can be used reliably in refinery, petrochemical and offshore applications.

Typical applications are Deethanizers, Depropanizers, Debutanizers, Main Fractionators, Pump-arounds, C2 Splitters, C3 Splitters and for cases above the system limit.

The trays have been successfully applied in systems with vapor to liquid ratios close to unity, such as Debutanizers and Main Fractionators.

Shell Speciality Trays

Shell Swirl Tube Trays

Shell Swirl Tube trays offer extremely large capacities at high vapor loads and low liquid loads. They are used at flow parameters below 0.05 and become particularly advantageous below 0.02. These trays are ideal for applications with low liquid rate at high pressure, such as natural gas dehydration with TEG.



Shell HiFi Extraction Trays

Shell HiFi Extraction trays are particularly well suited for systems with interfacial tensions below 25 dyne/cm and large phase ratios.

They can be used to enhance the capacity of existing extractors in aromatics extraction, caustic treating and lube oil applications.

Shell HiFi Extraction vs. RDC in Sulfolane extraction:

- Increased capacity up to 25 % and 20 % more separation stages

Shell HiFi Extraction vs. Conventional Sieve trays:

- Increased capacity up to 15 % at equivalent efficiencies
- Lower tray spacing without capacity loss

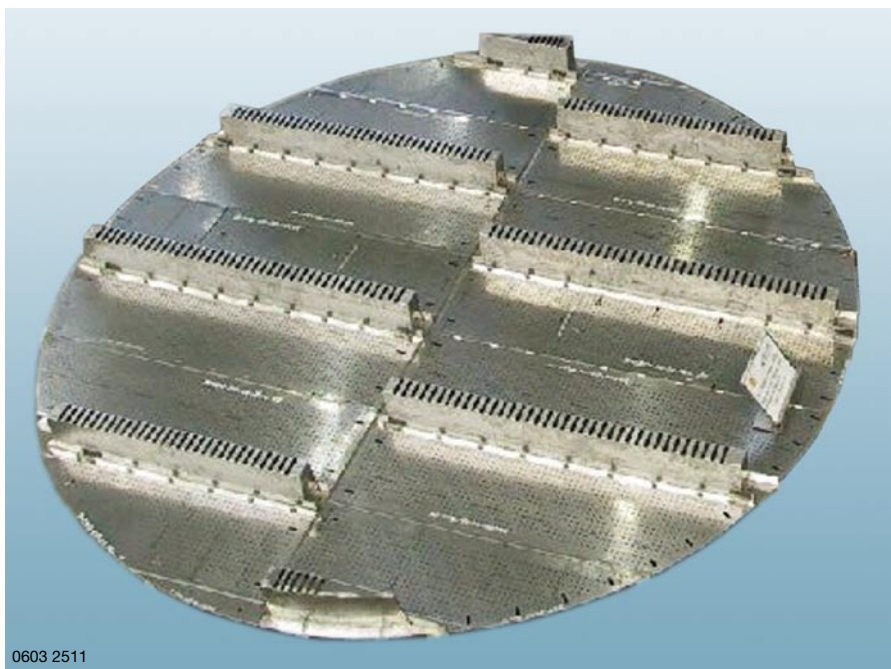

Shell Schoepentoeter

Shell Schoepentoeter vane inlet devices are the lowest pressure drop devices available for two phase feed inlets. They can be used in conjunction with all mass transfer devices, namely trays, structured and random packings.

This device is operating successfully and is best suited for flashing feeds and reboiler returns. The required inlet nozzle is considerably smaller than conventional inlet devices. When debottlenecking, it is often not necessary to enlarge the existing inlet nozzle.

The Schoepentoeter gives excellent distribution, phase separation and operates at negligible pressure drop.

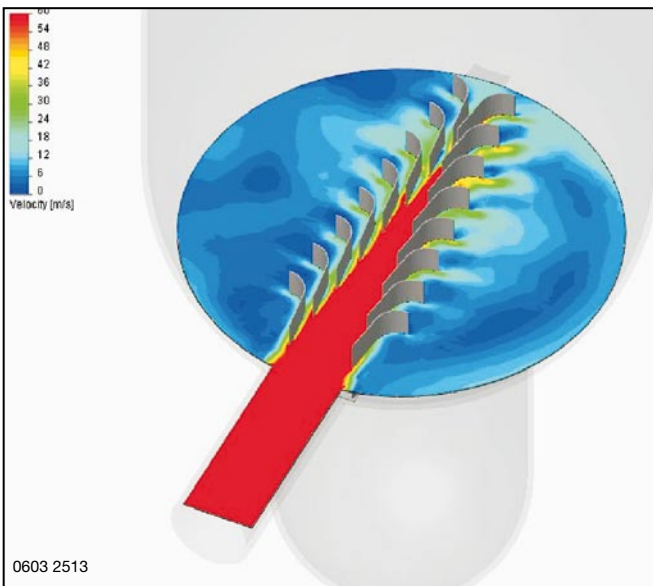
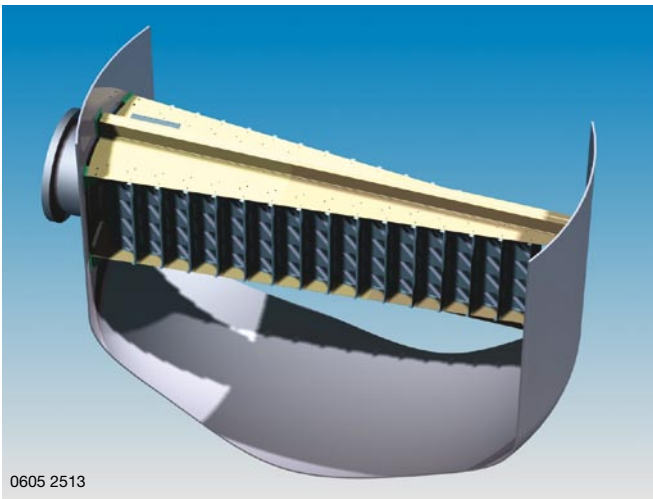

CFD Analysis for optimal design

The design of the Schoepentoeter is adapted to the requirements of the service and the mechanical constraints of the column. CFD studies can further help to optimize the design of devices which many times may have to operate near critical conditions.



Size matters!



Mega Schoepentoeter

Conventional Trays

Sieve Trays

Sieve trays find a wide acceptance as a low cost mass transfer device where high turndown is not required. Sulzer Chemtech offers all common sieve tray designs including small holes for improved vapor capacity and venturi holes for low pressure drop.

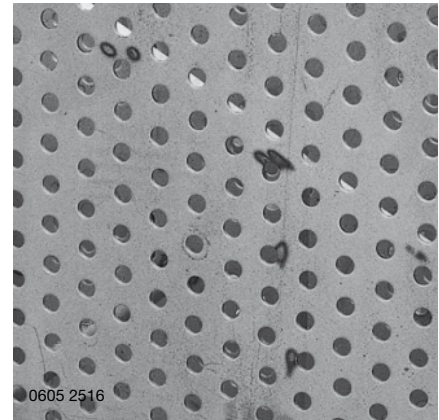

Floating Valve Trays

Valve trays are typically used in basic applications where higher turndown ratios are required. Due to their ability to control vapor flow, they provide a higher sustained efficiency over a wider operating range than sieve trays. Sulzer Chemtech offers conventional round valve trays in addition to its proprietary Float Valve™ trays, such as BDH, Snap-in and Cage valve.

BDH Valve

The unique rectangular-shaped valves set the BDH tray apart from conventional valve trays. The valve is oriented parallel to the liquid flow direction, providing lateral vapor release and a closed upstream edge to minimize weeping. This contributes to an improved efficiency/capacity profile compared to conventional round valve trays. Further advantages of the rectangular valve are:

- Improved liquid flow due to lateral vapor release
- Improved turndown ratio compared to round valves
- The wide legs and lack of valve rotation reduce damage and wear
- Available range of valve lifts and weight allow for optimal design
- The design allows for top side valve replacement

The larger size BDP valve is available for replacement and special applications.



Round Valve



Round valve trays are available for replacement or on special request. They are available with two deck variations: RV1 with flat deck and RV4 with venturi hole for lower pressure drop.

Snap-in Valve



The Snap-in valve is our proprietary round valve. It has a proven track record and is recognized for its ease of installation. Its topside insertion, after tray deck installation, eliminates damage during transportation and simplifies future replacement.

Caged Valve

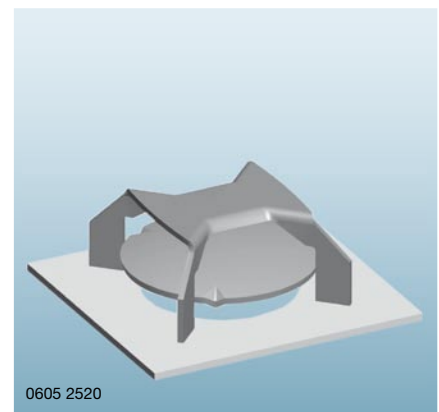

Caged valves are used in applications having low-liquid loads and/or requiring high turndown ratios. Caged valve trays are available for replacement or on special request. For special materials the valve will be laser cut.

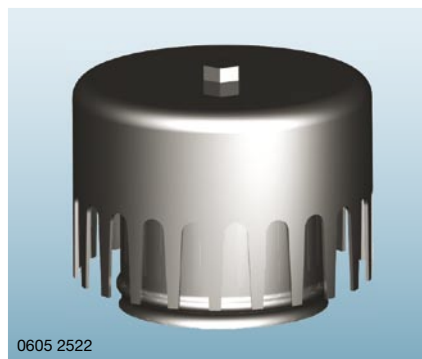

Bubble Cap Trays

Bubble Cap trays are used for low liquid loads and very high turn down ratios. Sulzer Chemtech offers a standard cap for 3" and 4", and a slotted type for 6".

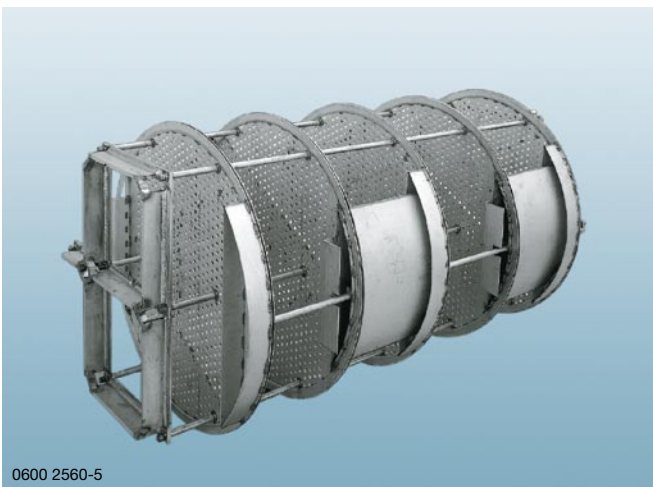

Cartridge Trays

Cartridge trays are typically used in flanged columns where the tower diameter is a standard pipe size and does not allow the passage of a person through the tray. Tower diameters range between 300 to 800 mm (12" to 30"). Cartridge trays are joined together in bundles for easy installation. The trays are available with all types of tray decks and various downcomer designs.

Dual Flow Trays

Dual Flow trays are perforated trays with no downcomer. Due to the absence of downcomer and the large open area, dual flow trays are suitable devices to be used in highly fouling services, e.g. slurries and corrosive applications.

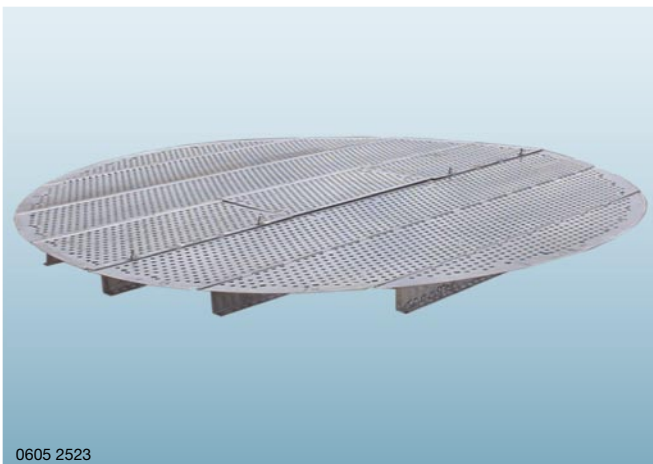

Baffle Trays, Shower Deck Trays, Disc and Donut Trays

These trays are arranged in a tower in such a way that the liquid flows down the column by splashing from one baffle to the next lower baffle, and the ascending vapor passes through the curtains of liquid spray. These trays are used in washing sections where fouling resistance has priority over performance.

Additionally Sulzer Chemtech offers a variety speciality tray our customers may require, e.g. Orbit trays, horse shoe trays etc.

Tray Hardware, Auxiliaries and Services

Lip-Slot™ Panel Connection

The Lip-Slot connection eliminates bolting along the trusses of adjacent tray panels for:

- Accurate positioning of the panel
- Fast and easy installation: up to 30 % faster installation
- Easy disassembly
- Minimal spare parts required

It is combined with through bolting and universal tray clamps for the remaining connections. The Lip-Slot connection has an excellent track record. It is Sulzer's preferred tray panel connection, and can be used for panel thickness up to 3.5 mm.

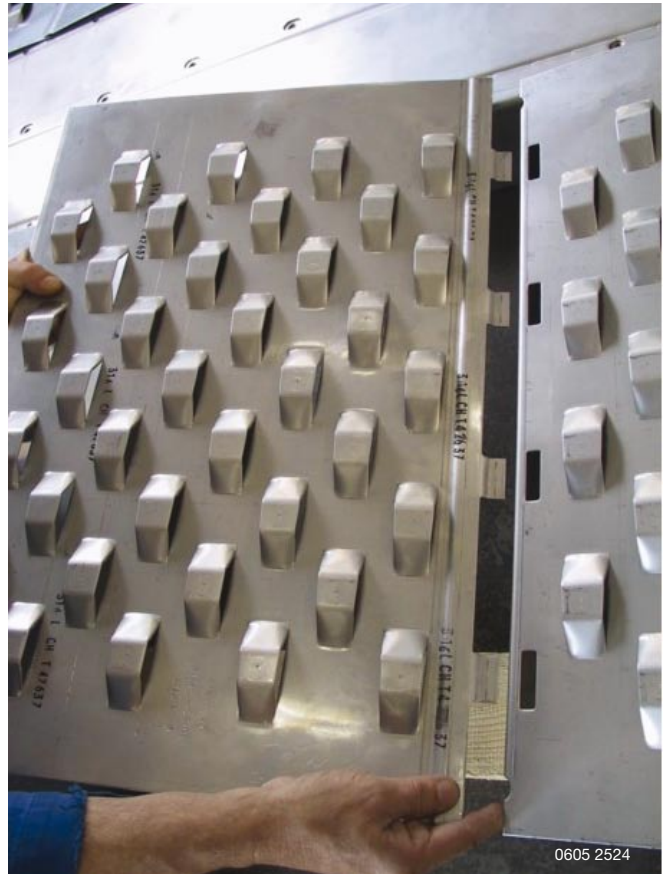

Support Ring Connections

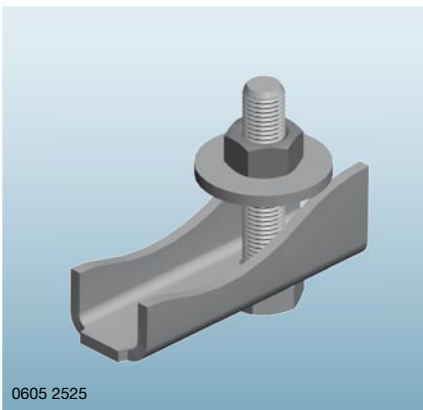

Universal clamp is Sulzer's standard connection to tray supports.

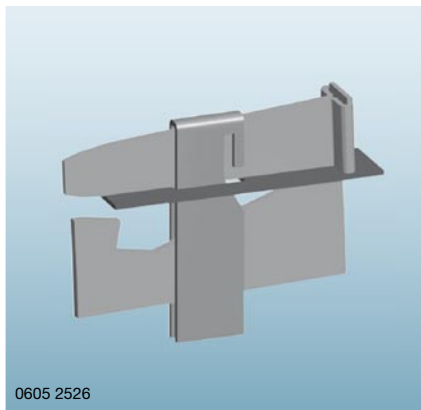

Split-Wedge connections are a proven Sulzer speciality for fast installation and removal.

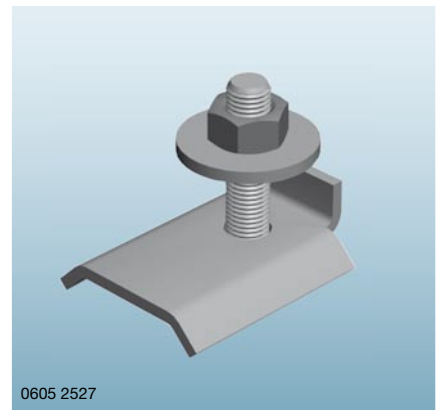

Bolted tray clamp available on request.

Tray Hardware, Auxiliaries and Services

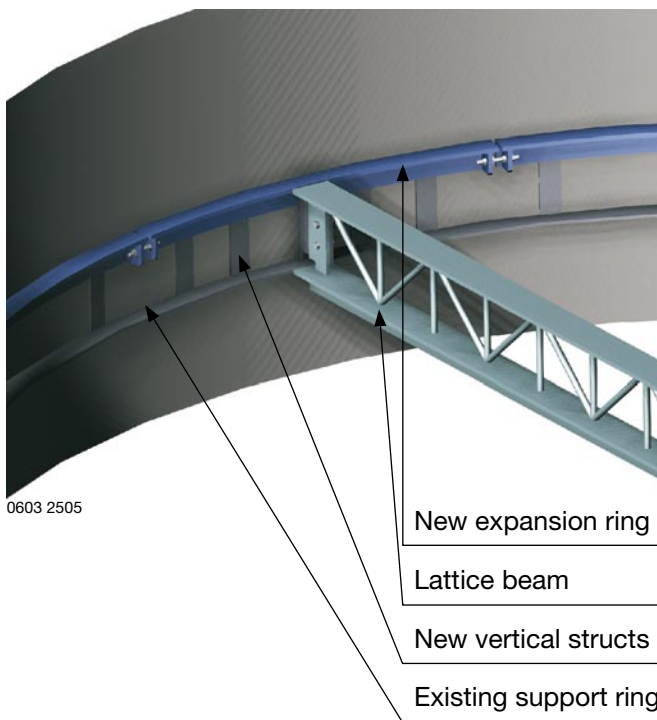

Construction

All Shell and Sulzer trays can be fitted with Sulzer Chemtech's bolt-less Lip-Slot tray panels connection for fast installation and removal. Installation time can be reduced by approximately 30 %.

The Shell trays are placed on 360° support rings (see sketch). Large diameter columns require beams. The use of lattice beams allows a cost and space saving construction. This system requires one beam for the support of two trays and is often used for revamps where 3-for-2 or 4-for-3 retrain is required. No welding work at the column wall is necessary.

Services

Sulzer Chemtech's global manufacturing capabilities ensure fast delivery of any tray hardware and replacement tray parts, regardless of original supplier. These can be manufactured from existing drawings or damaged parts and supplied on site quickly to meet your turnaround schedules. Replacement hardware can be supplied on consignment in lockers or trailers for our customer's convenience during shutdowns.

Headquarters

Sulzer Chemtech Ltd
P.O. Box 65
8404 Winterthur, Switzerland
Phone +41 52 262 50 28
Fax +41 52 262 01 82
chemtech@sulzer.com
www.sulzerchemtech.com

North and South America

Sulzer Chemtech USA, Inc.
8505 E. North Belt Drive
Humble, TX 77396, USA
Phone +1 281 441 5800
Fax +1 281 291 0207

Asia, Pacific

Sulzer Chemtech Pte. Ltd.
10 Benoi Sector
Singapore 629845
Phone +65 6515 5500
Fax +65 6862 7563

Sulzer Chemtech Ltd, a member of the Sulzer Corporation, with headquarters in Winterthur, Switzerland, is active in the field of process engineering and employs some 2500 persons worldwide.

Sulzer Chemtech is represented in all important industrial countries and sets standards in the field of mass transfer and static mixing with its advanced and economical solutions.

The activity program comprises:

- Process components such as trays, structured and random packings, internals for separation columns and reaction technology
- Engineering services for separation and reaction technology such as optimizing energy consumption, plant optimization studies, pre-engineering for governmental approval, basic engineering
- Separation and purification of organic chemicals by means of crystallization and membranes
- Mixing and reaction technology with static mixers
- Mixing and Cartridges Technology
- Tower field services

Distributed by:

