

Structured Packings

for Distillation, Absorption and Reactive Distillation

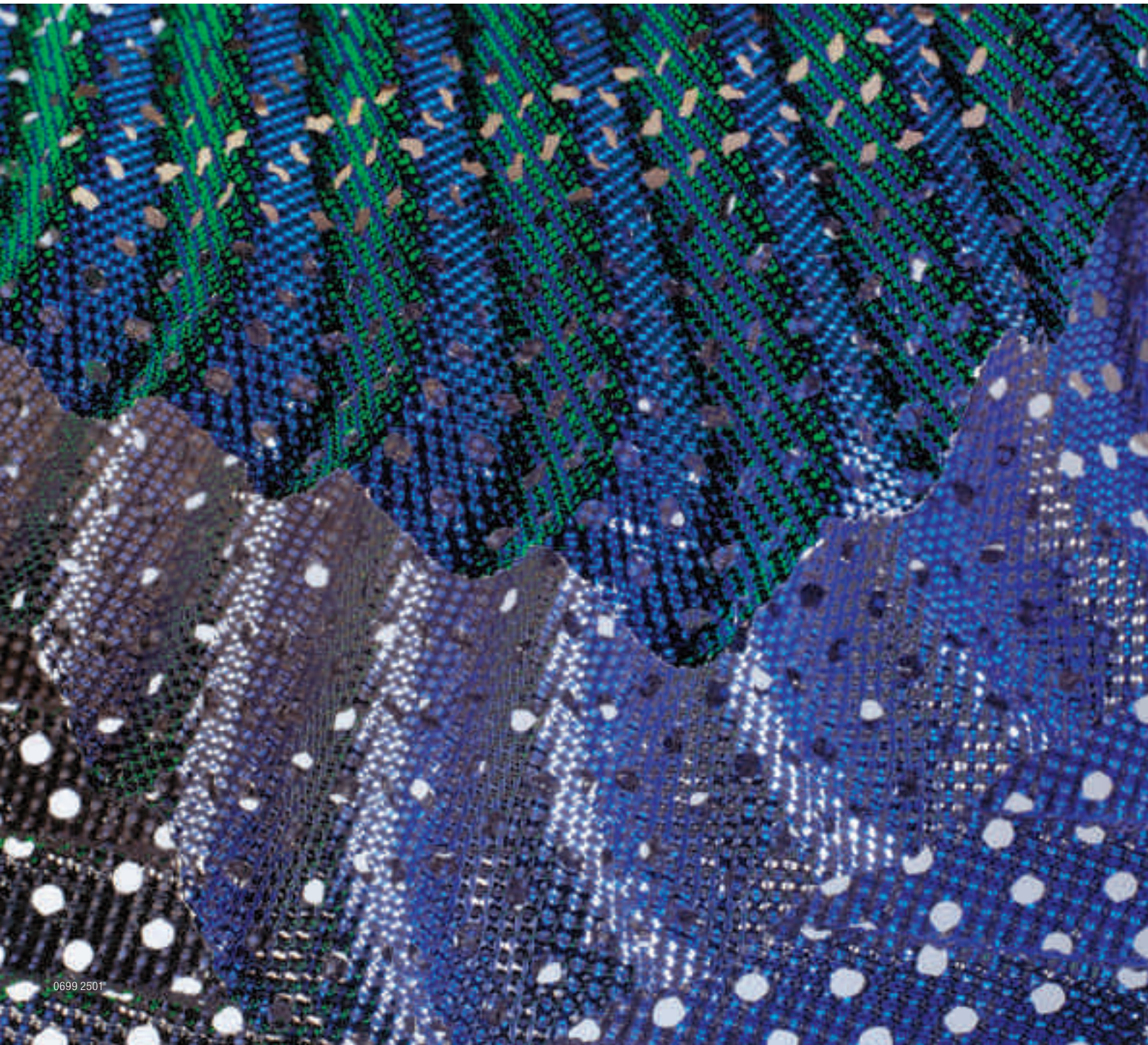

Structured packings for separation and reactive distillation

This brochure was reviewed and supplemented recently. It therefore provides a complete, up-to-date overview of packings available from Sulzer Chemtech.

Also included is a summary covering the essential column internals and our technical services.

For further information and to download our brochures as well as design tools, please refer to www.sulzerchemtech.com

More detailed product information, you will find in the following brochures:

- Internals for Packed Columns

The brochure contains a comprehensive summary of the selection of internals supplied by Sulzer Chemtech, and a description of the most important features of the distributor technology.

- Gas Processing

- Chemical Processing Industry

- Process Technology and Equipment for Oil Refineries and Crude Oil Production

Three brochures which illustrate the wide spectrum of application of structured packings.

Sulcol Design Program

A program that enables users to carry out hydraulic design of columns featuring every type of packing Sulzer Chemtech offers. The program is based on our experience with several thousand industrial columns and from experimental data measured in our own test column with a diameter of 1 m.

Considering the broad selection of products and widely proven application know-how, Sulzer Chemtech is in a position to offer the suitable solution even for the most difficult separation tasks.



Contents

Structured packings

• Overview	4-5
• Laboratory packings	6
• Rombopak	7
• Mellapak®	8-10+15
• MellapakPlus®	11-12
• Gauze packings	13-14+16
• Mellacarbon®	17
• Mellagrid®	18
• Katapak®-SP	19

Internals and erection

• Distributors	20
• Collectors	21
• Support grids	22
• Revamping	23
• Installation	24
• Sulzer columns	25

Test facilities

• Distributor test facility	26
• Pilot plants	26

Column design

• Formula notation	27
--------------------	----

0693 2504-14

50 years of experience in mass transfer technology

Sulzer Chemtech has been active as equipment supplier to the chemical industry since the nineteen forties. In the early days the engineering design was completely dependent on the specification provided by customers. At the end of the fifties Sulzer was ready to offer its own solutions to specific chemical process engineering problems. These early activities laid the corner stone for sustained innovation by establishing an in-house development group and a well equipped pilot facility.

Gauze packings

The invention of the gauze packings BX and CY in the early sixties resulted in a decisive breakthrough in distillation technology. The special advantages of these packings allowed difficult separation tasks to be accomplished for the very first time, and thermally sensitive substances to be separated by means of distillation.



for natural gas drying. In comparison to conventional technology, Mellapak offers substantial benefits in many process applications. During the past 40 years, thousands of columns, originally equipped with trays or random packings, have been revamped with Mellapak in order to improve yield or purity or to increase capacity. Due to extensive



Mellapak

A further milestone was the development of the structured packings Mellapak in the seventies. Originally conceived to cover the moderate vacuum range up to atmospheric pressure, Mellapak opened up new and unforeseen perspectives in all areas of thermal mass transfer.

Applications

The eighties were marked by the widening of the application range of Mellapak in the petrochemical, oil and gas industries as well as in exhaust air cleaning and in the stripping of volatile constituents from wastewater. Typical examples are vacuum towers in refineries and high-pressure absorption columns



test data gathered in our process engineering laboratory as well as experience gained in numerous industrial applications, we are able to offer the best possible solution for your application requirements.

Column Internals

With the concept of advanced internals, Sulzer Chemtech has defined the standard for gas and liquid distribution in packed columns. Distributors are available for a wide range of applications and operating conditions.



MellapakPlus

- MellapakPlus represents the novel, high capacity structured packing (typically 25 to 30 % more capacity compared with conventional structured packing)
- MellapakPlus offers significantly lower pressure drop
- MellapakPlus offers a wide range of technical and commercial advantages
- MellapakPlus can be used from low vacuum up to high pressure applications
- Everything one already knows about Mellapak remains valid for MellapakPlus

Structured packings from Sulzer Chemtech

	Type of packing	Material
	Mellapak 64.X/64.Y Mellapak125.X/125.Y Mellapak170.X/170.Y Mellapak 2 X/2 Y Mellapak 250.X/250.Y Mellapak 350.Y	Mellapak 500.X/500.Y Mellapak 750.Y Further types on request
	MellapakPlus 202.Y MellapakPlus 252.Y MellapakPlus 352.Y MellapakPlus 452.Y MellapakPlus 602Y MellapakPlus 752.Y	Further types on request
	Mellapak 125.X/Y Mellapak 250.X/Y from plastics MellapakPlus 252.Y from plastics	PP, PVC-C, PVDF, Teflon® PFA, PEEK
	Mellagrid 40.Y Mellagrid 64.X Mellagrid 64.Y Mellagrid 90.X	Stainless steels Carbon steel Other materials available on request
	BX gauze packing BXPlus gauze packing CY gauze packing BX gauze packing from plastics	Stainless steels Copper-bronze, monel, hastelloy, nickel, titanium Other materials available on request Gauze - made of polypropylene/polyacrylonitrile mixture (PP/PAN)
	Mellacarbon 125.Y Mellacarbon 250.Y Mellacarbon 350.Y Mellacarbon 500.Y	Carbon (CFC)
	Rombopak S4M Rombopak 9M Rombopak 6M Rombopak12M laboratory packing	Further types on request
	DX laboratory packing EX laboratory packing DXM, DYM laboratory packing made from sheet metal	CrNiMo steel Alloy C22 Carbon (CFC)
	Katapak-SP 11 Katapak-SP 12 Katapak-SP 13	Stainless steels Other steels available on request

	Applications	Diameter and operation range	Characteristics
	Basic chemicals and petrochemicals, ethylbenzene/styrene, fatty acids, tall oil, cyclohexanone/-ol, caprolactam, refinery operations, absorption/desorption columns, natural gas drying	From 80 mm up to 17 m (depending on type) Vacuum to high pressure Liquid load 0.2 to more than 200 m ³ /m ² h	Universal packing type, suitable for a wide range of applications Low to very high liquid loads
	Basic chemicals and petrochemicals, ethylbenzene/styrene, fatty acids, tall oil, cyclohexanone/-ol, caprolactam, refinery operations, absorption/desorption columns, natural gas drying	From 80 mm up to 12 m (depending on type) Vacuum to high pressure Liquid load 0.2 to more than 200 m ³ /m ² h	Universal packing type Boosts useful capacity
	Absorption/desorption columns	From 200 mm up to 15 m (depending on type) Vacuum to high pressure Temperature: PP max. 110°C, PVDF max. 150°C	Resistant to many chemicals Small pressure drop Separation efficiency similar to Mellapak made from metal
	Refineries and petrochemical industry Crude oil distillation Quench columns	Minimum diameter 900 mm Vacuum to high pressure	Robust construction Smooth surface No blockage, not sensitive to fouling Excellent flow stabiliser Efficient de-entrainment device
	Fine chemicals Isomers Fragrances Flavours Low liquid loads with aqueous solutions	From 40 mm up to 6 m (depending on type) Pressure 1 mbar to atmospheric pressure, optimum: 1-100 mbar From 100 mm up to 4 m (depending on material) Pressure 1 mbar to moderate pressure Temperature max. 80°C	High separation efficiency, even at small liquid loads Low pressure drop, Small hold-up BXPlus: Same efficiency as BX, lower pressure drop Self-wetting, even with aqueous solutions Large number of transfer units per meter, even with small liquid loads Low pressure drop
	Hydrofluoric acid, carboxylic acid, caustic solutions	From 30 mm Vacuum to moderate pressure Temperatures up to more than 400°C	High separation performance Best chemical resistance and thermal stability Low pressure drop
	Pharmaceutical and fine chemicals Alcohols, esters, fatty acids and derivatives Fragrances and flavours Solvent recovery Fouling services Pilot plants	From 28 mm up to 4 m Vacuum to moderate pressure	Grid structure: Surface divided in a large number of streamlined lamellas Unique distribution effect for the liquid and good distribution of vapor flow Constant separation performance independent of vapor load
	Laboratory and pilot columns	DX, DXM, DYM 30-125 mm, EX 20-85 mm Vacuum to atmospheric pressure	Smallest hydraulic diameter EX, DX: Very high number of theoretical stages per meter, low pressure drop DXM, DYM: Constant HETP over the whole F factor range
	Acetates, methyl acetate hydrolysis, fatty acid esters Acetals MTBE, ETBE, TAME	From 50 mm Vacuum to moderate pressure	Packing for reactive distillation and trickle-bed reactors High separation efficiency and high reaction capacity Modular concept

Laboratory packing

Highest number of theoretical stages per unit height



0691 2532-2

Standard structured packings are hardly suitable for use in laboratory columns of less than 50 mm diameter. Sulzer laboratory packings are especially designed for this purpose.

Preferred applications:

- Laboratory columns from 20 to 80 mm
- Vacuum from 1 mbar
- Where a high number of theoretical stages is required (DX, EX)
- Distillation of components prone to decomposition
- Preliminary assessment of a separation task
- Deriving of reliable scale-up rules

Special features:

Small pressure drop

Type EX:

- Highest possible number of theoretical stages, even with very low liquid loadings
- Same pressure drop per theoretical stage as Sulzer BX packing
- Small hold-up
- Capacity nearly double that of wire mesh rings (3 x 3 mm)

Type DX:

This packing has a coarser structure and hence a lower number of theoretical stages.

Suitable for laboratory columns where a modest number of theoretical stages is required, together with low pressure drop and high capacity.

Type DXM/DYM:

These packing types, made of sheet metal, have a lower number of theoretical stages compared to DX. HETP or NTSM remain constant over a wide range of F factors and liquid loads. This makes scale-up significantly easier.

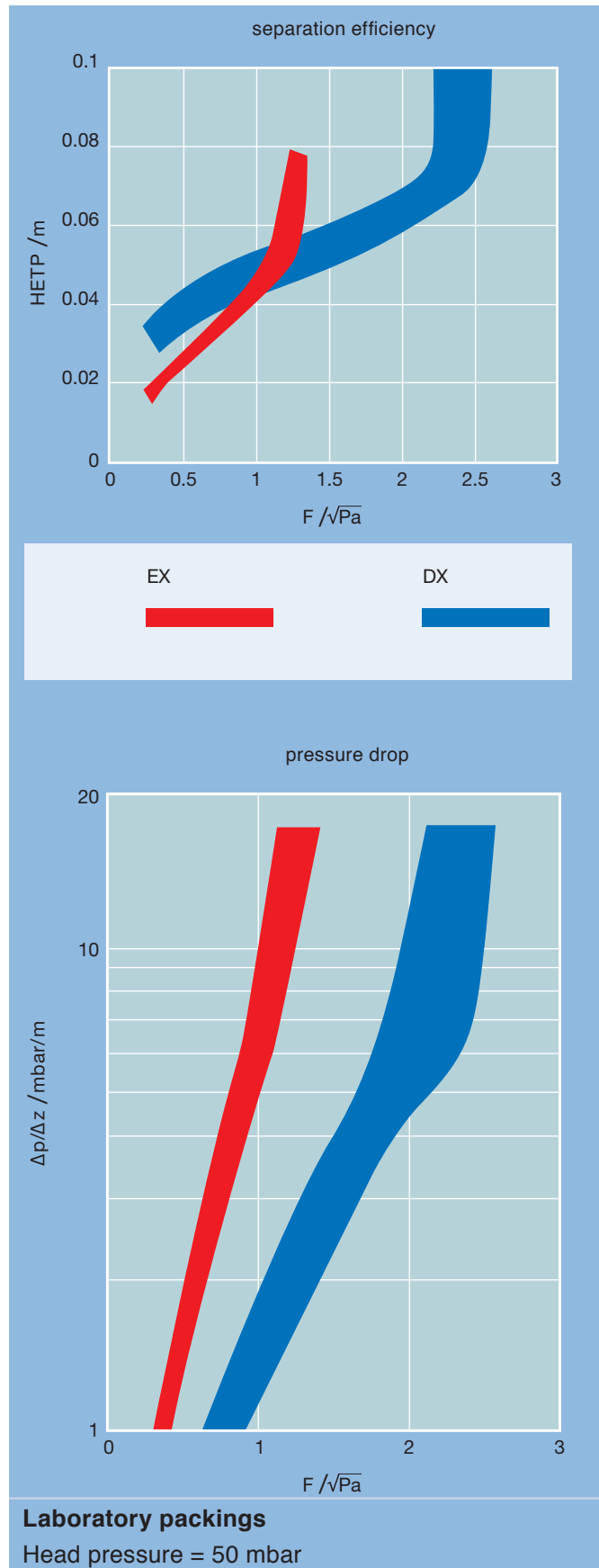

Rombopak

The packing with the unique structure and performance

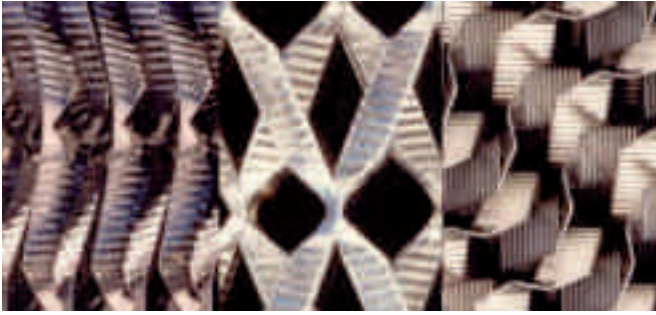

The unique open structure has been specifically developed for the ambitious distillation requirements of the fine chemical industry. It has been widely used in the most diverse applications and has become a well established preferred choice of the pharmaceutical industry and specialty chemistry.

Special features

- Grid structure: Surface divided in a large number of streamlined lamellas
- Unique distribution effect for the liquid and good distribution of vapor flow
- Maximized open area for the vapor to flow through resulting in a reduced pressure drop
- Constant separation performance independent of vapor load
- Pilot size diameters available down to 28 mm

Preferred applications

- High capacity and separation performance at minimum pressure drop
- Ideal for miniplant applications due to its exceptional scale-up properties. Easy validation in GMP regulated processes
- Highly resistant against fouling due its open structure
- Good performance with viscous liquids

Typical product applications

- Pharmaceutical and fine chemicals
- Alcohols, esters, fatty acids and derivatives
- Fragrances and flavours
- Solvent recovery
- Fouling services
- Pilot plants

Rombopak types

Rombopak	S4M	6M	9M	12M
NTSM	2.4	3.7	6.0	8.0

Rombopak 12M only for lab or pilot plant up to 150 mm diameter.

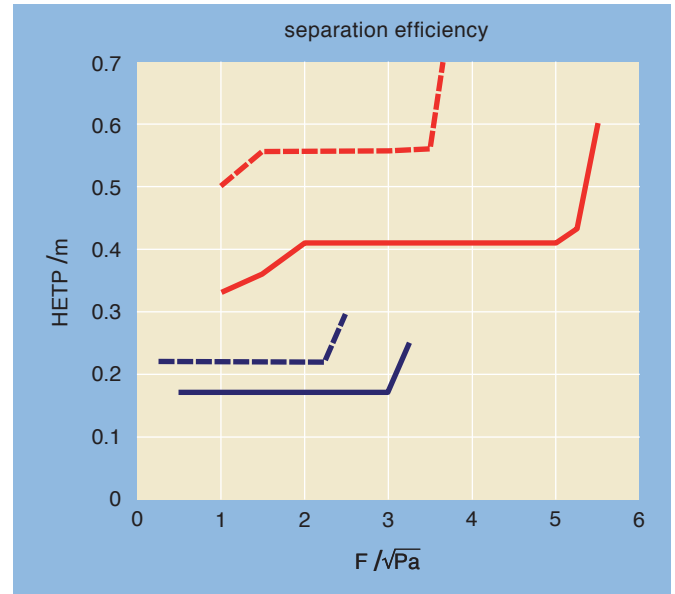

Rombopak R9M

Rombopak R4M

67 ———

67 ———

960 - - - - -

960 - - - - -

parameter = head pressure p /mbar

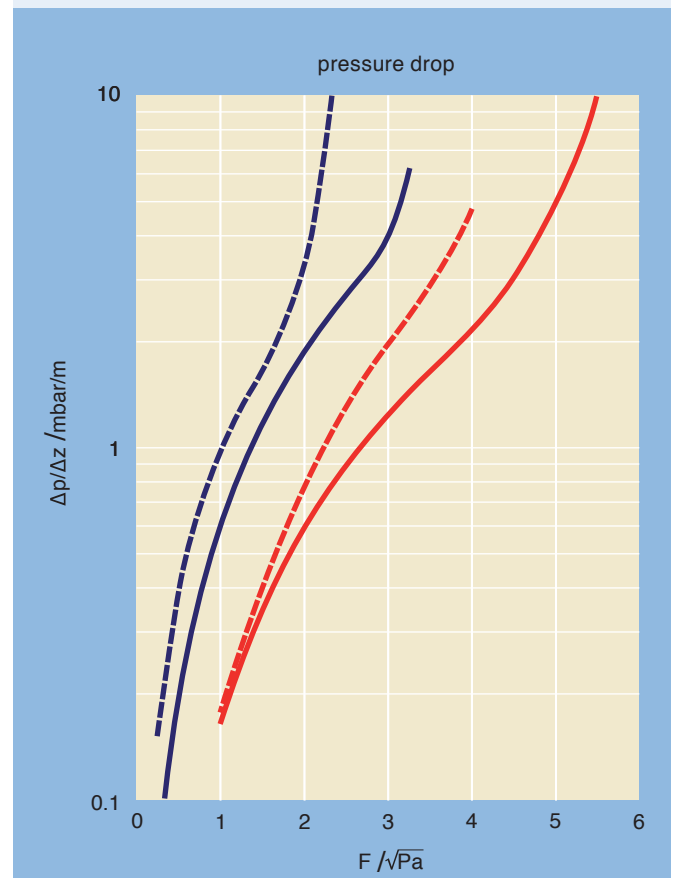

Rombopak

Mellapak 250.Y/X

A highly versatile packing type



0602 2510

Mellapak is the most widely used structured packing worldwide. It has proven excellent performance in columns with diameters up to 15m. It is supplied in sheet metal thicknesses from 0.1 mm up.

Special features

- Pressure drop per theoretical stage 0.3-1.0 mbar
- Pressure drop at 70-80% flooding about 2 mbar/m
- Minimum liquid load approx. $0.2 \text{ m}^3/\text{m}^2\text{h}$
- Maximum liquid load up to more than $200 \text{ m}^3/\text{m}^2\text{h}$ (typically in desorption columns)

Preferred applications

- Vacuum to moderate pressure
- High pressure in selected applications
- Increasing capacity of existing tray and packed columns

Typical applications

- Chemical industry: Ethylbenzene/styrene, tall oil, cyclohexanone/-ol, air separation
- Petrochemical industry: Quench columns, C_3 - and C_4 - splitters, xylene splitters
- Refineries: Vacuum and atmospheric columns
- Absorption: Natural gas drying, CO_2 - and H_2S -absorbers and strippers, ethyleneoxide absorbers and strippers, acrylonitrile absorbers

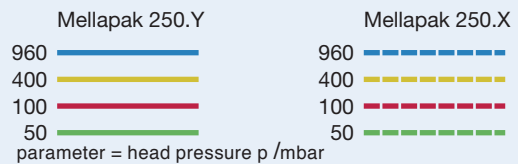
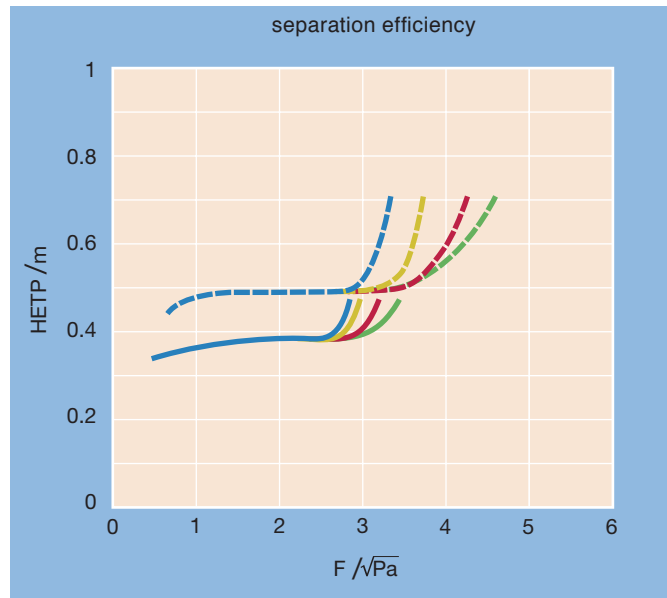

Mellapak 250.Y
Mellapak 250.X

Mellapak

A solution available for any application

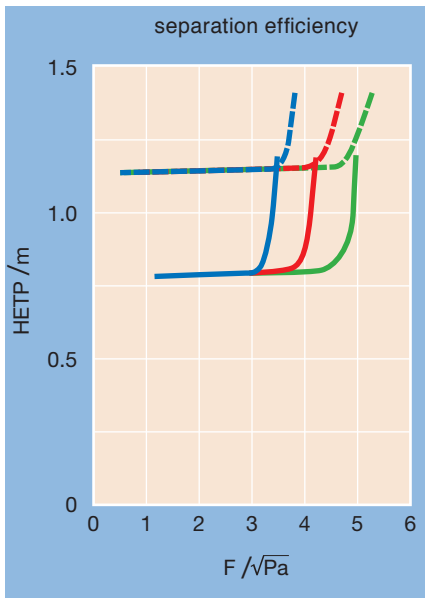

Mellapak 125.Y Mellapak 125.X
 960 ——— 960 - - - -
 100 ——— 100 - - - -
 50 ——— 50 - - - -
 parameter = head pressure p /mbar

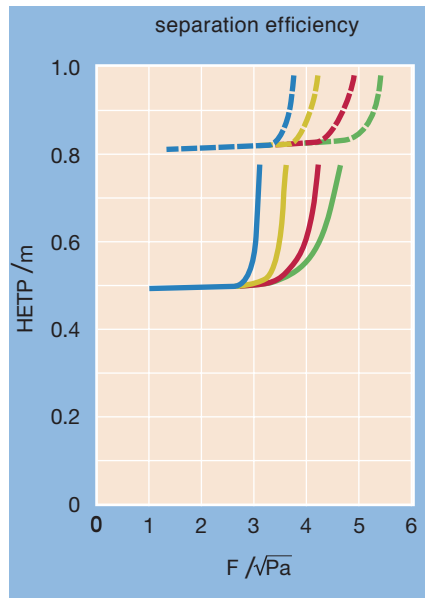

Mellapak 170.Y Mellapak 170.X
 960 ——— 960 - - - -
 400 ——— 400 - - - -
 100 ——— 100 - - - -
 50 ——— 50 - - - -
 parameter = head pressure p /mbar

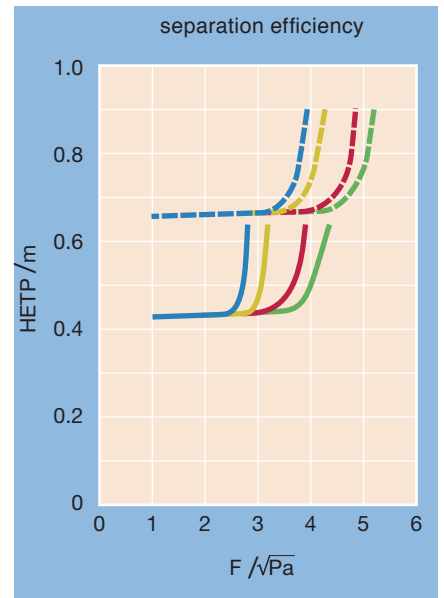

Mellapak 2Y Mellapak 2X
 960 ——— 960 - - - -
 400 ——— 400 - - - -
 100 ——— 100 - - - -
 50 ——— 50 - - - -
 parameter = head pressure p /mbar

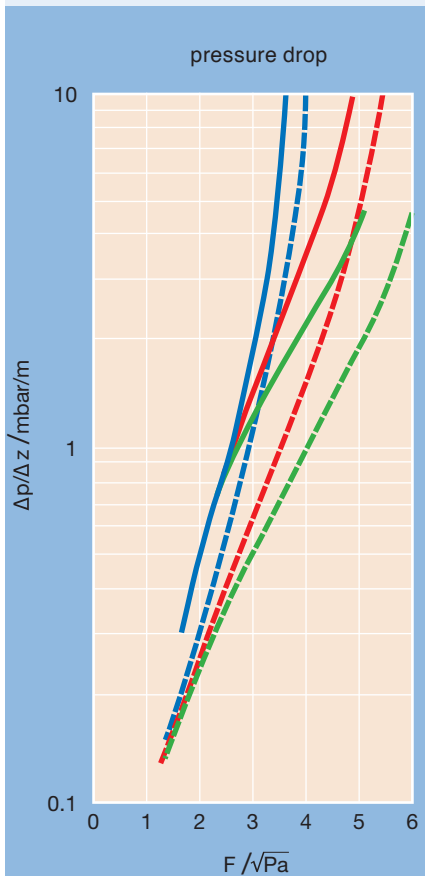

Mellapak 125.Y
Mellapak 125.X

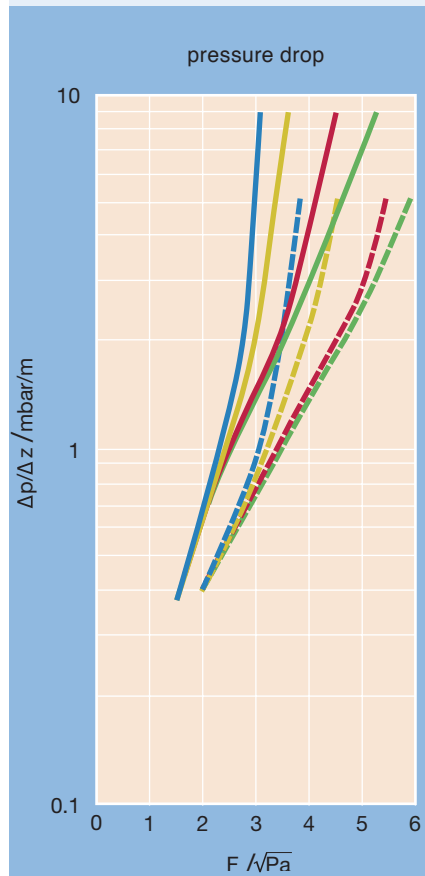

Mellapak 170.Y
Mellapak 170.X

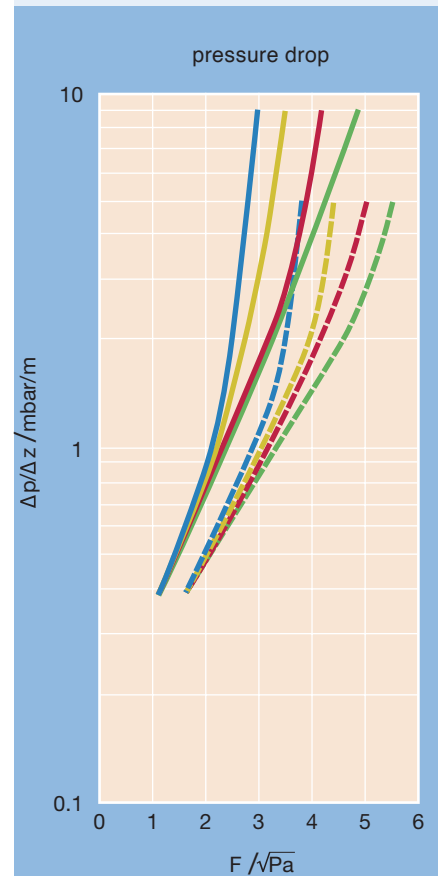

Mellapak 2Y
Mellapak 2X

Mellapak

A solution available for any application

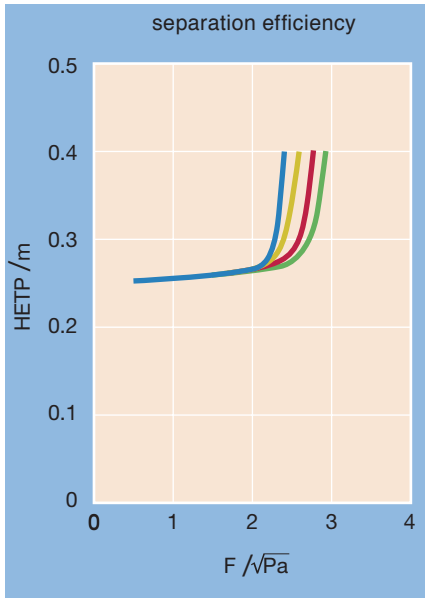

Mellapak 350.Y

960

400

100

50

parameter = head pressure p /mbar

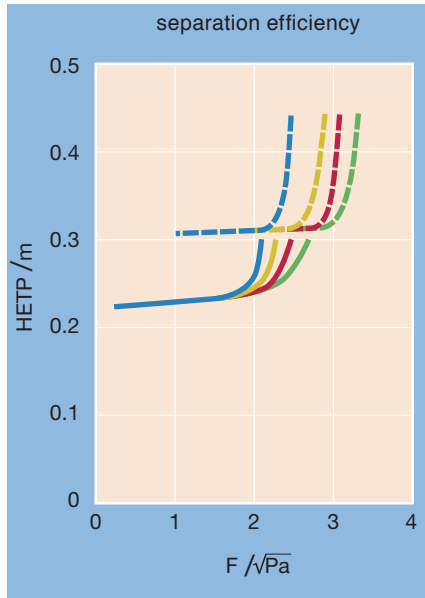

Mellapak 500.Y

960

400

100

50

parameter = head pressure p /mbar

Mellapak 500.X

960

400

100

50

parameter = head pressure p /mbar

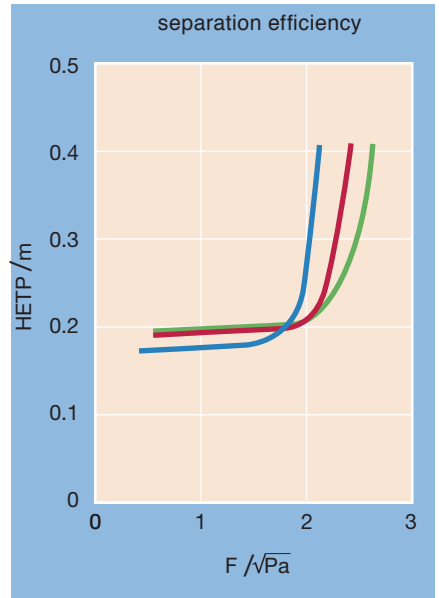

Mellapak 750.Y

960

100

50

parameter = head pressure p /mbar

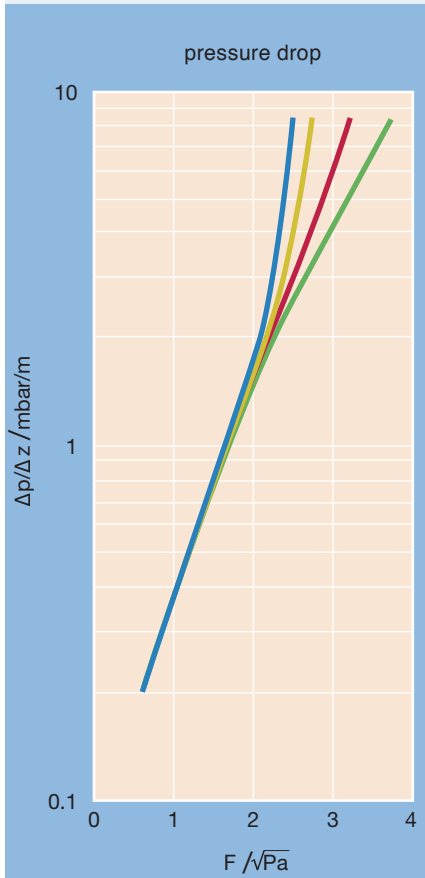

Mellapak 350.Y

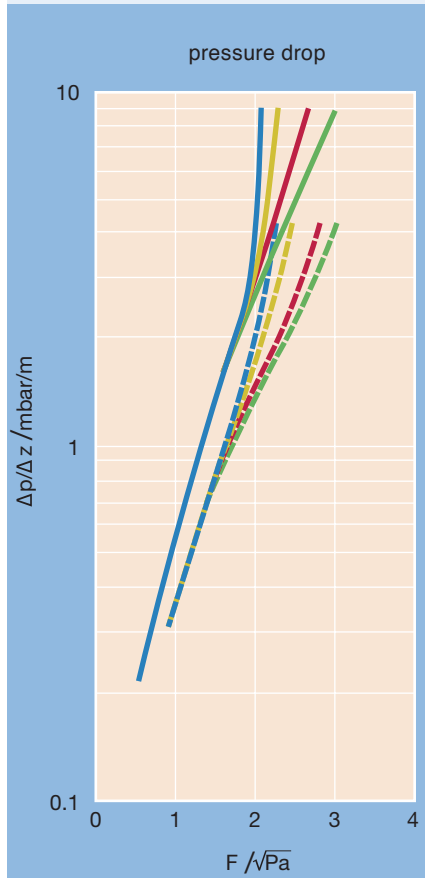

Mellapak 500.Y

Mellapak 500.X

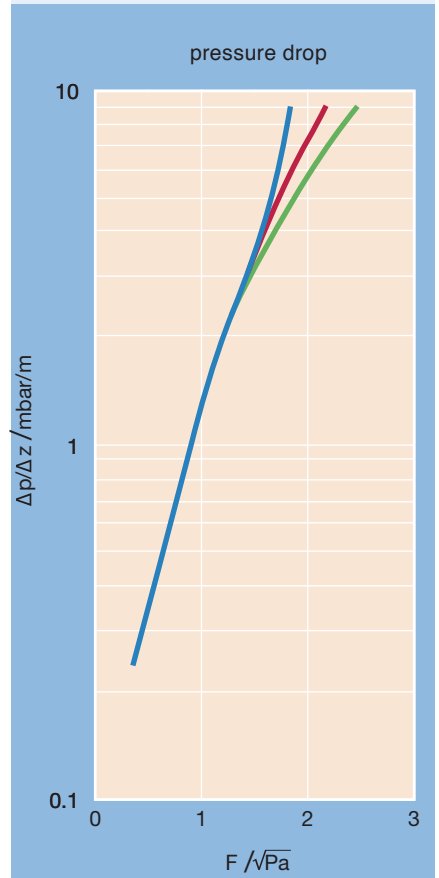

Mellapak 750.Y

MellapakPlus

A new generation of structured packings

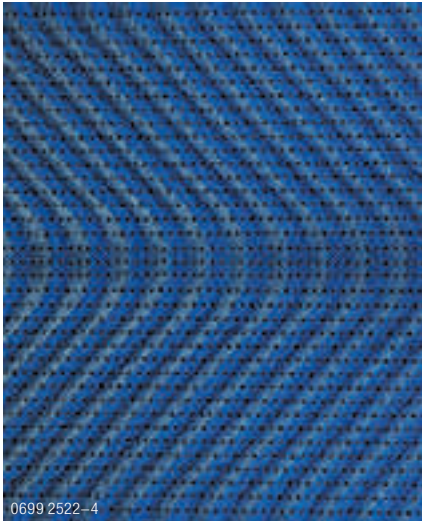

MellapakPlus is a capacity enhanced structured packing. It combines all advantages of the metal sheet packing Mellapak with new geometrical features.

Features of MellapakPlus

At the lower and upper end of each packing element, the orientation of the corrugation gradually approaches the vertical axis. Advantages of this geometrical modification:

- The vapor flow smoothly changes direction at the interface between two packing elements
- At the interface vapor flow is nearly parallel to the vertical axis of the column. The gas velocity is therefore reduced by about 25% compared to the velocity inside the packing element

Both factors reduce the pressure drop and the shear forces, which are especially critical at the interface due to the presence of thicker and less stable liquid films. As a result, premature flooding at the interface is no longer of concern.

In the interior part of the packing element the geometrical features of MellapakPlus and Mellapak are identical. Hence, separation efficiency is similar – but with a significant increase in capacity and a reduction in pressure drop. All other MellapakPlus properties – including installation procedure, mechanical strength and corrosion resistance – are identical to Mellapak.

MellapakPlus performance has been confirmed in category 1 tests at F.R.I.

Internals

The close resemblance between MellapakPlus and Mellapak guarantees continued use of the whole range of well known and reliable internals. Internals are now able to handle the increased gas load typical for the high capacity of MellapakPlus. Sulzer Chemtech is committed to the on-going, focused development of novel designs.

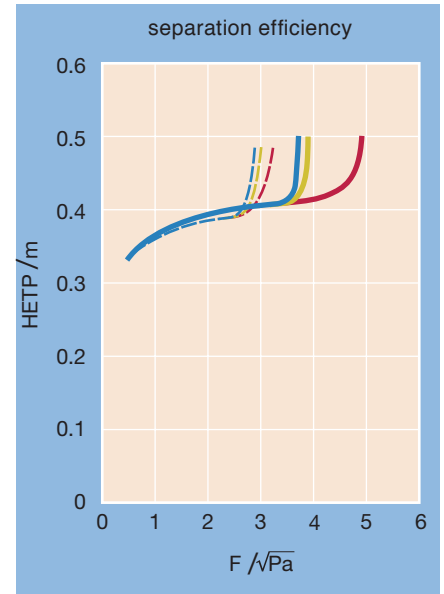

MellapakPlus 252.Y	Mellapak 250.Y
960 ———	960 - - - -
400 ———	400 - - - -
100 ———	100 - - - -

parameter = head pressure p / mbar

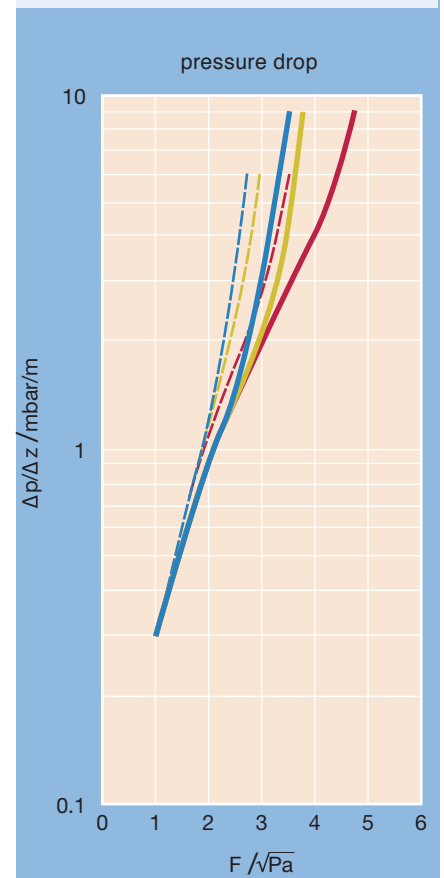

MellapakPlus 252.Y vs. Mellapak 250.Y

MellapakPlus

A new generation of structured packings

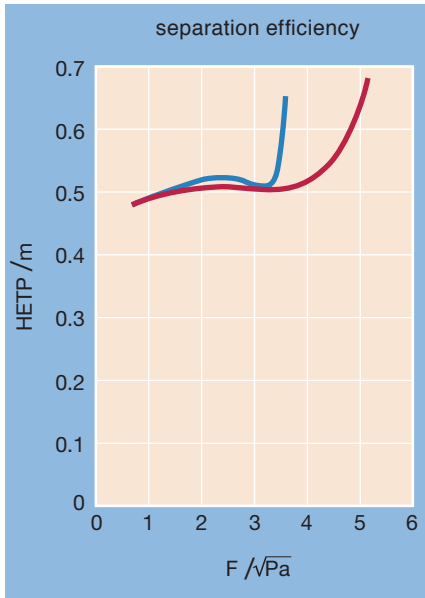

MellapakPlus 202.Y

960 ———

100 ———

parameter = head pressure p /mbar

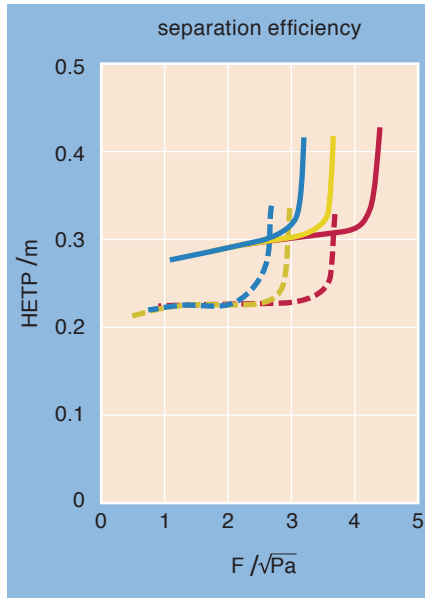

MellapakPlus 352.Y MellapakPlus 602.Y

960 ——— 960 - - - -

400 ——— 400 - - - -

100 ——— 100 - - - -

parameter = head pressure p /mbar

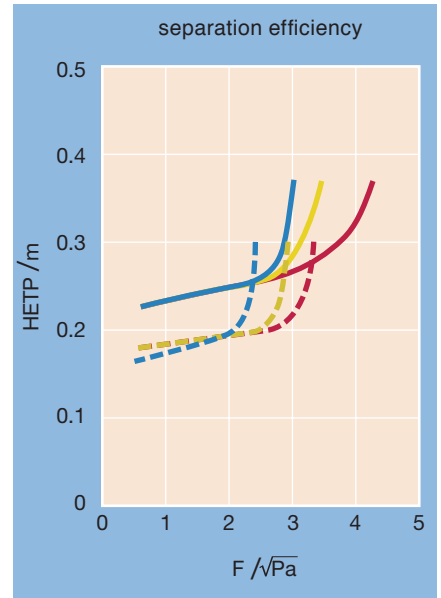

MellapakPlus 452.Y MellapakPlus 752.Y

960 ——— 960 - - - -

400 ——— 400 - - - -

100 ——— 100 - - - -

parameter = head pressure p /mbar

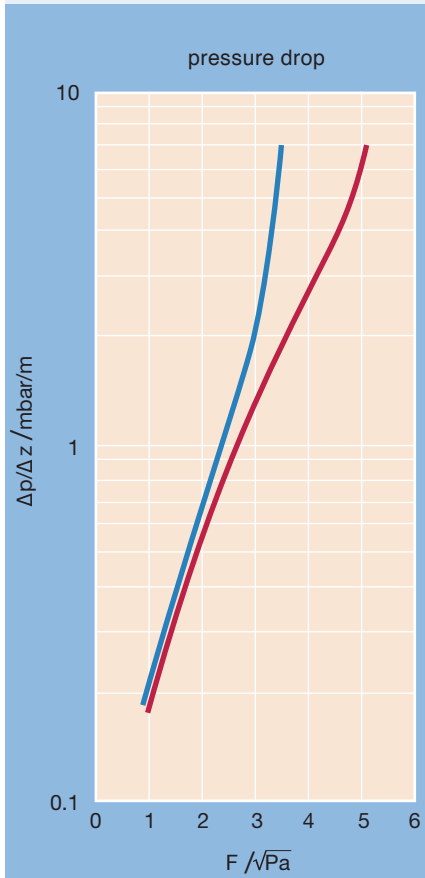

MellapakPlus 202.Y

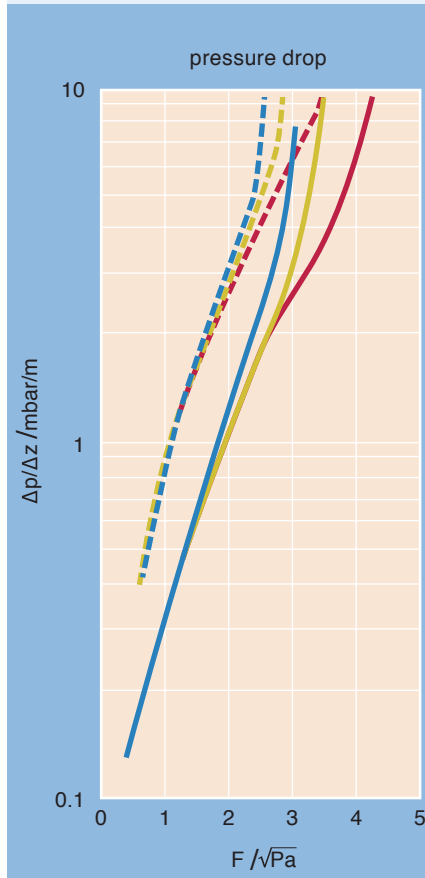

MellapakPlus 352.Y
MellapakPlus 602.Y

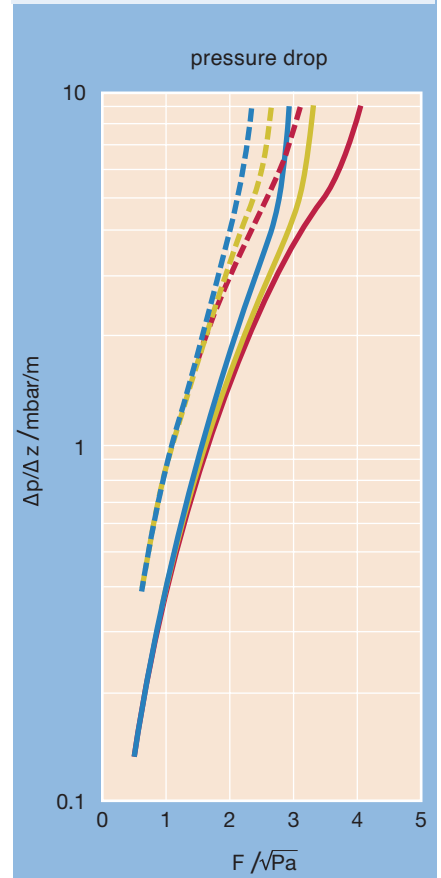

MellapakPlus 452.Y
MellapakPlus 752.Y

Gauze packings

Sulzer metal gauze packing, type BX and BXPlus



0682 2017

This packing has been successfully employed in the industry for over 40 years. Largest diameter supplied to date: 6 m.

Special features

- High number of theoretical stages per unit height
- Pressure drop per theoretical stage 0.1 – 0.5 mbar
- Most economical load range:
F factor 1-2.5 \sqrt{Pa}
- Minimum liquid load approx. 0.05 m³/m²h
- Small hold-up

Preferred applications

- Large number of theoretical stages
 - Vacuum from 1 mbar to atmospheric pressure
 - Where minimum pressure drop per theoretical stage is important
 - Small overall height
 - Batch and continuous columns
 - Pilot columns (reliable scale-up)
- Limited suitability for
- Fouling substances
 - Non-wetting liquids

Product applications

- Monomers from plastics (MDI, DMT, etc.)
- Fatty acids, fatty alcohols, fatty acid esters
- Mono-, di-, tri-, and tetraethylene glycols
- Fine chemicals

BXPlus

BXPlus is a further development of the well proven gauze packing BX. Its geometry is similar to MellapakPlus. BXPlus offers the same efficiency as BX with a 20% lower pressure drop. It is recommended for gentle distillation at higher capacity.

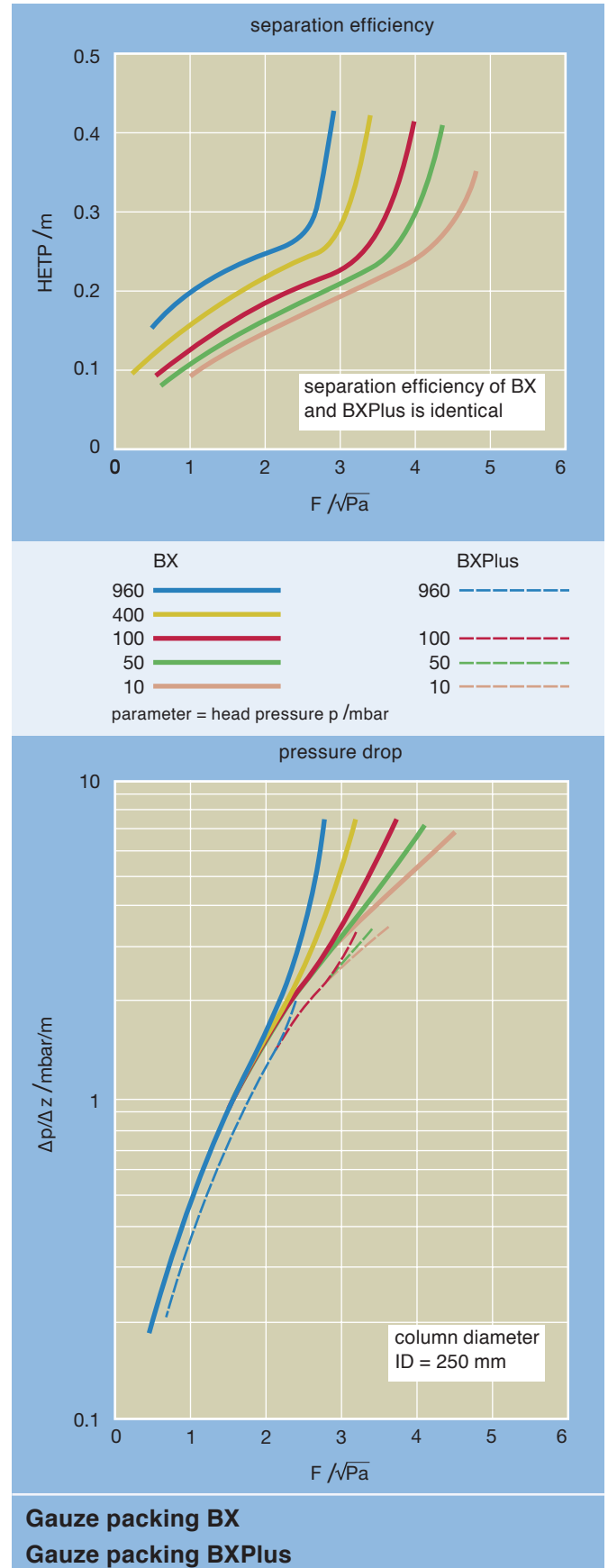

Gauze packings

Sulzer metal gauze packing, type CY



4588 3043

This packing was developed for separations that require a large number of theoretical stages. Largest diameter supplied to date: 1.8 m.

Special features

- Maximum number of theoretical stages per meter
- Most economical load range:
F factor $1.5 - 2 \sqrt{Pa}$
- Minimum liquid load approx. $0.05 \text{ m}^3/\text{m}^2\text{h}$
- Small hold-up

Preferred applications

- For a very large number of theoretical stages
- Vacuum from 1 mbar to atmospheric pressure
- Small overall height
- Batch and continuous columns
- Pilot and laboratory columns (reliable scale up)

Limited suitability for

- Fouling substances
- Non-wetting liquids

Product applications

- Pharmaceutical products (vitamins, etc.)
- Fragrances (menthol, geraniol, etc.)
- Separation of isomers

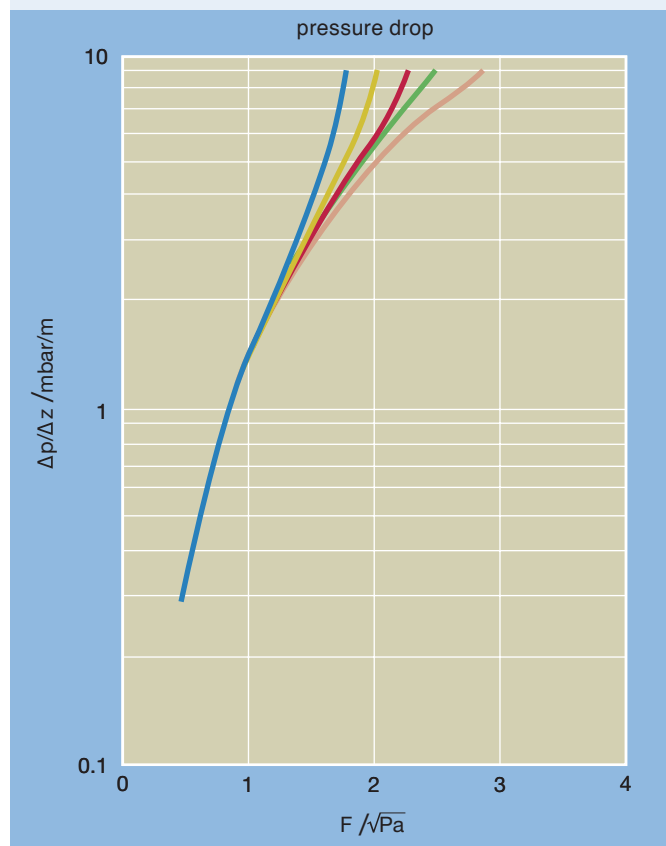
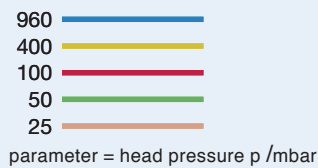
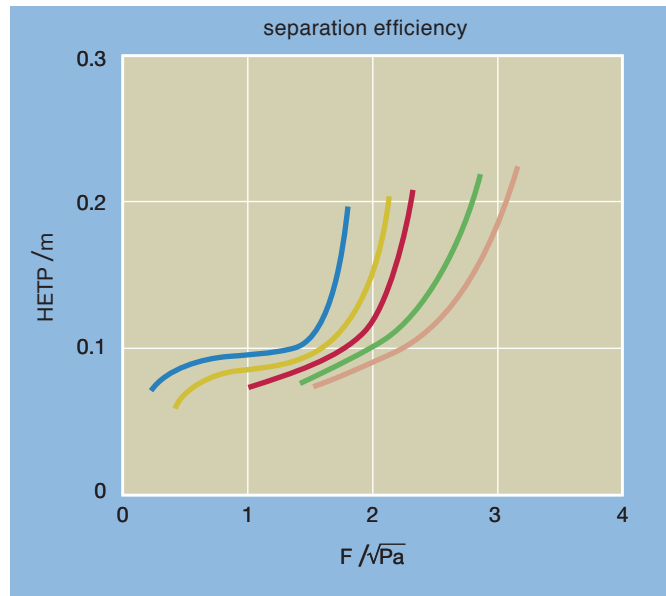

Gauze packing CY

Mellapak and MellapakPlus from plastics



0682 2021

The MELLAPAK 125.X, 125.Y, 250.X and 250.Y and MellapakPlus 252.Y are also available in different kinds of thermoplastics. Packings made of polypropylene (PP), postchlorated polyvinylchloride (PVC-C), polyvinylidene-difluoride (PVDF), Teflon® PFA and polyether ether ketone (PEEK) can be supplied.

The plastic versions of MELLAPAK have proven operational record in various types of absorption and desorption columns.

Special features

- Large number of transfer units per meter, low HTU, depending on the system
- Small pressure drop per meter packed height
- Most economical load range up to F factor $4\sqrt{\text{Pa}}$
- Maximum operating temperatures:
approx. 110°C for polypropylene
approx. 150°C for PVDF

Product applications

- HCl absorbers
- SO₂ absorbers
- Flue gas cleaning columns
- Sea water deaerators

MellapakPlus 252.Y has the same efficiency as Mellapak 250.Y and same capacity as Mellapak 250.X

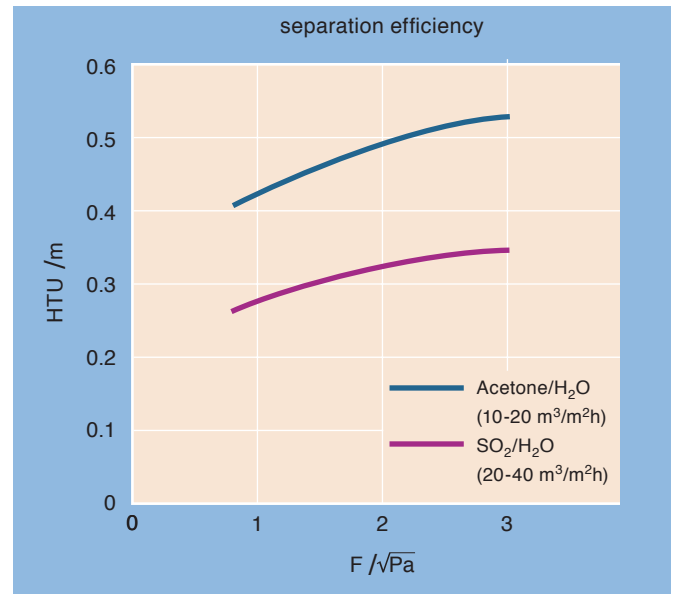

Separation efficiency of Mellapak 250.Y PP

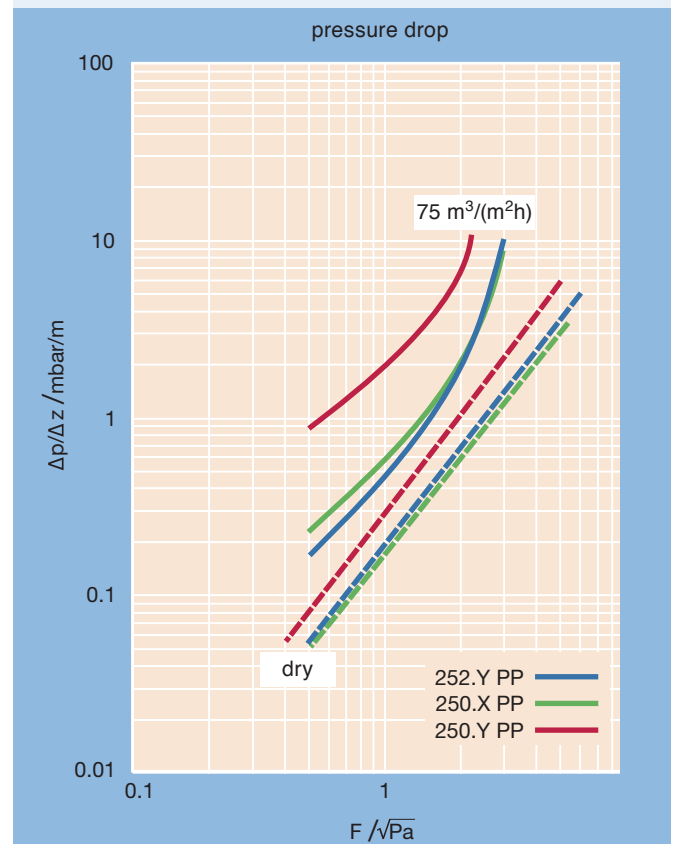

Mellapak PP
atmospheric pressure

Gauze packings

Sulzer plastic gauze packing, type BX



0682 2020

The plastic gauze packing has been used industrially with great success for many years. The special gauze structure provides a very good wettability, even in aqueous systems. This packing is used primarily for columns with low liquid loads.

Special features

- Large number of transfer units per meter, low HTU, depending on the system
- Minimum pressure drop, typically 2–4 mbar/m
- Minimum liquid load approx. $0.05 \text{ m}^3/\text{m}^2 \text{ h}$
- Self-wetting packing surface, even for aqueous solutions
- Operating temperatures up to 80°C , depending on the chemical components

Preferred applications

- Small liquid loads
- Increasing performance of existing columns
- Columns with small overall height

Product applications

- Methanol absorbers
- Isopropanol absorbers
- Dimethylformamide absorbers
- Formaldehyde absorbers

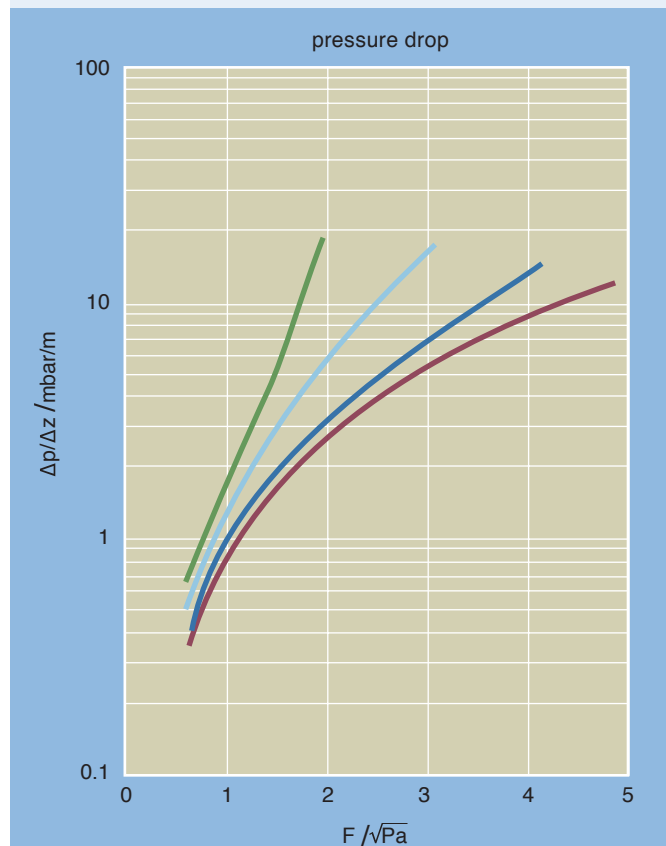
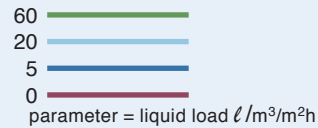
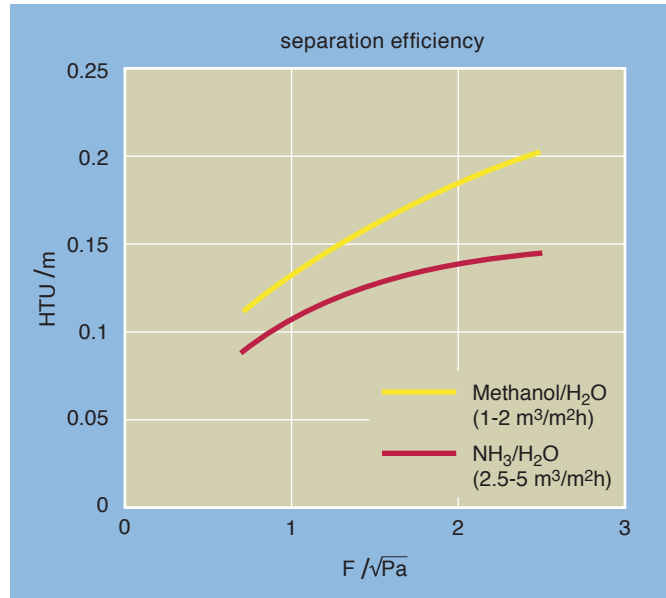

Plastic gauze packing BX

atmospheric pressure, ID = 300 mm

Mellacarbon – pure carbon



0697 2522

Carbon does not react with most solvents, acids or lyes. Sulzer Chemtech offers various Mellacarbon types.

- Corrosion-proof against caustic solutions, non-oxidizing inorganic acids including hydrofluoric acid and carboxylic acids
- Excellent wettability, also in aqueous systems
- Specific surface area of 125–1700 m²/m³
- High thermal stability (> 400°C)

Product applications

- HCl separation for production and for HCl recovery (typically in the production of polycarbonate)
- MCA/DCA distillation
- Production of phosphoric acid
- Concentration of hydrofluoric acid
- Separation of chlorophenols

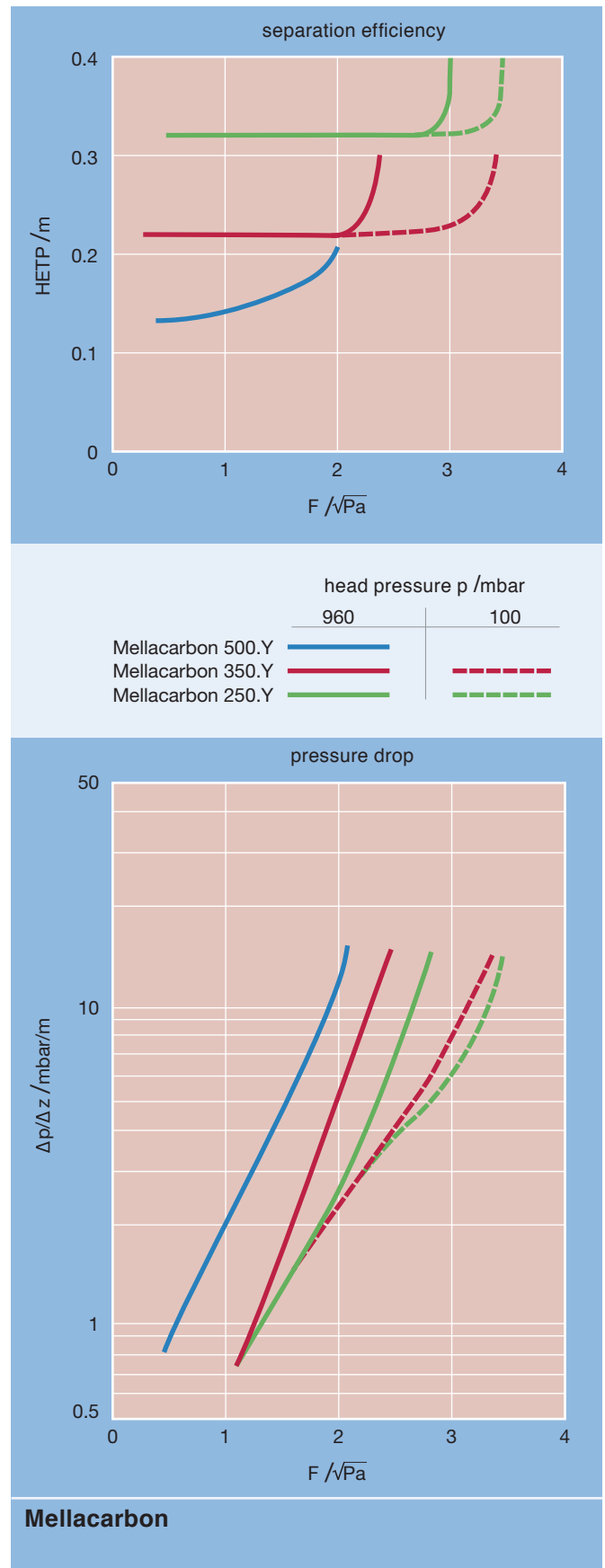

Mellagrid

Sulzer structured grid packings

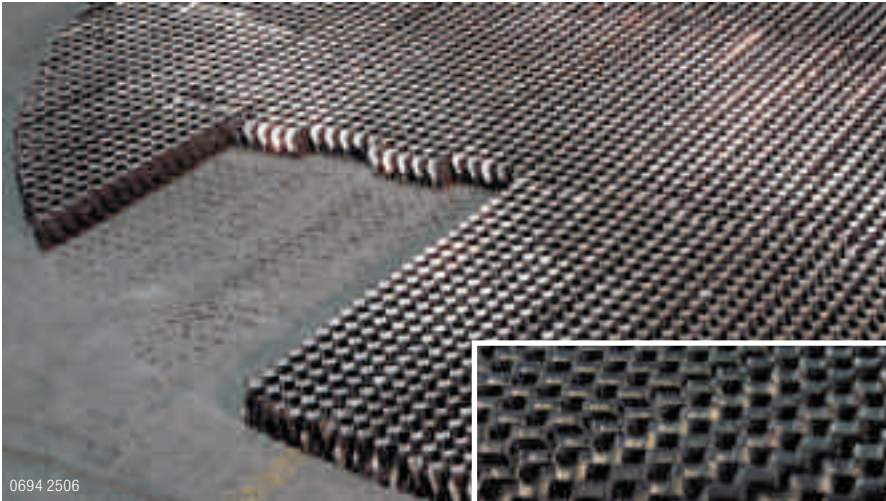

With Mellagrid, Sulzer Chemtech combines the efficiency of structured packings with the mechanical resistance of a grid. Mellagrid is used wherever the mechanical strength of structured packings is a concern or where coking is likely to occur.



Technical Data

Mellagrid	90.X	64.X	64.Y	40.Y
Specific surface area	90 m ² /m ³	64 m ² /m ³	64 m ² /m ³	40 m ² /m ³
Element height (approx.)	140 mm	220 mm	130 mm	200 mm
Surface structure	smooth			
Material thickness	0.5 to 2 mm			
Material	AISI 410S or 316L, other materials upon request			

Special features

- Not sensitive to coking and fouling due to its smooth surface and geometrical structure
- Efficient dissipation of temperature
- Better de-entrainment and separation efficiency than a traditional grid
- The low element height and its structure allow for easy cleaning. It can be removed, unscrewed and cleaned with a water jet
- Mechanically robust structure

Applications

- Atmospheric or vacuum tower: Wash section
- FCC Main Fractionator: Slurry pumparound section
- Coker or Visbreaker Fractionator: Wash section

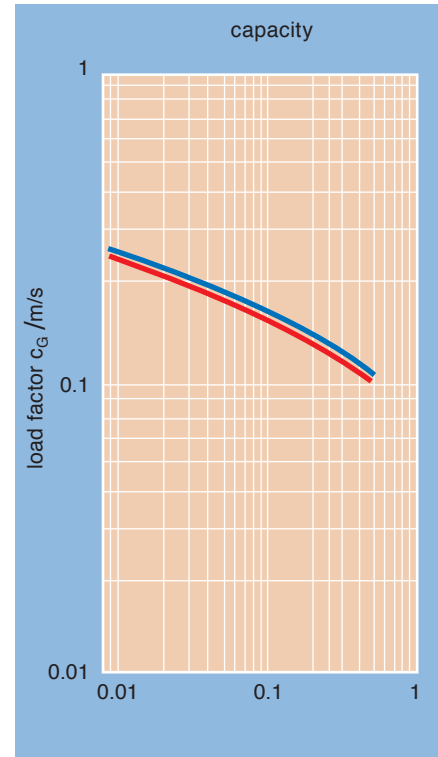

40.Y 64.X
64.Y 90.X

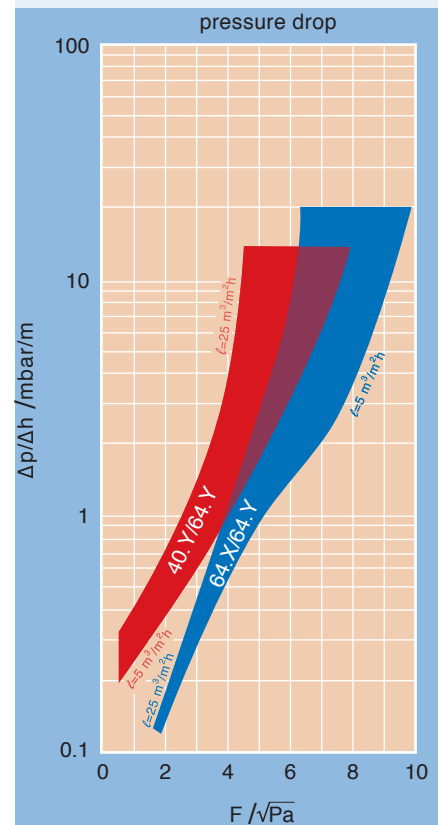

Mellagrid

various liquid loads, air/water,
T=30 °C, atmospheric pressure

Katapak-SP

Sulzer reactive distillation packing

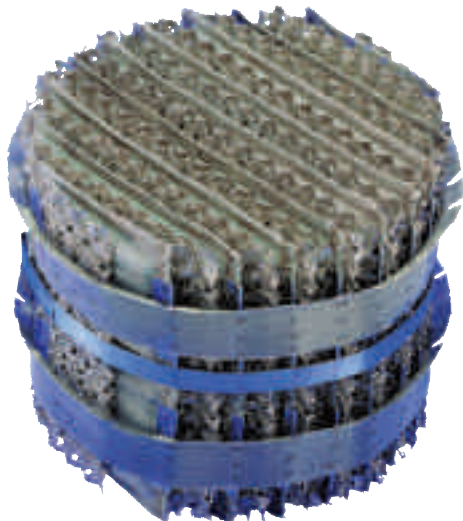

0600 2701-6

This packing was developed to be applied in reactive distillation processes. With the modular concept separation efficiency and catalyst volume fraction can be varied to perfectly fit the requirements of each specific process. Other types are available on request. Largest diameter supplied to date: 2 m.

Special features:

- Flexible design combining catalyst elements and MellapakPlus layers
- High separation efficiency
- High reaction capacity

Product applications:

- Synthesis of acetates (e.g. butyl acetate)
- Hydrolysis of methyl acetate
- Synthesis of fatty acid esters
- Synthesis of acetals
- MTBE, ETBE, TAME

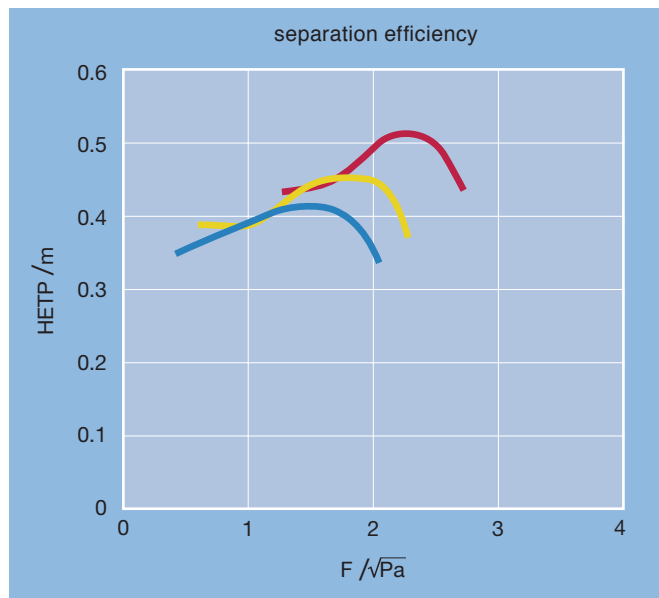

Katapak-SP 12

960 ———

400 ———

100 ———

parameter = head pressure p /mbar

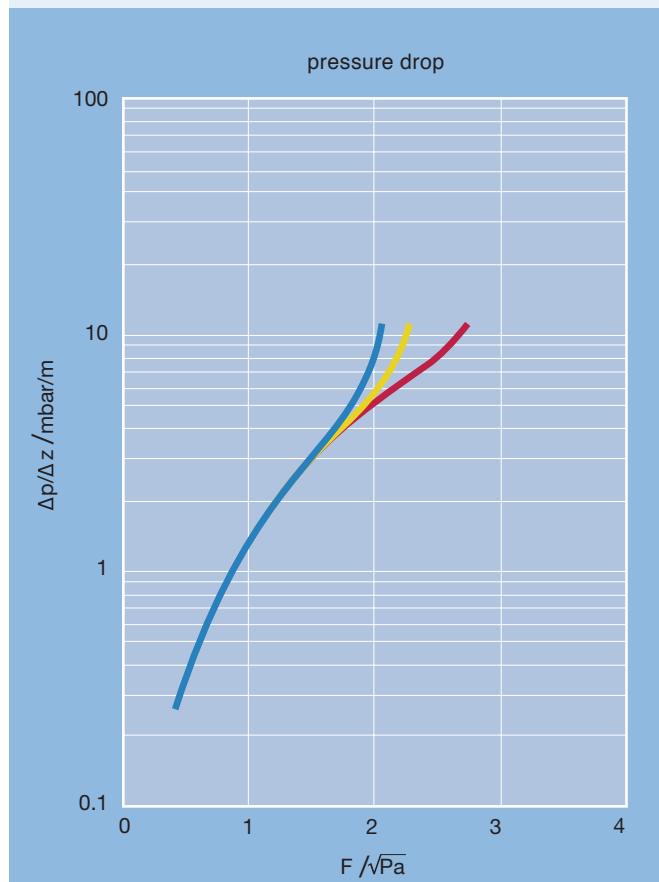

Katapak

Column internals

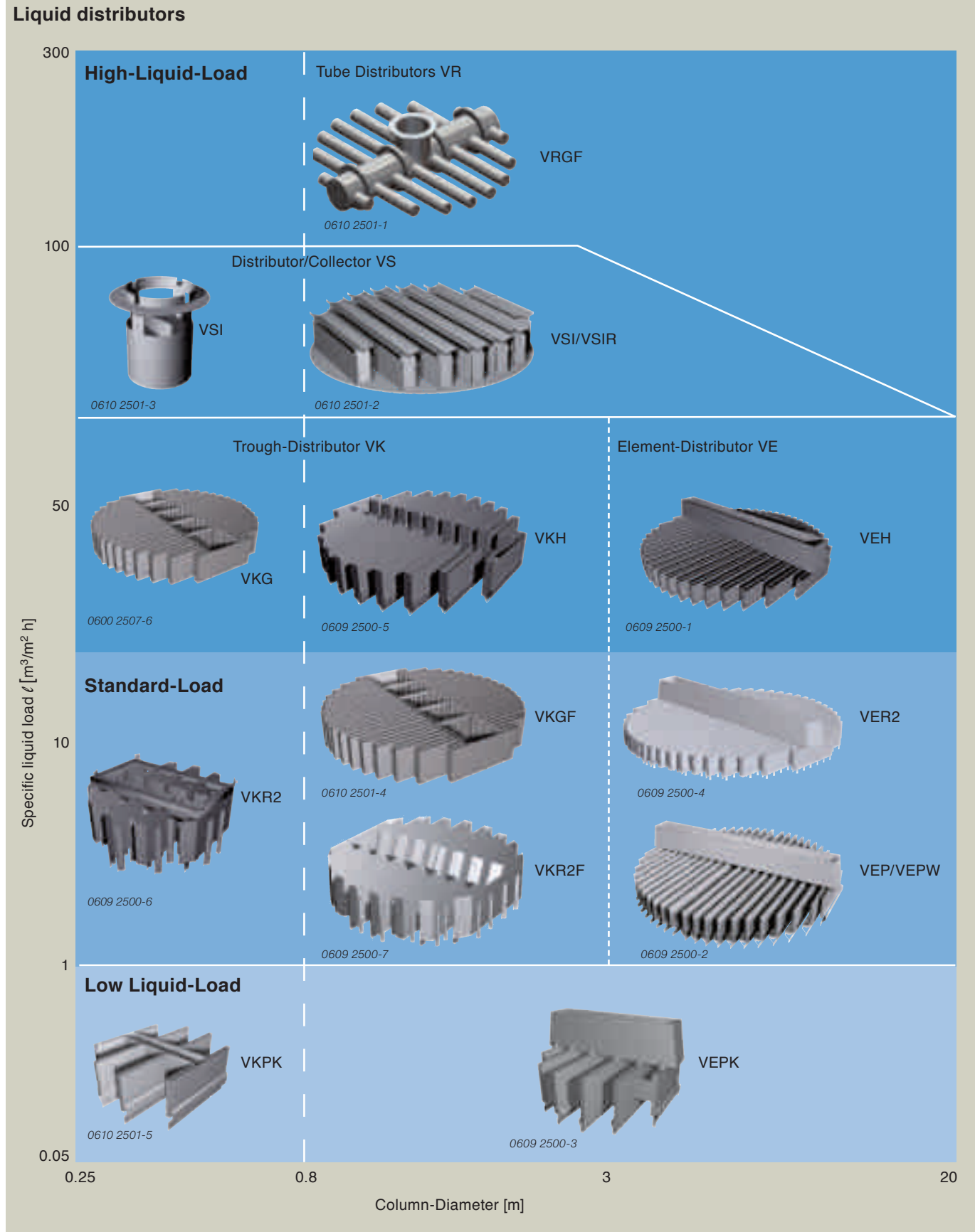

Column internals

Collector support grids

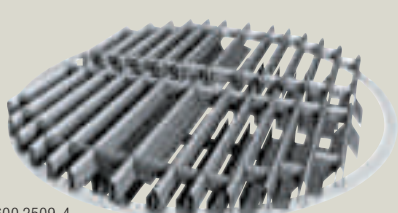
	Type	Column diameter	Features
 <p>0600 2509-4</p>	SLRT/SLMT	from 0.3 m	<p>The collector SLT is both a packing support and a vane collector. As a packing support, it can support the direct load of packings with surface areas up to 350 m²/m³. For finer packings, additional drip plates are used.</p> <p>This non-welded collector SLT is often used in applications where space between packed beds is limited. This collector requires a support ring inside the column.</p>

Collectors

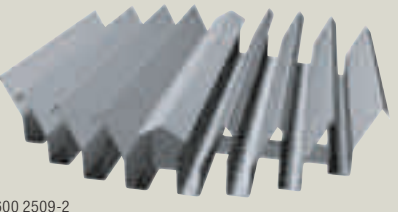
 <p>0600 2509-2</p>	SLR/SLM	from 0.3 m	<p>The vane collector SL is used as a separate unit to accumulate liquids from packed sections within a column. This collector requires a ring channel welded to the column wall.</p> <p>The collector SLF is designed to be installed between the column flanges in smaller flanged columns.</p>
--	---------	------------	---

Chimney trays

 <p>0600 2506-1</p>	SK	from 1 m	<p>The collector SK is an established and versatile tray design, available either in bolted or seal-welded construction. It is generally used in large diameter columns with high liquid loads.</p>
--	----	----------	---

Column internals

Collector-distributor systems/Vapor distributor

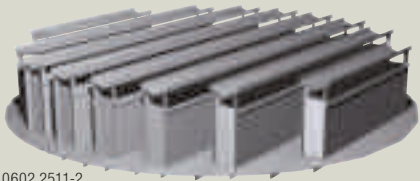
	Type	Column diameter	
 <p>0602 2511-2</p>	VSI	from 0.25 m	<p>The collector/distributor VS is used whenever collection and redistribution of liquid is required at very high liquid loads. It resembles a chimney tray; however the chimney arrangement is custom designed for your application's liquid distribution and pressure drop requirements.</p> <p>For moderate liquid loads applications, where liquid mixing is important, a separate accumulator tray must collect the liquid and feed it to a liquid distributor located below it.</p>

In addition, special collector-distribution systems are available, e.g. for use at increased pressures or - in conjunction with highly corrosion-resistant packings - in processes with aggressive media. Supplementary information is to be found in our brochure "Internals for Packed Columns".

Support grids

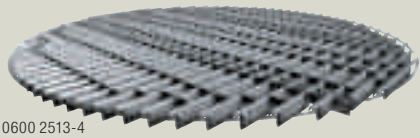
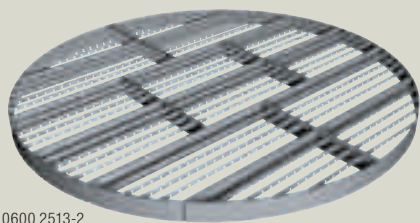
 <p>0600 2513-4</p>	TEB/TSB	0.5 to 10 m	<p>TEB and TSB are used with structured packings. Both require support rings to be welded to the column wall. TEB are supports for flanged columns. The segmental grids of the TSB pass through manholes and are clamped together for convenient installation. No welding is required.</p> <p>TEB and TSB support grids are ideal for applications requiring expensive high-alloys. Certain high performance packings require additional drip plates.</p>
 <p>0600 2513-2</p>	TS/TE	from 0.1 m	<p>TE and TS are intended for structured packings with surface area over 350 m²/m³ packing volume. They are designed with drip plates to prevent premature flooding of the packing.</p> <p>These support grids rest on support rings or gussets welded to the column shell. For columns over 3 m, additional supports and major beams may be required.</p>

Revamping of existing columns

Repacking the entire column cross-section

Along with other aspects, this modification serves to increase the throughput.

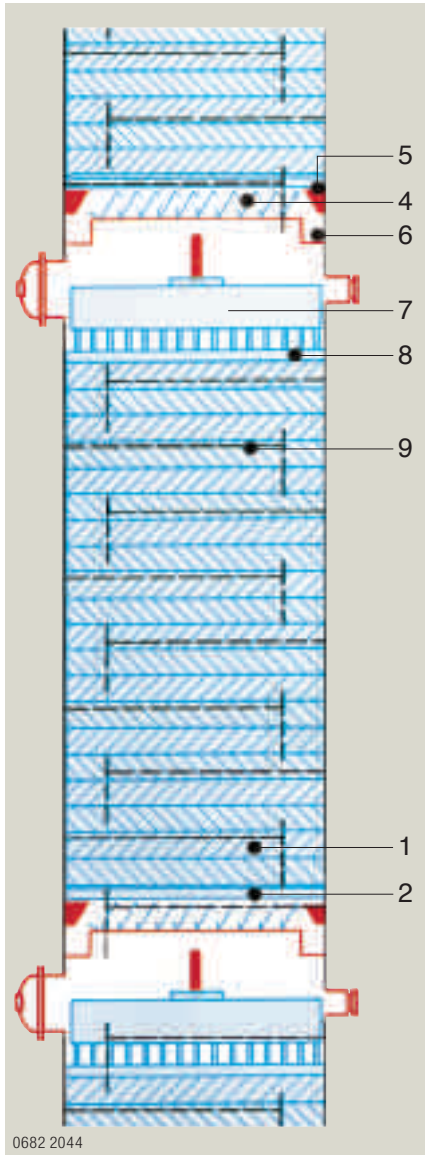

Installation

The new column internals are installed through the manholes: support beam, support grid, packing, locating grid, distributor and collector.

Repacking with column sleeve

To improve product purity without increasing capacity. Due to the good hydraulic performance of the Sulzer structured packings, the entire column cross-section is often not needed. The Sulzer packing is fitted inside a sleeve of smaller diameter.

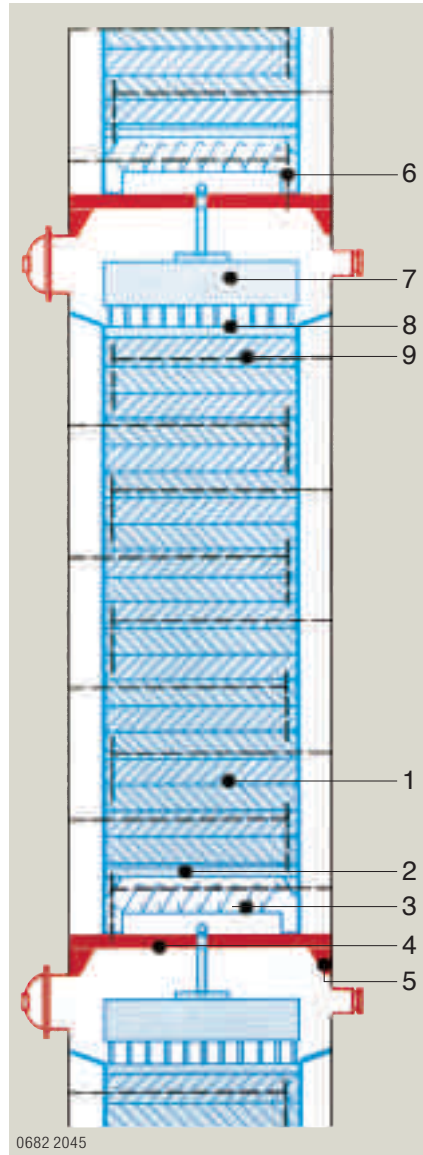

Installation

The column head is taken off and the pre-assembled and pre-packed sleeves are lowered by crane onto the relative beams fitted in the column. The annular spaces are sealed off to prevent gas and liquid by-passing.

- Existing column
- Items supplied by Sulzer Chemtech

Installation either by the customer with Sulzer advising or complete installation service by Sulzer as the customer wishes.

- 1 Sulzer packing
- 2 Support grid
- 3 Support beam
- 4 Collector
- 5 Support lugs (welded-in)
- 6 Ring channel
- 7 Liquid distributor
- 8 Locating grid (hold-down grid)
- 9 Existing trays (incl. support rings)

Repacking work

(Example for tray towers)

- Remove the trays
- Remove tray support rings (when required - depending upon the installation method of the packing)
- Weld in the support lugs, tie-bars and ring channels for the liquid collectors
- Provide manholes and sight glasses at the level of each liquid distributor
- Fit new feed and instrument connections, if necessary
- Clean the column

Repacking time

Depending on the column size and personnel deployed, modifications to the existing column may take one to four weeks, and several days to two weeks for fitting the new parts.

Installation



0695 2510-13

Installation of packing



0692 2512-18

Revamping of a vacuum column with Mellapak



0601 2505-2

Inspecting packings after installation



0683 2006-2

The packing is fitted inside the column sleeves at the preassembly site



0683 2006-1

The column sleeve is lowered into the column with two cranes. Weight: 100 tons



0602 2509-39

Installation of the liquid distributor

Sulzer columns – your solution

Sulzer columns of sectional design

All internals can be installed through the column flange openings

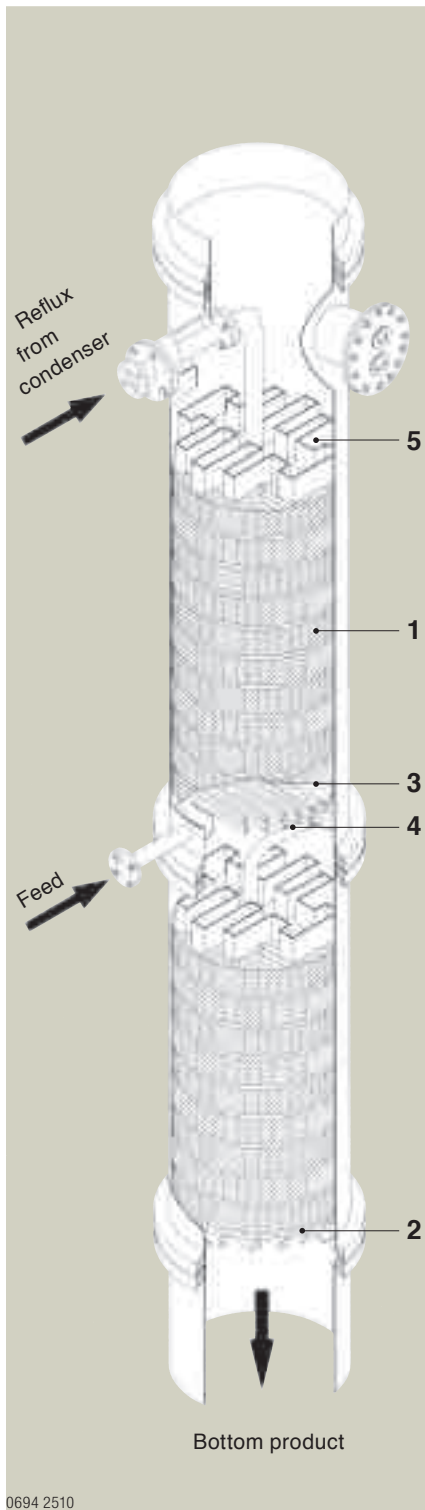

Sulzer packing 1

in various types and different materials

Support grid 2

for the packing

Liquid collector 3

Feed pipe 4

to distributor

Liquid distributor 5

mounted on locating grid

Locating grid 6

Steam inlet pipe 7

Column sump 8

Circulation pipe to reboiler 9

Skirt 10

Anchorage 11

Variations on the above design

Feed:

- vapor
- two phases with flash box

Side stream:

- liquid from collector
- vapor collector

0694 2510

Welded column, monoblock type

All internals in segments for installation and removal through manhole, nominal diameter 500 up to 1000 mm

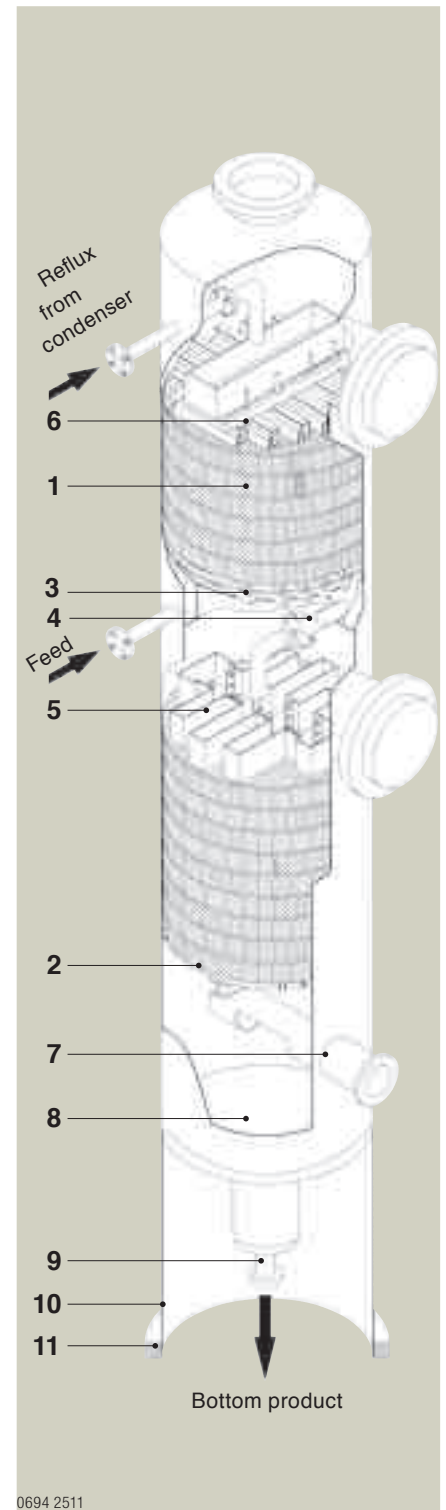

0694 2511

Separation technology laboratory

Comprehensive customer service

Distributor test facility

Uniform liquid distribution is decisive in securing good separation performance from a rectification/absorption column incorporating structured packings especially for columns of large diameter.

This requirement was recognized early on in the development of the Sulzer structured packings. Hence the geometrical configuration of the packings promotes liquid stream intersections and thus intermixing. Moreover, a whole series of liquid distributors has been developed, which are optimally matched for column diameter, packing type and operating conditions.

The distributor test facility has provided results which have contributed significantly to the construction of large distributors with diameters ranging from 3 m up to 15 m. As part of integrated quality control, all distributor types are fully tested before delivery to customers. Sulzer Chemtech is certified in accordance to ISO 9001 : 2000 and ISO 14001.

Laboratories

Sulzer Chemtech has set up a process engineering laboratory in Winterthur, Switzerland for development and testing of structured packings, column internals and trays. At Sulzer Chemtech Allschwil Ltd, a laboratory carries out customer trials and pilot tests. Also an analytical laboratory and trained personnel are available.



0600 2566-1
Distributors on the Sulzer Chemtech distributor test facility



0682 2026
Multi-purpose pilot plant for the separation of mixtures by distillation, using Sulzer structured packings of various design

Formula notation

		Metric Units	To convert to US Units multiply by	US Units
G	Gas flow	kg/h	2.205	lb/h
g	Gas load per square meter (related to empty column)	kg/m ² h	0.2048	lb/ft ² h
L	Liquid flow	kg/h	2.205	lb/h
		m ³ /h	4.403	gpm
ℓ	Specific liquid load (related to empty column)	m ³ /m ² h	0.4090	gpm/ft ²
NTS	Number of theoretical stages	(-)		
NTSM	Number of theoretical stages per meter packed height	m ⁻¹	0.3048	ft ⁻¹
NTUM	Number of transfer units per meter packed height	m ⁻¹	0.3048	ft ⁻¹
HETP	Height equivalent to a theoretical plate	m	39.37	in
c _G	Load factor = $w_G \sqrt{\rho_G / (\rho_L - \rho_G)}$	m/s	3.281	ft/s
F	F factor = $w_G \cdot \sqrt{\rho_G}$	m/s $\sqrt{\text{kg/m}^3} = \sqrt{\text{Pa}}$	0.8197	ft/s $\sqrt{\text{lbm/ft}^3}$
w _G	Superficial gas velocity (related to empty column)	m/s	3.281	ft/s
ρ _G	Gas density	kg/m ³	0.06243	lb/ft ³
ρ _L	Liquid density	kg/m ³	0.06243	lb/ft ³
M	Molar mass	kg/kmol	1.000	lb/lb-mol
p	Operating pressure	mbar	0.7501	mm Hg
		bar	14.50	psia
Δp/Δz	Pressure drop per unit height	mbar/m	0.1224	in H ₂ O/ft
T	Operating temperature	K	1.800	R
A _c	Column cross-section	m ²	10.76	ft ²
d _c	Column diameter	m	3.281	ft
ψ	Flow parameter = $L/G \cdot \sqrt{\rho_G / \rho_L}$	(-)		

Headquarters

Sulzer Chemtech Ltd
P.O. Box 65
8404 Winterthur, Switzerland
Phone +41 52 262 50 28
Fax +41 52 262 01 82
chemtech@sulzer.com
www.sulzerchemtech.com

North and South America

Sulzer Chemtech USA, Inc.
8505 E. North Belt Drive
Humble, TX 77396, USA
Phone +1 281 441 5800
Fax +1 281 291 0207

Asia, Pacific

Sulzer Chemtech Pte. Ltd.
10 Benoi Sector
Singapore 629845
Phone +65 6515 5500
Fax +65 6862 7563

Sulzer Chemtech Ltd, a member of the Sulzer Corporation, with headquarters in Winterthur, Switzerland, is active in the field of process engineering and employs some 2500 persons worldwide. Sulzer Chemtech is represented in all important industrial countries and sets standards in the field of mass transfer and static mixing with its advanced and economical solutions.

The activity program comprises:

- Process components such as fractionation trays, structured and random packings, liquid and gas distributors, gas-liquid separators, and internals for separation columns
- Engineering services for separation and reaction technology such as conceptual process design, feasibilities studies, plant optimizations including process validation in the test center
- Recovery of virtually any solvents used by the pharmaceutical and chemical industry, or difficult separations requiring the combination of special techniques, such as thin film/short-path evaporation, distillation under high vacuum, liquid-liquid extraction, membrane technology or crystallization.
- Complete separation process plants, in particular modular plants (skids)
- Tower field services performing tray and packing installation, tower and column maintenance, vessel welding, and plant turnaround projects
- Mixing and reaction technology with static mixers
- Cartridge-based metering, mixing and dispensing systems, and disposable mixers for reactive multi-component material

Distributed by:

