

# **The Role of Industrial Gases in Fuels and Petrochemicals; Past, Present and Future**

Dante P. Bonaquist, Senior Corporate Fellow and Chief Scientist, Praxair, Inc

[dante\\_bonaquist@praxair.com](mailto:dante_bonaquist@praxair.com)

## **Introduction**

Industrial gases (oxygen, H<sub>2</sub>, CO, nitrogen and CO<sub>2</sub>) have played an integral part in the development of the modern refining and petrochemical industries; yet they function quietly compared to more readily recognized feedstock such as crude oil, natural gas and ethylene. This is due in part to the nature of these gas molecules as fundamental utilitarian building blocks for chemical synthesis as well as their low profile roles as enhancers of safety, quality and productivity and in mitigation of environmental footprint.

Each of the major industrial gas supply modes including pipelines, dedicated on-site production units, refrigerated liquid transport and high pressure cylinders are involved in delivery of gases to refineries, chemical complexes and individual operations within those facilities. The supply modes cited above are capable of delivering cost effective quantities ranging from greater than 100 million scf/day in the case of H<sub>2</sub>, as much as 10,000 tons/ day for oxygen or nitrogen to a few pounds per day for analytical gases and mixtures.

The goal of this paper is threefold:

Summarize primary industrial gas production methods.

Provide an overview of industrial gas utilization in refineries and petrochemical plants up to the present state by highlighting key applications.

Identify emerging technologies and applications that are made possible in part by reliable cost effective industrial gas supply.

## **Gas Production Methods**

**Oxygen and Nitrogen:** For more than 100 years, the only means for producing significant quantities of oxygen and nitrogen for commercial applications has been air separation. Cryogenic distillation has grown with other measures of industrial production, both in total volume of air separated and scale of plants. Today, plants based on cryogenic distillation are capable of producing more than 3,000 tons per day of gaseous oxygen in a single train with or without by-products including gaseous nitrogen as well as liquid oxygen, nitrogen and argon. Oxygen purity in excess of 99.9% is common for plants supplying ethylene oxide facilities although 99.5 % has been the industry standard for general purpose oxygen plants, Special purpose plants have been developed to supply large volumes of gaseous nitrogen for enhanced oil recovery and oxygen for gasification processes. In the near future, large plants with single train

capacity over 5,000 tons per day of oxygen are envisioned for huge clean coal combustion, gasification and coal to liquids facilities. Figure 1 is a schematic of a cryogenic air separation plant.

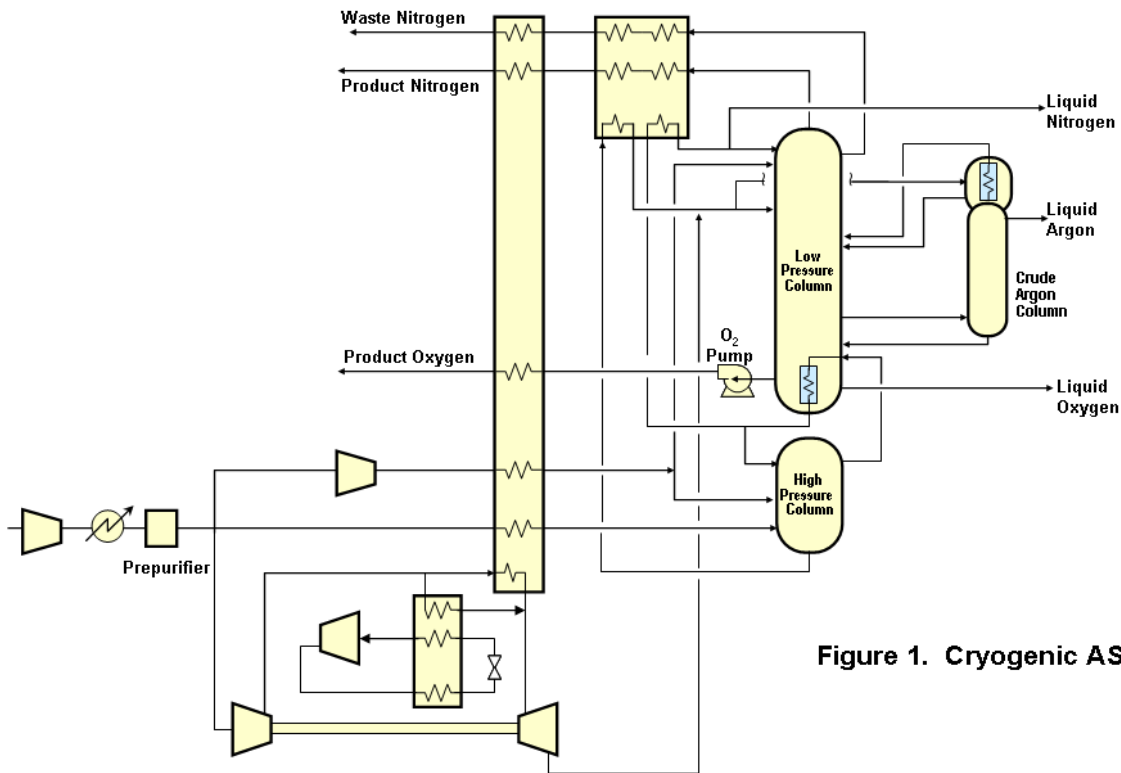

Figure 1. Cryogenic ASU

In the 1970's, pressure swing (PSA) and vacuum pressure swing adsorption (VPSA) were introduced for producing low purity oxygen (90%) for combustion applications. PSA is used to make low purity nitrogen (98%) for inert blanketing. The low specific energy and capital cost of the oxygen VPSA process make it the process of choice for supplying oxygen to applications that can accept lower purity. Initially introduced as a small scale oxygen generator, VPSAs have grown in capacity to 250 tons per day of oxygen for a single train. Figure 2 is a schematic of an oxygen VPSA unit.

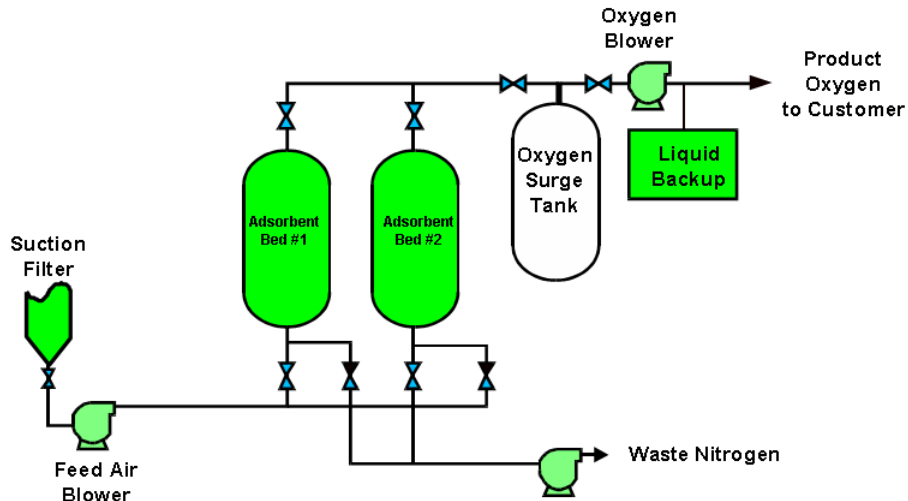

Figure 2. Two-bed VPSA

Commercial polymeric membrane based systems for supplying small to modest volumes of low purity nitrogen were introduced in the early 1980s by Dow (1). The size of the market served by membrane units has grown steadily. The primary attributes of this air separation technology include modular plant design and simplicity of operation. Applications are limited to those where levels of oxygen in the range of 0.5 to 5% can be tolerated.

Figures 3 and 4 show the commercial applicability of various air separation systems based on technologies discussed above.

Figure 3. Preferred Oxygen Supply System

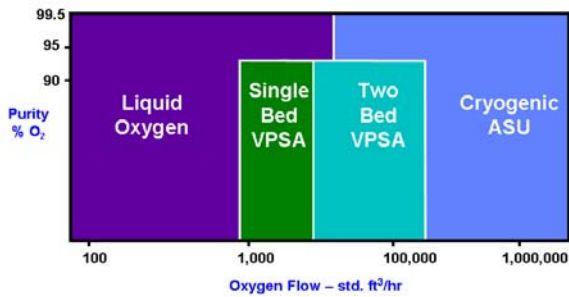
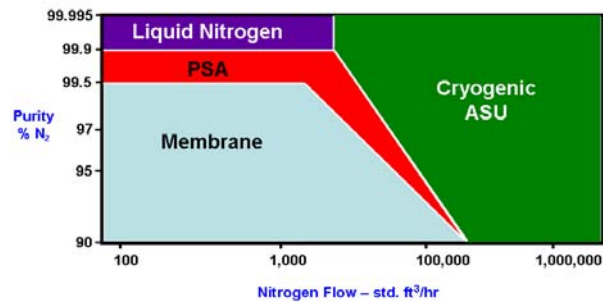

Figure 4. Preferred Nitrogen Supply System



In addition to continuous improvement of current air separation technologies being pursued by all major industrial gas firms, Praxair and Air Products (2,3) are involved in research and development expected to lead to commercialization of air separation using high temperature oxygen conducting ceramic materials called Oxygen Transport Membranes OTM or Ion Transport Membranes (ITM). The primary focus for application of oxygen conducting ceramic membranes is gasification and combustion with CO<sub>2</sub> capture. Figure 5 illustrates the principle of ceramic membrane operation. In this example, the partial pressure driving force is setup by reacting oxygen with a fuel stream as it emerges from the membrane. Compression of air can also provide this driving force.

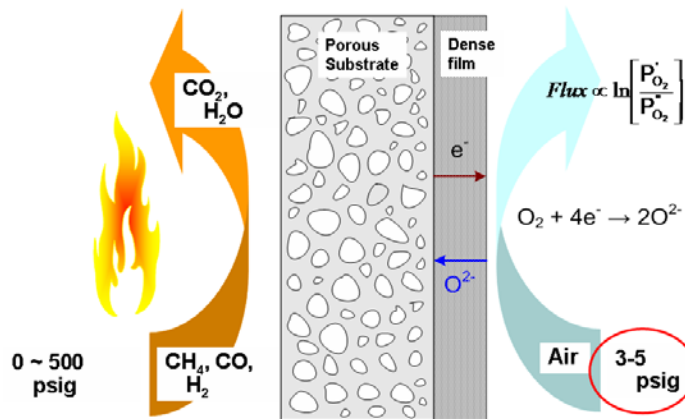
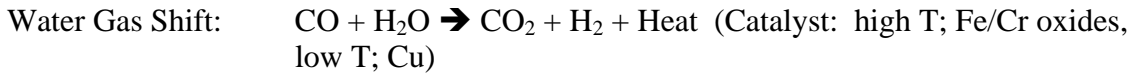

Figure 5. Oxygen Transport Membrane Used for Combustion

**Hydrogen and CO and Syngas:** H<sub>2</sub> and CO are related products made by reforming or partial oxidation of hydrocarbons. Other processes are used commercially to supply H<sub>2</sub>, for example electrolysis of water; however, they are not relevant to refining and petrochemicals. H<sub>2</sub> and CO are commonly supplied together as synthesis gas for the production of methanol and oxo-alcohols (4). The reactions involved for production of H<sub>2</sub> and CO by reforming and partial oxidation are:



H<sub>2</sub> plants consist of a steam methane reformer (SMR) that converts the hydrocarbon carbon feedstock to H<sub>2</sub> and CO, followed by at least one stage of shift conversion to react most of the CO with steam to form CO<sub>2</sub> and more H<sub>2</sub>. Plants design over 25 years ago generally use a second stage of shift conversion to increase yield. Purification of the H<sub>2</sub> product on the older plants is done by absorption of CO<sub>2</sub> using a solvent such as MEA followed by methanation of residual CO and CO<sub>2</sub>. The product is about 97% pure.

In modern plants, the absorption and methanation steps are replaced by a multibed PSA for purification of the H<sub>2</sub> product stream to 99.99% or greater. The higher purity is generally beneficial to customers. The fuel requirements of the SMR furnace are met to a large degree by the PSA tailgas. To improve the thermally efficiency of the reforming process, steam is generally exported, often to the refinery that is the customer for H<sub>2</sub> (5). Figure 6 is a block flow diagram for a hydrogen plant.

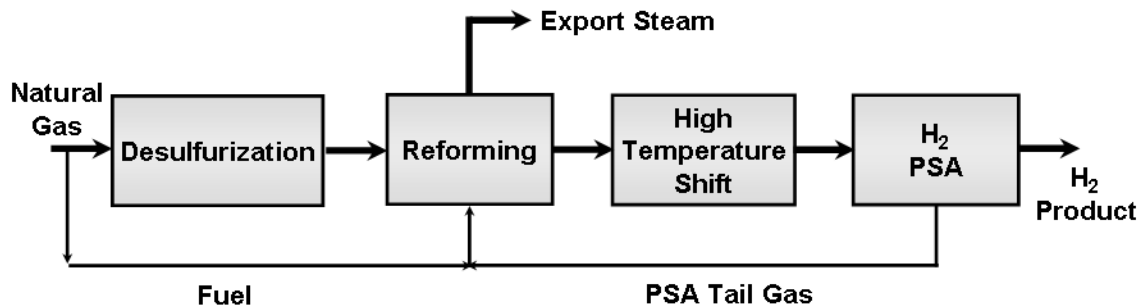

**Figure 6. Hydrogen Plant Block Flow Diagram**

Unlike oxygen and nitrogen that can be liquefied in large volumes to provide backup to air separation units, it is impractical to liquefy H<sub>2</sub> for this purpose. It is therefore advantageous for large H<sub>2</sub> users to receive at least part of their gas from a multi-plant pipeline network such as that operated by Praxair on the US Gulf Coast. As indicated in Figure 7, this system includes a first of a kind H<sub>2</sub> storage cavern created by solution mining of a salt formation that further increases system reliability (6).

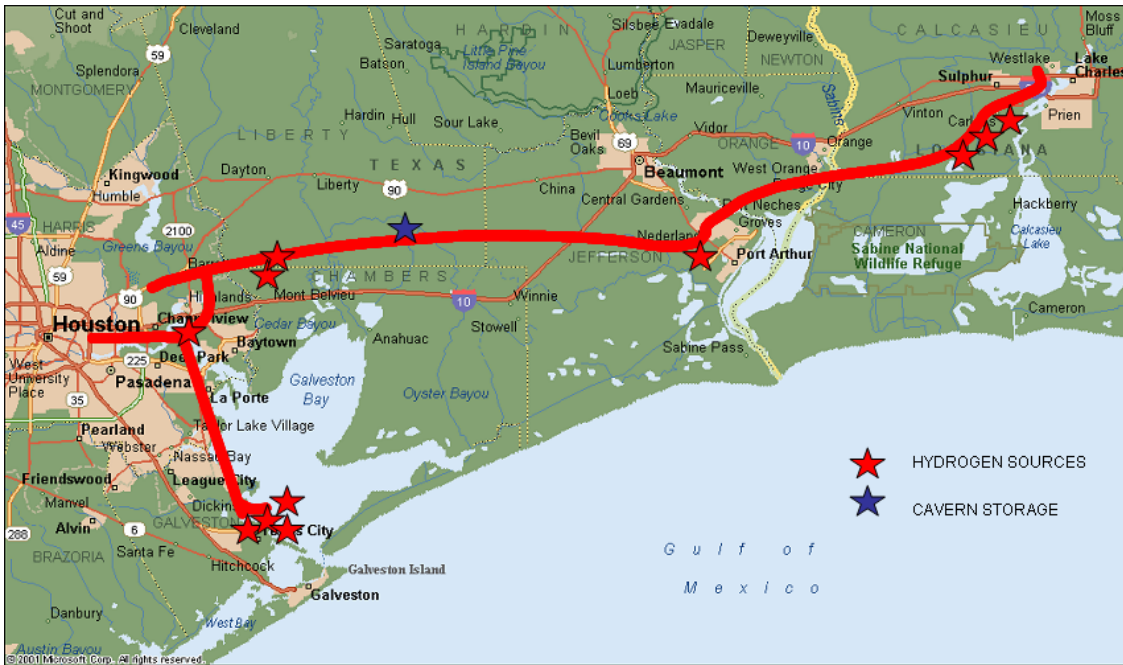

Figure 7. Praxair Gulf Coast Hydrogen System

In addition to “on purpose” production from SMR based plants, H<sub>2</sub> is recovered as a by-product from various refinery and chemical plant off-gases. This is generally economical using a PSA unit for streams containing 50% or more hydrogen by volume. Recently QuestAir working with ExxonMobil has introduced a specialized PSA unit for this purpose (7). A number of PSAs designed by UOP and others are in service for by-product H<sub>2</sub> recovery (8).

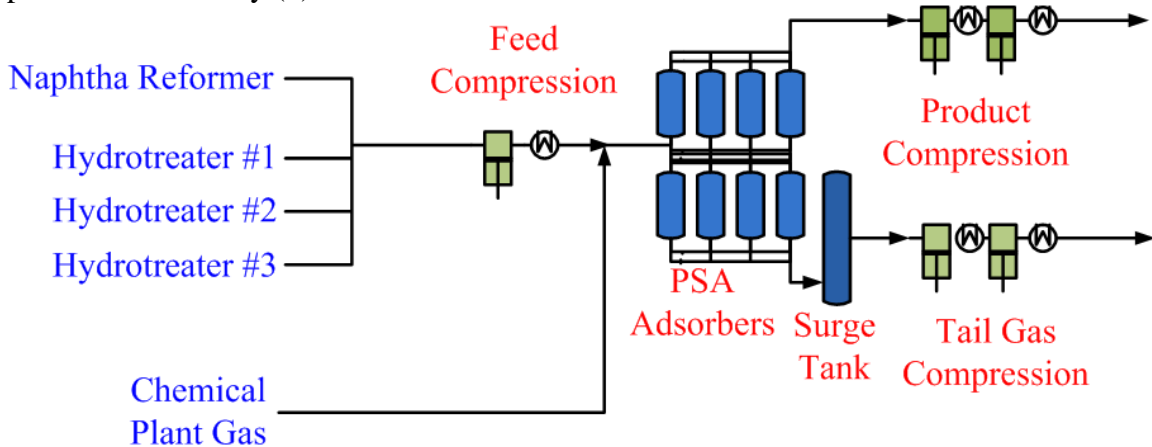

Figure 8. by-Product H<sub>2</sub> Recovery

### Applications – Overview

I have selected several commercially significant refining and petrochemical process to illustrate the linkage between the development of configurations we see today and

primary industrial gases. For a comprehensive treatment, you are encouraged to read Harold Gunardson's book, *Industrial Gases in Petrochemical Processing* (9).

**Oxygen:** Commercially important reactions involving oxygen, either as a pure component, or as oxygen enriched air include (10):

oxygen + paraffins, olefins → aldehydes, alcohols

oxygen + olefins → epoxides

oxygen + refining resid, petcoke, coal → synthesis gas

oxygen + H<sub>2</sub> sulfide → sulfur

**Ethylene Oxide (EO):** Ethylene for feed to EO processes is made by steam cracking of various hydrocarbons. In the US, ethane and propane are common starting points. The current selling price of ethylene (August 2008 spot) is \$0.70/lb. or \$1,400 per ton. To produce EO, ethylene is reacted with oxygen over a silver catalyst at 250 deg. C and 20 atmospheres of pressure.

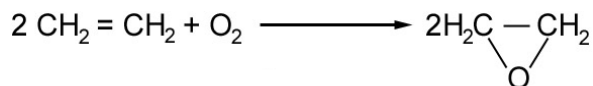

Direct oxidation was first commercialized by Shell in the 1950s replacing the chlorohydrin process where ethylene is reacted with hypochlorous acid (chlorine and water) to make ethylene chlorohydrin. The oxide is formed by treatment of the chlorohydrin with slaked lime or caustic soda (11). Historically air has been used as a source of oxygen; however, state of the art EO plants take advantage of the reduced size and improved selectivity available with high purity oxygen. Higher purity oxygen, 99.95% compared to 99.5%, the industrial standard, will generally allow for increased yield by further maximizing selectivity and minimizing purge losses (12)

Assuming an oxygen price of approximately \$40/ton and a yield of 70% for a commercial EO process, oxygen represents less than 2.5% of the EO feedstock cost. EO is a versatile intermediate used in the production of ethylene glycol and other oxide derivatives such as glycol ethers, polyethylene glycol, polyether polyols, diethylene and triethylene glycols and ethanolamines (13). Most EO producers are integrated with downstream ethylene glycol facilities. World class EO plants with capacities of 0.5B to 1B pounds per year required 400 to 800 tons/day of high purity oxygen. The largest plant in the US is Dow's (formerly Union Carbide) Taft, LA facility with a capacity of 1.5B pounds per year of EO.

**Sulfur Recovery Unit (SRU):** Hydrodesulfurization of transportation fuels to meet clear air standards produces H<sub>2</sub>S that must be treated. The Claus Process, invented by Carl Friedrich Claus in 1883 and further developed by I. G. Farben Industries is the industry standard for recovering elemental S from H<sub>2</sub>S. The overall reaction is:

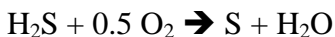

The conversion of  $H_2S$  to S takes place in two distinct steps; combustion of  $H_2S$  to  $SO_2$  followed by a catalytic reaction of  $H_2S$  with  $SO_2$  to form S and water. The primary source of  $O_2$  for the combustion is air; however, enrichment of the combustion air with oxygen has been demonstrated to significantly increase the capacity of an SRU. This is due mainly to higher combustion chamber temperature while avoiding excessive pressure drop that would occur if air flow was increased. For example, enrichment of combustion air to 40% oxygen has been shown to increase SRU capacity by 50% or more (14).

**Hydrogen:** Large amounts of  $H_2$  are produced and consumed for ammonia and methanol synthesis. In the case of ammonia, the  $H_2$  is typically made by steam methane reforming, followed by mixing with air and secondary reforming to obtain a 3:1 ratio of  $H_2$  with nitrogen. There are also a wide variety of chemical processes that use small to moderate amounts of high purity  $H_2$  (>99.9%).

**Refining:** Oil refineries include processes that are both  $H_2$  producers (catalytic reforming) and consumers (hydrotreating and hydrocracking). Hydrotreating and hydrocracking are among the oldest catalytic processes used in refining. Originally employed in Germany for conversion of lignite to gasoline, they were later used to process petroleum residues into distillable streams. The first US installation of commercial hydrorefining was at Standard Oil's Baton Rouge refinery in the 1930s. Due to the availability of Middle Eastern crudes following WWII, the use of hydrorefining experienced little growth. Use of hydrorefining processes accelerated in the 1950s; first as a sink for hydrogen available from catalytic reforming, later as means for control the ratios of gasoline and middle distillates (15). Today, hydrotreating and hydrocracking are critical levers available to refiners to deal with the challenges created by the interaction of reduced crude quality, environmental constraints and market demand (15). Hydrotreating removes contaminants (sulfur, nitrogen) and saturates olefins and aromatics to yield a clean product for further processing or sales. Hydrocracking also removes contaminants while converting low value gas oils to higher value products (naphtha, middle distillates, and ultra-clean lube base stocks) (16). As shown in Figure 9, refineries have become net consumers of  $H_2$  over the past 50 years requiring reliable sources of "on purpose" production to achieve high conversion and meet clean fuel specifications (17).

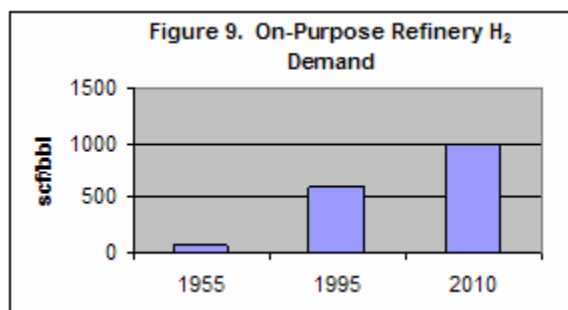

**Nitrogen:** Nitrogen available as a byproduct from a cryogenic oxygen plant was first employed to create an inert atmosphere by the steel industry in the 1940s. Nitrogen is practically inert at modest temperatures and pressures. Following WWII with the rapid

growth of petrochemicals, nitrogen demand increased for blanketing and padding to minimize the possibility of fire and explosions (18). Today, in addition to blanketing, nitrogen is used for mixing, stripping, drying, cooling (liquid nitrogen), emissions control and pressure transfer of liquids. The safety, environmental footprint and efficiency of modern petrochemical and refining operations are all enhanced by the availability of nitrogen.

Nitrogen is also an important fluid used in oil and gas production. Compressed nitrogen is injected down-hole for enhanced oil recovery (pressure maintenance) and gas well fracturing (19).

### **Emerging Applications**

**Gasification:** Natural gas and crude oil form the foundation of today's petrochemicals industry; however, with prices increases and volatility driven by growing demand and shrinking supplies, commercial chemical and energy projects based on gasification of coal, pet coke and biomass are moving forward throughout the world.

Predating the present natural gas supply systems was the town gas industry, an early commercial gasification technology that developed in Europe and the US in the 1800s initially to supply gas for lighting. Starting around 1900, water gas made by reacting carbon and steam to generate an equal molar mixture of H<sub>2</sub> and CO became available to the chemical industry. Water gas is made by a semi-continuous process where steam is passed over hot coke. Energy must be supplied by periodically flowing air over the coke.

It was not until oxygen was made available in large volumes by the commercialization of cryogenic air separation after 1910 that continuous gasification was possible. Modern gasifiers have their roots with the Winkler fluid bed, Lurgi moving bed and Koppoers-Totzek entrained flow processes developed in the 1920s, 30s and 40s respectively (20). Today, Sasol is the leader in the application of oxygen based coal gasification to produce supply the feedstock for synthetic fuel and chemical processes. Sasol's Secunda complex produces and consumes over 40,000 tons per day of oxygen, mostly for gasification (21).

Gasifiers can be air blown, oxygen blown or enriched air blown. The advantages of oxygen blown gasifiers include lower pre-heat temperature, higher carbon conversion and higher heating value of the effluent gas. For power generation applications, the decision of oxidant supply, air or oxygen, is purely economic (22). For chemical synthesis, the nitrogen free syngas from an oxygen blown gasifier is generally preferred. Single train cryogenic ASUs are under development to supply up to 6,000 tpd of oxygen for gasification applications.

**Oxyfuel Combustion for CO<sub>2</sub> Capture and Sequestration:** Combustion with oxygen, oxygen lancing and air enriched with oxygen has been employed in a number of industries (glass, steel and cement). The typical benefits include increased throughput, reduced NO<sub>x</sub> emissions and high thermal efficiency. With many countries moving toward the constraints on CO<sub>2</sub> released into the atmosphere, oxyfuel combustion will play



a role as a means to concentrate CO<sub>2</sub> in flue gas thereby facilitating CO<sub>2</sub> capture and sequestration. For example, in the electric power industry, several commercial demonstrations are planned involving combustion of coal with a mixture of oxygen and CO<sub>2</sub> (23). Figure 10 is a schematic of an oxy-coal fired power plant. Oxygen combustion is also being considered for SAGD boilers and FCC regeneration to enable CO<sub>2</sub> capture.

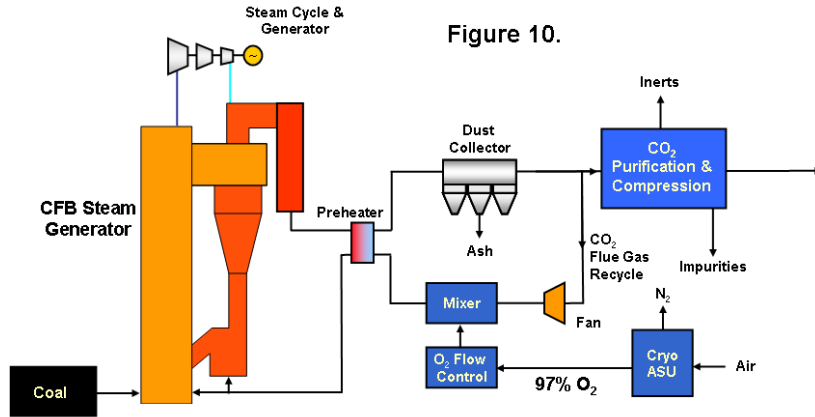

**Biofuels:** As with petroleum based fuels and products, industrial gases will play a role in efforts to make fuels and chemicals from renewable biological sources. For example, UOP has introduced a hydrotreating process for vegetable based feedstock. UOP's Ecofining process deoxygenates feed by adding hydrogen to produce green diesel fuel that is superior to biodiesel and petroleum derived diesel (24).

	Petro-Diesel	Biodiesel (FAME)	Green Diesel
NOx Emission	Baseline	+10	-10 to 0
Cetane	40-55	50-65	75-90
Cold flow properties	Baseline	Poor	Excellent
Oxidative stability	Baseline	Poor	Excellent
Energy content	Baseline	Lower	Similar

## References

1. Baker, R., *Membrane Technology and Applications*, John Wiley and Sons (2004).
2. Li, J., et al, *Progress towards the Demonstration of OTM Integration with Coal Combustion*, 33<sup>rd</sup> International Technical Conference on Coal Utilization & Fuel Systems, Clearwater, Florida (June 1-5, 2008).
3. Allam, R. et al, *Cryogenics & Ceramic Membranes: Current & Future Technologies for Oxygen Supply in Gasification Systems*, 4<sup>th</sup> European Gasification Conference, Noordwijk, The Netherlands (April 11-13, 2000).
4. Isalski, W. *Separation of Gases*; Monographs on Cryogenics 5, Oxford Science Publications (1989).
5. Boyce, Clay et al, *Time for a New Hydrogen Plant?*, Hydrocarbon Processing (February 2004).

6. Morrow, J.M., Corrao, M., and Hylkema, S., *Method of storing and supplying hydrogen to a pipeline*, US Patent US7,078,011 B2 (July 18, 2006).
7. [http://www.questairinc.com/pdf/H6200\\_032008.pdf](http://www.questairinc.com/pdf/H6200_032008.pdf)
8. [http://www.uop.com/objects/Polybed\\_PSA\\_gas\\_extr.pdf](http://www.uop.com/objects/Polybed_PSA_gas_extr.pdf)
9. Gunardson, H., *Industrial Gases in Petroleum Processing*, Marcel Dekker, Inc. (1998).
10. *Industrial Gases in the Chemical Industry*, Linde AG (1999).
11. Lacson, J., *CEH Marketing Research Report – Ethylene Oxide*, Chemical Economics Handbook, SRI International (2003).
12. Papavassiliou, V., Wagner, M. and Day, R., *High purity oxygen for ethylene oxide production*, US Patent 6,040,467 (July 24, 1997).
13. <http://www.dow.com/ethyleneoxide/>
14. Rameshni, M., *Cost Effective Options to Expand SRU Capacity Using Oxygen, Sulfur Recovery Symposium - Brimstone Engineering Services, Inc., Calgary, Alberta (May 6<sup>th</sup>-10<sup>th</sup>, 2002)*.
15. Ackelson, D. *Chapter 7.2; UOP Unicracking Process for Hydrocracking; Handbook of Petroleum Refining Processes, 3<sup>rd</sup> Edition*, Robert Meyers editor, Mc-Graw Hill (2003)
16. Colwell, R., *Oil Refinery Processes: A Brief Overview*, Process Engineering Associates, LLC, <http://www.processengr.com/>
17. Patel, N., et al, *Creating Value Through Refinery Hydrogen Management*, <http://www.h2alliance.com/>
18. Kerry, F., *Industrial Gas Handbook – Gas Separation and Purification*, CRC Press (2007).
19. *Get more oil, from more places, more affordably*, Praxair, Inc. (2007).
20. Higman, C. and M. van der Burgt, *Gasification*, Gulf Western Publishing (2003).
21. [http://www.sasol.com/sasol\\_internet/frontend/navigation.jsp?articleTypeID=2&articleId=7400002&navid=4&rootid=4](http://www.sasol.com/sasol_internet/frontend/navigation.jsp?articleTypeID=2&articleId=7400002&navid=4&rootid=4)
22. Baukal, C., *Oxygen-Enhanced Combustion*, CRC Press (1998).
23. Shah, Minish, Dante Bonaquist and Richard Victor, *Oxy-Coal for CO2 Capture – Technology Development & Demonstration*, The 33rd Annual International Technical Conference on Coal Utilization & Fuel Systems, Clearwater, Florida, USA (June 1-8, 2008).
24. [http://www.uop.com/objects/UOP\\_ENI\\_Ecofining\\_Process%20-%20final.pdf](http://www.uop.com/objects/UOP_ENI_Ecofining_Process%20-%20final.pdf)