

Reduction of Perchlorate and Other Micropollutants in a Hydrogen-Based, Hollow-Fiber Membrane Biofilm Reactor

Robert Nerenberg, University of Notre Dame, Notre Dame, IN

Introduction

The membrane biofilm reactor (MBfR) a novel bioreactor that provides gaseous substrates directly to a biofilm growing on the membrane surface, avoiding the need for sparging. MBfRs are *not* membrane bioreactors (MBRs), where membranes separate suspended solids from the effluent water, substituting for a clarifier. In MBfRs, a gaseous substrate moves across the membrane. Since the MBfR membranes typically are microporous and hydrophobic, water and bacteria do not penetrate and block the pores. This paper describes H₂-based MBfRs for removal of perchlorate and other oxidized micropollutants contaminants.

Membrane Biofilm Reactors

Configuration

One of the key elements of the MBfR is the membrane. Membranes may be made from organic or inorganic materials, and can be configured in sheet or hollow-fiber geometries. Hollow-fiber membranes are commonly used for MBfRs because, with outside diameters as small as 0.1 mm, they provide high surface-to-volume ratios. Hydrophobic materials are preferred because their pores remain dry, and gas molecules diffuse much more quickly through dry pores than through liquid-filled pores (Yang and L. 1986). Dry pores also eliminate the potential for pore fouling.

Hydrophobic, microporous membranes can be operated at high gas pressures without bubbling. When membrane pores are fairly large, such as with silicon membranes, bubbles form when the gas pressure slightly exceeds the hydrostatic pressure of the surrounding liquid (Ahmed and Semmens 1992; Mulder 1997). In contrast, when the pores are small, the water surface tension provide a significant resistance to bubble formation, allowing much higher applied pressures. Higher gas pressures are advantageous, as they allow greater gas fluxes into the biofilm, providing higher rates of biodegradation.

Figure 1 shows a schematic of a bundle of hollow fiber membranes, and a section of a single hollow fiber. As shown on the right side of the figure, the fibers are collected into a gas-supplying manifold at one end and are sealed at the opposite end. On the left side of the figure, pressurized gas in the lumen (interior) of the fiber diffuses through the dry pores and into the biofilm coating the fiber.

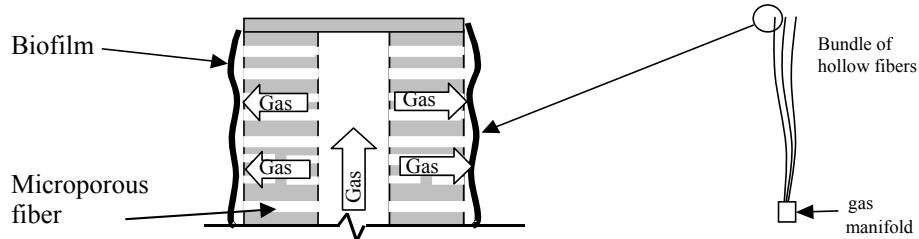

FIGURE 1. Section of fiber (left) and schematic of hollow fiber membrane bundle (right)

Figure 2a shows a scanning electron micrograph (SEM) of the outer surface of a Mitsubishi-Rayon MHF200TL membrane. The average pore diameter is around $0.15\ \mu\text{m}$, with an elliptical shape, and the surface texture is irregular. Figure 2b is a confocal laser scanning microscopy (CLSM) image showing the cross section of a biofilm growing on an MBfR membrane. In this figure, the biofilm thickness is approximately $50\ \mu\text{m}$.

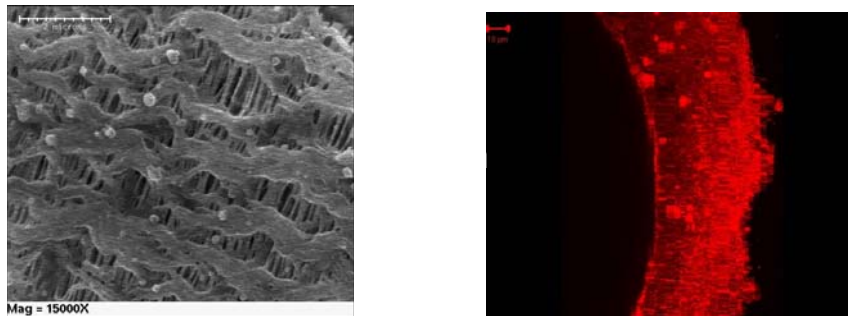

FIGURE 2. (a) Pore structure on the polyethylene surface of a Mitsubishi Rayon MHF200TL16 composite hollow fiber membrane (b) Microscopy image (CLSM) of biofilm growing on hollow-fiber membrane. The red dots are bacteria forming the biofilm, and the outer wall of the membrane (not visible) is immediately left of the biofilm.

Biofilms accumulate naturally on the membrane surface, which is the interface between the gaseous substrate and the dissolved substrate coming from the bulk liquid. Unlike common biofilm applications, where the electron donor and acceptor both diffuse into the biofilm from the bulk liquid (Figure 3a), in an MBfR, one substrate diffused into the biofilm from the membrane and the other from the bulk liquid. This establishes counter-gradients between donor and acceptor (Essila, Semmens et al. 2000; Lee and Rittmann 2002), as shown in Figure 3b. An advantage of counter gradients is that the gaseous substrate supplied from the membrane is “sheltered” from loss into the bulk liquid by the biofilm and by the liquid diffusion layer. Note the high bulk-liquid gas concentration required in Figure 3a, for conventional biofilms, and the much lower bulk-liquid concentration for the MBfR in Figure 3b. If the MBfR gas supply pressure is selected appropriately, very little or no gaseous substrate is lost to the bulk liquid, enhancing the cost-effectiveness of the process.

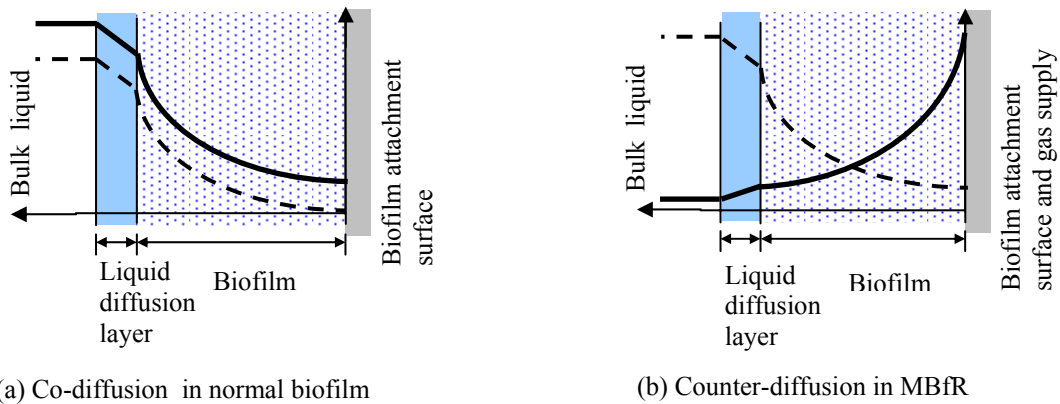

Figure 3. (a) Substrate “co-diffusion” in a normal biofilm and (b) substrate “counter-diffusion” in a hollow-fiber membrane biofilm. The bold line is the dissolved gas concentration, while the dotted line is the substrate from the bulk liquid.

Advantages of MBfRs

A major advantage of the MBfR is that virtually all of the gas passing through the membrane can be utilized within the biofilm. This is due to the counter-current transport of dissolved gas and substrate from the bulk liquid, discussed above. Nearly 100% use of the gas means no unproductive loss of gas with the effluent. It also avoids potential hazards with explosive or toxic gases.

A second advantage is that the gas moves across the membrane wall when the bacterially catalyzed reaction in the biofilm creates a concentration gradient. If the biochemical demand for dissolved gas declines, the gradient of and demand for gas also decline. If the demand increases, the gradient and demand also increase. Thus, to a certain degree the MBfR operates as a self-regulating, on-demand system that modulates its gas supply rate to the contaminant load. This prevents wasting gas or having an under-supply.

A third advantage is that hollow-fiber membranes provide a large specific surface area for biofilm accumulation. A high specific surface area allows a high density of contaminant-reducing bacteria in the MBfR. This means that the detention time for the reactor can be small, thereby minimizing capital costs and the system's footprint. It is ideal for treatment-plant retrofits, as well as for new construction.

Hydrogen-Based MBfRs

One of the most exciting applications of the MBfR is to deliver hydrogen gas (H_2) as an electron donor. Many oxidized contaminants can be reduced to less toxic or less mobile species with the addition of an electron donor. The classical example is nitrate, which can be reduced to nitrogen gas by denitrifying bacteria. Historically, organic donors such as methanol, ethanol, and acetate have been used for denitrification. However, H_2 has following inherent advantages over organic electron donors:

- H₂ is a low-cost source of electrons
- H₂ supports autotrophic bacteria, which eliminates the need for an organic carbon source
- H₂ produces less excess biomass (autotrophic growth)
- H₂ cannot leave a significant residuals that increase effluent BOD (low solubility)
- H₂ is non-toxic to humans
- H₂ can be purchased in bulk or generated on-site

Despite these advantages, H₂ has not been widely used, mainly because no efficient and safe delivery system was available. Its low water solubility does not allow it to be supplied in a water stream, and its flammability and cost does not allow H₂ to be sparged.

The MBfR opens the door using H₂ for water and wastewater treatment. In addition to nitrate, a large number of other, relatively new micropollutants fall into the class of being chemically oxidized. Many can be microbially reduced to innocuous or sequestered products. For example:

- Perchlorate (ClO₄⁻), a component of solid rocket fuel, can be reduced to Cl⁻
- Nitrate (NO₃⁻), a common groundwater contaminant, can be reduced to N₂.
- Chlorinated solvents, like trichloroethene (TCE), can be reductively dehalogenated to ethene and Cl⁻.
- Bromate (BrO₃⁻), an ozonation byproduct, can be reduced to Br⁻.
- Selenate (SeO₄²⁻), which occurs naturally in certain mineral deposits, can be reduced to less mobile selenide (S²⁻) or elemental selenium (Se⁰).
- Heavy metals, particularly chromium, can be reduced from hexavalent chromate (CrO₄²⁻) to less toxic Cr³⁺.
- Radionuclide metals uranium and neptunium can be reduced to low-mobility U(IV) and Np(IV).

The following section describes experience with H₂-based MBfRs.

H₂-MBfR for Perchlorate in Drinking Water

Perchlorate is an emerging oxidized contaminant in areas affected by military bases and rocket manufacturing and testing. Perchlorate affects thyroid function and is considered an endocrine-disrupting compound. Although no federal standard exist yet, the State of California has an action level of 4 µg/L, and the U.S.E.P.A. anticipates that its health-based standard ultimately will be in the range of 5 - 40 µg/L. Perchlorate can be bacterially respired in a stepwise 8-electron reaction that produces Cl⁻ ion. The overall reaction is $\text{ClO}_4^- + 4\text{H}_2 \rightarrow \text{Cl}^- + 4\text{H}_2\text{O}$.

Experiments on a bench-scale MBfR (Figure 4) proved that ClO₄⁻ could be reliably reduced to below 4 µg/L (Nerenberg and Rittmann 2002; Nerenberg, Rittmann et

al. 2002), that the H_2 pressure to the membrane can control the capacity to reduce ClO_4^- , and that prolonged feeding of ClO_4^- enriches the biofilm in perchlorate-reducing bacteria (Nerenberg, Kawagoshi et al. 2008). The bench-scale work also showed that oxygen and nitrate are good electron acceptors to support perchlorate-reducing bacteria, although their concentrations in the MBfR must be very low to preclude inhibition of perchlorate reduction.

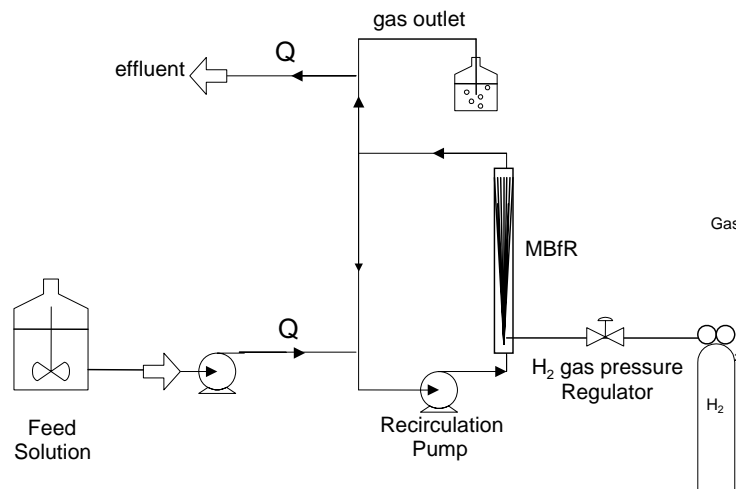

FIGURE 4. Schematic of a bench-scale MBfR

Field-scale pilot testing was carried out at La Puente, California (Nerenberg, Rittmann et al. 2003; Adham, Gillogly et al. 2004). The pilot system consisted of two columns each having $\sim 7,000$ hollow-fiber membranes and received a flow rate around 2 L/min. The La Puente groundwater contained approximately $60 \mu\text{g/L}$ of ClO_4^- and 5.6 mgN/L of NO_3^- . After a start-up period in which practical operating problems were overcome, the pilot-scale system achieved excellent ClO_4^- removal, typically at or below the $4\text{-}\mu\text{g/L}$ action level. Nitrate also was removed to about 0.2 mgN/L , and O_2 was completely removed. One of the most important contributions of the pilot study was quantifying the H_2 use rate, which could not be measured with the small gas flows in the bench-scale studies. The measured H_2 use rate was very close to 100% of the theoretical use rate based on the consumption rate of the three acceptors entering the MBfR: NO_3^- , O_2 , and ClO_4^- . The 100% H_2 use means that the MBfR wastes no electron donor, which is essential for good economy, safety, and effluent quality.

The MBfR is currently being commercially developed by Applied Process Technology, Inc. (APT), Pleasant Hill, CA. APT has carried out numerous bench and pilot-scale tests for removal of perchlorate and other oxidized contaminants.

H_2 -MBfR for Drinking Water Denitrification

K.-C. Lee (Lee and Rittmann 2000; Lee and Rittmann 2002) was one of the first to study MBfRs for drinking water denitrification. The MBfR was inoculated with a pure culture of the H_2 -oxidizing, autotrophic denitrifier, *Ralstonia eutropha*, but was allowed

to develop into a mixed culture. Partial denitrification, to 10 mgN/L, was sought and was achieved by limiting the hydrogen supply. Biofilms were allowed to grow to steady state for two different operating conditions. In the first steady state, the influent nitrate was 10 mgN/L, and the membrane hydrogen supply pressure was 0.31 atm (relative to atmospheric pressure). With a hydraulic retention time of 42 minutes, the system achieved 76% nitrate removal and had 0.9 mgN/L nitrite and 0.009 mgH₂/L hydrogen in the effluent. The average biofilm thickness was 110 μm. The second steady-state had an influent nitrate concentration of 12.5 mgN/L and a hydrogen supply pressure of 0.42 atm. In this case, the system achieved 92% nitrate removal and had 0.7 mgN/L nitrite and 0.7 mgH₂/L hydrogen. The biofilm thickness was 179 μm and the effluent biodegradable dissolved organic carbon (BDOC) was 0.5 mgC/L. The final pH was buffered to between 7.1 and 7.2 for both steady-states. The nitrate fluxes were 0.08 and 0.1 mgNO₃⁻N/cm² biofilm surface area/day for the two steady states, respectively. These studies showed that high nitrate fluxes could be achieved with low effluent hydrogen concentrations, thus allowing a compact and efficient process. Also, the degree of nitrate removal was easily controlled by managing the H₂ supply pressure.

H₂-MBfR for Other Oxidized Micropollutants

In addition to perchlorate, several other oxidized micropollutants have emerged as drinking water contaminants, including arsenate (H₂AsO₄⁻), chromate (CrO₄²⁻), selenate (SeO₄²⁻), and bromate (BrO₃⁻). In many cases, conventional water treatment processes, as well as oxidative processes such as chlorine-oxidation or ozonation, are ineffective. Advanced separation processes, such as reverse osmosis, ion exchange, membrane filtration, and electrodialysis, can be effective, but are expensive and generate concentrated wastes that require proper disposal. Biological reduction may provide a more suitable treatment alternative, especially when the oxidized contaminant is reduced to a less toxic species (Lovley and Coates 1997).

Many oxidized contaminants are reduced in thermodynamically favorable reactions that have been shown to support bacterial growth. However, in some cases the treatment standards may be below bacterial growth thresholds (S_{\min}) (Rittmann and McCarty 2001). In such cases, reduction must occur in parallel to reduction of more amply available “primary” electron acceptors, such as nitrate or oxygen.

Nerenberg and Rittmann (2004) tested a H₂-based MBfR for reduction and removal of several oxidized contaminants when nitrate or oxygen served as primary electron acceptors. The influent concentration of the contaminants was 1 mg/L, while influent oxygen and nitrate were 6 mg/L and 5 mgN/L, respectively. The effluent oxygen and nitrate were below detection. The oxygen reactor had previously been exposed to perchlorate, which explains its higher removals for perchlorate, chlorate, and chlorite. These tests were carried out over a short period of time, without allowing the microbial culture to “adapt” to the new substrate, so long-term efficiencies are likely to be much higher. Results are shown in Table 1.

Table 1. Short-term tests with various oxidized contaminants

Compound	Probable Reduction Reaction(s)	% Removal	
		O ₂ Reactor	NO ₃ ⁻ Reactor
Arsenate	$\text{H}_2\text{AsO}_4^- + \text{H}_2 + \text{H}^+ \rightarrow \text{H}_3\text{AsO}_3 + \text{H}_2\text{O}$	>50	>50
Bromate	$\text{BrO}_3^- + 3\text{H}_2 \rightarrow \text{Br}^- + 3\text{H}_2\text{O}$	>95	>95
Chlorate	$\text{ClO}_3^- + 3\text{H}_2 \rightarrow \text{Cl}^- + 3\text{H}_2\text{O}$	>95	29
Chlorite	$\text{ClO}_2^- + 2\text{H}_2 \rightarrow \text{Cl}^- + 2\text{H}_2\text{O}$	>75	67
Chromate	$\text{CrO}_4^- + 1.5\text{H}_2 + 2\text{H}^+ \rightarrow \text{Cr}(\text{OH})_3$	>75	>75
Dichloro-methane	$\text{DCM} + 2 \text{H}_2 \rightarrow \text{CH}_4 + 2\text{H}^+ + 2 \text{Cl}^-$	38	45
Nitrate	$\text{NO}_3^- + 2.5\text{H}_2 + \text{H}^+ \rightarrow 0.5\text{N}_2 + 3\text{H}_2\text{O}$	Not tested	>99
Perchlorate	$\text{ClO}_4^- + 4\text{H}_2 \rightarrow \text{Cl}^- + 4\text{H}_2\text{O}$	>98	36
Selenate	$\text{SeO}_4^{2-} + 3\text{H}_2 + 2\text{H}^+ \rightarrow \text{Se}^0 + 4\text{H}_2\text{O}$	67	74
Selenite	$\text{HSeO}_3^- + 2\text{H}_2 + \text{H}^+ \rightarrow \text{Se}^0 + 3\text{H}_2\text{O}$	93	57

Both reactors showed significant removals for all tested contaminants. Removals ranged from 29% for chlorate in the NO₃⁻ reactor to over 98% for perchlorate in the O₂ reactor. These results show that many oxidized contaminants can be removed in an MBfR. No specialized inoculum was required, in all cases the required bacteria were present in the mixed culture obtained from an environmental inoculum. Subsequent, more detailed tests have confirmed and expanded the above findings (Chung, Li et al. 2006; Chung, Nerenberg et al. 2006; Chung, Nerenberg et al. 2006; Chung, Ryu et al. 2006; Chung, Nerenberg et al. 2007; Chung and Rittmann 2007; Chung, Rittmann et al. 2007; Downing and Nerenberg 2007).

Oxygen-Based MBfRs

Researchers have also used O₂-based MBfRs for nitrification of drinking water (Brindle and Stephenson 1996) and nitrification and denitrification of wastewater (Syron and Casey 2008). An exciting new strategy is to use the O₂-based MBfR for concurrent nitrification, denitrification, and BOD removal (Semmens, Dahm et al. 2003; Terada, Hibiya et al. 2003; Downing and Nerenberg 2008).

Conclusions

The MBfR is an effective means to deliver gaseous substrates for biological processes, opening the door to a myriad of new applications in water and wastewater treatment. Key applications include nitrification/denitrification and removal of emerging oxidized contaminants. Almost all the supplied gas is delivered to the biofilm, where it is used for desired biochemical reactions, so little waste occurs. The process has a self regulating feature, where increased gas demand from the biofilm creates a greater driving force for gas supply from the membrane. Also, the hollow-fiber membrane configuration

also provides high specific surface areas, allowing for compact reactors. The MBfR has been shown to be effective for numerous applications at the bench and pilot scale. Commercial configurations are being developed.

References

- Adham, S., T. Gillogly, et al. (2004). "Development of a Membrane Biofilm Reactor (MBfR) for Nitrate and Perchlorate Removal." AWWARF.
- Ahmed, T. and M. J. Semmens (1992). "Use of sealed end hollow fibers for bubbleless membrane aeration: experimental studies." Journal of Membrane Science **69**: 1-10.
- Brindle, K. and T. Stephenson (1996). "Nitrification in a bubbleless oxygen mass transfer membrane bioreactor." Water Science and Technology **34**(9): 261-267.
- Chung, J., X. H. Li, et al. (2006). "Bio-reduction of arsenate using a hydrogen-based membrane biofilm reactor." Chemosphere **65**(1): 24-34.
- Chung, J., R. Nerenberg, et al. (2006). "Bio-reduction of soluble chromate using a hydrogen-based membrane biofilm reactor." WATER RESEARCH **40**(8): 1634-1642.
- Chung, J., R. Nerenberg, et al. (2006). "Bioreduction of selenate using a hydrogen-based membrane biofilm reactor." Environmental Science & Technology **40**(5): 1664-1671.
- Chung, J., R. Nerenberg, et al. (2007). "Evaluation for biological reduction of nitrate and perchlorate in brine water using the hydrogen-based membrane biofilm reactor." Journal of Environmental Engineering-Asce **133**(2): 157-164.
- Chung, J. and B. E. Rittmann (2007). "Bio-reductive dechlorination of 1,1,1-trichloroethane and chloroform using a hydrogen-based membrane biofilm reactor." Biotechnology and Bioengineering **97**(1): 52-60.
- Chung, J., B. E. Rittmann, et al. (2007). "Simultaneous bio-reduction of nitrate, perchlorate, selenate, chromate, arsenate, and dibromochloropropane using a hydrogen-based membrane biofilm reactor." Biodegradation **18**(2): 199-209.
- Chung, J., H. Ryu, et al. (2006). "Community structure and function in a H₂-based membrane biofilm reactor capable of bioreduction of selenate and chromate." Applied Microbiology and Biotechnology **72**(6): 1330-1339.
- Downing, L. and R. Nerenberg (2007). "Kinetics of Microbial Bromate Reduction in a Hydrogen-Oxidizing, Denitrifying Biofilm Reactor." Biotechnology and Bioengineering **98**(3): 543-550.
- Downing, L. and R. Nerenberg (2008). "Total Nitrogen Removal in a Hybrid, Membrane-Aerated Activated Sludge Process. ." Water Research **42**(14): 3697-3708.
- Essila, N. J., M. J. Semmens, et al. (2000). "Modeling biofilms on gas-permeable supports: concentration and activity profiles." Journal of Environmental Engineering **126**(3): 250-257.
- Lee, K.-C. and B. E. Rittmann (2000). "A novel hollow-fiber membrane biofilm reactor for autohydrogenotrophic denitrification of drinking water." Water Science and Technology **41**(4-5): 219-226.

- Lee, K.-C. and B. E. Rittmann (2002). "Applying a novel autohydrogenotrophic hollow-fiber membrane biofilm reactor for denitrification of drinking water." Water Research **36**(8): 2040-2052.
- Lovley, D. R. and J. D. Coates (1997). "Bioremediation of metal contamination." Current Opinion in Biotechnology **8**(3): 285-289.
- Mulder, M. (1997). Basic principles of membrane technology????
- Nerenberg, R., Y. Kawagoshi, et al. (2008). "Microbial Ecology of a Perchlorate-Reducing, Hydrogen-Based Membrane Biofilm Reactor." Water Research **42**(4-5): 1151-1159.
- Nerenberg, R. and B. E. Rittmann (2002). "Perchlorate as a Secondary Substrate in a Denitrifying Hollow-Fiber Membrane Biofilm Reactor." Water Science and Technology: Water Supply **2**(2): 259-265.
- Nerenberg, R. and B. E. Rittmann (2004). "Reduction of oxidized water contaminants with a hydrogen-based, hollow-fiber membrane biofilm reactor." Water Sci. Technol. **49**(11-12): 223-230.
- Nerenberg, R., B. E. Rittmann, et al. (2003). Perchlorate Reduction using a Hollow-Fiber Membrane Biofilm Reactor: Kinetics, Microbial Ecology, and Pilot-Scale Studies. Battelle Bioremediation Conference 2003, Orlando, FL.
- Nerenberg, R., B. E. Rittmann, et al. (2002). "Perchlorate Reduction in a Hydrogen-Based Membrane-Biofilm Reactor." J. AWWA **94**(11): 103-114.
- Rittmann, B. E. and P. McCarty (2001). Environmental Biotechnology: Principles and Applications. New York, McGraw-Hill.
- Rittmann, B. E., R. Nerenberg, et al. (2004). "Hydrogen-Based Membrane Biofilm Reactor for Wastewater Treatment." War. Sci. Tech. **In press**.
- Semmens, M. J., K. Dahm, et al. (2003). "COD and nitrogen removal by biofilms growing on gas permeable membranes." Water Research **37**(18): 4343-4350.
- Syron, E. and E. Casey (2008). "Membrane-Aerated Biofilms for High Rate Biotreatment: Performance Appraisal, Engineering Principles, and Development Requirements." Environmental Science & Technology.
- Terada, A., K. Hibiya, et al. (2003). "Nitrogen Removal Characteristics and Biofilm Analysis of a Membrane-Aerated Biofilm Reactor Applicable to High-Strength Nitrogenous Wastewater." Journal of Bioscience and Bioengineering **95**(2): 170-178.
- Yang, M.-C. and C. E. L. (1986). "Designing hollow-fiber contactors." American Institute of Chemical Engineering Journal **32**(11): 1910-1916.