

Application of Helmholtz Resonance to Determination of Bulk Density and Fill Fraction of dry particulate solids

Emile S. Webster and Clive E. Davies

School of Engineering and Advanced Technology
Massey University, New Zealand

INTRODUCTION

Helmholz resonance is the term for resonance occurring in a cavity linked to the surrounding atmosphere via a constricted neck or necks. The resonant frequency is principally determined by the volume of the cavity and the dimensions of the neck (s). An object placed inside a resonator reduces its effective volume, and it follows that for a well defined system, the volume of the object can be estimated.

Such a system is thus potentially useful for characterizing bulk volumes of particulate solids, and hence the degree of fill in a container or bin, though we anticipate constraints and limitations with large bins, dictated by the low resonant frequencies of large volumes.

Experiments have been carried out with a 3 liter resonator using a variety of particulate materials including glass ballotini and sand. Degree of fill is calculated and compared with values estimated from direct measurements of material mass and particle density measured off-line.

THEORY

The resonant frequency of a Helmholtz resonator is given by Equation 1:

$$Freq_{res} = \frac{c}{2\pi} \sqrt{\frac{s_p}{V_c l_p}} \quad (1)$$

where $Freq_{res}$ is resonant frequency, c is velocity of sound; s_p is cross sectional area of the port; V_c is volume of the empty chamber; and l_p is corrected length of the port.

Rearrangement of Equation 1 gives Equation 2, which relates the volume, w , of an object placed in the resonant chamber to the empty chamber volume:

$$w = V_c - \frac{s_p}{l_p \left(\frac{2\pi Freq_{res}}{c} \right)^2} \quad (2)$$

EXPERIMENTAL

All experiments were conducted with a 3 L chamber made of 140 mm inside diameter Perspex tube. The chamber had a single port with an internal diameter of 22 mm and was 170 mm long. The acoustic signals were sensed by two PCB103A sound pressure microphones; one was located in the centre of the base, and the other was located at the top of the 170 mm port. The sound source was an 8 inch infinite baffle loud speaker with a flat linear response over the frequency range 80 Hz to 500 Hz expected in this investigation. Figure 1 is a SolidWorks drawing of the resonator chamber, and Figure 2 is a photograph of the loudspeaker and resonator.

Signal and data acquisition were carried out using a National Instruments PCI 6024 M series DAQ. Audio generation and acquisition were carried out simultaneously at 100 kHz. A pink noise source was first applied to the resonator so that the approximate value of the resonant frequency could be established. A further sweep was then made to refine the estimate to within ± 2 kHz. This was followed by a very narrow sweep, enabling the detection of resonant frequency to within ± 0.005 Hz. Air temperature in the chamber was also recorded.

The test materials used were water, sand with a Sauter mean diameter of 166 μm , glass ballotini with a Sauter mean diameter of 261 μm , glass ballotini with a Sauter mean diameter of 713 μm , marbles with a mean diameter of 15 mm and marbles with a mean diameter of 24 mm. Experiments were carried out by placing a known mass of material in the chamber, calculating associated volume and then finding the resonant frequency of the chamber, and then calculating the volume of the object.

A fuller description of the experimental apparatus and method is given by Webster and Davies (2008).

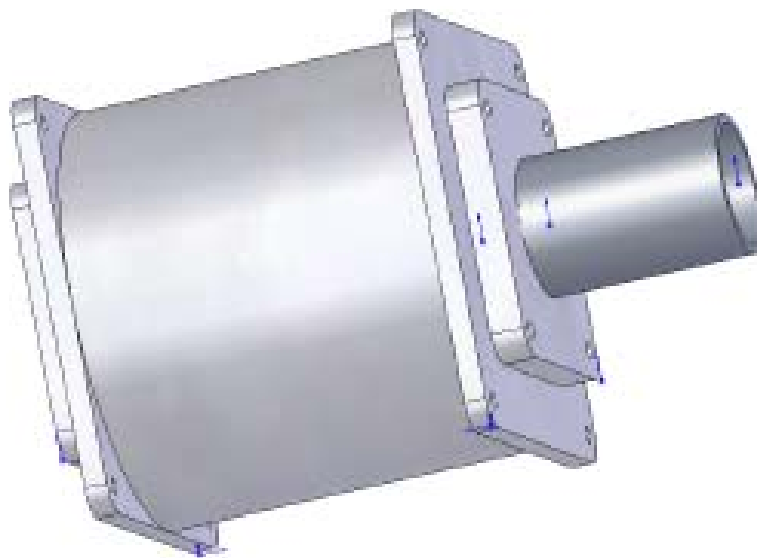

Figure 1 SolidWorks drawing of 3 L resonator.



Figure 2 Photograph of loud speaker and 3 L resonator.

RESULTS AND DISCUSSION

Figure 3 shows the results of a calibration test run with water and Figure 4 shows a comparison of actual volume and the predicted volume of the material placed in the chamber. It can be seen that the measured and predicted resonant frequencies when water is used to alter chamber volume are in excellent agreement. Likewise there is very good agreement between experiment and theory for the large marbles, small marbles and water. However for the smaller materials, *i.e.* the glass ballotini and sand, there is a considerable difference between measured and predicted values, and the relationship between these is non-linear, particularly at higher volumes.

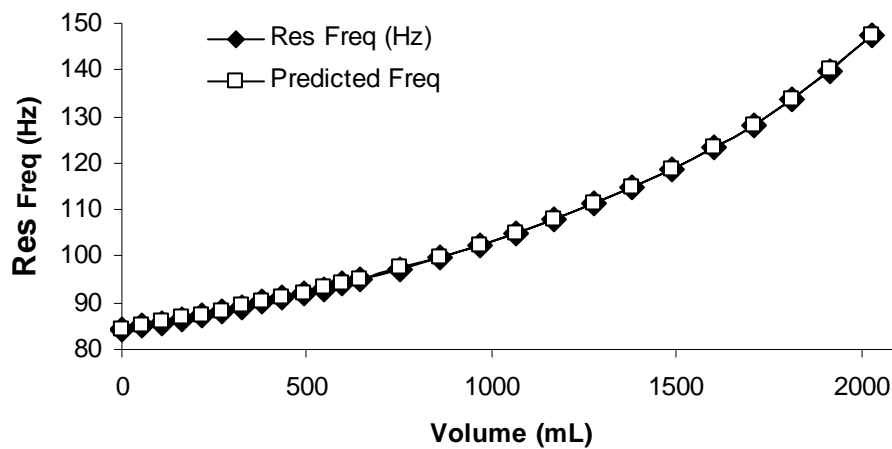

Figure 3 Actual and predicted resonant frequency shown as a function of volume of water in chamber, for the 3 L resonator.

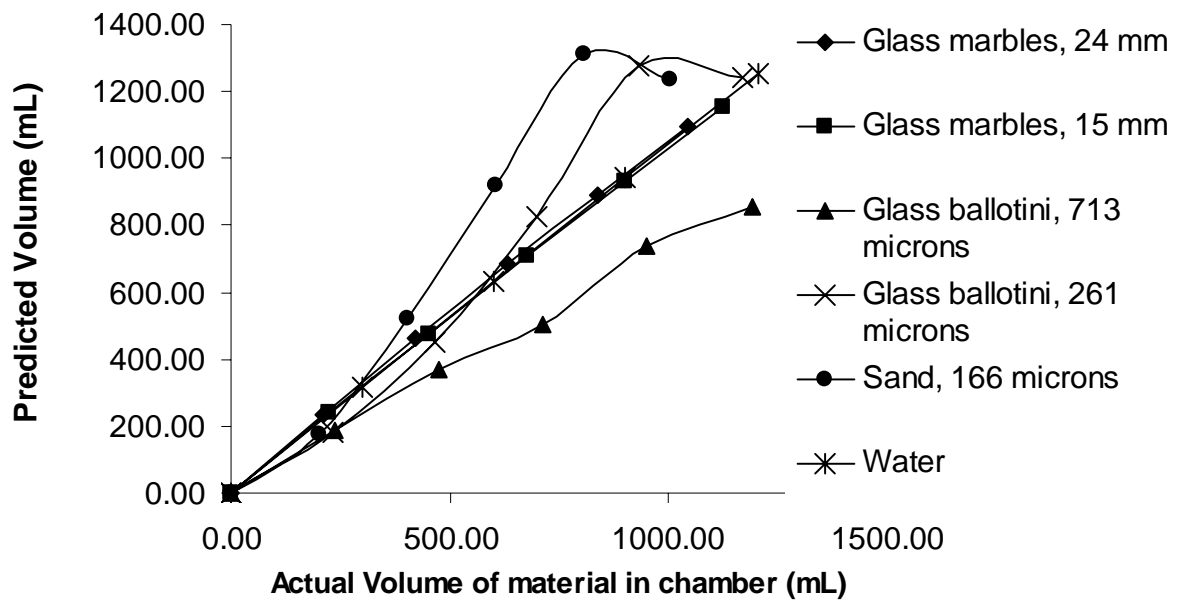

Figure 4 Actual and predicted volumes of material in 3 L resonator.

ACKNOWLEDGEMENT

ESW acknowledges financial support from a Massey University postgraduate scholarship.

REFERENCE

Webster, E. S. and Davies, C. E., 2008. "Determination of Bulk Density and Fill Fraction of Dry Particulate solids Using Helmholtz Resonance", SCENZ Conference, Hamilton, New Zealand, 20 October.