

# Sublimation and Vapor pressures of heavy n-alkanes by Gas Saturation method

**Ramy Abou Naccoul**, *Laboratoire des sciences analytiques, UMR5180, Université Claude Bernard Lyon1, Villeurbanne, France*

**Antonio Razzouk**, *Laboratoire des sciences analytiques, UMR5180, Université Claude Bernard Lyon1, Villeurbanne, France*

**Joseph Saab**, *Université Saint Esprit de Kaslik, Faculté de Sciences et genie, Kaslik, Lebanon*

**Ilham Mokbel**, *Laboratoire des sciences analytiques, UMR5180, Université Claude Bernard Lyon1, Villeurbanne, France*

**Naim Ouaini**, *Université Saint Esprit de Kaslik, Faculté de Sciences et genie, Kaslik, Lebanon*

**Jacques Jose**, *Laboratoire des sciences analytiques, UMR5180, Université Claude Bernard Lyon1, Villeurbanne, France*

## Abstract

Vapor and sublimation pressures of three n-alkanes C<sub>20</sub>, C<sub>24</sub> and C<sub>28</sub> in the temperature range 303-413K were determined. The measurements were carried out by a modified gas saturation technique using a reference compound in order to improve the accuracy of the data. The obtained pressure values range from 10<sup>-5</sup> Pa to 5.5 Pa. The experimental data were fitted to Clausius-Clapeyron equation in order to determine vaporization and sublimation enthalpies. The triple point was deduced graphically from the intersection point between the two plots of solid and liquid states.

## Introduction

Vapor pressures of heavy n-alkanes are of practical importance in petroleum industry for the characterization of heavy petroleum cut and synthetic fluids. These data are also needed for thermodynamic calculations and in order to estimate properties of other classes of compounds. Although vapor pressures of normal alkanes up to n-C<sub>30</sub> are available in the literature<sup>1-7</sup>, sublimation pressures are practically inexistent.

In previous works<sup>5-6</sup> we reported vapor pressures of some alkanes up to n-C<sub>30</sub>. Continuing this research line, the vapor and sublimation pressures of three normal alkanes, n-C<sub>20</sub>, n-C<sub>24</sub> and n-C<sub>28</sub> have been measured using the gas saturation method. Enthalpy of vaporization ( $\Delta H_{\text{vap}}$ ) and sublimation ( $\Delta H_{\text{sub}}$ ) have also been determined from the vapor and sublimation pressures and compared with the existing literature data.

## Experimental

### Chemical

The suppliers and the purities of the used materials are as follow: C<sub>16</sub> (Janssen, 99%); C<sub>20</sub> and C<sub>24</sub> (Aldrich, 99%); C<sub>28</sub> (Acros Organics, 99+%). All compounds were used without any further purification.

### Apparatus

The apparatus for the vapor and sublimation pressure determination is based on the gas saturation method, also known as the transpiration method. The apparatus allows reliable measurements within a large pressure interval ranging from 10<sup>-5</sup> Pa to 10<sup>3</sup> Pa. The description in details of the saturation apparatus can be found elsewhere<sup>6,7</sup>. The experimental apparatus, presented in Figure 1, is composed of two parts. The sampling part consists of an equilibrium oven containing two saturators, which are constituted by stainless steel columns, filled with a porous gas chromatography support respectively impregnated with the sample and the standard compound.

The second part is a gas chromatograph (GC) equipped with a SGE BPX1 column (length : 10m, i.d.: 0.53 mm, film thickness : 2.65  $\mu\text{m}$ ) and a FID detector.

When thermal equilibrium is reached, both compounds are simultaneously swept by the inert gas  $\text{N}_2$  into the cold GC column where they are trapped. In order to limit adsorption and desorption phenomena, we modified the connection between the saturators and the GC. A silica capillary tube T is connected to the outlet tube of the saturators in one side, whereas the other end penetrates inside the GC column. Under these conditions the carrier gas does not pass through the union tube of fused silica and desorbs only the compounds trapped in the analysis column. By heating the capillary column, the two compounds are eluted and detected by the FID. The present apparatus is totally automatic as all the valves are controlled by the GC output.

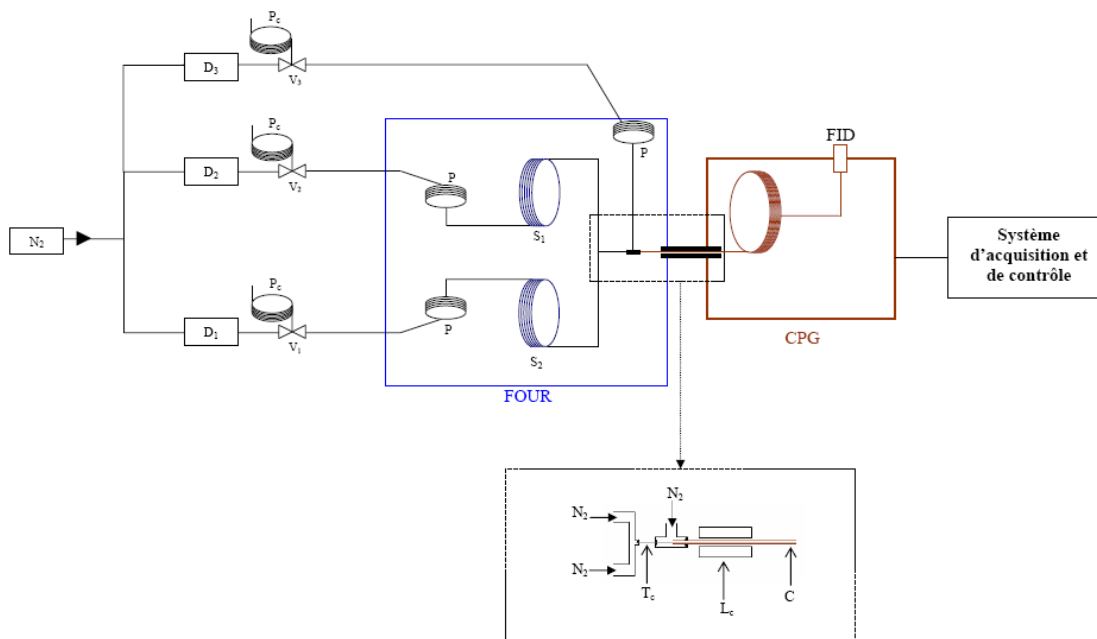

**Figure 1.** Saturation apparatus. A : Chemstation acquisition from Agilent; C : analytical capillary column;  $F_1, F_2, F_3$  : mass flow meters from Bronkhorst, flow range  $0\text{--}10\text{ mL}\cdot\text{min}^{-1}$ , uncertainty 1%; H : heated zone;  $S_1, S_2$  : saturation stainless steel column ( $L = 2\text{m}$ ; i.d. =  $2.1\text{ mm}$ ) containing Gas Chrom P support (particle diameter :  $147\text{--}175\ \mu\text{m}$ ); SG : saturation gas; T : capillary silica tube ( $L = 25\text{ cm}$  ; i.d. =  $0.32$ );  $T_1, T_2, T_3$  : stainless steel tubing ( $L = 3\text{m}$ ; i.d. =  $0.50\text{mm}$ ) for saturation and carrier gas preheating;  $V_1, V_2, V_3$  : electrovalves controlling gas flow

### ***Impregnation of the support.***

The impregnation of the support by the sample or the standard compound is done by batch mode. A mass of  $0.5\text{ g}$  of the compound was dissolved in an organic solvent. Then, the chromatographic support (“Gas Chrom P”  $147\text{--}175\ \mu\text{m}$ ) was added to the solution in a way to have a ratio “compound weight/support weight” equal to 20%. Afterward, the cell containing the mixture was subjected to the action of an oscillating stirrer for 24 h before totally evaporating the solvent using a rotary evaporator under vacuum. Finally, the dry support impregnated with the compound was finally introduced into the saturation column.

### ***Saturation gas flow rate and purge time***

A preheated nitrogen steam was passed through the saturators at constant temperature. The flow rates were measured with an uncertainty of 1%, using mass flow meters from Bronkhorst with a real time monitoring system. The flow rates were optimized in order to reach the saturation equilibrium of the gas. Thus experiments were carried out using flow rates ranging from 3 and  $10\text{ mL}\cdot\text{min}^{-1}$  according to the equilibrium temperature and the volatility of the compounds. The same trap time was applied to both sample and reference compounds. It varies between 30 min and 10 h.

### ***Vapor pressure determination.***

The vapor pressures were calculated using the following equation which supposes an ideal behavior of the vapor phase:

$$\frac{P_1}{P_2} = k \frac{A_1 M_2 F_2}{A_2 M_1 F_1} \quad (1)$$

Subscripts  $i = 1$  and  $i = 2$  refer, respectively, to the standard and the sample;  $P_i$  is the vapor pressure;  $A_i$  is the chromatographic peak area;  $M_i$  is the molar mass;  $F_i$  is the saturation gas flow rate and  $k$  is the relative response factor of the FID. For normal alkanes the response factor  $k$  is equal to unity<sup>6</sup>.

## **Results and discussion**

Vapor and sublimation pressures of the three n-alkanes were determined and fitted to the Clausius-Clapeyron equation :

$$\ln P \text{ (Pa)} = B - \frac{A}{T \text{ (K)}} \quad (2)$$

$$\text{With } A = \frac{\Delta H^{\text{vap or sub}}}{R} \quad (3)$$

From the fits we deduced the enthalpy of vaporization and sublimation. The melting enthalpy was calculated using the following equation:

$$\Delta H^{\text{fus}} = \Delta H^{\text{sub}} - \Delta H^{\text{vap}} \quad (4)$$

Where  $\Delta H^{\text{fus}}$  is the melting enthalpy,  $\Delta H^{\text{sub}}$  is the sublimation enthalpy and  $\Delta H^{\text{vap}}$  is the vaporization enthalpy. In the same way, the triple point could be deduced by equalizing the Clausius-Clapeyron equations of solid and liquid states.

### ***Vapor and sublimation pressures of n-C<sub>20</sub>***

The vapor and sublimation pressures of n-C<sub>20</sub> (Table 1) were determined using n-C<sub>16</sub> as standard compound. The values of the latter were taken from Ruzika and Mayer.<sup>8</sup> The enthalpies of vaporization and sublimation obtained from the Clausius-Clapeyron equation fitted on our experimental results (Figure 2) are respectively 99.5 kJ.mol<sup>-1</sup> and 173.6 kJ.mol<sup>-1</sup>. The melting enthalpy obtained from equation 4 is 74.1 kJ.mol<sup>-1</sup>. The temperature and the pressure at the triple point are respectively 307.5 K and 0.00549 Pa.

**Table 1. Vapor pressure of n-C<sub>20</sub>**

	T /K	P /Pa
Solid state	302.37	$1.73 \times 10^{-3}$
	307.86	$5.94 \times 10^{-3}$
Liquid state	312.76	$1.13 \times 10^{-2}$
	322.82	$3.45 \times 10^{-2}$
	327.82	$6.01 \times 10^{-2}$
	337.82	$1.74 \times 10^{-1}$
	342.89	$2.93 \times 10^{-1}$
	373.17	5.45

### *Vapor pressure of n-C<sub>24</sub>*

Vapor pressures of n-C<sub>20</sub>, used as standard compound, were taken from Viton et al.<sup>4</sup> and from the results presented in Table 1. The experimental data of n-C<sub>24</sub> are reported in Table 2. The sublimation, vaporization and melting enthalpies determined as previously are respectively 167.3 kJ.mol<sup>-1</sup>, 105.0 kJ.mol<sup>-1</sup> and 62.3 kJ.mol<sup>-1</sup>. The temperature at the triple point is 324.0 K and the pressure is 0.00160 Pa.

**Table 2. Vapor pressure of n-C<sub>24</sub>**

	T /K	P /Pa
Solid state	307.74	$5.89 \times 10^{-5}$
	312.83	$1.78 \times 10^{-4}$
	317.93	$4.79 \times 10^{-4}$
	322.94	$1.23 \times 10^{-3}$
Liquid state	333.09	$4.58 \times 10^{-3}$
	353.20	$4.07 \times 10^{-2}$
	373.13	$2.68 \times 10^{-1}$

### *Vapor pressure of n-C<sub>28</sub>*

The vapor pressures of the standard compound n-C<sub>24</sub> are taken from Mokbel et al.<sup>6</sup> The experimental values of n-C<sub>28</sub> are reported in Table 3. The sublimation, vaporization and melting enthalpies are respectively 196.3 kJ.mol<sup>-1</sup>, 117.8 kJ.mol<sup>-1</sup> and 78.2 kJ.mol<sup>-1</sup>. The temperature at the triple point is found to be 339.1 K and the pressure is 0.000371 Pa.

**Table 3. Vapor pressure of n-C<sub>28</sub>**

	T /K	P /Pa
Solid state	323.05	$1.17 \times 10^{-5}$
	329.02	$4.39 \times 10^{-5}$
Liquid state	339.02	$3.58 \times 10^{-4}$
	352.98	$1.86 \times 10^{-3}$
	372.85	$1.76 \times 10^{-2}$
	392.76	$1.14 \times 10^{-1}$
	412.72	$6.06 \times 10^{-1}$

The determined vapor and sublimation pressures of the three alkanes were fitted to the Clausius-Clapeyron equation and represented in Figure 2.

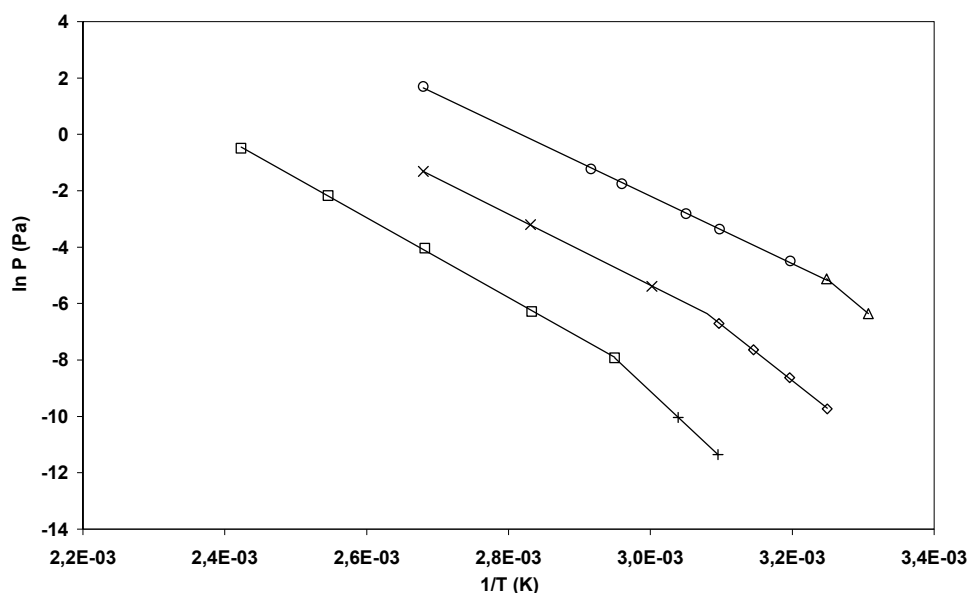

**Figure 2.** Plots of  $\ln P$  against  $1/T$  for n-C<sub>20</sub>, n-C<sub>24</sub> and n-C<sub>28</sub>.  $\Delta$ , C<sub>20</sub> solid state;  $\circ$ , C<sub>20</sub> liquid state;  $\diamond$ , C<sub>24</sub> solid state;  $\times$ , C<sub>24</sub> liquid state;  $+$ , C<sub>28</sub> solid state;  $\square$ , C<sub>28</sub> liquid state

#### ***Uncertainty on the vapor and sublimation pressures.***

Knowing that the uncertainty on the flow rate of the saturation gas is 1% and the relative uncertainty of the area ratio is 3%,<sup>6</sup> we deduced from equation 1 the relative uncertainty on the pressure ratio which is about 4%. If the standard compound is known with a good accuracy (suppose 1%), the relative uncertainty on the vapor or sublimation pressure of the sample is about 5%.

#### **Conclusion**

Sublimation and vaporization pressures of three n-alkanes were determined by means of the gas saturation technique. From the experimental vapor and sublimation pressures were deduced sublimation, vaporization, and melting enthalpies. The obtained enthalpies are in a quite good agreement with the available literature data.

Thus, the apparatus in its relative version beside equilibrium determination, permits reliable vapor and sublimation pressures in a wide range:  $10^{-5}$  Pa to 100 Pa. With this method one can monitor the eventual thermal decomposition of the studied compound.

#### ***References***

- (1) Chirico R.D.; Nguyen A.; Steele W.V.; Strube M.N. Vapour pressure of n-alkanes revised. New high-precision vapour pressure data on n-Decane, n-Eicosane, and n-octosane. *J.Chem. Eng. Data* **1989**, *34*, 149-156.
- (2) Morgan D. L.; Kobayashi R. *Fluid Phase Equilib.* **1994**, *97*, 211-242 Direct vapor pressure measurements of ten n-alkanes in the C10-C28 range.
- (3) Viton C. Phd Thesis Université Claude Bernard Lyon 1 **1995**
- (4) Viton C.; Chavret M.; Behar E.; Jose J. Vapor pressure of normal alkanes from decane to eicosane at temperatures from 244 K to 469K and pressures from 0.4 Pa to 164 kPa. *Int. Electron. J. Phys.-Chem. Data* **1996**, *2*, 215-224.

- (5) Terufat S.; Mokbel I.; Ainous N.; Rauzy E.; Berro C.; Jose J. Experimental Vapor Pressures of Six n- Alkanes (C21, C23, C25, C27, C29, C30) in the Temperature Range between 350 K and 460 K. *J. Chem. Eng. Data* **2006**, *51*, 854-858.
- (6) Mokbel I.; Razzouk A.; Hajjaji A.; Msakni N.; Jose J. A gas saturation apparatus for very low vapor or sublimation pressure measurements ( $10^{-3}$  Pa): vapor-liquid equilibria of n-alkanes (n-C10, n-C24,n-C28). *J. Chem. Eng. Data* **2007**, *52*, 1720-1725
- (7) Razzouk A.; Mokbel I.; Garcia J.; Fernandez J.; Msakni N.; Jose J. Vapor pressure measurements in the range  $10^{-5}$  Pa to 1 Pa of four pentaerythritol esters. Density and vapor-liquid equilibria modeling of ester lubricants. *J. Fluid Phase Equilib.* **2007**, *260*, 248-261
- (8) Ruzicka K.; Mayer V. Simultaneous treatment of vapor pressures and related thermal data between the triple and normal boiling temperatures for n-alkanes C<sub>5</sub>-C<sub>20</sub>. *J. Phys. Chem. Data*, **1994**, *23*, 11-39
- (9) Pouillot K. F. L. L.; Chandler K.; Eckert C. A. Sublimation Pressures of n-Alkanes from C<sub>20</sub>H<sub>42</sub> to C<sub>35</sub>H<sub>72</sub> in the Temperature Range 308-348. *Ind. Eng. Chem. Res.* **1996**, *35*, 2408-2413