

Post-Viral Inactivation Filtration for Impurity Removal in Biopharmaceutical Processes

*Jeffrey E. Galvin, David Maheu & Sushil Abraham
Amgen Inc., 4000 Nelson Rd., Longmont, CO 80503*

Abstract

Viral inactivation is a critical bioprocessing step that employs chemical treatments such as pH titration or addition of surfactants to inactivate enveloped viral contaminants. A filtration step often follows the viral inactivation to reduce the turbidity that results from the chemical treatment. This paper describes the development and characterization of a post-viral inactivation filtration step for a biopharmaceutical process. In addition to reducing turbidity, the filtration step also removes impurities such as host cell proteins and nucleic acids. Although the purification process already shows sufficient capability to remove these impurities, the post-viral inactivation filtration significantly reduces the burden on downstream steps, thereby increasing overall process robustness and consistency.

Introduction

Several types of filters have been characterized for removal of turbidity resulting from neutralization of the viral inactivated pool in biopharmaceutical purification. In early development of a monoclonal antibody (MAb) purification process, it was observed that a single-stage membrane filter quickly became clogged with impurity particles, leading to the introduction of a two-stage filtration train consisting of a prefilter followed by a membrane filter. Several pre-filter types were characterized, and depth filter media was found to be the most effective pre-filter for this stream. In particular, composite filters containing both a pre-filter depth media (i.e. glass fiber or silica) followed by a membrane filter were found to provide the most robust performance in terms of throughput.

Filter characterization studies focused on identifying the filter area required to complete the filtration in a reasonable processing time while avoiding replacement of the filters mid-process due to high pressure drop. These studies were conducted using traditional filter sizing methods such as constant pressure (V_{max}) and constant flow (P_{max}). Additional studies looked at the ability of the two-stage filtration train to remove turbidity as well as reduce process impurities such as DNA, host cell (Chinese hamster ovary) proteins (CHOP), and high molecular weight species (HMWS).

One aspect of the step that has not been fully characterized is the mechanism for removal of impurities by the filtration train. Two potential mechanisms are removal of impurity particles by size exclusion and adsorption of impurities on the surface of the filter media. The purpose of this paper is to investigate impurity removal mechanisms by comparing a characterization case study to historical data.

The case study focused on DNA and CHOP because of the importance of the VI filtration step in removing these impurities. Although about 98% of DNA in the harvest filtrate

is removed by Column 1, an additional 4-5 logs of DNA clearance is normally achieved across the VI filtration step (Figure 1). CHOP is also reduced by 1-2 logs across the step (Figure 2). Subsequent chromatography steps, however, have been shown in a worst-case study to be able to remove an additional 1-2 logs of both CHOP and DNA, adding robustness to the overall purification process.

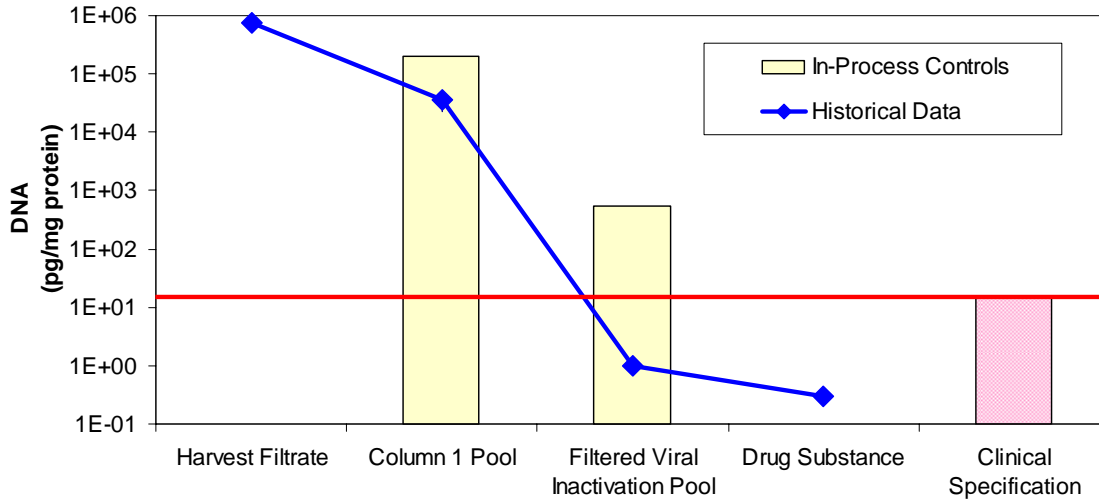

Figure 1. Process Clearance of DNA [pg/mg protein]

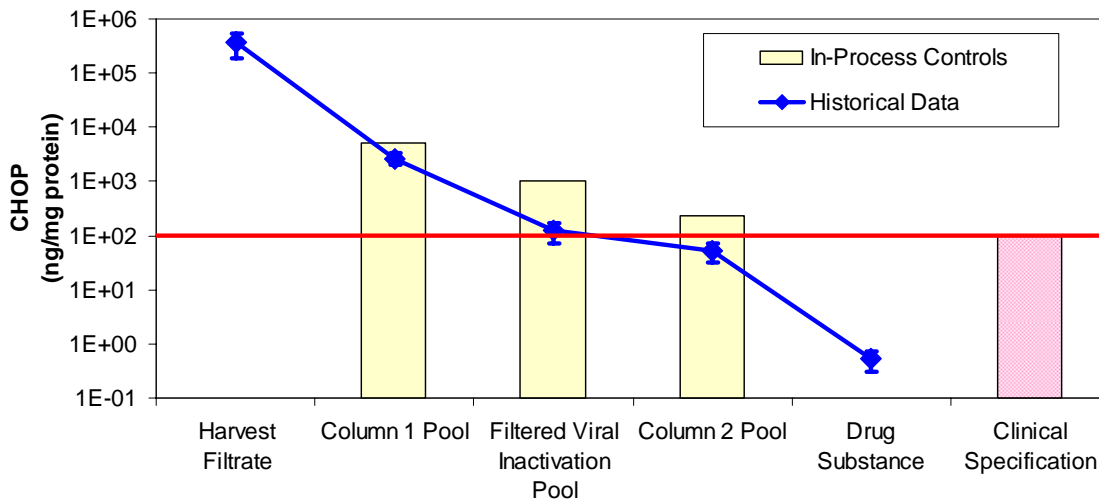

Figure 2. Process Clearance of CHOP [ng/mg protein]

Materials and Methods

Column 1 pool generated in this experiment was virally inactivated according to the process summarized in Figure 3. A buffer addition was performed after acid titration to simulate the buffer chase after transfer from titration tank to hold tank. However, in a departure from the standard process, a buffer with higher ionic strength was used for the chase dilution. The use of a higher ionic strength buffer increased the ionic strength and conductivity of the pre-filtered pool above what is normally observed.

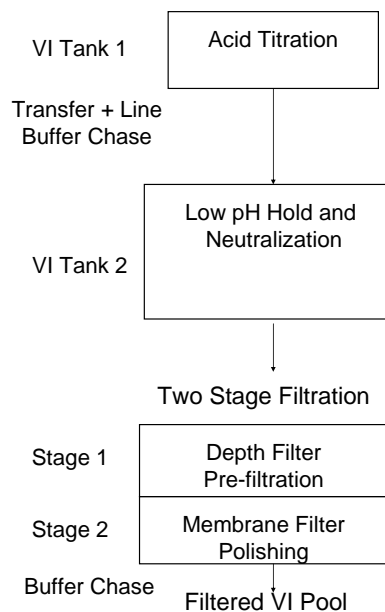

Figure 3. Viral Inactivation Process Flow Diagram

The resulting neutralized viral inactivated pool was filtered over three separate filter trains in parallel. Train 1 used a smaller version of the stage 1 depth filter, while Train 2 used a different stage 1 depth filter with similar materials of construction. Train 3 was a control. All three trains used a dual-layer membrane filter as the stage 2 filter. Flow through samples were taken every 2 liters and sent for CHOP and DNA analysis.

Results

Table 1 summarizes the post-VI filtration performance results. In all trains, CHOP and DNA (Figures 4 and 5) were significantly higher than representative historical data. Turbidity for the pre-filtered pool was lower than typically observed prior to filtration, while post-filtration turbidity was comparable (Table 1). Pool conductivity was elevated due to the use of the high ionic strength buffer in the chase step. Results from the different stage 1 filters used in Trains 1 and 2 were comparable.

Table 1 Summary of Post-VI Filtration Results vs. Historical Data

	Turbidity [NTU]		Conductivity [mS/cm]	CHOP [ng/mg]	DNA [pg/mg]
	Pre-filtration	Post-filtration (FVIP)	FVIP	FVIP	FVIP
Train 1	67.8	5.88	5.53	1529	472
Train 2		7.17	5.46	1610	304
Train 3		3.61	5.53	685	42
Historical Data mean \pm SD	189 \pm 33	1.99 \pm 0.20	2.02 \pm 0.27	290 \pm 86	<1

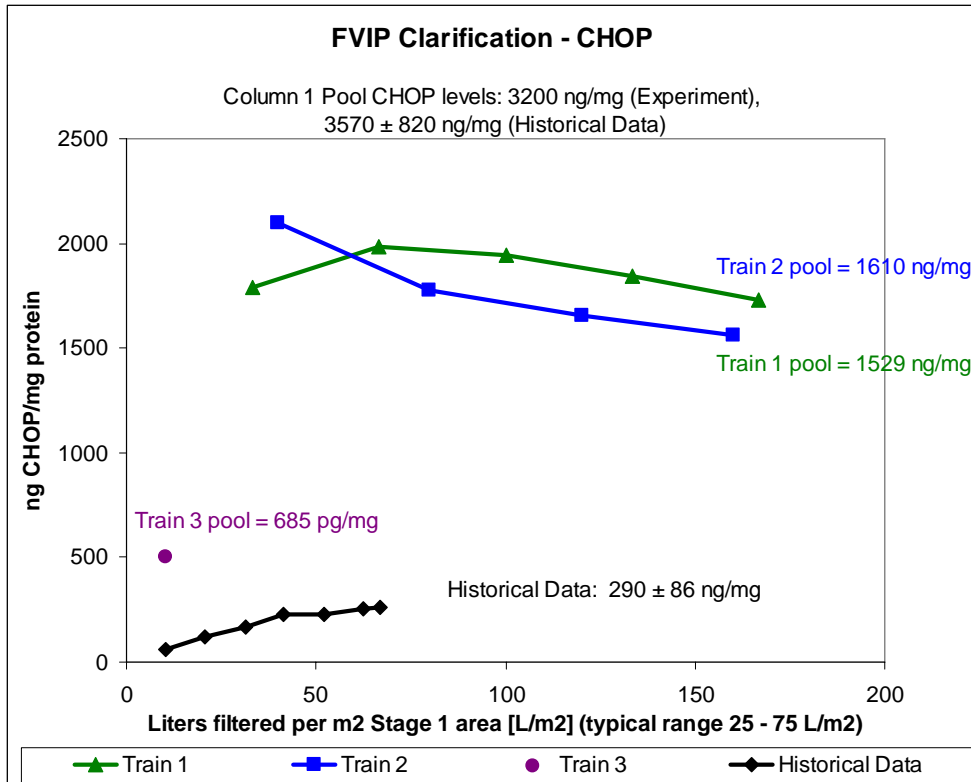

Figure 4. CHOP Flow Through for Experiment vs. Historical Data

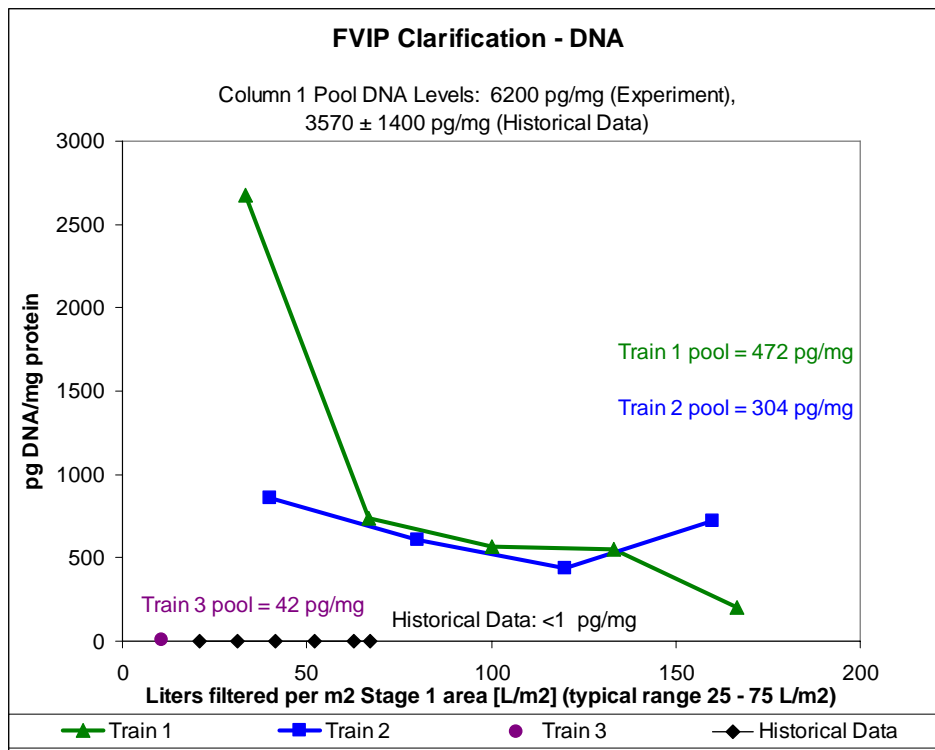

Figure 5. DNA Flow Through for Experiment vs. Historical Data

Discussion

As shown in Figures 4 and 5, removal of CHOP and DNA was much less effective in this experiment compared with historical data. Flow through sampling indicated that filter overloading was not the root cause. The pre-filtered material was less turbid (Table 1) than usual, and the pool conductivity was higher than usual. The low turbidity suggested a smaller particle size distribution, which may have reduced size exclusion removal efficiency. The high ionic strength, indicated by high conductivity, may have reduced the extent of adsorption of small impurity particles on the filter media. Ionic strength could have also impacted the extent of precipitation of impurity particles.

Although some impurity removal may be realized at this step, in general the viral inactivation clarification filter area requirement should not be based on achieving a target impurity removal. The adsorptive properties of the filters are not sufficiently controlled by the filter vendors to be considered reproducible. Therefore, the process should be developed to minimize the reliance on this step for impurity removal. For a robust biopharmaceutical process, the downstream chromatography steps should have sufficient capacity to remove elevated levels of CHOP and DNA, as is the case for this process (Tables 2 and 3).

Table 2. CHOP Levels for Downstream Steps vs. Historical Data and Worst Case Study

	CHOP [ng/mg protein]		
	FVIP	Column 2 Pool	Column 3 Pool
Experiment	1424	147	
Historical Data mean \pm SD	290 \pm 86	111 \pm 26	
Worst Case Study	72	45	< 0.52

Table 3. DNA Levels for Downstream Steps vs. Historical Data and Worst Case Study

	DNA [pg/mg protein]		
	FVIP	Column 2 Pool	Column 3 Pool
Experiment	578	91	
Historical Data	<1.22	<0.85	
Worst Case Study	554	142	< 1

Conclusions

Impurity removal in the post-viral inactivation filtration can significantly reduce the burden on downstream steps, but performance in this step can be sensitive to process conditions. However, a robust purification process will demonstrate sufficient capability to remove impurities without relying on the filtration step, therefore aligning with best practices for MAb processes.