

Building a High-Fidelity Dynamic Simulation and Control System Fast

David C. Zhou, Ph.D.
President, 2States Technology
100 Cowing Street, West Roxbury, MA 02132
David.zhou@2stastes.com

KEYWORDS

Sizing and Selection, Modeling, Steady-State and Dynamic Simulation, Control, Tuning

ABSTRACT

Process operations are dynamic in nature. It is the ultimate goal to own a high-fidelity virtual dynamic system that simulates behaviors and performance not only under normal conditions but also during startup and shutdown as well as under abnormal conditions. Such a system could be used to exam designs, analyze operations, obtain simplified models for model-based controllers, tune controllers, train operators and find optimum solutions. However, building such a system remains a challenging task.

Integrating high-fidelity equipment blocks, with built-in sizing, rating and testing methods and environment into a simulation tool would help a user achieve such a goal. Furthermore, adding product databases and selection methods to obtain equipment parameters automatically simplifies the building process for the user. Examples are included to demonstrate the application of such a tool to process industries.

INTRODUCTION

Steady-state simulation is widely used in process design. However, a high-fidelity dynamic simulation is particularly useful to design control systems, tune controllers and train operators. Furthermore, dynamic simulation may be an effective way to resolve the conflicts between optimum design from a steady-state standpoint and optimum dynamic control and operation.

It is natural to build a virtual dynamic system the same way to build a real plant, using pre-built equipment, instrument and controller blocks. You can size, select and connect these blocks together, set up initial conditions and push a button to run. These virtual blocks interact among themselves and with operators via fluid and signal to simulate an existing process or the process to be built.

A simulation platform with these blocks and an integrated environment is a useful tool

for users to build high-fidelity dynamic systems fast. With the unified platform for both steady-state and dynamic simulation, process and control engineers can work together to optimize the process and control design, size and select equipment, and tune the virtual plant to ensure the real plant can be started up quickly and run as expected.

VIRTUAL BUILDING BLOCKS

To quickly build a dynamic system, it is critical that a simulation tool is armed with pre-built model block libraries. Libraries contain blocks ranging from math, signal, system and control to process instrument and equipment such as piping, tanks, valves, pumps, heat exchangers and distillation columns for process industries.

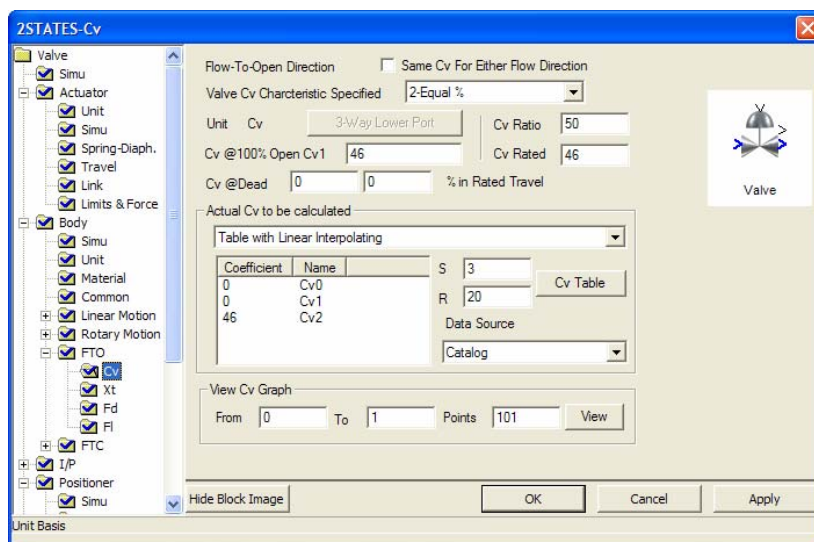

Figure 1. Components of a Pneumatic Control Valve System

For the virtual dynamic system to be accurate in a wide operation scope, building blocks should be accurately modeled, based on physical and chemical laws and rigorous math and engineering relationships that apply. However, extremely rigorous modeling should be avoided to save development work and make simulation time reasonable by a personal computer.

A general equipment block may require hundreds of parameters to be modeled accurately for most possible cases. A pneumatic control valve system shown in figure 1 consists of a valve body, an actuator and position controller with optional airset and air booster. All these components are required to be modeled accurately and interact among them and with process fluid passing through valve body to exhibit its function and behaviors.

Figure 2 shows dynamic response on 2% input step change of a control valve with high packing friction. High friction in a valve may cause stick-slip movement of valve stem and limit cycling of its control loop. Furthermore, it may prevent a valve from fully opening or closing if its actuator is not sized properly. If the control valve is oversized in capacity, high friction may significantly degrade the performance of its control system. Simulation tests with such a high-fidelity control valve modeling can reveal these problems and help find the solutions.

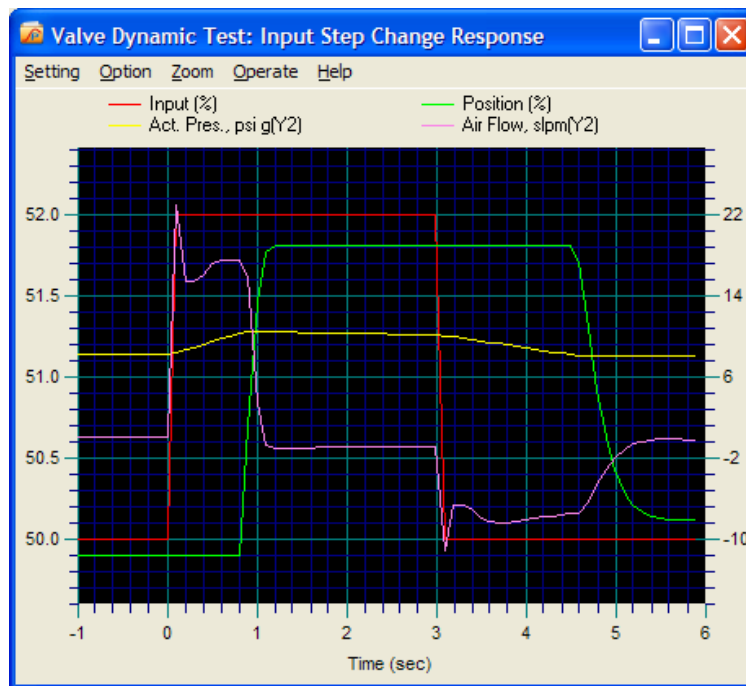

Figure 2. Dynamic Response of a High Friction Control Valve

A user may make simplification for a customized block in modeling and calculation based on his or her judgment and the task undertaken, so their impact on calculation is either negligible or unimportant for the particular task.

OBTAIN DATA BY SIZING AND SELECTING EQUIPMENT

Equipment may vary in types and sizes. For a specific application, there may be many equipment products to choose from. Sizing and selection functions in an equipment block can be used to size and select equipment and to obtain the equipment parameters from databases automatically. This alleviates burdens on users for providing data for the block and reduces development time for building steady-state and dynamic simulation systems.

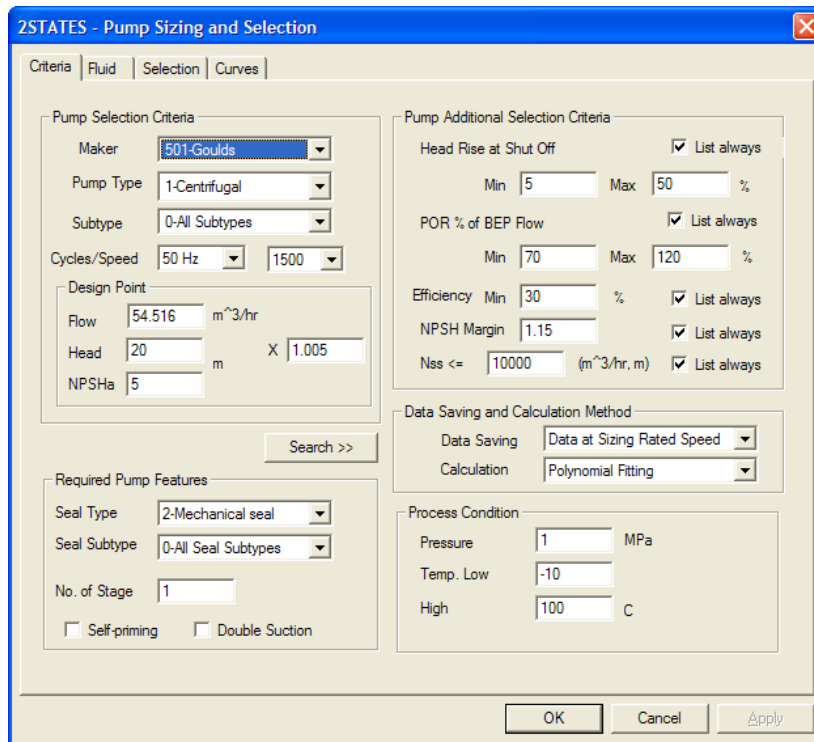

Figure 3. Pump Sizing and Selection Interface

Passing process data from upstream or related equipment for sizing downstream or auxiliary equipment may reduce data entry errors and increase work efficiency. The same applies for rating and testing. For example, after sizing a distillation column, its reboiler and condenser can be sized, based on the results of a distillation column sizing, such as stream flow, temperature, pressure and compositions as well as thermal duties required. Similarly, pumps, control valves, flow measuring elements and connecting pipes in the column system can also be sized consequently in the process.

Equipment sizing may produce multiple options, as illustrated in Figure 4 for heat exchanger sizing. Built-in rating and testing methods in a block can be used to evaluate the options. Various steady-state and dynamic tests can be conducted and comparisons can be made to make an informed choice. Figure 5 shows dynamic responses of three heat exchangers under consideration. Of course, important equipment should be further evaluated from steady-state and dynamic simulation tests of its loop-wide, unit-wide even plant-wide systems to determine if the selection is the best.

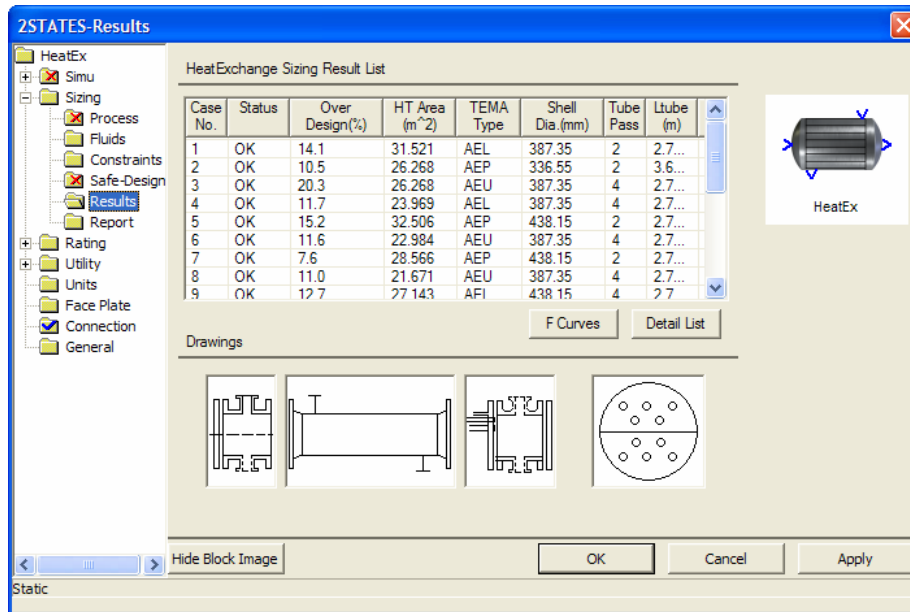

Figure 4. Multiple Options after Heat Exchanger Sizing

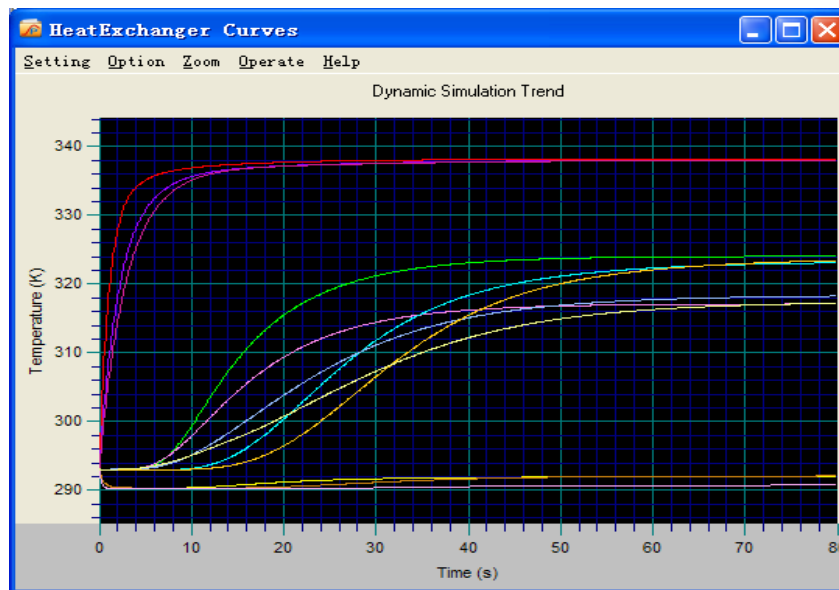

Figure 5. Dynamic Responses of Three Heat Exchangers

FLUID PROPERTY CALCULATION

Process equipment is typically used to process fluids. Setting up fluids in applicable blocks and choosing the appropriate fluid property models and methods are important in equipment sizing and rating as well as steady-state and dynamic simulation. Fluid property models and methods are used to calculate thermodynamic and transport properties such as density, viscosity, thermal conductivity, fugacity, enthalpy and

entropy. Therefore they contribute to the accuracy of calculation results as long as fluid is involved.

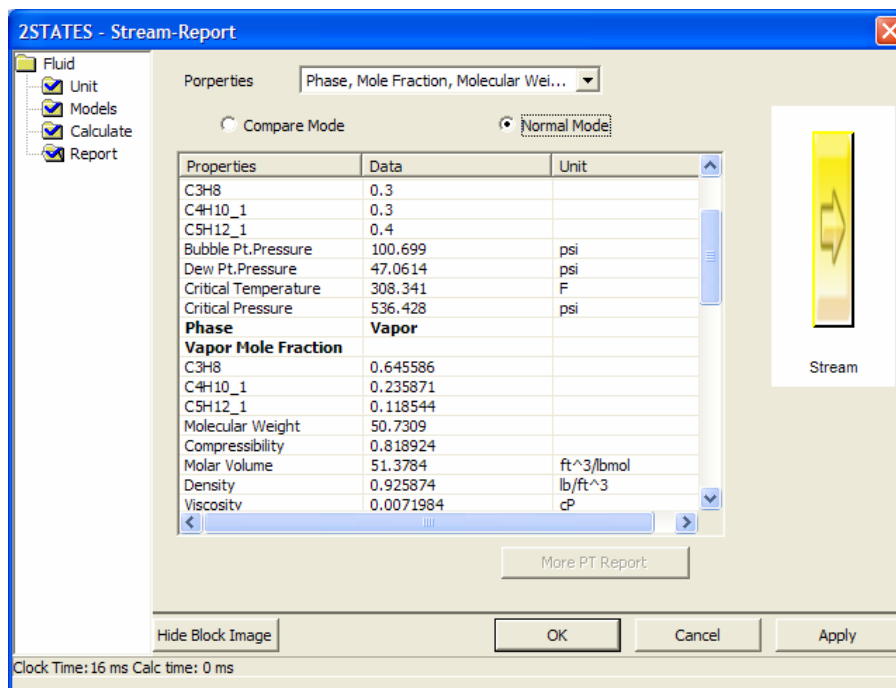

Figure 6. Property Calculation Results of a Fluid Mixture

BUILDING AND SIMULATING A PROCESS

Simulating a process is useful in research, design, operation and training. The block based simulation structure and graphic interface make the building and modify a process easy. To build a process, select the blocks needed and connect the blocks with wires. Rigorous modeling of individual blocks and fluid property calculation combining integration methods allow simulating behaviors and performance of a process not only under normal operating conditions but also during startup, shutdown, and under abnormal conditions. That would help find optimum process and control structures and strategies, minimize energy consumption and obtain controller tuning parameters that applicable to various operating conditions.

With such a simulation tool, you can interactively modify equipment data, operating conditions such as temperature and pressure, feed compositions and controller parameters during the simulation or to run new cases and evaluate alternatives. You can monitor the operation through faceplates, data views, trends, graphs, tables and other interfaces that are configurable and adjustable and can be opened or closed at any time.

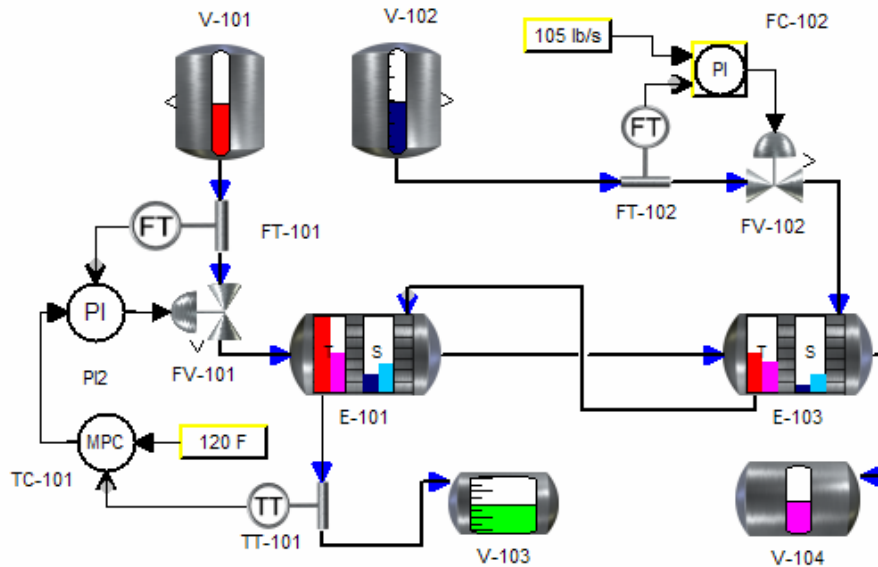

Figure 7. Temperature Control Simulation of Heat Exchangers in Series

Figure 7 gives a simulation diagram for two heat exchangers in series. It may demonstrate how different dynamic behaviors become when flow load changes. You can tune controller parameters to see its impact on dynamic performance under different operation conditions. You can compare model predictive control (MPC) against PID control side by side for this particular application to arrive at your conclusion.

A distillation column (Figure 8) is an important process and a good example for multivariable control system design and simulation. High-fidelity dynamic column simulation allows a user to develop its control system and test it under a wide operating condition. You can identify a simplified model for model predictive control and evaluate its performance under manipulated operating conditions.

After the control method is finalized, the system may be used for operator training. A high-fidelity simulation system is much more valuable than a simulator with simplified models, because it can train operators to run the process under much wider operating conditions, especially abnormal ones.

If there are operating data available, you can refine data such as fouling resistances for heat transfer and column tray efficiencies for separation to match simulation results with actual process data. The virtual system can be used to trouble-shoot existing process and control problems, optimize plant operation and study modification of processes and procedures.

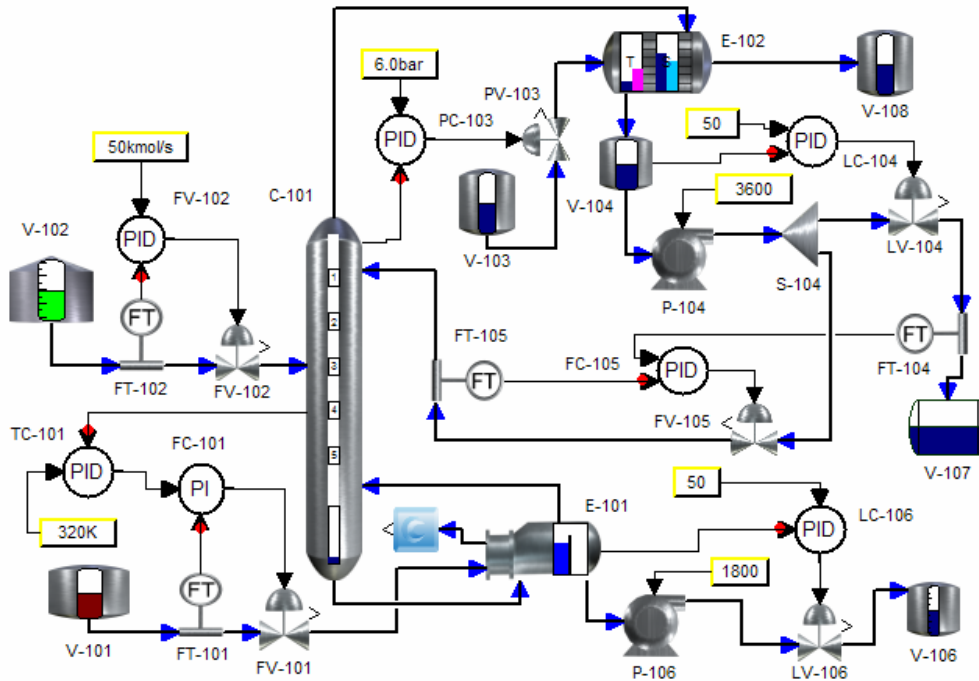

Figure 8. Distillation Column Dynamic Simulation

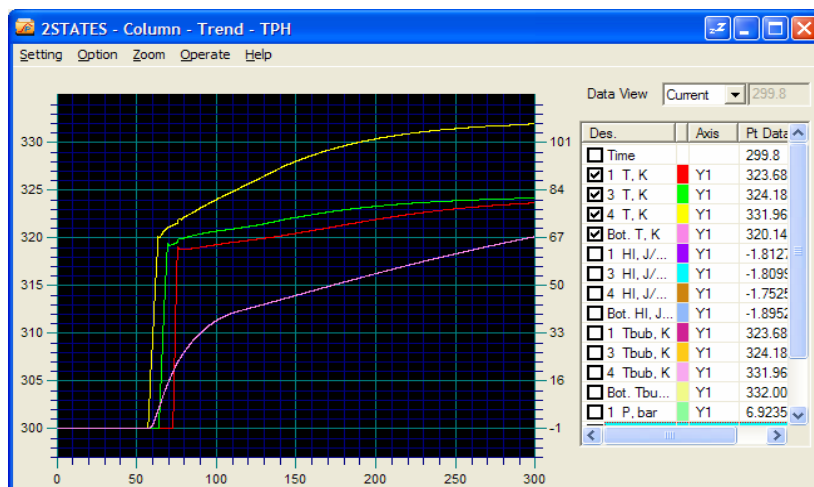

Figure 9. Temperature Response during Distillation Column Startup

SUMMARY

It is possible to quickly build a high-fidelity dynamic simulation system for wide operating ranges with a simulation tool. It is essential such a tool is created with various accurate blocks and sizing and selecting functions to obtain data from built-in databases. In the near future, high-fidelity dynamic plant simulation would be widely used in design, troubleshooting and training, thus become a valuable tool to own.