

# Simulation and optimization of the process used in Colombia for the production of Biodiesel from palm oil: a kinetic analysis and an economical approach

F. Velosa<sup>‡</sup>, J.M. Gomez<sup>†‡</sup>.

*Los Andes University, Carrera 1 N° 18A 10 Bogotá, (Colombia)*

*<sup>‡</sup>Chemical Engineering Department*

---

Colombia, as a developing agricultural country interested on the progress of the biofuel industry, has acknowledged the oil market juncture, creating a legal frame to become one of the main biofuel players in the region. As palm growers and the industry invest on the developing business, the academy develops technical and economical tools that allow a promising start.

A simulation and optimization of the process used in Colombia for the production of Biodiesel from palm oil under homogenous alkali catalysis was developed. Biodiesel production was chosen as the objective function, obtaining a purity of 99.8 wt% according to the specifications established, as minimum conditions, by the ASTM D 6751 standard (99.6 wt%). Biodiesel and glycerin yields, as well as the water flow rate were found to be the most significant factors affecting the objective function. The production increment, compared with the base case (kg/hr) using numeric optimization was 5%, and the concentration of the glycerin as a result of the simulation, was high enough to sell it as a commodity product (99.4 wt%), accomplishing a more profitable production process.

*Key Words: Palm oil, homogenous alkali catalysis, simulation and optimization.*

---

## 1 Introduction

There are many cases throughout history that have shown the special value of using vegetable or waste oils in order to produce a renewable diesel fuel.

The first example came from a Belgian patent written by G. Chavane on August 31, 1937, which describes the use and production of palm oil ethyl esters as diesel fuel. During the 1930's and 1940's vegetable oils were used as diesel fuels from time to time, but usually only on emergency situations.

Another great example was when the United States developed a great concern, in the years after World War II, about the rising use of petroleum fuels and the possibility of resultant fuel shortages, developing what at the time was called a dual fuel project, involving institutions as The Ohio State University and Georgia Institute of Technology [1, 2].

At present, the instability and high oil prices, the decreased sources of fossil oil and the implementation of

Kyoto Protocol to limit the greenhouse emissions, have

been an inspiration to focus on vegetable oils and animal fats to produce biofuels [3]. The environmental aspect has received more attention since the clean developed mechanism was introduced on the global change negotiation in Kyoto. This is only a mechanism by which industrialized countries rely on the developing ones for contribution, accomplishing the weather stability [4].

Colombia, as a developing agricultural country interested on the progress of biofuel industry, has acknowledged this unique opportunity, and through the National Government has developed and implemented laws that regulate these sources of energy. The law 939 (December 30<sup>th</sup>, 2004) has established that diesel fuel, by August of the present year, has to be B05 which means that the content of biodiesel will be 5%. In other words, the demand conditions and the selling price are going to be determined by the legislation, establishing biofuels as a key element on the future of the country.

Recently, the world has shown a special interest on alternative energy sources, related to the imminent possibility of petroleum extinction; one of the oil substitutes analyzed is biodiesel, an important player on the Colom-

---

<sup>†</sup> To whom correspondence should be addressed. Tel.: +571 3393939  
Ext.: 3744. Fax: +571 3324334. e-mail: jorgomez@uniandes.edu.co.

bian territory since this country has experienced in the past years an increase on diesel fuel consumption. During 2001, Colombia used 59,915 barrels/day; meanwhile, throughout 2005 consumed 81,800 barrels/day, experiencing a 36.5% growth in four years [5].

In addition, the palm oil production during 2001 was 10.718 barrels/day, from which 27% was destined to export, mainly to Europe, 68% was used for national consumption [6] and the additional 5% was available for the development of the biodiesel industry. Therefore, if the legislation had been implemented during 2001, the available palm oil could have only covered 18% of the demand of biodiesel, and during 2005, this value would have decreased to 10% [7]. Therefore, Colombia has a long way to go in order to be able to accomplish the projections stipulated for the third trimester of this year, and it will need an enormous support by the community and the government to achieve this process objective.

Considering the technology implemented in this country, the overall Colombian panorama results in a very interesting challenge for the national industry, as well as an opportunity to develop a solid case of study focused on the simulation and optimization of a biodiesel production mill using palm oil as raw material. At this specific point, it is important to mention that even though production industry is very recent, it is essential to employ computational tools, as the commercial software Aspen Plus®, since this software offers the possibility to: analyze the viability of the project in order to know the optimum operation conditions, evaluate particular cases of study, augment the knowledge of the process, and it could also be used as an alternative tool for training, as well as many other benefits that investors, engineers and workers can have.

Most of the recent studies about the Biodiesel production using basic catalysts are focused either on specific features of one of the individual processes necessary to develop a production mill, or they have been approaching the generalities and theoretical description of the global production system. Zhang et. al. (2003), as the base case of study, have done a technical and economical evaluation of the Biodiesel production process using basic (NaOH) as well as acid ( $H_2SO_4$ ) catalysts. This research was approached by means of the simulation practice, using the commercial software HYSYS® Plant Net developed by Hyprotech Ltd., with the purpose of designing a complete and continuous process of the plant. The economic assessment took place simultaneously, identifying the aspects that had a strong influence on the financial viability of Fatty Acid Methyl Esters (FAME) production process.

Zhang et. al. (2003) presented an evaluation based in four different continuous process flowsheets for biodiesel production from virgin vegetable oil or waste cooking oil

under alkaline or acidic conditions on a commercial scale. This case of study was divided in two; the first part presented a comparison of these four processes from a technological point of view. The results demonstrate that the production of FAME from waste cooking oil, by means of acidic catalyst is a competitive alternative to be considered. Furthermore, in the second part of this work an economic evaluation of the viability of those four processes was done, identifying the most representative financial factors.

In a previous study three different simulations were conducted to identify the operational conditions that adapt to the needs of the market and the circumstances of the environment (Velosa et. al., 2007). In the next paragraphs a discussion will be effectuated around the kinetic analysis and economical factors surrounding biodiesel production. In order to improve the simulation and optimization of the process used in Colombia for the production of biodiesel from palm oil.

The relationship between the technical concepts and the economical factors is decisive when a project is evaluated, since those two perspectives are directly involved on its viability. A project's economical evaluation is a great complement to a technical approach, since it reduces the limitations between the academic exercise and reality, as well as allows a starting point for the election of the variables to be optimized.

The present article focuses on the biodiesel production optimization using an analysis of the process in order to determine the variables that assure the efficiency of the production mill, in addition to a rigorous analysis of transesterification kinetics. Furthermore, a cost estimate has been presented as an evaluation of the fixed investment cost necessary for the construction of a biodiesel production plant, in order to add an economical point of view to the technical approach that this study has to offer. It is important to mention, that along with all the advantages that the simulation software includes, it also has limitations related with its ability to model reality.

## **2 Background**

### **2.1 Economic Studies**

In the past few years, a number of papers have been written developing the economical cost analysis of biodiesel production mills. These publications focus on the economic assessment to determine the process viability and the advantages that each technology has over others [9, 11, 12].

Currently, the high cost of Biodiesel compared to the diesel fuel obtained by mineral sources, is one of the

main impediments for its commercialization. It costs near 1.5 times more than the combustible based on petroleum. Between 60 and 75% of the cost of production is related to the cost of raw material [2, 8, 11]. While in Colombia the industry of palm oil finds a position on the global market and tries to generate a positive commercial balance as an export; the prices of growth, harvest, transportation and extraction have been above those of the main producers of palm oil worldwide, Malaysia and Indonesia [6].

Among the examined plant system variables: plant capacity, feedstock price, glycerin and biodiesel yields were found to be the most significant variables affecting the economic viability of Biodiesel manufacture. It is important to mention that these studies were also based on the work developed by Zhang et. al. (2003).

## 2.2 Triglyceride Transesterification

In general, this reaction takes place with a basic or acid catalyst. Basic catalysts are the most commonly used, mainly because the reaction is faster and the operation conditions are moderate [13].

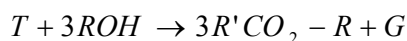

Figure 1 Overall Scheme of the Triglyceride Transesterification.

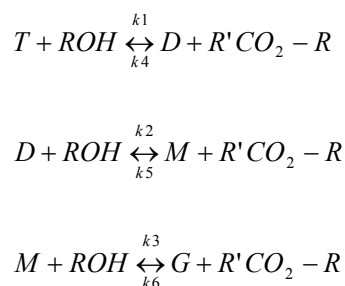

Figure 2 Triglyceride Transesterification Reaction Scheme.

Transesterification, also called alcoholysis, involves the substitution of the alkyl group of the ester by another through the interaction between the ester and the alcohol. In other words, one of the carbon chains of the triglyceride is substituted by the OH group of the alcohol that reacts with it, to form the ester (Biodiesel). However, if the selected alcohol is methanol, the reaction could be called methanolysis. The vegetable oil methanolysis yields fatty acid methyl esters and glycerol; the first ones are excellent substitutes of diesel fuel [14].

Among the alcohols that could be used in the transesterification process it is typical to find methanol, ethanol, propanol and butanol. Methanol and ethanol are the most frequently used alcohols, especially methanol for its cost

and its physical and chemical advantages as: polarity and shortest chain, being able to react in short periods of time with triglycerides and NaOH [2].

Moreover, most of the ethanol produced in Colombia has been assigned to the biofuel industry. It is blended with regular fuel in order to diminish the dependence on oil derived fuels among some other reasons.

Methanolysis would proceed at standard temperature (21 °C) with a reaction time of 4 to 8 hours. The reaction time could be diminished to 1 or 2 hours rising the temperature up to 60 °C [12, 15, 16]. Lower operation temperatures suggest lower energy consumption and a decrease in investment costs, but the raw material has to have a higher purity [17].

Even though this kind of system holds great benefits in terms of time of reaction, it has a very particular limitation which is the purity of the raw material. The production of esters by means of basic accelerant agents is sensitive to the water as well as the free fatty acid content. The presence of water may cause the ester saponification under basic conditions. In contrast, the free fatty acids could react with the catalyst getting soaps and water as intermediate products. The saponification not only consumes the catalyst but causes the production of emulsions which generates problems in FAME recovery and purification [2, 9, 14].

The pretreatment of the raw material is a very important operation since it diminishes the water and free fatty acid content to less than 0,1 and 0,05 wt%, respectively, in order to obtain a high degree of purity.

The triglyceride transesterification reaction could be catalyzed by sodium hydroxide or potassium hydroxide dissolved on methanol. Even though these two types of catalyst have being used frequently among the researches through time, this precise case of study has chosen NaOH as its catalyst.

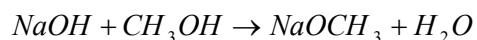

Figure 3 Reaction Scheme for the Catalyst Activation (NaOH).

Figure 3 illustrates the catalyst activation reaction, where the active catalyst structure is represented by the alkoxide which is formed in the methanolic solution [17, 18].

## 3 Process Design

Simulation is one of the tools used by chemical engineers to interpret flowsheet diagrams, identify problems and predict the process performance. The core of the analysis is the mathematical model, a set of equations that relate the process variables. Steady state simulators

as Aspen Plus® solve the unknown variables starting from specified quantities.

There are several levels of complexity involved on a project evaluation: mass and energy balances (short calculation), equipment sizing (rigorous calculation) and profitability analysis [19].

The development of this case of study was done by simulating a process using a short and rigorous calculation in order to determine the dimensions and characterization of the equipment. As a result, the objective function was built choosing the quantity of methyl oleate (biodiesel) as the variable to be optimized. It is important to mention that two cases of study were developed based on the article *Biodiesel production from waste cooking oil: 1 Process design and technological assessment*; written by Zhang et. al. (2003).

The main plant units include CSTR reactors, distillation columns and extraction columns. The materials required for the main process units are were obtained from the base case of study. Taking into account the corrosive character of sodium hydroxide, the suggested material for the reactors is stainless steel 316; for the rest of the units, carbon steel will be used [9].

Distillation is chosen as the separation process for methanol, as well as for the purification of FAME and glycerol. Even though the boiling point of methanol (65 °C at 1 atm) is lower than FAME's (approximately 320 °C at 1 atm) or glycerol (300 °C at 1 atm), simulations have suggested that the desired purities for biodiesel and glycerol (greater than 90 wt%) can not be achieved by a flash unit [10]. For this type of unit, it is assumed that the tray efficiency was 60%, in addition to a security factor of 15%.

### 3.1 Reactors (R-101 y R-101A)

Many studies of alkali catalyzed transesterification based on simulations have been elaborated; most investigated the economic feasibilities of the different technologies used to produce Biodiesel. For these articles, a conversion reactor was chosen in spite of the availability of kinetic data, for all of the different types of catalysts, in order to be able to compare the results of the selected technologies [8, 9, 10, 11, 12].

For this particular case of study, the reaction and its parameters were included, in the rigorous calculation and the optimization, to formulate a scenario that reduces to a certain point, the limitations related with the ability of the software to model reality.

The reaction was carried out at a 7: 1 molar ratio of alcohol to palm oil, since at high molar ratios the ester conversion increases as the reaction evolves faster [2]; a 1% weight catalyst concentration, which was based on

oil, (basic catalysis). This specific concentration has been justified by studies that Darnoko et. al. (2000) have made where they acknowledged that it was the optimum concentration.

The operation conditions for the reactor were fixed at 80 °C and 400 kPa, differing from the 60 °C temperature mention by Zhang et. al. (2003). The reactor pressure was established considering that methanol boiling point (65 °C a 1 atm) is an important constrain. Moreover, many studies of alkali-catalyzed transesterification have been carried out, in which a reaction temperature near the alcohol's boiling point was recommended [8, 9, 11, 14, 16]. It is critical to consider that at values bellow 100 °C the formation of soaps occurs if the purity of the raw material is not evaluated as an extremely important process variable [17]. Different Industrial approaches have shown that the values for this variable vary form 70 to 80 °C [20].

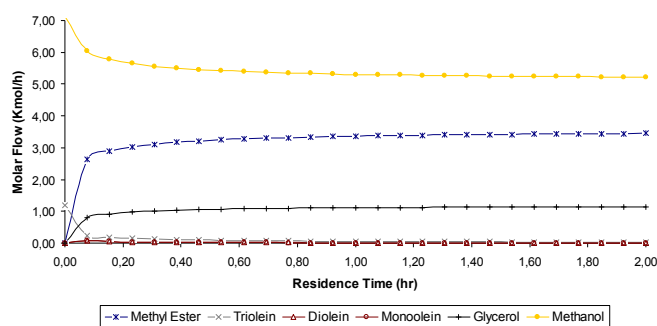

Figure 7 Flow Profile against Residence Time R-101.

Another important variable is the residence time which could be determined by means of a flow profile analysis. Figure 7 illustrates the reactants' and the products' flow profile against residence time. The results from a kinetic point of view; have a very satisfactory tendency compared with the experimentation proposed by Gemma et. al. (2005); residence time was 1.5 hours on each one of the reactors and the volume was 2.4 m<sup>3</sup>. Since an increase on the time variable would not affect the production considerably.

A series pattern was chosen for this particular case because it increases the conversion from 96.1% to 99.8%, which facilitates the separation and purification processes, making the plant more efficient. Being one of the most significant changes effectuated compared with the base case. It is important to mention that this modification represents only a 9% increase in the total capital investment.

The composition obtained, based on palm oil, for the first reactor was of 34.7% and for the second reactor it increased to 36.0%, value that reflects the importance of the improved pattern.

The reactors were assumed to operate continuously for all cases, Lab-scale conditions and reaction analysis made by Gemma et. al. (2005) for rigorous calculation and optimization were assumed to be appropriate for large scale production. The kinetics of triolein reactions are based on a reaction mechanism that includes a mass transfer-controlled region preceded by a kinetic section. Nevertheless, the mass transfer controlling segment is insignificant while using an impeller speed of 600 rpm. The result for the experiment demonstrates that the kinetic section follows a second order mechanism for the reactions, where the reaction system can be presented as a pseudo homogeneous catalyzed reaction [14]. Thus, the equations regarding the previous mentioned system are as follows:

$$\frac{dT}{dt} = -(k_1C)[T][A] + (k_2C)[E][D] \quad (1)$$

$$\frac{dD}{dt} = (k_1C)[T][A] - (k_2C)[E][D] - (k_3C)[D][A] + (k_4C)[E][M] \quad (2)$$

$$\frac{dM}{dt} = (k_3C)[D][A] - (k_4C)[E][M] - (k_5C)[M][A] + (k_6C)[E][G] \quad (3)$$

$$\frac{dE}{dt} = (k_1C)[T][A] - (k_2C)[E][D] + (k_3C)[D][A] - (k_4C)[E][M] + (k_5C)[M][A] - (k_6C)[E][G] \quad (4)$$

$$\frac{dA}{dt} = -(k_1C)[T][A] + (k_2C)[E][D] - (k_3C)[D][A] + (k_4C)[E][M] - (k_5C)[M][A] + (k_6C)[E][G] \quad (5)$$

A reaction analysis reveals that the values of the  $k_6C$  constants, corresponding to the reaction of the glycerin with the methyl ester to give monoglyceride and methanol were not significant. In other words, the reaction was not favored mainly because of the immiscibility of methyl esters and glycerol, which involved a great mass transfer resistance in that direction [14, 16].

An alternative for low methanol consumption is the implementation of a simultaneous reaction and separation system for the formed glycerol, which could be done by a selective membrane [17]. Unfortunately, when the glycerin is removed a big quantity of catalyst will be also removed; therefore, it is necessary to add extra catalyst and methanol to the second CSTR reactor [18]. This type of equilibrium based system is used by the national industry in order to diminish costs since there is no methanol production in the country.

It is important to evaluate the financial effect of this type of upgrades since it is necessary to invest in two membranes, instead of one methanol recovery system. In other words, it is appropriate to balance the economical implications that have two membrane reactors instead of a low methanol flow on stream 101. A lower capital cost could be represented by the system proposed on this article, suggesting a multi-stage column for methanol separation, in order to incorporate it into the reaction system.

### 3.2 Water washing (T-301)

The purpose of this step is to separate FAME from glycerol, methanol and the catalyst, by means of a washing column with four equivalent theoretical stages. It is essential to point out that this specific unit uses the UNIFAC-Dortmund thermodynamical model, introduced by Weidlich and Gmehling in order to overcome the disadvantages of the UNIFAC model, such as the short temperature range (10 - 40 °C) and the unsatisfactory result for the activity coefficient prediction; for those systems where different sized molecules are involved. In addition, the predictions for the behavior of systems that have alcohol are in some opportunities also incorrect [9, 21].

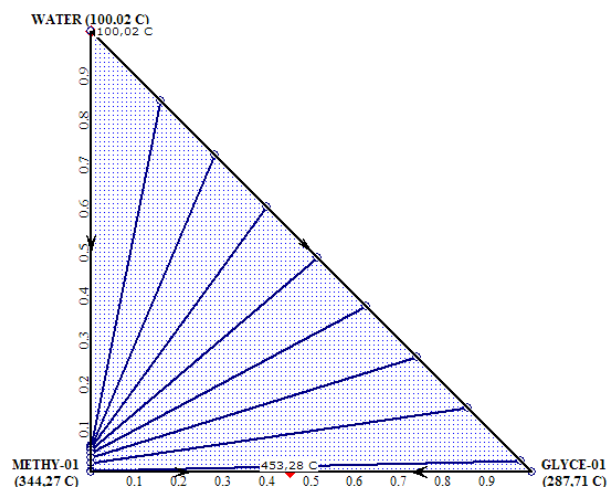
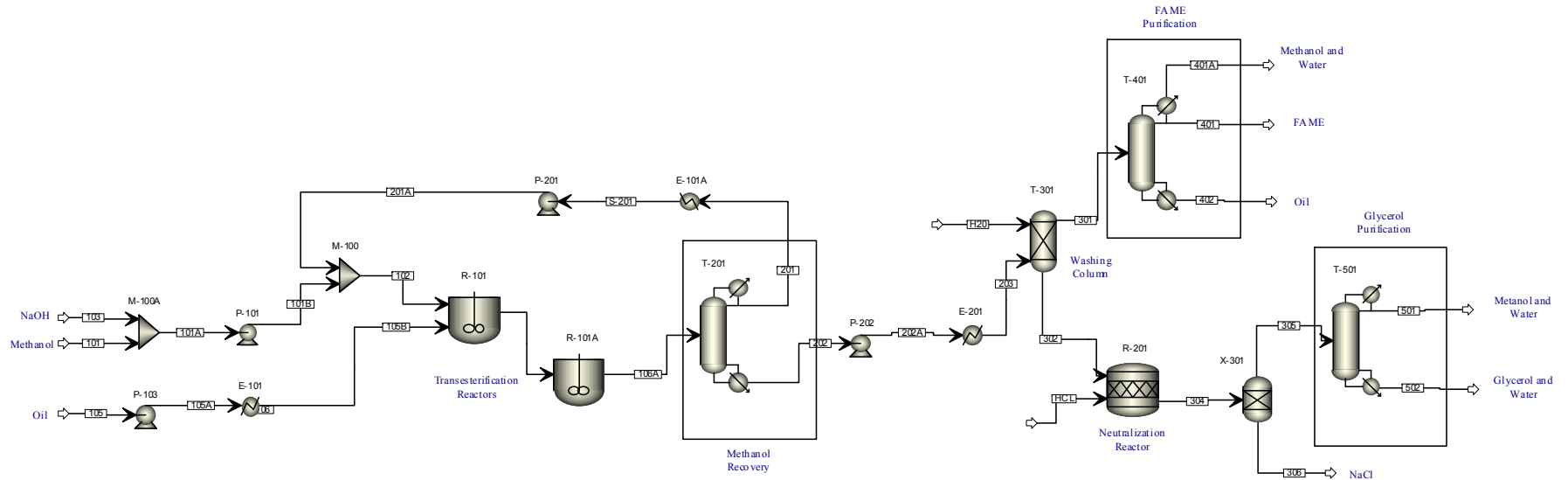

Figure 6 Ternary Map for the Washing Column T-301.

For this type of operations, it is recommended to use soft water to avoid the potential mineral transfer (calcium, magnesium and iron) to biodiesel. The temperature recommended to obtain satisfactory values of glycerin removal is 60 °C [18].

The previous work did not incorporate sodium hydroxide, as one of the raw material stream, because the parameters established by the UNIFAC-Dortmund thermodynamical model for this reactant were not available. For this work a more advanced Aspen Plus® version was

used in order to simulate the production plant including the catalyst, from the beginning of the process.



Streams	101	102	105	106.A	201	202	203	301	302	304	305	306	401	401A	402	501	502
Temperature C	25,00	24,23	50,00	80,00	28,34	78,54	60,00	57,96	58,63	60,00	60,00	60,00	193,70	193,70	257,56	50,53	136,91
Pressure atm	0,99	3,95	0,99	3,95	0,20	0,20	1,97	1,09	1,09	1,09	1,09	1,09	0,10	0,10	0,10	0,49	0,49
Vapor Fraction	0,00	0,00	0,00	0,00	0,00	0,00	0,00	0,00	0,00	0,00	0,00	0,01	0,00	1,00	0,00	0,00	0,00
Mole Flow kmol/hr	5,20	8,67	1,19	9,86	3,47	6,39	6,39	4,05	2,94	3,44	3,19	0,26	2,85	0,53	0,67	1,67	1,52
Mass Flow kg/hr	166,62	277,81	1050,00	1327,81	111,19	1216,62	1216,62	1067,91	159,71	178,83	164,11	14,72	842,22	26,45	199,24	48,92	115,19
Volume Flow l/min	3,48	5,79	66,64	26,42	2,33	24,09	23,71	21,06	2,41	2,52	2,49	1,06	18,77	3452,80	4,79	1,04	1,61
Enthalpy MMBtu/hr	-1,18	-1,96	-2,06	-4,21	-0,78	-3,45	-3,49	-2,50	-1,15	-1,30	-1,22	-0,08	-1,67	-0,12	-0,36	-0,39	-0,81
Component Mass Fraction																	
Methanol	1,000	1,000	0,000	0,124	1,000	0,043	0,043	0,009	0,272	0,243	0,265	0,000	0,000	0,351	0,000	0,881	0,003
Triolein	0,000	0,000	1,000	0,001	0,000	0,001	0,001	0,002	0,000	0,000	0,000	0,000	0,001	0,001	0,006	0,000	0,000
FAME	0,000	0,000	0,000	0,793	0,000	0,865	0,865	0,986	0,000	0,000	0,000	0,000	0,999	0,513	0,993	0,000	0,000
Dioclein	0,000	0,000	0,000	0,000	0,000	0,000	0,000	0,000	0,000	0,000	0,000	0,000	0,000	0,000	0,001	0,000	0,000
Monoolein	0,000	0,000	0,000	0,000	0,000	0,000	0,000	0,000	0,000	0,000	0,000	0,000	0,000	0,000	0,000	0,000	0,000
Glycerol	0,000	0,000	0,000	0,082	0,000	0,090	0,090	0,000	0,682	0,609	0,664	0,001	0,000	0,000	0,000	0,000	0,946
Sodium Hydroxide	0,000	0,000	0,000	0,000	0,000	0,000	0,000	0,000	0,000	0,001	0,000	0,014	0,000	0,000	0,000	0,000	0,000
Water	0,000	0,000	0,000	0,000	0,000	0,000	0,000	0,003	0,046	0,065	0,071	0,000	0,000	0,135	0,000	0,119	0,051
Hydrogen Chloride	0,000	0,000	0,000	0,000	0,000	0,000	0,000	0,000	0,000	0,001	0,000	0,012	0,000	0,000	0,000	0,000	0,000
Sodium Chloride	0,000	0,000	0,000	0,000	0,000	0,000	0,000	0,000	0,000	0,080	0,000	0,973	0,000	0,000	0,000	0,000	0,000

Figure 4 Flowsheets of the Process used in Colombia for the Production of Biodiesel from Palm Oil (Rigorous Calculation).

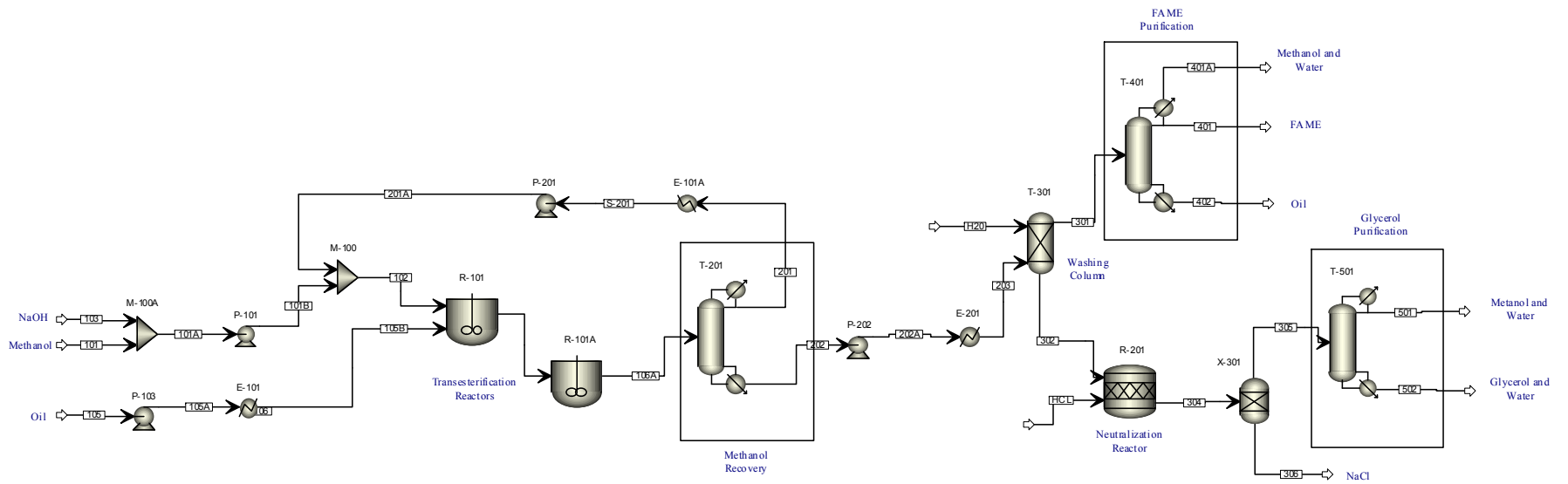

Streams	101	102	105	106A	201	202	203	301	302	304	305	306	401	401A	402	501	502
Temperature C	25,00	23,34	50,00	80,00	33,30	262,28	60,00	58,10	59,38	60,00	60,00	60,00	193,70	193,70	619,48	28,86	74,92
Pressure atm	0,99	3,95	0,99	3,95	0,20	0,20	1,97	1,09	1,09	1,09	1,09	1,09	0,10	0,10	0,10	0,04	0,04
Vapor Fraction	0,00	0,00	0,00	0,00	0,00	0,00	0,00	0,00	0,00	0,00	0,00	0,05	0,00	1,00	0,00	0,00	0,00
Mole Flow kmol/hr	3,43	7,15	1,19	8,34	3,47	4,87	4,87	3,71	1,77	2,02	1,77	0,25	3,48	0,21	0,01	0,38	1,38
Mass Flow kg/hr	110,00	283,08	1050,00	1333,08	163,08	1170,00	1170,00	1059,21	121,72	130,84	116,40	14,44	1048,62	9,08	1,50	6,88	109,52
Volume Flow l/min	2,30	5,09	66,64	26,96	2,69	28,80	23,98	21,53	1,77	1,64	1,55	5,97	23,95	1369,97	0,04	0,12	1,46
Enthalpy MMBtu/hr	-0,78	-1,97	-2,06	-4,22	-1,13	-2,63	-3,16	-2,44	-0,88	-0,96	-0,88	-0,08	-2,07	-0,05	0,00	-0,10	-0,78
Component Mass Fraction																	
Methanol	1,000	0,685	0,000	0,063	0,515	0,000	0,000	0,000	0,000	0,000	0,000	0,000	0,000	0,000	0,000	0,000	0,000
Triolein	0,000	0,000	1,000	0,026	0,000	0,029	0,029	0,032	0,000	0,000	0,000	0,000	0,032	0,032	0,011	0,000	0,000
FAME	0,000	0,005	0,000	0,765	0,009	0,870	0,870	0,961	0,000	0,000	0,000	0,000	0,966	0,584	0,000	0,000	0,000
Diolein	0,000	0,000	0,000	0,002	0,000	0,002	0,002	0,000	0,000	0,000	0,000	0,000	0,001	0,000	0,768	0,000	0,000
Monoolein	0,000	0,000	0,000	0,000	0,000	0,000	0,000	0,001	0,000	0,000	0,000	0,000	0,001	0,000	0,000	0,000	0,000
Glycerol	0,000	0,274	0,000	0,137	0,476	0,090	0,090	0,000	0,864	0,804	0,903	0,000	0,000	0,000	0,000	0,000	0,960
Sodium Hydroxide	0,000	0,035	0,000	0,008	0,000	0,009	0,009	0,000	0,078	0,001	0,000	0,013	0,000	0,000	0,221	0,000	0,000
Water	0,000	0,000	0,000	0,000	0,000	0,000	0,000	0,004	0,058	0,086	0,096	0,000	0,000	0,384	0,000	1,000	0,040
Hydrogen Chloride	0,000	0,000	0,000	0,000	0,000	0,000	0,000	0,000	0,000	0,005	0,000	0,042	0,000	0,000	0,000	0,000	0,000
Sodium Chloride	0,000	0,000	0,000	0,000	0,000	0,000	0,000	0,000	0,000	0,104	0,000	0,945	0,000	0,000	0,000	0,000	0,000

Figure 5 Flowsheets of the Process used in Colombia for the Production of Biodiesel from Palm Oil (Optimization).



## 4 Process Simulation

The Colombian Biodiesel demand and the acquisition of European technology that has not been proved in the country, generates an uncertainty based on the lack of information and experience on the production of alternative sources of energy, especially biodiesel. Nevertheless, this uncertainty could be minimized implementing engineering software to simulate and optimize the process, accomplishing an important technical development, in order to be one step ahead of an industry that represents the future of alternative fuels.

Despite the differences between the academic exercise and reality, the simulation of the biodiesel production process using sodium hydroxide as catalyst was performed employing the process simulation software Aspen Plus®, because of its complete compound library, thermodynamic packages, as well as its industrial worldwide recognition.

The process simulation procedures involved essentially: the definition of the compounds, selection of the thermodynamic model, determination of plant capacity, units and operation conditions.

The plant capacity was defined as one of the main parameters in order to establish the comparative procedure necessary to develop this work. This article chose the palm oil inlet 1050 kg/hr as the reference point; because this would allow the authors to define the production as the variable to be optimized.

Palm oil was chosen as raw material since it represents one of the most important sources of vegetable oil of the Colombian industry. In this particular case the molecule implemented in the simulation process was Triolein ( $C_{57}H_{104}O_6$ ), given that it constitutes 40.5% of palm oil. Moreover, the catalyst was sodium hydroxide and the alcohol was methanol. Consequently, Methyl Oleate ( $C_{19}H_{36}O_2$ ) was the product of interest. Properties and structure were factors established in the software library for the majority of the compounds, in order to start up the simulation. For compound like: Triolein (T), Diolein (D) and Monolein (M), this type of parameters were not available; for this reason it was necessary the implementation of the software ChemDraw Ultra®, in order to import the structure by means of the tool *User Defined* of Aspen Plus® components menu. Using the group contribution method, the software internally calculates the properties needed to simulate this case of study.

Carlson (1996) from Aspen Technology Inc. suggests the use of NRTL (Non Random Two Liquid) and UNIQUAC (Universal Quasi-Chemical) to predict the component activity coefficients on the liquid phase, based on the presence of highly polar compounds as wa-

ter, methanol and glycerin, components with medium polarity as diolein and monolein, as well as non polar compounds as triolein and methyl oleate. Seeking for the flexibility of the case of study, NRTL was established as the main thermodynamical model. In addition, UNIQUAC was used as a support model through the tool *Referenced* located in the property menu, this was supported on three reasons: 1) UNIQUAC has two adjustable parameters while NRTL has three, 2) UNIQUAC parameters have a lower sensitivity to temperature and finally, 3) since the dependent variable of concentration is a superficial fraction and not a molar fraction, UNIQUAC is applicable to solutions that have small and big molecules [23]. In conclusion, having two complementary thermodynamical models allows the simulation to have a balance between the complexity of those models and the reliability of the results.

## 5 Optimization Problem Description

The optimum value is the solution that offers the most efficient and enhanced benefit to cost ratio in a problem or process design. Optimization is one of the most quantitative tools in the industrial decision making process.

The purpose of optimization is to find the value of the variables involved in the process that produced the best performance criteria (objective function).

It is important to systematically identify the objective function, constrains and degrees of freedom in a plant, since this will benefit and improve the design, obtaining a fast and reliable solution to problems, and an opportune as well as accurate decision making [24].

The relationship between the optimization and the economical factors is decisive when a complete analysis is preformed, since those two main approaches affect directly the viability of a project.

Economic considerations are the key driving force supporting the development of inexpensive production processes. Although, Biodiesel production total cost depends heavily upon feedstock costs, there are technological parameters that affect the plant's total manufacturing costs.

### 5.1.1 Objective function and constrains

The objective function for this case of study has been defined as the production of biodiesel, to identify the operational conditions which make the process as efficient as possible, and since it was identified as one of the most significant variables by the economical studies mentioned.

Furthermore, constrains were separated in two groups: process constrains and design constrains. Process

constraints were stipulated by the ASTM D 6751 standard, specifying the biodiesel quality regulation. Design constraints were specified by the equations of each one of the units that structure the production plant.

### 5.1.2 Degrees of freedom analysis

After the simulation process has been accomplished all the equipment variables involved in the models are calculated, although only a few of them can be manipulated by the personal that closely interact with the process [24].

As the Colombian government decided to encourage national energy sources such as biofuels for the transportation sector, and since the viability of this projects rely on the state intervention; the economical factor has to be analyzed in order to become successful in the future. In other words, as the national subsidies are diminishing, the market will start to open, and only the economical efficient plants are going to prosper.

Among the system variables of the plants examined by most of the economical publications mentioned through this article, plant capacity, price of feedstock, and glycerin and biodiesel yields, were found to be the most significant variables affecting the economic viability of biodiesel manufacture. Therefore, since plant capacity is a fixed parameter and feedstock price depends directly on the market, the distillate flow rate for the FAME production tower, the extraction solvent flow and the methanol flow rate are the controllable variables that this work is focused on.

### 5.1.3 Sequential Quadratic Programming (SQP)

This type of numerical solution method solves a programming sequence of quadratic approximations, as to resolve a non linear programming problem. The method is based on a recurrent solution which iterates by means of Newton's algorithm, with the purpose of finding the optimal solution, applying the first order necessary conditions for inequality restriction problems; this means the use of necessary as well as sufficient conditions (Kuhn – Tucker conditions, KTC), as an approximation of the Lagrangian function.

The optimization of the process used in Colombia for the production of biodiesel from palm oil is a problem that can be represented as follows [24]:

$$\text{Maximize: } f(x) \quad (6)$$

$$\text{Subjected to: } g(x) \geq b \quad (7)$$

The objective function is maximizing the biodiesel production, and the restrictions to this function, are the equations of the equipment involved in the production process. In addition to the inequality constraints due to the 99.6 wt% purity required by the FAME market.

The Lagrangian function for this problem is:

$$L(x, \lambda) = f(x) + \lambda^T (g(x) - b) \quad (8)$$

and the KTC

$$\nabla_x L = \nabla f(x) + \sum_{i=1}^m \lambda_i \nabla g_i(x) = 0 \quad (9)$$

and

$$g(x) \geq b \quad (10)$$

## 6 Results and Discussion

### 6.1 Optimization

To evaluate the influence of certain parameters with a high degree of uncertainty in a design to be optimized, Himmelblau et. al. (2001) recommends the use of a sensitivity analysis.

The sensitivity analysis in non-linear programming (NLP) is a numerical or graphical indication of how a variation of the problem variables has a repercussion on the objective function [24]. The variation for this particular case of study was chosen as 80% to 120% of the value obtained by the rigorous calculation.

#### 6.1.1 Pre optimal analysis

The objective of the pre optimal analysis is to determine the most influential parameters in the objective function. In other words this type of analysis allows the researcher to identify those aspects that have an important influence in the biodiesel production.

In the optimization's first stage, variations on process methanol flow, FAME bottoms flow rate (T-401), and the extraction solvent flow rate were performed to find the optimum operational conditions. As shown by Figure 9, the bottoms flow rate is a very sensitive variable showing a marked linear tendency with variation over the variable to be optimized.

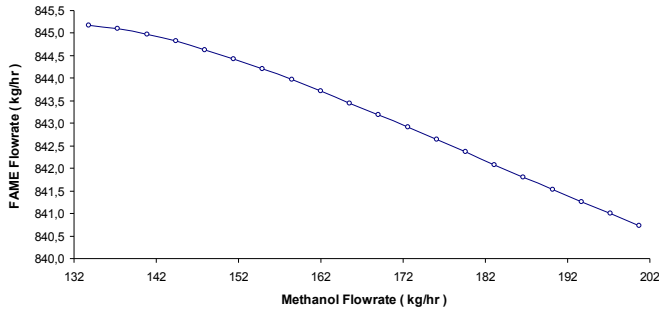

Figure 7 Sensitivity Analysis Methanol Flow rate vs. FAME Flow rate.

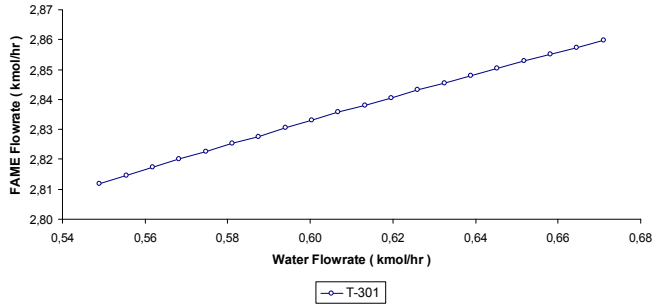
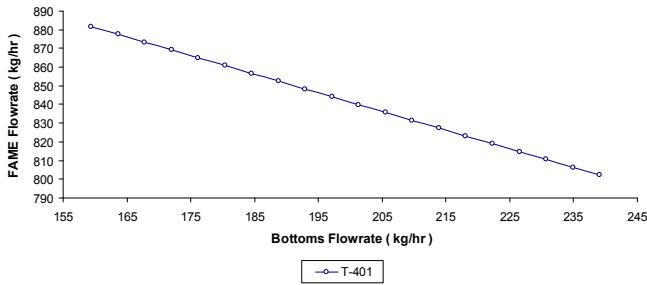

Figure 8 Sensitivity Analysis Tower T-301 Bottoms Flow rate vs.



FAME Flow rate.

Figure 9 Sensitivity Analysis Water Flow vs. FAME Flow rate.

Even though variations on the quantity of methanol affect significantly biodiesel production, the changes conducted on the extraction tower T-301 water stream, as the extraction solvent flow rate, reported important results.

### 6.1.2 Post optimal analysis

Once the optimization by means of the variation of methanol flow, the solvent extraction column and the fluctuations on the bottoms flow in the FAME purification tower were carried out; a second sensitivity analysis was implemented to determine if the values obtained by the software were local optima or global optima. In other words, if the value found is a maximum value or there are

other alternatives for better results; this idea can be illustrated by Figure 10, Figure 11 and Figure 12.

$$\text{Increase\%} = \frac{\text{Optimum} - \text{Initial}}{\text{Initial}} \times 100 \quad (7)$$

The final value for the optimization of the biodiesel production plant analyzed in this paper was 1,047.54 kg/hr. This means that one kilogram of palm oil produces approximately a kg of biodiesel.

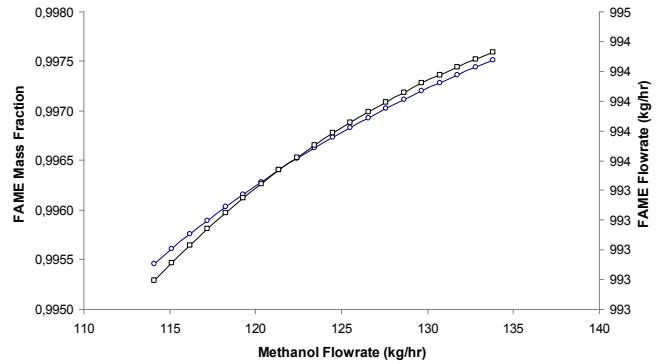

Figure 10 Sensitivity Analysis Methanol Flow vs. FAME Flow rate.

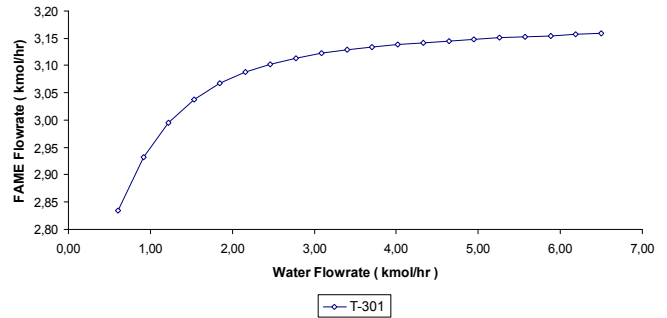

Figure 11 Sensitivity Analysis Water Flow vs. FAME Flow rate.

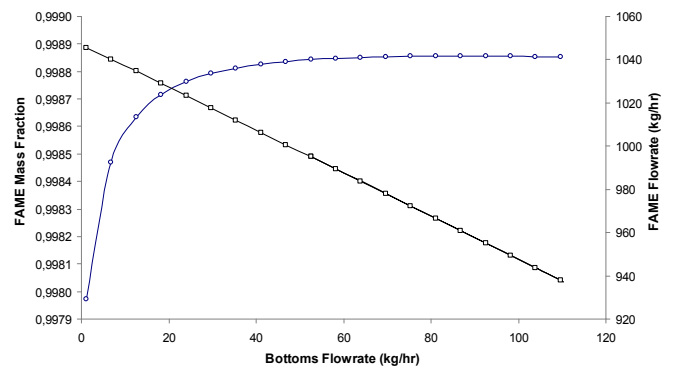

Figure 12 Sensitivity Analysis Tower T-401 Bottoms Flow rate vs. FAME Flow rate.

Comparatively, this article presents an increase in FAME production over the rigorous calculation of 24%,

while it enhanced the short calculation by 10% and Zhang et. al. (2003) publication by 5%.

For this case of study a very specific analysis was effectuated for methanol and bottoms flow rate. Figure 10 illustrate that the optimum value for this variables has been achieved since changes on the methanol flow rate did not represent important variations on ether the FAME flow or FAME mass fraction. On the other hand, Figure 12 show that for variations on the bottoms flow there were important fluctuations on FAME flow rate without disturbing importantly the purity of the product.

## 6.2 Costs

A design has to represent a profitable plant. Initially, enough capital has to be available for construction and its adequacy, as a key aspect of the industrial unit.

Estimates on equipment cost and other related capital investment costs, play a crucial roll on the selection of design alternatives [25].

Costs Analysis for the Biodiesel Production Process		
Main Process Units	Parameters	
Transesterification (Reactor CSTR)	Volume, m3	4,86
	Material	Carbon Steel
	Cost, US\$	\$ 1.200.000
Recovery <i>Methanol</i> (Distillation Column)	Diameter, m	0,32
	Material	Carbon Steel
	Height, m	6
Washing column (Extraction Column L-L)	Cost, US\$	\$ 64.800
	Height, m	4,8
	Diameter, m	1,1
	Adjusting Factor (Pressure)	1,6
	Adjusting Factor (Material)	1,0
Purification <i>FAME</i> (Distillation Column)	Cost, US\$	\$ 24.000
	Diameter, m	0,9
	Material	Carbon Steel
	Height, m	4,8
<i>Glycerol</i> (Distillation Column)	Cost, US\$	\$ 19.200
	Diameter, m	0,47
	Material	Carbon Steel
Heat Exchangers	Height, m	4,8
	Cost, US\$	\$ 12.000
		\$ 4.000
Pumps		\$ 45.000
Other Costs (Separator, Vacuum System)		\$ 46.000
Total Basic Module Cost, $C_{MBO}$		\$ 1.415.000
Total Bare Module Cost, $C_{MB}$		\$ 1.768.750
Contingency Fee, $C_c = 0.18C_{MB}$		\$ 318.375
Total Module Cost, $C_{TM} = C_{MB} + C_c$		\$ 2.087.125
Auxiliary Facility Cost, $C_A = 0.3C_{MB}$		\$ 530.625
Fixed Capital Cost, $C_{FC} = C_{TM} + C_A$		\$ 2.617.750
Working Capital, $C_T = 0.15C_{FC}$		\$ 392.663
Total Capital Investment, $C_{TC} = C_{FC} + C_T$		\$ 3.550.498

Table 1 Costs Analysis for the Biodiesel Production Process.

The costs in Table 1 are listed in United States dollars. Costs for the equipment were updated through the Marshall & Swift cost index obtained in the Chemical Engi-

neer magazine, where  $I_{2002} = 1,104.2$  y  $I_{2006} = 1,302.3$  [27].

Turton et. al. (1998) mentioned that this type of estimate was a + 30% and -20% precision. Thus, the results don't reflect a strict capital cost analysis; instead they are a very useful comparative parameter.

## 7 Results Analysis

Two important characteristics were identified while comparisons were made between the results obtained for the short calculation and the base case simulation: the reproductive and repetitive character of the exercise. The reproductive character is associated with the fact that the simulation could be replicated and the repetitive factor is supported on the 82% concordance found among the Zhang et. al. (2003) article's results and this case of study outcome. This discrepancy could be related with the differences in the thermodynamical parameters stored within each one of the software used for the particular papers.

A detailed analysis on Table 2 reveals the potential for improvement that has the technical evaluation developed by Zhang. et. al. (2003) confronted with this case of study. Consequently, a 3.8% increase on the reactor conversion has been related mainly with a 20 °C modification effectuated within the base case, on the reactors temperature. Moreover, the methyl ester fraction increased in 5 wt% as a response on the 6 times increment experienced by the solvent on the liquid – liquid extraction tower.

A closer approach of this important table exposes two of the most important concepts related to optimization: local and global optimum. A local optimum has an objective value that is better than the one of any nearby feasible solution, while global optimum is a feasible solution that has the best objective value. Since fluctuations on the variables analyzed did not implicate considerable changes, on the optimum biodiesel production found this value can be categorized as a global optimum.

Comparative Analysis for the Biodiesel Production Process			
Parameters	Zhang. et al.	Velosa. et. al. P I	Velosa. et. al. P II
Reaction Temperature, C	60	80	80
Reactor Yield	95,0%	99,8%	99,8%
Methanol Purity, wt%	1,000	1,000	1,000
Water Flow, kg/h	11	66	66
FAME Extraction, wt%	0,946	0,994	0,993
Glycerin Purity, wt%	0,850	0,994	0,995
FAME Purity, wt%	0,997	0,998	0,998
FAME Production, kg/h	999,88	1048,06	1047,54
Cost, US\$	\$ 3.144.010	\$ 3.550.498	\$ 3.550.498

Table 2 Comparative Analysis for Different Biodiesel Production Processes.

The reactor as the plant's hearth and one of the most important units of this complicated process should have a detailed analysis. The operative pressure and temperature range has to be established by means of a kinetic analysis as well as the physical characteristics of the reactants. The temperature range was determined through the graphical analysis of Figure 16, which illustrates the  $\ln(k)$  variation against  $1/T$ . As the production of diglyceride increases and the temperature augments the line that represents the diglyceride to monoglyceride reaction is located above the line which represents the diglyceride to triglyceride reaction, obtaining enough monoglyceride in order to produce methyl oleate (methyl ester). Furthermore, the pressure range was determined as to avoid methanol evaporation at the established temperature. At 400 kPa methanol's boiling point is 104.7 °C.

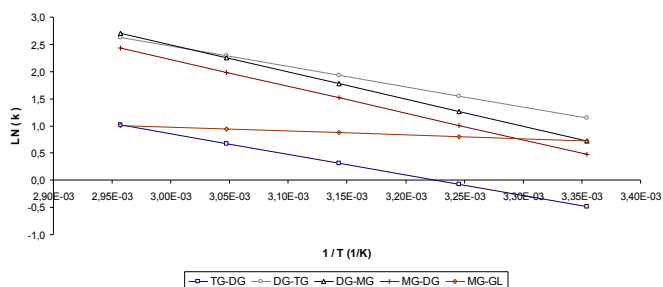

Figure 13 Kinetic Analysis of the Transesterification Reaction.

The optimization of biodiesel production and the glycerin purity, finding the operation and design conditions that made the process a competitive one is the most important contribution of this article. In this case of study glycerin surmounts the expectations since it presented a 17% increase compared with the base case. However, Zhang et. al. (2003) has reported that up to a 92 wt% purity is possible by means of a distillation column; this type of variation can be related to the thermodynamical model, as well as the prevailing discrepancies among the simulation software. Moreover, biodiesel production increased significantly 5% compared with the base case.

At the optimum point, variables as the water flow and the distillate flow in FAME's purification column have an important impact over biodiesel production, in other words fluctuations around this variables implicate significant changes on the objective function.

An important variable affecting the conversion of ester is the alcohol to triglyceride molar ratio; higher molar ratios result in greater ester conversion in a shorter time. For this particular work the optimum molar ratio was established at 7:1.

One of the most important process operations is the liquid – liquid extraction column, because it allows the separation of methanol, glycerol (as a secondary product) and the main product. At this unit, the water flow has a significant influence on the process which is directly re-

lated with the column exit methyl ester fraction. A close insight on this last paragraph shows that it is necessary to use 66 kg/h of water in order to obtain a 99.3 wt% purity of FAME, presenting an asymptotic tendency at a value of 3.13, in other words an increase on the amount of water added would not represent an important increase on the purity of the main product.

A detailed analysis on the distillation columns permits an evaluation of the most important variables established by Zhang et. al. (2003). On this type of industries profitability could be allocated to on the ability to encounter new sources of revenue; this is the case of glycerol and mainly its purity.

FAME and glycerol are susceptible to the thermal decomposition above 250 and 150 °C, respectively [10]. Glycerin purity could not be above a value of 95.3 wt% with a unique separation unit at a pressure of 40 kPa, since the temperature obtained at the bottom of the tower would be 149 °C, value that represents an imminent denaturalization risk. Nonetheless, if the pressure is decreased to 5 kPa the main product purity reaches a value of 99.4 wt%, with a bottoms temperature of 143.4 °C.

The biodiesel purification tower defines the products' quality through the distillate flow. As the relation of those two variables is direct, an increment on the distillate flow would permit an increase on the biodiesel purity until the quality and design constrains are reached; this procedure would structure the global optimum finding. In this particular case, adding the distillate flow as a variable to be optimized represented a 13% increase on FAME production comparatively.

The economical evaluation has been a great complement to the simulation and optimization processes, since it reduces the limitations between the academic exercise and reality and permit's a starting point for the election of the variables to be optimized from a financial and not only a technical, point of view.

Zhang et. al. (2003) determined the cost of a biodiesel production plant with the same characteristics described by this article, obtaining an estimated investment of US\$ 3,144,010. On that article the biodiesel production was established at 8,000 tons/year, the reactor conversion was set at 95% and the glycerin purification costs were not included. However, the total cost of this research production mill was US\$ 3,550,498, with a 99.8% reactor conversion, as well as a glycerin purity of 99.4 wt%. In terms of production, this 5% increment will represent approximately a 330.322 US\$/year profit (biodiesel prices obtained from Zhang et. al. (2003) and Castañeda et. al (2006)).

The cost difference for the two plants is based principally on the reactor volume increase, in order to have a 99.8% conversion, in addition to the material augmentation that this change represents. It is important to mention

that this conversion value is very similar to the one presented by companies as Lurgi [30].

As the technical aspect evolves in order to find the optimal production conditions before the start up of the production plants, the National Government and the private industry develop projects that facilitate the conditions necessary to meet the politics of the laws.

The National Government projections for the following years include plantations of one million African palm hectares, focused on the biodiesel production for national consumption as well as its exportation, producing approximately 150,000 barrels/day; this scheme will generate an estimate of one million direct jobs, and an important alternative for the illicit crops substitution.

The legislature has joint efforts as a strategic ally providing an important set of advantages. These advantages go from tax reduction (Law 939/04), to duty free territories (Decreto 383/07), as to promote investors to support this type of industry. In addition, based on the region characteristics the Interamerican Development Bank (IDB) will finance biofuels production projects in Latin America.

Biofuels are one of the most important economical and energetic alternatives that Colombia has experimented since the Cusiana and Cupiagua discovery. It is time to use the condition of an agricultural country, in order to establish independence on non renewable combustion sources, playing a main roll on the technological development and implement actions that allow an increase in FAME production efficiency.

## 8 Conclusions

The continuous biodiesel production process using palm oil, as raw material, by means of homogenous catalysis was simulated obtaining satisfactory 8,400 tons/year production. The bibliographic review allowed the definition of the thermodynamical models and kinetic models necessary to accomplish conditions as real as possible. The optimization part of this study incremented the production in 5% compared with the base case published by Zhang et. al (2003).

To develop an academic analysis, the simulation tool chosen for the production mill modeling was Aspen Plus®, demonstrating among all its benefits the replicability and reproducibility character, establishing the bases in order to be able to compare the results obtained with the ones described by the base case.

The use of three different thermodynamical activity models as: NRTL, UNIQUAC and UNIFAC-Dortmund have been shown to reduce the limitations between the academic exercise and reality, since it reflects the exper-

imental data and the complete immiscibility of the main compounds.

The relationship between the technical concepts and the economical factors is decisive when a project is evaluated, since those two perspectives are directly involved on its viability.

A projects economical evaluation is a great complement to a technical approach, since reduces the limitations between the academic exercise and reality and allows a starting point for the election of the variables to be optimized.

The variables that have a mayor effect on this case of study are the water flow and the distillate flow on the FAME purification unit. Consequently, the variation and inclusion of this parameters on the software incremented the base case production by 5% and 24% compared to the rigorous calculation; these values represent a utility increase of 330.322 U\$/year, taking into account that the methyl ester prices were calculated as to meet the equilibrium point (zero utility).

The reactor conditions were fixed at 80 °C and 400 kPa, since those are the most adequate for the plants correct performance.

Interestingly, the glycerin purity can not be set over 99.4 wt% purity without having a thermal denaturalization possibility if the columns pressure is 5 kPa.

The biodiesel production cost for this study is U\$ 3.550.498, with a 99.8% reactor conversion, a 99.8 wt% FAME purity and a 99.4 wt% glycerin purity.

## Nomenclature

- A* Methanol.
- T* Triglyceride.
- D* Diglyceride.
- M* Monoglyceride.
- G* Glycerol.
- E* Methyl Ester.
- R* Alcoholic radical.
- R'* Triglyceride radical.
- wt%* Weight percentage.
- K* Equilibrium constant.
- k<sub>1</sub>* Reaction constant triglyceride-diglyceride.
- k<sub>2</sub>* Reaction constant diglyceride-monoglyceride.
- k<sub>3</sub>* Reaction constant monoglyceride-glycerol.
- k<sub>4</sub>* Reaction constant diglyceride-triglyceride.
- k<sub>5</sub>* Reaction constant monoglyceride-diglyceride.
- k<sub>6</sub>* Reaction constant glycerol-monoglyceride.
- λ* Lagrange multipliers.

## Acknowledgements

The author acknowledges the collaboration of companies as Cenipalma, Fedepalma and Cemex. The Los

Andes University professors Dr. Jorge Mario Gomez, Ing. Ruben Fajardo and Ing. Ivan Gil. Furthermore, his family, Natalia Olarte and friends.

## 9 References

- [1] Knothe. G.; Krahl. J; Gerper. J. The Biodiesel Handbook., 2004. AOCS Press, Champaign, Illinois. (Chapters 1 and 2).
- [2] Ma. F.; Hanna. M. Biodiesel production a review. *Bioresource Technology* 70. 1999.
- [3] Lee, D. H.; Lee, D. J. Biofuel economy and hydrogen competition. *Energy & Fuels* 22. 2008.
- [4] Cunha, R. Potencial for producing bio-fuel in the Amazon deforested areas. *Biomass and Bioenergy* 26. 2004.
- [5] Piedraita. C. Boletín Estadístico de Minas y Energía. Ministerio de Minas y Energía. Unidad de Planificación Minero Energético 2006. *Recovered September 25<sup>th</sup> form the web page: <http://www.upme.gov.co/Index2.htm>.*
- [6] Rincón. S.; Cuellar. M.; Cadena. A. Estudio Prospectivo para el Desarrollo de la Oleoquímica del Aceite de Palma en Colombia (Cenipalma 2002).
- [7] Federación Nacional de Cultivadores de Palma de Aceite (Fedepalma). Balance Económico. Unidad de Economía y Comercio de Fedepalma. March 2007.
- [8] Zhang, Y., 2003. Design and economic assessment of Biodiesel production from waste cooking oil. Part 2. M.A.Sc. thesis, Department of Chemical Engineering, University of Ottawa.
- [9] Zhang, Y., 2003. Design and economic assessment of Biodiesel production from waste cooking oil. Part 1. M.A.Sc. thesis, Department of Chemical Engineering, University of Ottawa.
- [10] Velosa, F.; Gomez, J. M. Simulation and Optimization of the process used in Colombia for the production of Biodiesel from palm oil. July 2007.
- [11] You, Y. D. Economic cost analysis of biodiesel production: case in soybean oil. *Energy and Fuels* 22. 2008.
- [12] West, A. H. Assessment of four biodiesel production process using HYSYS.Plant. *Bioresource Technology*, 2008.
- [13] Freedman, B.; Pryde, E. H.; Mounts, T. L. Variables affecting the yields of fatty esters from transesterified vegetable oils. *J. Am. Oil Chem. Soc.* 1984, 61 (10), 1638.
- [14] Vicente, G.; Martinez, M.; Aracil, J.; Esteban, A.; Kinetics of sunflower oil methanolysis. *Ind. Eng. Chem. Res.* 2005, 44, pages 5447-5454.
- [15] Nouredini. H.; Zhu.D. Kinetics of transesterification of Soybean Oil. *JAOCS*, V. 74, No 11, 1997, pages 1457 – 1463.
- [16] Darnoko, D.; Cheryan, M. Kinetics of palm oil transesterification in a batch reactor. *J. Am. Oil Chem. Soc.* 2000, 77 (12), 1263.
- [17] Jordan. V.; Gutsche. B. Development of an environmentally benign process for the production of fatty acid methyl esters. *Chemosphere* 43, 2001, pages 99 – 105.
- [18] Germen. J. A Workshop for the 2005 Biodiesel Conference and Expo. *Biodiesel Production Technology*. February, 2005.
- [19] Seider, W.; Seader, J.D.; Lewin, D. Product and process design principles. Wiley. 2004. Second Edition.
- [20] Antolin. G.; Tinaut, F.; Briceno. Y.; Castano. V.; Perez, C.; Ramirez, A. Optimization of Biodiesel production by sunflower oil transesterification. *Bioresource Technology* 83. 2002.
- [21] Negi. S.; Sobotka. F.; Kimmel. T.; Wozny. G.; Schomacker. R. Liquid – Liquid Phase Equilibrium in Glycerol – Methanol – Methyl Oleate and Glycerol – Monoolein – Methyl Oleate Ternary Systems. *Ind. Eng. Chem. Res*, 2006, 45. Pages 3693 – 3696.
- [22] Carlson. E. Don't Gamble With Physical Properties For Simulations. Aspen Technology. Inc. 1996. *Chemical Engineering Progress*.
- [23] Reid. R.; Prausnitz. M.; Poling. E. The Properties of Gases & Liquids. McGraw Hill, 1988. Fourth Edition.
- [24] Himmelblau. D.; Edgar. T. Optimization of Chemical Processes. McGraw Hill, 2001. Second Edition.

[25] Peters. M.; Timmerhaus. K.; West. R. Plant Design and Economics for Chemical Engineers. McGraw Hill, 2001. Fifth Edition.

[26] Turton, R., Bailie, R.C., Whiting, W.B., Shaeiwitz, J.A., 1998. Analysis, Synthesis, and Design of Chemical Processes. Prentice Hall PTR, New Jersey.

[27] Chemical Engineering. Industrial Electrochemistry: A Look at the Plus Side. May 2007. Volume 114, Issue 5.

[28] R. Perry.; D. Green.; Maloney. Manual del Ingeniero Químico, 2001. Volume 1. McGraw Hill. Seventh Edition.

[29] Castañeda. Z.; Narváez. P.; Rincón. S.; Sánchez. F. Simulación de un Proceso para la Producción de Esteres Metílicos de Aceite de Palma.

[30] Confidential Document. Cenipalma. Reviewed June 2007.